

SMMSi/ SHRMi VRF Controls and Accessories BMS-SM1280HTLUL - Smart Manager

TOSHIBA
Carrier

Submittal Data

Job Data _____ Location _____
 Buyer _____ Buyer PO # _____ Carrier # _____
 Unit Number _____ Model Number _____
 Performance Data Certified By _____ Date _____



MAX 128 INDOOR UNITS PER SMART MANAGER
(2 TCC links with 64 units each)

SMMSi/ SHRMi VRF Smart Manager Features

- Displays all units on one screen
- Shows basic indoor unit setting on main screen
- Advance operation and master schedule functions are available
- Up to 4 concurrent web browser users can be connected simultaneously
- Up to 32 users accounts can be programmed with different levels of access (at least one must be administrator level)
- Energy monitoring and report creation functions are available
- Advance operation and master schedules can be set on a calendar
- Additional digital I/O device available
- Thin profile controller and separate power supply unit enables easy installation
- Up to 10 scheduled events / day, 32 separate schedule patterns / year

PART NAME		SMART MANAGER	POWER UNIT
Model Number		BMS-SM1280HTLUL	
Power Supply		Use bundled power unit	120 VAC, 60 Hz
Power Consumption			6 W (SM1280) / 4 W (CM1281)
Connectable unit number	Indoor Unit	Up to 128 units Line 1: Up to 64 units Line 2: Up to 64 units	—
	Energy monitoring interface	Up to 4 units	—
	Digital input / output interface	Up to 4 units	—
Operating temperature / humidity		32 to 104 F (0 to 40 C), 10 to 90% RH (no condensation)	
Dimension		4.72 (H) x 7.09 (W) x 2.52 (D) in. (120 (H) x 180 (W) x 64 (D) mm)	4.49 (H) x 6.97 (W) x 1.97 (D) in. (114 (H) x 177 (W) x 50 (D) mm)
Weight lb (kg)		1.77 (0.8)	1.99 (0.9)

Manufacturer reserves the right to discontinue, or change at any time, specifications or designs without notice and without incurring obligations.

DIMENSIONAL DRAWING SMART MANAGER BMS-SM1280HTLUL

CENTRAL CONTROLLER

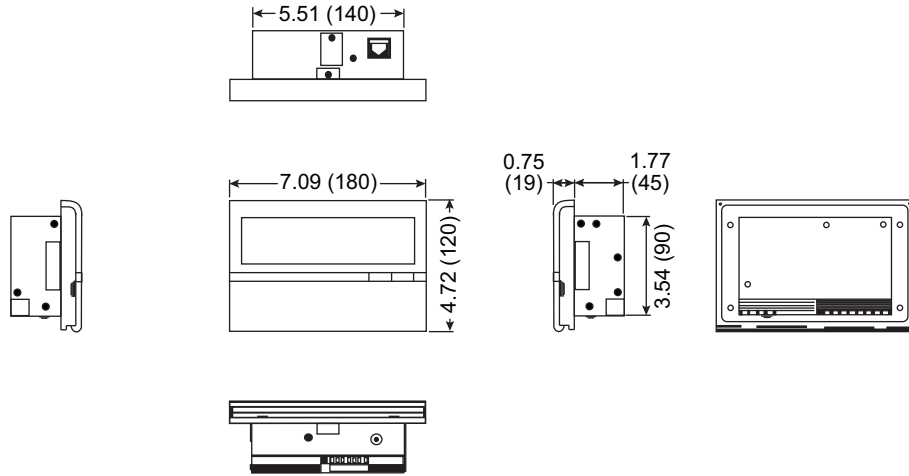

POWER UNIT

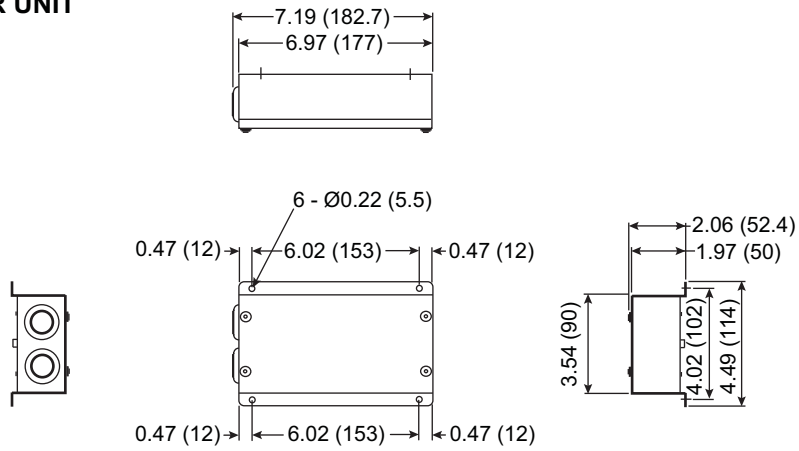

NOTE: Dimensions are in inches (mm).