

Installation Instruction

NOTE: Read the entire instruction manual before starting the installation.

SAFETY CONSIDERATIONS

Improper installation, adjustment, alteration, service, maintenance, or use can cause explosion, fire, electrical shock, or other conditions which may cause death, personal injury, or property damage. Consult a qualified installer, service agency, or your distributor or branch for information or assistance. The qualified installer or agency must use factory-authorized kits or accessories when modifying this product. Refer to the individual instructions packaged with the kits or accessories when installing.

Follow all safety codes. Wear safety glasses, protective clothing, and work gloves. Have a fire extinguisher available. Read these instructions thoroughly and follow all warnings or cautions included in literature and attached to the unit. Consult local building codes, the current editions of the National Fuel Gas Code (NFGC) NFPA 54/ANSI Z223.1 and the National Electrical Code (NEC) NFPA 70.

In Canada, refer to the current editions of the National Standards of Canada CAN/CSA-B149.1 and .2 Natural Gas and Propane Installation Codes, and Canadian Electrical Code CSA C22.1.

Recognize safety information. This is the safety-alert symbol . When you see this symbol on the unit and in instructions or manuals, be alert to the potential for personal injury.

Understand the signal words **DANGER**, **WARNING**, and **CAUTION**. These words are used with the safety-alert symbol. **DANGER** identifies the most serious hazards which **will** result in severe personal injury or death. **WARNING** signifies hazards which **could** result in personal injury or death. **CAUTION** is used to identify unsafe practices which **may** result in minor personal injury or product and property damage. **NOTE** is used to highlight suggestions which **will** result in enhanced installation, reliability, or operation.

 **WARNING**

FIRE, EXPLOSION, ELECTRICAL SHOCK HAZARD

Failure to follow this warning could result in personal injury, death and/or property damage.

The ability to properly perform maintenance on this equipment requires certain knowledge, mechanical skills, tools, and equipment. If you do not possess these, do not attempt to perform any maintenance on this equipment other than those procedures recommended in the Owner's Manual.

 **WARNING**

FIRE, EXPLOSION, ELECTRICAL SHOCK AND CARBON MONOXIDE POISONING HAZARD

Failure to follow this warning could result in personal injury, death and/or property damage.

Improper installation, adjustment, alteration, service, maintenance, or use can cause carbon monoxide poisoning, explosion, fire, electrical shock, other conditions, which could result in personal injury or death. Consult your distributor or branch for information or assistance. The qualified installer or agency must use only factory-authorized kits or accessories when servicing this product.

 **WARNING**

ELECTRICAL SHOCK, FIRE OR EXPLOSION HAZARD

Failure to follow this warning could result in personal injury or death, or property damage.

Before installing, modifying, or servicing system, main electrical disconnect switch must be in the OFF position and install a lockout tag. There may be more than one disconnect switch. Lock out and tag switch with a suitable warning label. Verify proper operation after servicing.

INTRODUCTION

This instruction covers the installation of Internal Vent Kit for 90+% efficient condensing gas furnaces. This kit allows the combustion air and the flue vent to be routed through the blower compartment instead of outside the furnace. In order to install this kit, four holes will need to be added to the furnace. Two holes will be in the bottom plate, and the other two will be in the blower shelf. Seals will then need to be placed at these holes to ensure that the blower compartment is still sealed.

DESCRIPTION AND USAGE

Use this kit in order to install combustion air and vent pipe through the furnace blower compartment. See Table 1 for a list of all the parts in this kit. To install this kit, the items listed in Table 2 will be needed from the loose parts bag that is provided with the furnace:

Table 1 – Kit Contents

QUANTITY	DESCRIPTION
1	ELBOW, VENT
2	SEAL, AIR
2	CLAMP
1	COUPLING ASSY
1	COUPLING
2	CLAMP, HOSE
12	SCREW
1	SHEET
1	SHIELD, RAIN

Table 2 – Parts Necessary from Loose Parts Bag

QUANTITY	DESCRIPTION
1	COUPLING
1	COUPLING, VENT
2	GASKET, AIR
2	CLAMP, HOSE
4	SCREW

INSTALLATION

⚠ WARNING

CARBON MONOXIDE POISONING HAZARD

Failure to follow this warning could result in personal injury, death and/or property damage.

Failure to properly seal the blower compartment from furnace vestibule could result in carbon monoxide to be circulated through the structure. Vent and combustion air pipes must be a continuous pipe while passing through the blower compartment. Seals supplied in this kit must be installed per the instructions provided.

⚠ CAUTION

FURNACE RELIABILITY HAZARD

Failure to follow this caution may result in unit component damage.

Failure to properly shield the inducer motor and control from metal shavings produced while installing this kit may cause damage to those parts. Shield must completely cover the entire inducer assembly at all times while drilling or punching holes in the furnace.

⚠ CAUTION

FURNACE RELIABILITY HAZARD

Failure to follow this caution may result in unit component damage.

Do not use a hole saw to place the holes in the blower shelf or the bottom plate. For the 3/4-in. (19 mm) hole, a knockout punch or step drill may be used. For the 2 1/2-in. (63.5mm) hole, use a knockout punch.

Drilling Preparation

1. Gather the coupling, vent coupling, worm gear hose clamps, gasket and screws from the loose parts bag. The part numbers and quantities are listed in the table above.
2. Invert the furnace.
3. Remove the blower assembly from the furnace.
4. Cover the inducer motor and inducer control (if applicable) with the provided paper cover and secure it to the blower shelf. Proper installation of the cover is shown in Fig. 3 and 4.

Drill Holes into Bottom Plate and Blower Shelf

1. Drill two 3/4-in. (19 mm) holes in the bottom plate by using the dimples to locate the centers.

NOTE: Do not drill a hole using the dimple that is located 1 3/8-in. (35mm) from the side of the furnace. Fig. 1 shows which dimples to use.

2. Use a knockout punch to place two 2.5-in. (63.5mm) holes in the bottom plate using the 3/4-in. (19 mm) holes.

NOTE: Use either Greenlee® knockout part number 35182 or part number 730BB 2-1/2 to make these holes. See Fig. 2 for an example of the required punch.

3. Drill two 3/4-in. (19 mm) holes in the blower shelf by using the dimples to locate the centers.
4. Use a knockout punch to place two 2.5-in. (63.5mm) holes in the blower shelf using the 3/4-in. (19 mm) holes.
5. Replace the production inducer elbow with the elbow supplied in the kit, and orient the outlet towards the blower compartment. Remove the clamps on the production elbow and use them with the elbow supplied in the kit. Discard the production inducer elbow.
6. Construct the blower shelf seal assemblies by placing a clamp and a worm gear hose clamp on each of the blower shelf seals as shown in Fig. 8.
7. Place the blower shelf seal assemblies in the blower compartment, resting the assemblies on the blower shelf with the flat section of the seal facing the blower shelf flange as shown in Fig. 8.
8. Pilot drill 1/8-in. (3.2 mm) screw holes into the dimples in the blower shelf.
9. If installing this kit into a 14 or 17 inch wide furnace, a rain shield is required. Attach the rain shield to the blower shelf seal assembly for the combustion air pipe. Alignment of the rain shield is shown in Fig. 6 And 7.
10. Insert a length of 2-in. (50.8 mm) PVC pipe through the casing into the outlet of the vent elbow.
11. Slide the plastic vent pipe adapter over the length of the vent pipe down to the furnace casing. Mark the pipe where it is flush with the outlet of the adapter.
12. Pilot drill 1/8-in. (3.2 mm) screw holes for the adapter in the bottom plate.
13. Remove the pipe from the furnace and the adapter and cut off any excess pipe.
14. Insert a length of 2-in. (50.8 mm) PVC pipe through the casing inserted 1-in. (25.4) into the furnace vestibule.
15. Slide the plastic combustion air pipe adapter over the length of the combustion air pipe down to the furnace casing. Mark the pipe where it is flush with the outlet of the adapter.
16. Pilot drill 1/8-in. (3.2 mm) screw holes for the adapter in the bottom plate.
17. Remove the pipe from the furnace and the adapter and cut off any excess pipe.

Clean Furnace and Move Capacitor

1. Clean out any sheet metal shavings from the furnace.
2. Replace the blower assembly in the furnace, and remove the paper cover over the inducer.
3. If furnace has a capacitor mounted to the inducer housing and the capacitor is directly below the termination of the combustion air pipe, relocate the capacitor to center of the inducer housing. This location shown in Fig. 3.

Install Combustion Air and Vent Pipes

1. Clean and prime the end of the pipes that are flush with the vent adapters with a primer that is appropriate for the type of pipe being used.

2. Re-insert the vent pipe through the casing into the vent elbow.
3. Tighten the clamp around the outlet of the vent elbow and the clamp on the blower shelf seal assembly. Torque the clamps to 15 lb-in (1.7Nm). See Fig. 5.
4. Apply the gasket from the loose parts bag to the bottom of the vent adapter.
5. Apply cement to the end of the pipe and to the inside of the plastic vent adapter.

NOTE: The vent pipe must be cemented to the plastic vent pipe adapter to maintain a sealed vestibule.

6. Slide the adapter over the vent pipe and align the screw holes in the adapter with the pilot holes in the bottom plate.
7. Secure the adapter to the furnace with sheet metal screws.
8. Loosen the clamps on the rubber vent coupling.
9. Slide the end of the coupling with notches in it over the standoffs in the vent pipe adapter.
10. Tighten the clamp of the coupling over the vent pipe adapter. Torque the lower clamp around the vent pipe adapter to 15 lb-in (1.7Nm). Assembly is shown in Fig. 10.
11. Re-insert the combustion air pipe until it is 1-in. (25.4) into the furnace vestibule by going through the casing and blower shelf.
12. Tighten the clamp on the blower shelf seal assembly. Torque the clamp to 15 lb-in. (1.7Nm)
13. Apply the gasket from the loose parts bag to the bottom of the combustion air adapter.
14. Apply cement to the end of the pipe and to the inside of the plastic combustion air adapter.

NOTE: The combustion air pipe must be cemented to the plastic vent pipe adapter to maintain a sealed vestibule.

15. Slide the adapter over the combustion air pipe and align the screw holes in the adapter with the pilot holes in the bottom plate.
16. Secure the adapter to the furnace with sheet metal screws.
17. Loosen the clamps on the rubber vent coupling.

18. Slide the end of the coupling with notches in it over the standoffs in the vent pipe adapter.
19. Tighten the clamp of the coupling over the combustion air pipe adapter. Torque the lower clamp around the vent pipe adapter to 15 lb-in (1.7Nm). Assembly is shown in Fig. 10.
20. Finish installing the furnace per the furnace installation instructions that were supplied with the unit.



Fig. 1 - Greenlee® Knockout Punch

A11473

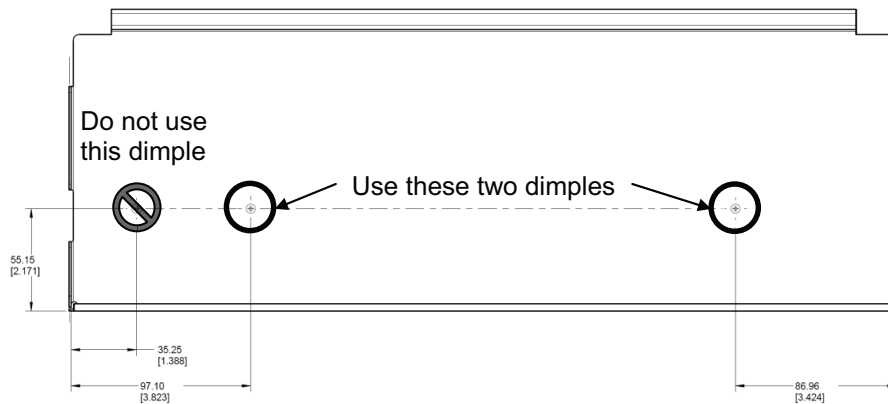

Fig. 2 - Bottom Plate Dimple Location

A11474

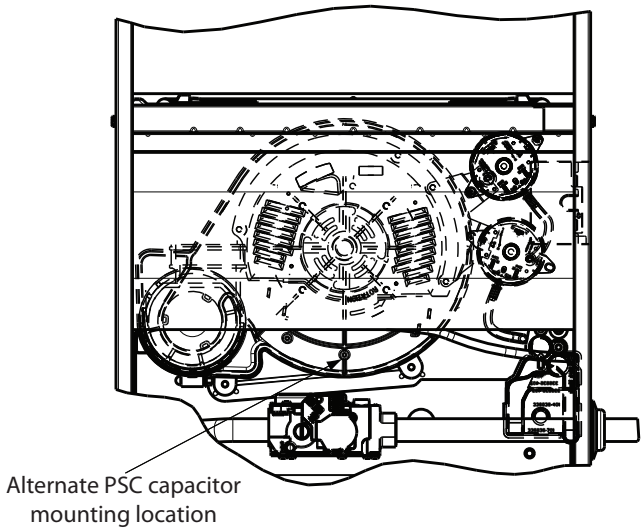

Fig. 3 - Inducer Shield Installation
(Actual Inducer will vary)

A11475

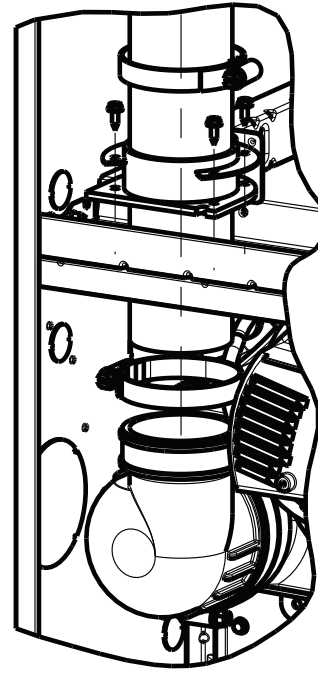

Fig. 5 - Inducer Elbow and Left Blower Shelf Seal

A11477

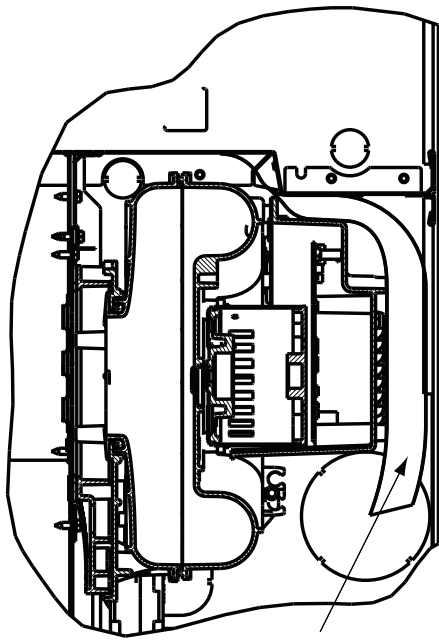

Fig. 4 - Inducer Shield Cross Section
(Actual Inducer will vary)

A11476

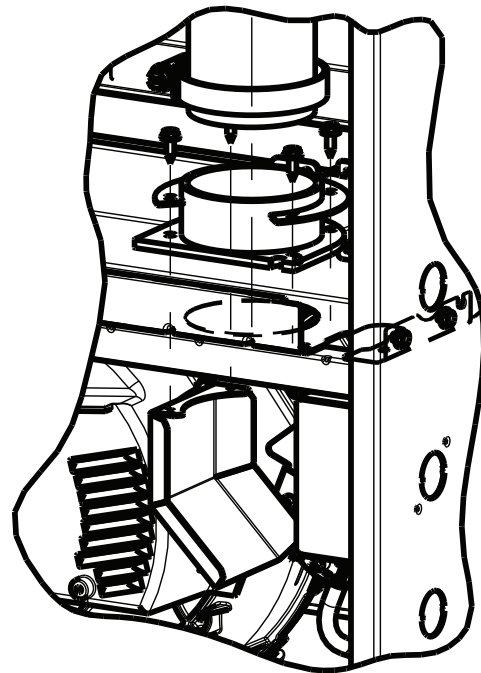

Fig. 6 - Rain Shield and Right Blower Shelf Seal Installation

A11478

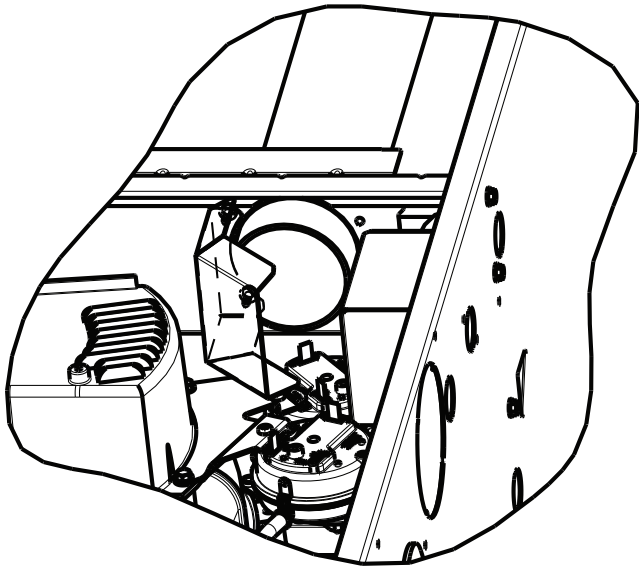

Fig. 7 - Rain Shield Installation

A11479

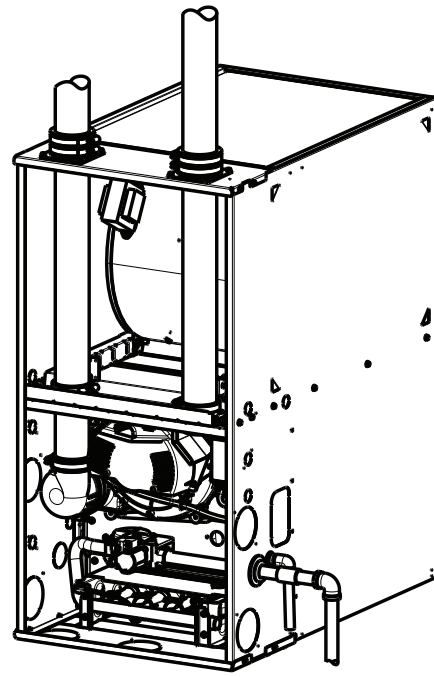

Fig. 9 - Assembled View of Internal Vent Kit

A11481

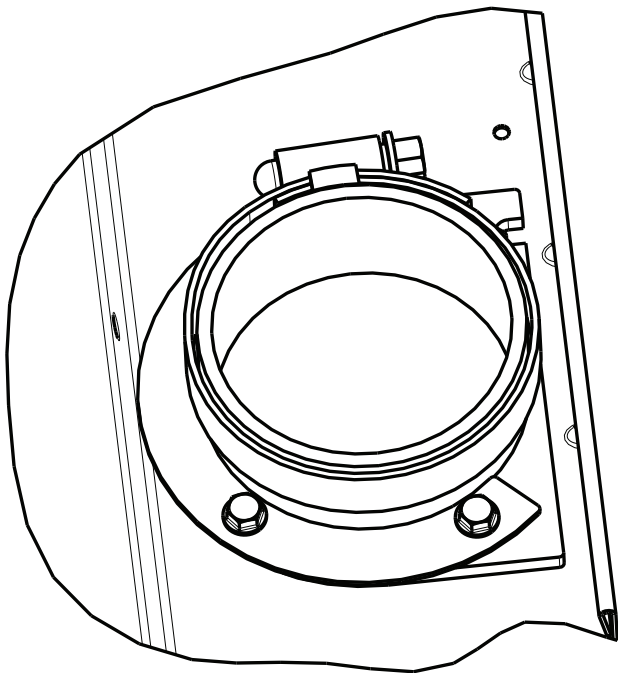

Fig. 8 - Blower Shelf Seal Assembly

A11480

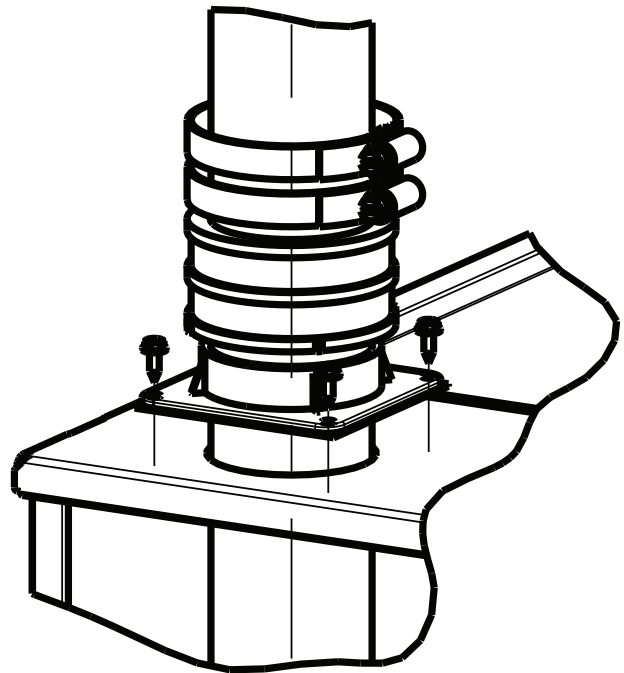

Fig. 10 - Vent Pipe Adapter Exploded View

A11482

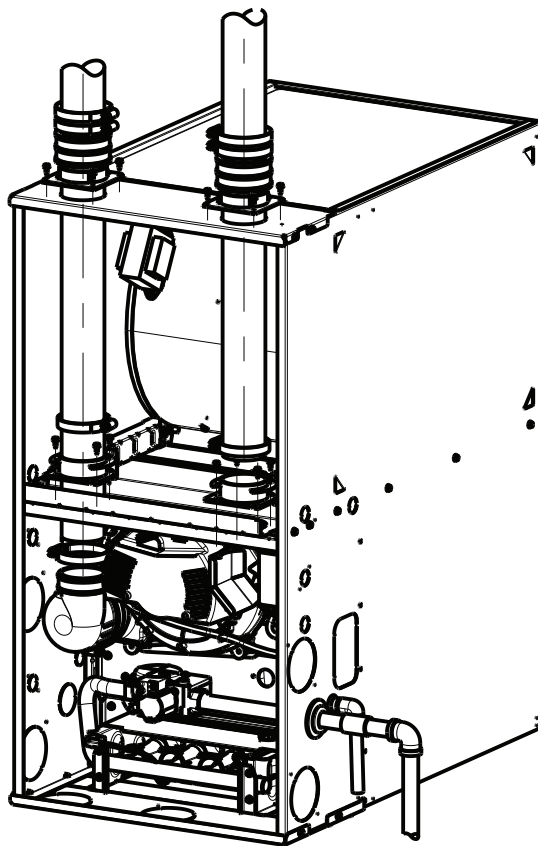

Fig. 11 - Exploded View of Internal Vent Kit

A11483