

Small Packaged Products Standard Altitude Only 0–2000 ft Accessory LP Conversion Kit

Cancels: IIK 582A-18-6

IIK 582A-18-7
1-01

Installation Instructions

60,000–130,000 Btu/hr

Part Number: CPLPCONV006A00 2 to 5 Tons


NOTE: Read the entire instruction manual before starting the installation.

This symbol → indicates a change since the last issue.

SAFETY CONSIDERATIONS

Installing and servicing air conditioning equipment can be hazardous due to system fuels. Only trained and qualified personnel should install, service, or repair air conditioning equipment.

Untrained personnel can perform basic maintenance functions such as cleaning coils, or cleaning and replacing filters. All other operations should be performed by trained service personnel. When working on air conditioning equipment, observe precautions in the literature, on tags, and on labels attached to the unit.

Recognize safety information. This is the safety-alert symbol . When you see this symbol on the unit and in instructions or manuals, be alert to the potential for personal injury.

Understand the signal words DANGER, WARNING, and CAUTION. These words are used with the safety-alert symbol. DANGER identifies the most serious hazards which **will** result in severe personal injury or death. WARNING signifies a hazard which **could** result in personal injury or death. CAUTION is used to identify unsafe practices which **would** result in minor personal injury or product and property damage. NOTE is used to highlight suggestions which **will** result in enhanced installation, reliability, or operation.

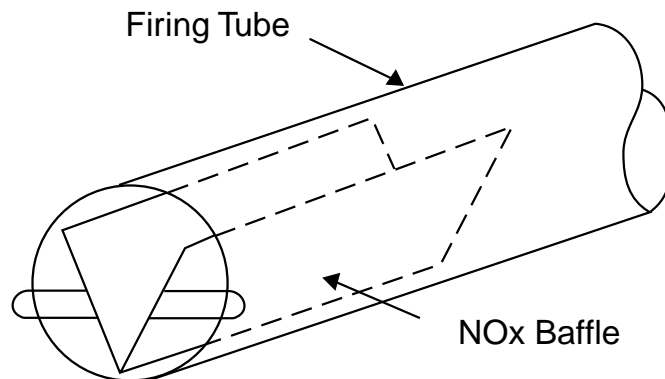
Follow all safety codes. Wear safety glasses and work gloves. Have a fire extinguisher available.

CAUTION

Before converting a unit to LP, remove the burner assembly and inspect the heat exchanger tubes. If there are V-shaped NOx baffles installed in the firing tubes (See Fig. 1). **THEY MUST BE REMOVED PRIOR TO CONVERTING THIS UNIT TO LP.** Discard the baffles after removal.

WARNING

This conversion kit is to be installed by qualified service personnel in accordance with these instructions and all codes and requirements of the authority having jurisdiction, and in Canada, in accordance with the requirements of the CAN/CGA (Canadian Gas Association) B149.2 Installation Code. Failure to follow these instructions could result in serious injury, property damage or death. The qualified agency performing this work assumes responsibility for this conversion.



C00151

→ Fig. 1—Low NOx Baffle Location

WARNING

This unit is designed to operate at 3.5 in. wg (± 0.3 in. wg) of manifold pressure with liquid propane (LP) gas. Exceeding this pressure may result in explosion, injury or death.

→ INTRODUCTION

These instructions cover the installation of a liquid propane conversion kit on models 48GS, 582A, PY1P-B, 48GX, 583A, PY2P-B, 48GP, and 583B that are equipped with a White Rodgers combination automatic gas valve regulator.

DESCRIPTION AND USAGE

This kit is applicable to units with heating inputs from 60,000 to 130,000 Btu/hr installed at standard altitudes from 0 ft to 2000 ft. *It cannot be used for high altitude installations or on units with heating inputs of 40,000 Btu/hr. High altitude conversions (2001–6000 ft) should use kit #CPLPCONV007A00. All conversions of 40,000 Btu/hr units should use Kit #CPLPCONV008A00 (applicable for any altitude from 0 ft to 6000 ft).*

INSTALLATION

WARNING

Before performing service or maintenance operations on unit, turn off gas supply first, then the main power switch to unit. Electrical shock could cause serious injury or death. TAG DISCONNECT SWITCH WITH SUITABLE WARNING LABEL.

-
1. Turn off gas supply first, then power to unit.
 2. Remove the front access panel from unit.
 3. Disconnect the gas pipe from the gas valve.
 4. Disconnect orange sparkler cable at the ignition control.

Manufacturer reserves the right to discontinue, or change at any time, specifications or designs without notice and without incurring obligations.

5. Disconnect yellow flame sensor wire from the ignition control.
6. Remove the screw securing the brown wire from the burner assembly and the green wire from the induced-draft motor at the sheet metal partition. Save screw.
7. Disconnect the gray and brown wires from the gas valve, and remove blue wires from the rollout switch.

12. Replace the manifold/gas valve assembly into the burner assembly using the four screws saved from Step 10.
13. Reconnect the blue wires to the rollout switch and reinstall rollout switch.
14. Reconnect the gray wire removed in Step 7 to terminal 1 (M1) of the gas valve. Reconnect the brown wire to terminal 2 (C2) on the main gas valve.
15. Reconnect orange sparkler cable and the yellow flame sensor wires at the ignition control.
16. Slide burner rack assembly into basepan. Align burner rack with screws on sheet metal partition and slide assembly back tight to the partition. Replace the screw attaching the burner rack to the basepan, removed in Step 8.
17. Reconnect the brown wire from the burner assembly and the green wire from the induced-draft motor to the sheet metal partition.
18. Remove the 1/8" pipe plug on the gas manifold and connect a pressure manometer.
19. Reconnect electrical power and gas supply to the unit.
20. Fire unit and verify proper ignition. Verify that the pressure manometer reads 3.5-in. \pm 0.3-in. wc. If the pressure is outside this range, adjust the gas valve setting by removing the slotted brass fitting and turning the nylon adjustment screw. Replace brass fitting.
21. Turn off unit, remove pressure manometer and replace the 1/8-in. pipe fitting on the gas manifold.
22. Attach warning label (P/N 48GS500615) to visible side of gas valve.
23. Attach conversion label (P/N 48GS500614) above unit rating plate on exterior of unit.
24. Attach completed conversion responsibility label (see Fig. 3, P/N 48SS500283) inside service access panel.
25. **IMPORTANT:** Restart unit and leak check all gas connections including the main service connection, gas valve, gas spuds, and manifold pipe plug.
26. After all leaks are eliminated, replace service panel.

→

Table 1—Kit Contents

ITEM	QUANTITY
LP Gas Orifice No. 41*	3
LP Gas Orifice No. 42*	3
LP Gas Orifice No. 46*	3
Warning Label	1
Conversion Label	1
Responsibility Label	1

* Refer to Table 2 to determine the correct orifice to use.

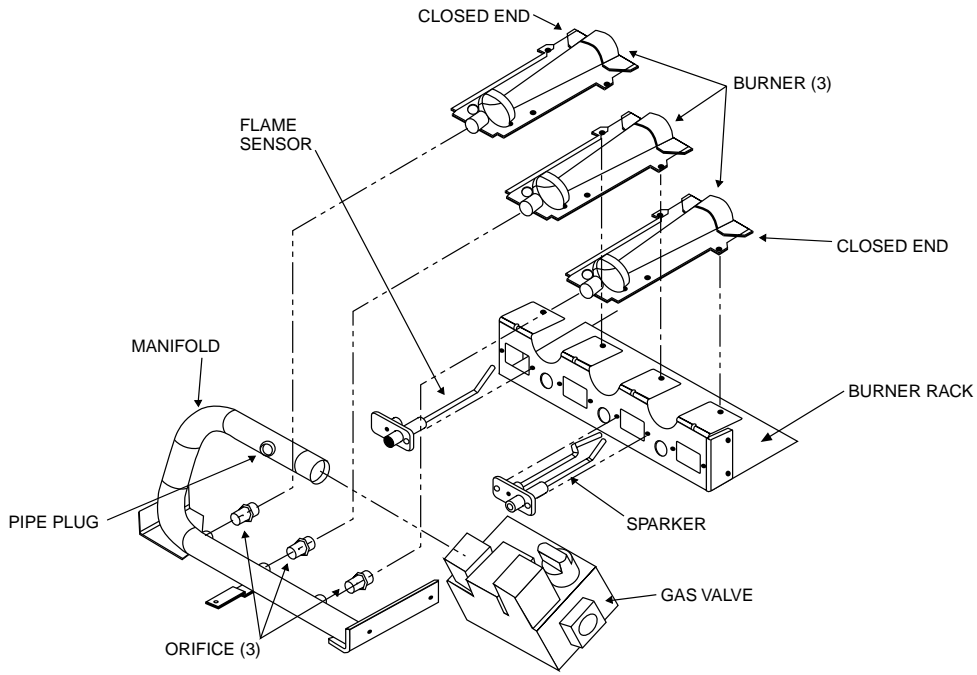
LP- Liquid Propane

- 8. Remove the screw attaching the gas manifold to the basepan, and slide out the entire burner rack assembly from unit. Save screw.
- 9. Inspect the inlet of the heat exchanger tubes for presence of V-shaped NOx baffles (see Fig. 1.) If baffles are present they **must be removed** prior to converting unit for LP gas. Slide the baffles out of the tubes (on some models a retaining clip must be released). **IMPORTANT: If it is expected that this unit will be converted back to natural gas at a later time, these baffles should be retained for reuse. Otherwise the baffles may be discarded.**
10. Using a 5/16 in. nut driver, remove the four screws securing the manifold/gas valve assembly to the burner assembly. **Save these screws.**
11. Remove the natural gas orifices from the manifold using a 9/16 in. wrench and install the correct LP gas orifices in the manifold (See Table 2 to select correct orifice size based on input. See Fig. 2 for orifice installation).

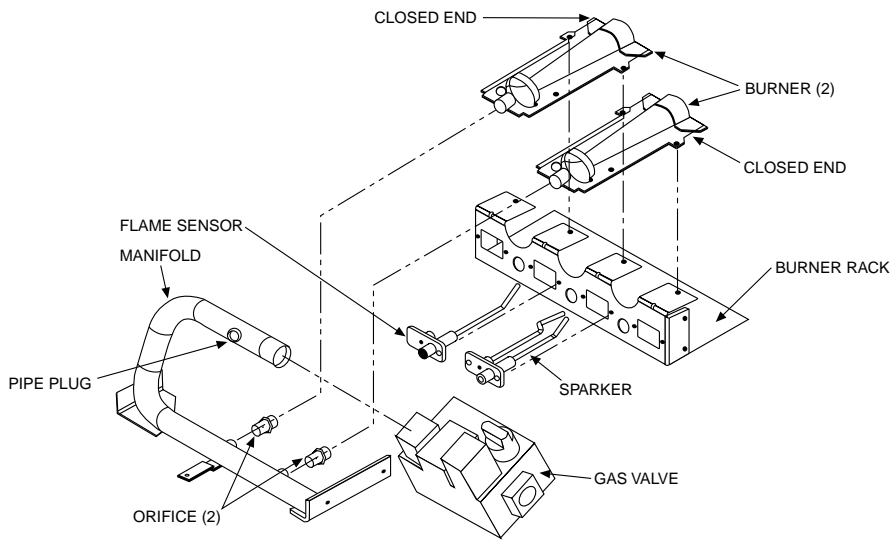


Table 2–LP Gas Orifice Sizes

UNIT SIZES	LP NOMINAL HEATING INPUT (BTUH)	NUMBER OF ORIFICES	GAS SUPPLY PRESSURE (IN W/C) (LP)		MANIFOLD PRESSURE (IN W/G) (LP)	LP GAS ORIFICE PART NO. AND SIZE ALTITUDE (FT)	
			MIN	MAX		0–2000	2001–6000
018040 024040 030040	40,000	THIS KIT APPLIES TO MODELS WITH HEATING INPUT OF 57,000 BTUH AND HIGHER. FOR 40,000 BTUH MODELS USE KIT # CPLPCONV008A00					
024060 030060 036060 042060	57,000	2	4.0	13.0	3.5	LH32RF080 No. 46	THIS KIT APPLIES TO STANDARD ALTITUDE INSTALLATIONS ONLY. ABOVE 2000 FT USE HIGH ALTITUDE LP CONVERSION KIT #CPLPCONV007A00
036090 042090 048090 060090	85,500	3	4.0	13.0	3.5	LH32RF080 No. 46	
048115 060115	115,000	3	4.0	13.0	3.5	LH32RF094 No. 42	
048130 060130	127,000	3	4.0	13.0	3.5	LH32RF096 No. 41	



85,500 BTUH TO 127,000 BTUH UNITS



57,000 BTUH UNITS

Fig. 2—Orifice Installation

C00149

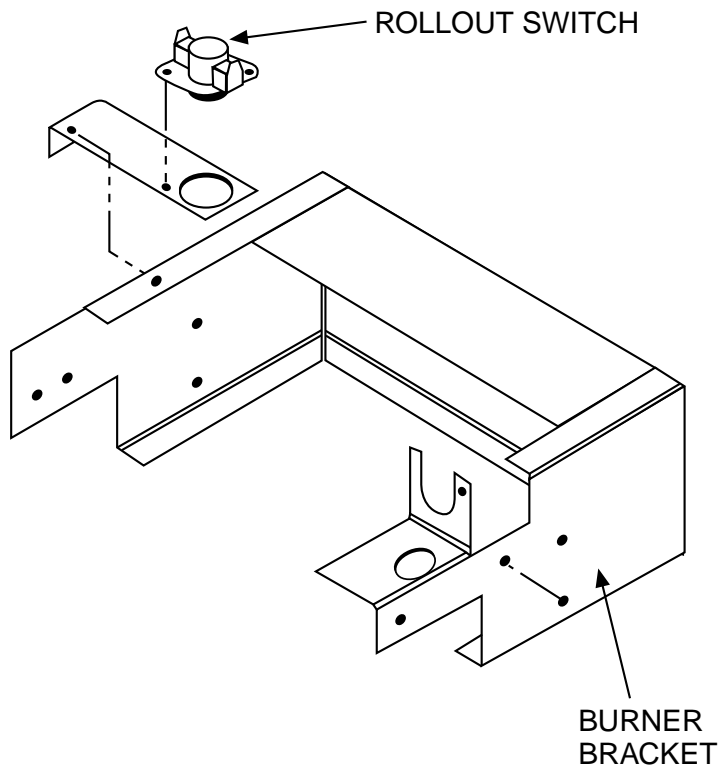


THIS APPLIANCE HAS BEEN CONVERTED
TO LP. GAS. KIT NO. _____
BY _____ DATE: _____
WHO ACCEPTS THE RESPONSIBILITY FOR
THE CORRECTNESS OF THIS CONVERSION.
48SS500283

A99309

→

Fig. 3—Conversion Responsibility Label



→

Fig. 4—Burner Bracket

C00150

Manufacturer reserves the right to discontinue, or change at any time, specifications or designs without notice and without incurring obligations.