

40,000-130,000 Btu/hr
Part Number:
CPLPCONV014C00

SMALL PACKAGED PRODUCTS
ACCESSORY PROPANE GAS CONVERSION KIT
HIGH ALTITUDE ONLY 2001-6000 FT (610-1829 m)

Installation Instructions

This kit is used on:

Two-Stage (2 - 5 Tons) Models: 48DU, 48DT, 48VG (208/230 VAC models), 48VR, 48XL, 48XT, 577B, 577D, 577E (208/230 VAC models), 677B, 677D and 677E. (Two-Stage conversion starts on Page 9.)

Single-Stage (1-1/2 - 5 Tons) Models: 48ES, (“1”) series or later (Examples: 48ES-060130311, 48ES-060130511, 48ES-060130611), 48ES-A, 48ESNA, 48EZ “1” series or later (Examples: 48EZ-060130311, 48EZ-060130511, 48EZ-060130611), 48EZ-A, 48EZNA, 48VG (460 VAC models), 48VL, 48VT, 574D “B” series or later (Examples: 574DNW060130NB, 574DPW060130NB, 574DEW060130NB), 574D*WA, 577C, 577E (460 VAC models), 674D “B” series or later (Examples: 674DNW060130NB, 674DPW060130NB, 674DEW060130NB), 674D*WA, 677C, all PY3G **except** “B” series (Example: PY3GNA060115AB) and PY4G. (Single-Stage conversion starts on Page 2.)

NOTE: Read the entire instruction manual before starting the installation.

SAFETY CONSIDERATIONS

Improper installation, adjustment, alteration, service maintenance, or use can cause explosion, fire, electrical shock, or other conditions which may cause death, personal injury, or property damage. Consult a qualified installer, service agency, or your distributor or branch for information or assistance. The qualified installer or agency must use factory-authorized kits or accessories when modifying this product. Refer to the individual instructions packaged with the kits or accessories when installing.

Follow all safety codes. Wear safety glasses, protective clothing, and work gloves. Have a fire extinguisher available. Read these instructions thoroughly and follow all warnings or cautions included in literature and attached to the unit. consult local building codes, the current editions of the National Fuel Gas Code (NFGC) NFPA 54/ANSI Z223.1, and the National Electrical Code (NEC) NFPA 70.

In Canada refer to the current editions of the National Standards of Canada CAN/CSA-B149.1 and .2 Natural Gas and Propane Installation codes, and Canadian Electrical Code CSA C22.1

Recognize safety information. This is the safety-alert symbol . When you see this symbol on the unit and in instructions or manuals, be alert to the potential for personal injury. Understand these signal words: DANGER, WARNING, and CAUTION. These words are used with the safety-alert symbol. DANGER identifies the most serious hazards which **will** result in severe personal injury or death. WARNING signifies hazards which **could** result in personal injury or death. CAUTION is used to identify unsafe practices which **may** result in minor personal injury or product and prop-

erty damage. NOTE is used to highlight suggestions which **will** result in enhanced installation, reliability, or operation.

WARNING

FIRE, EXPLOSION, CARBON MONOXIDE POISONING, PROPERTY DAMAGE HAZARD

Failure to follow this warning could result in personal injury, death or property damage.

This conversion kit shall be installed by a qualified service agency in accordance with the manufacturer’s instructions and all applicable codes and requirements of the authority having jurisdiction. The qualified service agency is responsible for the proper installation of this kit. The installation is not proper and complete until the operation of the converted furnace is checked as specified in the manufacturer’s instructions supplied in the kit.

AVERTISSEMENT

FEU, EXPLOSION, EMPOISONNEMENT PAR CARBON DE MONOXYDE, RISQUE DE DOMMAGE À LA PROPRIÉTÉ

La négligence de suivre l’avis suivant, peut causer des blessures personnelles, la mort ou du dommage à la propriété.

Cette trousse de conversion doit être installée par un Entrepreneur qualifié, selon les instructions du fabricant et doit se conformer à toutes les exigences et tout les codes pertinents de l’autorité compétente. L’Entrepreneur qualifié est responsable, et doit s’assurer de bien suivre les instructions dans cet avis. L’installation sera considérée conforme et rencontrant les spécifications et instructions du fabriquant qui sont inclus dans la trousse, seulement après vérification de l’opération de la fournaise convertie.

⚠ CAUTION

UNIT OPERATION HAZARD

Failure to follow this caution may result in damage to unit components.

Before converting a unit to propane gas, remove the burner assembly and inspect the heat exchanger tubes. If there are V-shaped NOx baffles installed in the firing tubes, (see Fig. 1). THEY MUST BE REMOVED PRIOR TO CONVERTING THIS UNIT TO PROPANE GAS.

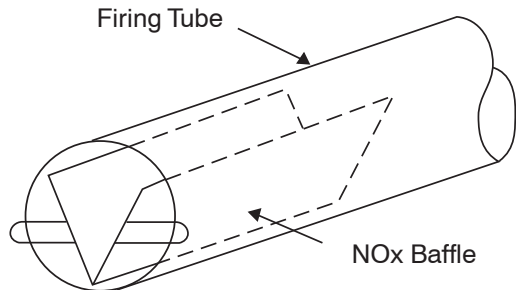

Fig. 1 - Low NOx Baffle Location

A01051

⚠ WARNING

EXPLOSION, PERSONAL INJURY HAZARD

Failure to follow this warning could result in personal injury or death.

This unit is designed to operate at a minimum 10.0 IN. W.C. of manifold pressure on high stage with propane gas. Refer to Table 8 for proper manifold pressure settings for high stage and low stage.

SINGLE-STAGE KIT INTRODUCTION

These instructions cover the installation of a propane gas conversion kit on models 48ES "1" series or later (Examples: 48ES-060130311, 48ES-060130511, 48ES-060130611), 48ES-A, 48ESNA, 48EZ "1" series or later (Examples: 48EZ-060130311, 48EZ-060130511, 48EZ-060130611), 48EZ-A, 48EZNA, 48VG (460 VAC models), 48VL, 48VT, 574D "B" series or later (Examples: 574DNW060130NB, 574DPW060130NB, 574DEW060130NB), 574D*WA, 674D "B" series or later (Examples: 674DNW060130NB, 674DPW060130NB, 674DEW060130NB), 674D*WA, 577C, 577E (460 VAC models), 677C, all PY3G **except** "B" series (Example: PY3GNA060115AB) and PY4G.

DESCRIPTION AND USAGE

This single-stage kit is applicable to units with heating inputs from 40,000 to 130,000 Btu/hr installed at high altitudes from 2001 ft to 6000 ft. (610 to 1829 m). They cannot be used for standard altitude installation. Standard altitude conversion (0-2000 ft) (0-610 m) must use kit CPLPCONV013C00.

SINGLE-STAGE KIT INSTALLATION

⚠ WARNING

FIRE, EXPLOSION, ELECTRICAL HAZARD

Failure to follow this warning could result in personal injury, death or property damage.

Gas supply **MUST** be shut off before disconnecting electrical power and proceeding with conversion.

⚠ WARNING

ELECTRICAL SHOCK HAZARD

Failure to follow this warning could result in personal injury or death.

Before installing or servicing system, always turn off main power to system and install lockout tag. There may be more than one disconnect switch. Lock out and tag switch with suitable warning label.

1. Turn off gas supply first, then power to unit.
2. Remove the control access panel from unit.
3. Disconnect the gas pipe from the gas valve.
4. Remove the screw attaching the gas manifold to the basepan, and partially slide out the entire burner rack assembly from unit. Save screw. The fan partition mounting bracket may be removed for easier access to the burner assembly. The bracket may be removed for easier access to the burner assembly. The bracket may be removed by removing 2 screws (located on the left side of the control compartment on the fan partition panel) and sliding the bracket forward, bottom first. See Fig. 7.)
5. Disconnect the gray and brown wires from the gas valve and remove blue wires from the rollout switch.

NOTE: To locate rollout switch, see Fig. 2.

6. Disconnect orange sparker cable from the sparker.
7. Disconnect yellow flame sensor wire from the flame sensor.
8. Remove the screw securing the brown wire from the burner assembly. Ground screw is attached to the fan partition panel. Save screw.
9. Completely slide out the entire burner rack assembly from unit.
10. Inspect the inlet of the heat exchanger tubes for presence of V-shaped NOx baffles (see Fig. 1). If baffles are present, they must be removed prior to converting unit for propane gas. Using needle-nose pliers, remove NOx baffles, squeeze sides of the baffle, if necessary, to remove from the heat exchanger tubes.

IMPORTANT: If it is expected that this unit will be converted back to natural gas at a later time, these baffles should be retained for reuse. Otherwise the baffles may be discarded.

11. Using a 5/16 in. nut driver, remove the four screws securing the manifold/gas valve assembly to the burner assembly. Save these screws.
12. For certain 40,000 Btu/hr and all 3 cell 60,000 Btu/hr units only (refer to Table 5)! Remove the burners from the rack, and save the screws. Remove the snap ring from the end of each burner (see Fig. 12). Refer to Table 5 for correct burner insert for specific model. Install burner insert in the end of each burner with the flat sides of the square vertical and horizontal. Replace the snap ring to retain the burner insert (see

Fig. 12 for snap ring orientation) for each burner. Replace the burners in the rack using the saved screws, making sure closed crossovers of burners are at each end.

13. Remove the natural gas orifices from the manifold using a 9/16 in. wrench and install the correct propane gas orifices in the manifold (See Table 8 to select correct orifice size based on rated input and altitude. See Fig. 3 and 5 for orifice installation).
14. Replace the manifold/gas valve assembly into the burner assembly using the four screws saved from Step 11.
15. Remove the plug on the inlet end of the gas valve using a 3/16 in. hex wrench.
16. Install the 1/8 in. NPT x 3/4 in. (19 mm) close pipe nipple where the plug was removed (see Fig. 6). Use pipe thread dope (field-supplied, must be certified for use with propane gas) for all joints, making sure not to get any excess in the pipe or valve. Next, install a 1/8 in. elbow, a 1/8 in. NPT x

3/4 in. (19 mm) close pipe nipple, 1/8 in. elbow, 1/8 in. x NPT 2 in. (51 mm) nipple, and a low gas pressure switch as shown in Fig.6.

17. Remove regulator cover screw from the gas regulator (see Fig. 4). Save regulator cover screw.
18. Using a screwdriver, remove the plastic regulator adjust screw from the gas regulator (see Fig. 4). Save plastic regulator adjust screw.
19. Remove regulator spring (silver) from the gas regulator (see Fig. 4). Discard regulator spring.
20. Install propane gas regulator spring (white) shipped with this kit. (See Fig. 4).
21. Install plastic adjust screw into the gas regulator, turn clockwise 13.5 turns (see Fig. 4).
22. Verify igniter, flame sensor, orifice/main burner relationship prior to completing conversion. (See Fig. 3.) Partially slide burner rack assembly into unit.

Table 1 – Single-Stage Kit Contents

ITEM	PART NO.	QUANTITY
Installation Instructions	IICPLPCONV–24	1
Propane Gas Orifice #50*	LH32RF070	3
Propane Gas Orifice #51*	LH32RF067	3
Propane Gas Orifice #52*	LH32RF065	3
Propane Gas Orifice #53*	LH32RF060	3
Propane Gas Orifice #54*	LH32RF055	3
Propane Gas Orifice #56*	LH32RF047	3
Regulator Spring (92–0659)	EF39ZW023	1
Pressure Switch	HK02LB008	1
90° Elbow, 1/8 in. NPT	CA05RA001	2
Nipple, 1/8 in. NPT x 2 in. (51 mm)	CA01CA010	1
Close Pipe Nipple, 1/8 in. NPT x 3/4 in. (19 mm)	CA01CA001	2
Wire Harness	48DU400080	1
Propane Conversion Label (Rating Plate)	48VL500383	1
Propane Conversion Label (Installer Responsibility)	48VL500384	1
Propane Conversion Warning Label (Gas Valve)	48DU500076	1
Burner Insert	50CY502897	3

*Refer to Table 8 to determine the correct orifice to use.

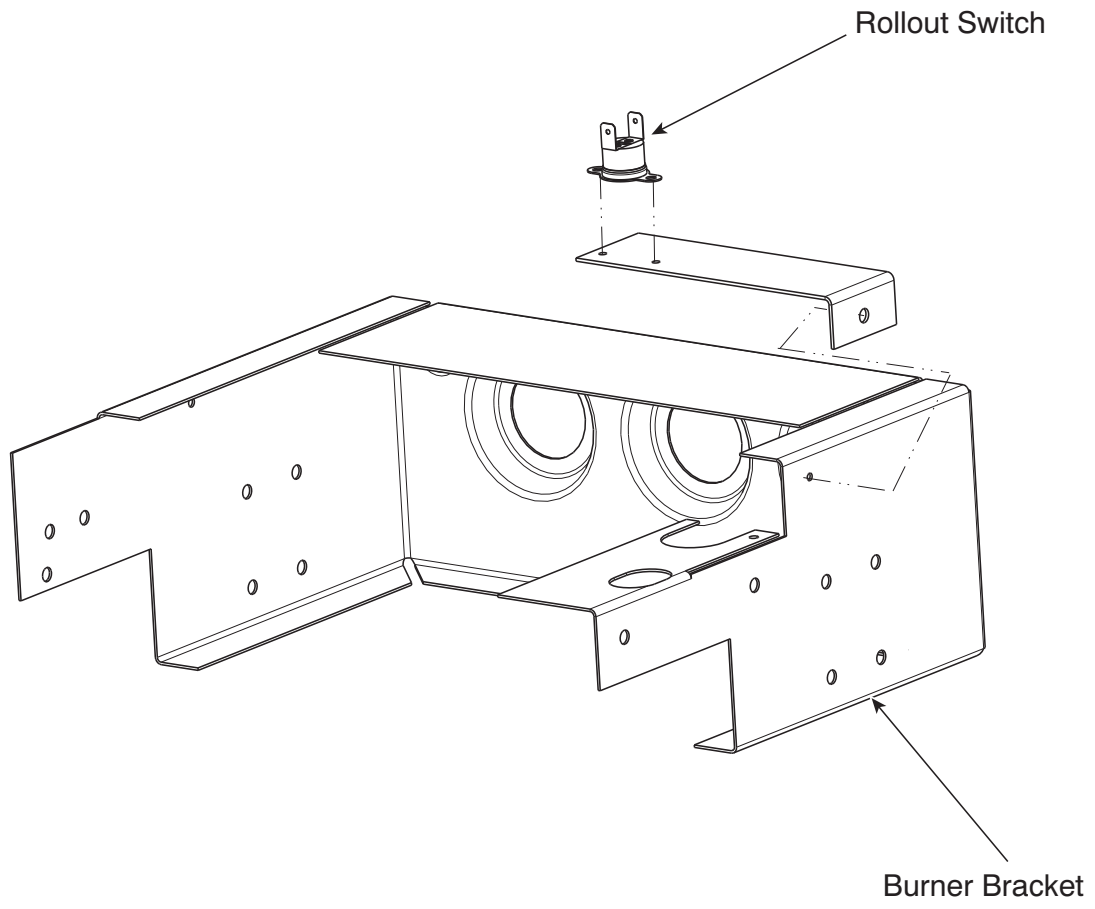

Fig. 2 - Single-Stage Burner Bracket

A07874

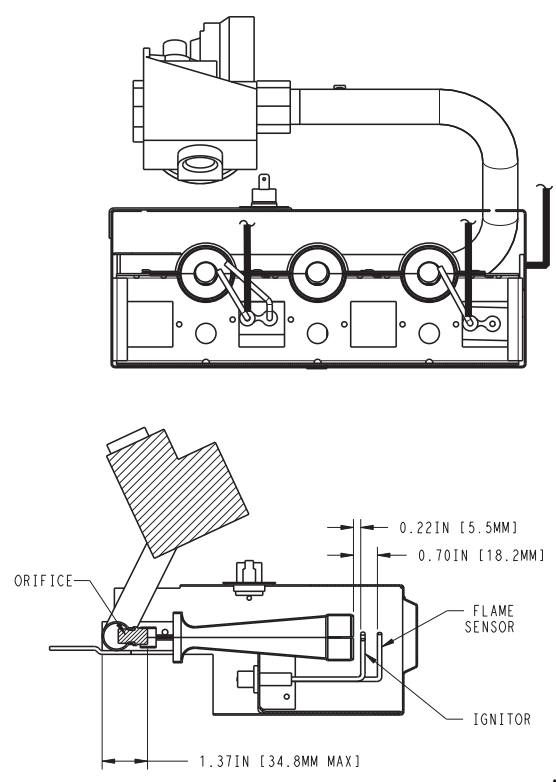
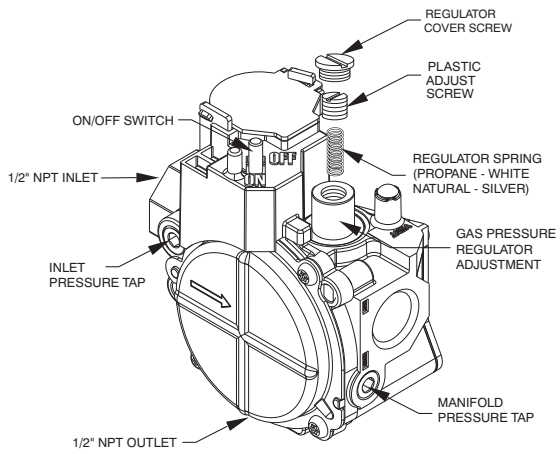

Fig. 3 - Single-Stage Igniter, Flame Sensor, Orifice/Main Burner Relationship

A07890



A07808

Fig. 4 - Single-Stage Gas Valve

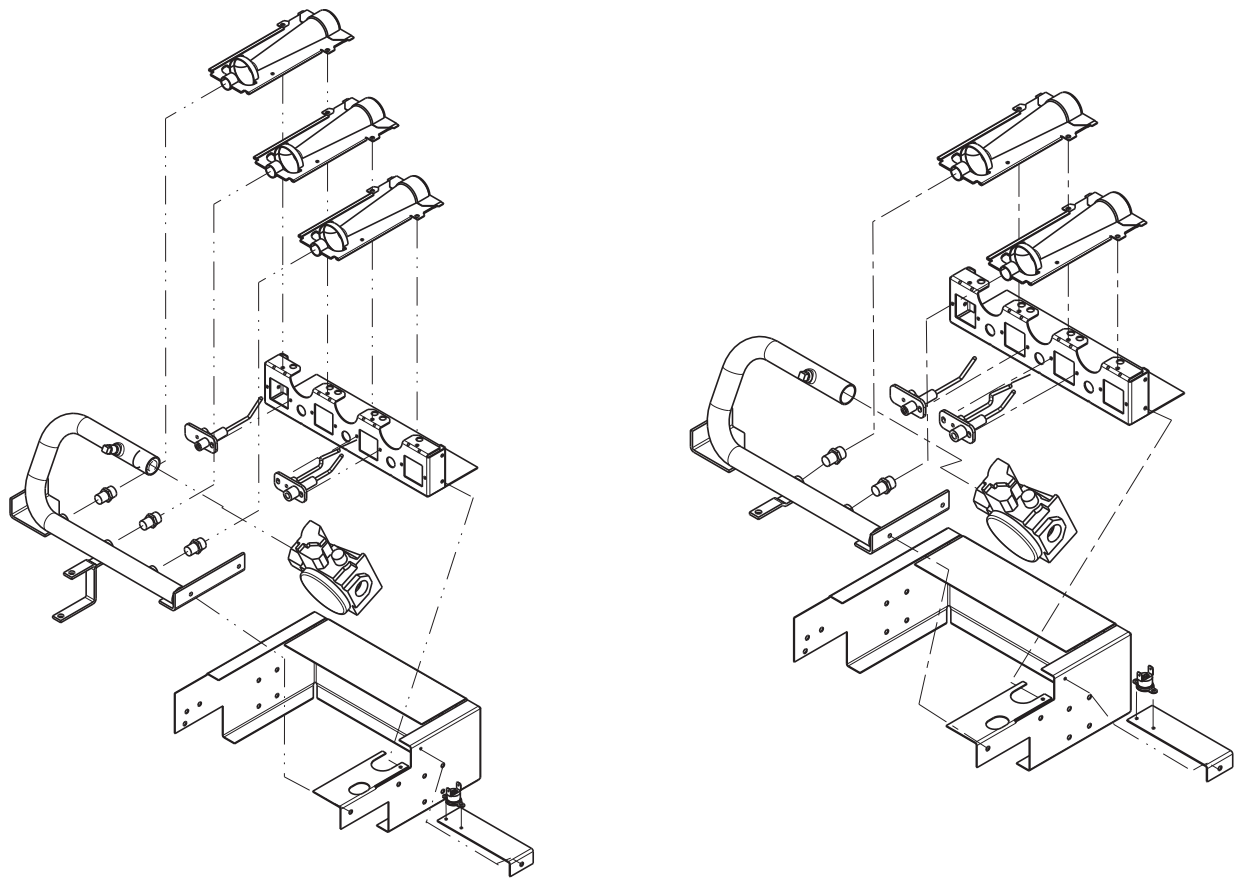

3 Cell 60,000 BTUH, 90,000 BTUH to 130,000 BTUH Units

40,000 BTUH and 2 Cell 60,000 BTUH Units

Fig. 5 - Single-Stage Orifice Installation

A14635

23. Disconnect the orange wire from the combustion air pressure switch and connect it to the orange wire on the low gas pressure switch (LGPS) equipped with a 1/4 in. male quick-connect terminal. The low gas pressure switch should have one unconnected orange wire remaining. Connect this wire to the vacant terminal on the combustion air pressure switch (see Fig. 13).
24. Reconnect the blue wires removed in Step 5 to the rollout switch and reinstall the rollout switch.
25. Reconnect orange sparker cable to sparker and reconnect the yellow flame sensor wire to the flame sensor.
26. Reconnect the gray and brown wires removed in Step 5 to the gas valve.
27. Slide burner rack assembly into base pan. Align burner rack with screws on sheet metal partition and slide assembly back tight to the partition. Replace the screw attaching the burner rack to the base pan removed in step 4. If the fan partition mounting bracket was removed, slide bracket back into place and fasten with 2 screws (see Fig. 7).
28. Reconnect the brown wire from the burner assembly to the fan partition panel, using the ground screw saved from step 8.
29. Remove the 1/8 in. pipe plug on the gas manifold and connect a pressure manometer (see Fig. 10).
30. Reconnect electrical power and gas supply to the unit. For propane applications, the gas pressure must not be less than 11.0 IN. W.C. or greater than 13 IN. W.C. at the unit connection. A 1/8-in. NPT plugged tapping, accessible for test gauge connection, must be installed immediately upstream of the gas supply connection to the gas valve and downstream of manual equipment shutoff valve.

The newly installed low gas pressure switch is a safety device used to guard against adverse burner operating characteristics that can result from low gas supply pressure. Switch opens at not less than 6.5 IN. W.C. and closes at not greater than 10.2 IN. W.C.

This switch also prevents operation when the propane tank level is low which can result in gas with a high concentration of impurities, additives, and residues that have settled to the bottom of the tank. Operation under these conditions can cause harm to the heat exchanger system.

This normally open switch closes when gas is supplied to gas valve under normal operating pressure. The closed switch completes control circuit. Should an interruption or reduction in gas supply occur, the gas pressure at switch drops below low gas pressure switch setting, and switch opens. Any interruption in control circuit (in which low gas pressure switch is wired) quickly closes gas valve and stops gas flow to burners.



WARNING

FIRE AND EXPLOSION HAZARD

Failure to follow this warning could result in personal injury and/or property damage.

Never test for gas leaks with an open flame. Use a commercially available soap solution made specifically for the detection of leaks to check all connections. A fire or explosion may result causing property damage, personal injury or loss of life.

IMPORTANT: Restart unit and leak check all gas connections including the main service connection, gas valve, gas spuds, and manifold pipe plug. All leaks must be repaired before firing unit.

31. Fire unit and verify proper ignition and proper sequence of operation (Table 2). See Table 8 for proper manifold pressure setting for your unit. Adjust the gas valve setting by turning the plastic adjustment screws clockwise to increase pressure and counter-clockwise to decrease pressure. Refer to Table 3 for required rated heating input rates. Replace regulator cover screws when finished (see Fig. 4).
32. With control access panel removed, observe unit heating operation. Watch burner flames to see if they are blue in appearance, and that the flames are approximately the same for each burner (see Fig. 14).
33. Turn off unit, remove pressure manometer and replace the 1/8 in. pipe fitting on the gas manifold (see Fig. 10).
34. Attach warning label (P/N 48DU500076) to visible side of gas valve.
35. Attach conversion label (P/N 48VL500383) above unit rating plate on exterior of unit.
36. Attach completed conversion responsibility label (see Fig. 15, P/N 48VL500384) inside control access panel.

IMPORTANT: Restart unit and leak check all gas connections including the main service connection, gas valve, gas spuds, and manifold pipe plug.



WARNING

FIRE AND EXPLOSION HAZARD

Failure to follow this warning could result in personal injury and/or property damage.

Never test for gas leaks with an open flame. Use a commercially available soap solution made specifically for the detection of leaks to check all connections. A fire or explosion may result causing property damage, personal injury or loss of life.

37. After all leaks are eliminated, replace control access panel.

Table 2 – Single-Stage Sequence of Operations

For Units With a Separate Blower Fan Control Board

Trial-for-Ignition Sequence: The ignition sequence is to immediately energize the inducer motor on a call for heat. Within approximately 5 sec of the call for heat, the gas valve will open and the igniter will spark. Seven sec will be allowed to prove flame sense on the far burner.
Flame-Proving: Once flame is proven, the control will wait an additional 45 sec to energize the indoor blower motor. On removal of the call for heat, the gas valve will immediately shut down, the inducer motor will run for an additional 5 sec, and the indoor blower will run for an additional 45 sec (minimum).

For Units With an Integrated Ignition/Blower Fan Control

Trial-for-Ignition Sequence: The ignition sequence is to turn on the inducer motor for 5 second pre-purge after a call for heat is established. The gas valve will then open and the igniter will spark. Seven seconds will be allowed to prove flame to sense on the far burner.
Flame-Proving: Once flame is proven, the control will wait an additional 30 sec to energize the indoor blower motor. On removal of the call for heat, the gas valve will immediately shut down, the inducer motor will run for an additional 5 sec, and the indoor blower will run for an additional 90 sec (minimum).

Table 3 – Single-Stage Rated Heating Input, Propane Gas (2001-6000 ft [610-1829 m] Altitude)

High Altitude Compensation, Propane Gas - Single Phase Models

Nameplate Input (Btu/hr)	Rated Heating Input (Btu/hr), LP Gas at Installation Altitude Above Sea Level, U.S.A.*				
	0 to 2000 ft (0-610 m)	2001 to 3000 ft* (611 to 914 m)	3001 to 4000 ft (915 to 1219 m)	4001 to 5000 ft (1220 to 1524 m)	5001 to 6000 ft (1524 to 1829 m)
40000	38000	31700	31700	31700	31200
60000	57000	47500	47500	47500	46900
90000	79000	68900	68900	68600	68600
115000	103000	100400	98900	83000	83000
127000	116000	115500	111800	101300	100400

*In the U.S.A., the input rating for altitudes above 2000 ft (610m) must be reduced by 4% for each 1000 ft (305 m) above sea level. In Canada, the input rating for altitudes from 2001 to 4500 ft (611 to 1372 m) above sea level must be derated by 10% by an authorized gas conversion station or dealer. For Canadian Installations from 2000 to 4500 ft (610-1372 m), use U.S.A. column 2001 to 3000 ft (611 to 914 m).

High Altitude Compensation, Propane Gas - Three Phase Models

Nameplate Input (Btu/hr)	Rated Heating Input (Btu/hr), LP Gas at Installation Altitude Above Sea Level, U.S.A.*				
	0 to 2000 ft (0-610 m)	2001 to 3000 ft* (611 to 914 m)	3001 to 4000 ft (915 to 1219 m)	4001 to 5000 ft (1220 to 1524 m)	5001 to 6000 ft (1524 to 1829 m)
40000	38000	31700	31700	31700	31200
60000	53000	45900	45900	45800	45800
90000	79000	68900	68900	68600	68600
115000	103000	100400	98900	83000	83000
130000	116000	115500	111800	101300	100400

*In the U.S.A., the input rating for altitudes above 2000 ft (610m) must be reduced by 4% for each 1000 ft (305 m) above sea level. In Canada, the input rating for altitudes from 2001 to 4500 ft (611 to 1372 m) above sea level must be derated by 10% by an authorized gas conversion station or dealer. For Canadian Installations from 2000 to 4500 ft (610-1372 m), use U.S.A. column 2001 to 3000 ft (611 to 914 m).

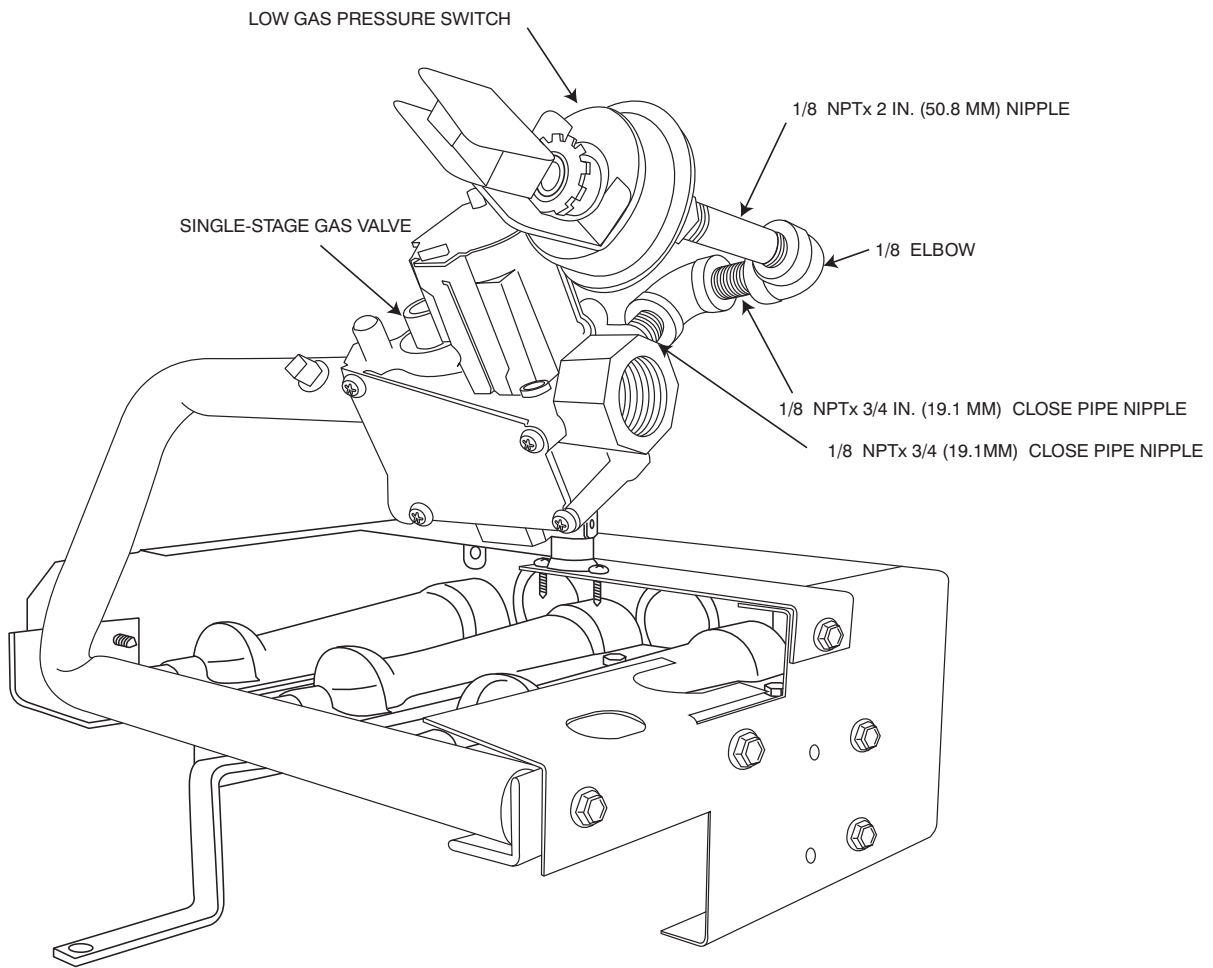

Fig. 6 - Installing Elbows, Nipples, and Pressure Switch on Single-Stage Units

A09017

TWO-STAGE KIT INTRODUCTION

These instructions cover the installation of a propane gas conversion kit on models 48DT, 48DU, 48VG (208/230 VAC models), 48VR, 48XL, 48XT, 577B, 577D, 577E (208/230 VAC models), 677B, 677D and 677E that are equipped with a White Rodgers 2-stage combination automatic gas valve regulator.

DESCRIPTION AND USAGE

This Two-Stage kit is applicable to units with heating inputs from 40,000 to 130,000 Btu/hr installed at high altitudes from 2001 ft to 6000 ft (610-1829 m). It cannot be used for standard altitude installation. Standard altitude conversion (0-2000 ft) (0-610 m) must use kit CPLPCONV013C00.

TWO-STAGE KIT INSTALLATION

WARNING

FIRE, EXPLOSION, ELECTRICAL HAZARD

Failure to follow this warning could result in personal injury, death or property damage.

Gas supply **MUST** be shut off before disconnecting electrical power and proceeding with conversion.

WARNING

ELECTRICAL SHOCK HAZARD

Failure to follow this warning could result in personal injury or death.

Before installing or servicing system, always turn off main power to system and install lockout tag. There may be more than one disconnect switch. Lock out and tag switch with a suitable warning label.

1. Turn off gas supply first, then power to unit.
2. Remove the control access panel from unit.
3. Disconnect the gas pipe from the gas valve.
4. Remove the screw attaching the gas manifold to the basepan, and partially slide out the entire burner rack assembly from unit. Save screw. The fan partition mounting bracket may be removed for easier access to the burner assembly. The bracket may be removed by removing 2 screws (located on the left side of the control compartment on the fan partition panel) and sliding the bracket forward, bottom first. See Fig. 7.
5. Disconnect the gray, blue, brown and green/yellow wires from the gas valve and remove blue or violet wires from the rollout switch.

NOTE: To locate rollout switch, see Fig. 8.

6. Disconnect orange sparker cable from the sparker.
7. Disconnect white flame sensor wire from the flame sensor.

CPLPCONV

Table 4 – Two-Stage Kit Contents

ITEM	PART NO.	QUANTITY
Installation Instructions	I1K-CPLPCONV-24	1
Propane Gas Orifice #50*	LH32RF070	3
Propane Gas Orifice #51*	LH32RF067	3
Propane Gas Orifice #52*	LH32RF065	3
Propane Gas Orifice #53*	LH32RF060	3
Propane Gas Orifice #54*	LH32RF055	3
Propane Gas Orifice #56*	LH32RF047	3
Regulator Spring (92-0659)	EF39ZW023	2
Pressure Switch	HK02LB008	1
90° Elbow, 1/8 in. NPT	CA05RA001	2
Nipple, 1/8 in. NPT x 2 in. (51 mm)	CA01CA010	1
Close Pipe Nipple, 1/8 in. NPT x 3/4 in. (19 mm)	CA01CA001	2
Wire Harness	48DU400080	1
Propane Conversion Label (Rating Plate)	48VL500383	1
Propane Conversion Label (Installer Responsibility)	48VL500384	1
Propane Conversion Warning Label (Gas Valve)	48DU500076	1
Burner Insert	48GS500465	3
Burner Insert	50CY502897	3

*Refer to Table 8 to determine the correct orifice to use.

8. Remove the ground screw securing the brown wire from the burner assembly. Ground screw is attached to the fan partition. Save screw.
9. Completely slide out the entire burner rack assembly from unit.
10. Inspect the inlet of the heat exchanger tubes for presence of V-shaped NOx baffles (see Fig. 1). If baffles are present, they must be removed prior to converting unit for propane gas. Using needle-nose pliers, remove NOx baffles, squeeze

sides of the baffle, if necessary, to remove from the heat exchanger tubes.

IMPORTANT: If it is expected that this unit will be converted back to natural gas at a later time, these baffles should be retained for reuse. Otherwise the baffles may be discarded.

11. Using a 5/16 in. nut driver, remove the four screws securing the manifold/gas valve assembly to the burner assembly. Save these screws.

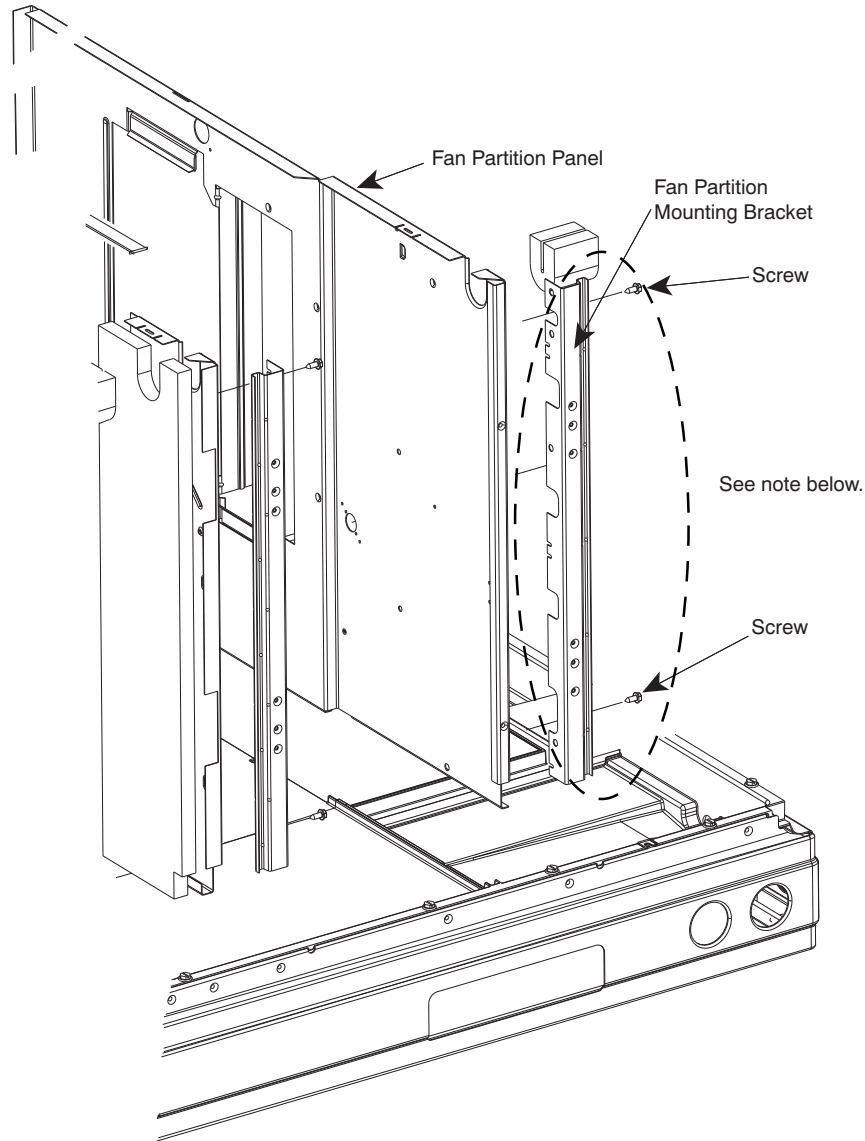

NOTE: The fan partition bracket may be removed for easier access to the burner assembly. The bracket may be removed by removing 2 screws on the control side and sliding the bracket forward, bottom first.
If the fan partition bracket was removed, slide bracket back into place and fasten with 2 screws.

Fig. 7 - Fan Partition Bracket Removal

A09320

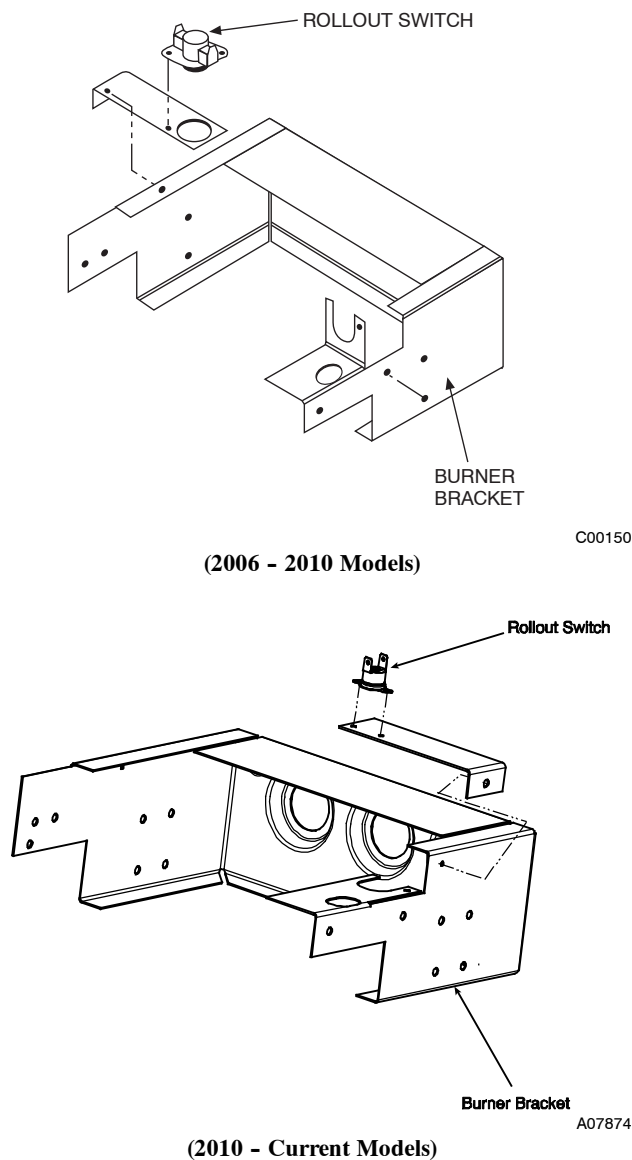

Fig. 8 - Two-Stage Burner Bracket

12. For 2-stage 40,000 Btu/hr and 60,000 Btu/hr only. Remove the burners from the rack, save the screws (see Fig. 12). Remove the snap ring from the end of each burner. Refer to Table 5 for correct burner insert for specific model. Install burner insert in the end of each burner with the flat sides of the square vertical and horizontal. Replace the snap ring to retain burner insert (see Fig. 12 for correct orientation). Replace the burners in the rack using the saved screws, making sure closed crossovers of burners are at each end.
13. Remove the natural gas orifices from the manifold using a 9/16 in. wrench and install the correct propane gas orifices in the manifold (See Table 8 to select correct orifice size based on rated input and altitude. See Fig. 9 and 12 for orifice installation).
14. Replace the manifold/gas valve assembly into the burner assembly using the four screws saved from step 11.
15. Remove the plug on the inlet end of the gas valve using a 3/16 in. hex wrench.

Table 5 – Burner Insert Usage (40 and 60 kBtu Units Only)

Model	Applicable Heating Input Sizes (kBtu/hr)	Burner Insert P/N
48VG(-,N)B,E	40, 60	50CY502897
48VL(-,N)(B,C,D,E)*****3	40, 60	
48VR(-,N)(B,C,E)	40, 60	
48VT(-,N)(B,C,E)*****3	40, 60	
577CNW(B,C,D,E)	40, 60	
577ENW(B,E)	40, 60	
677CNW(B,C,E)	40, 60	
677ENW(B,C,E)	40, 60	
PY4GN	40, 60	
48DU	40, 60	
48DT	40, 60	
48VG(-,N)A	40, 60	
48VR(-,N)A	40, 60	
48XL	40, 60	
48XT	40, 60	
577B	40, 60	
577D	40, 60	
577ENWA	40, 60	
677B	40, 60	
677D	40, 60	
677ENWA	40, 60	

CPLPCONV

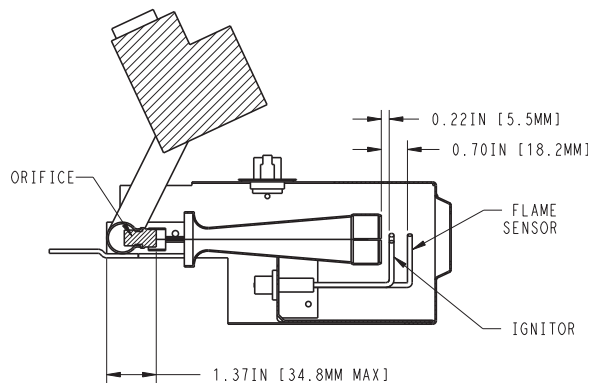
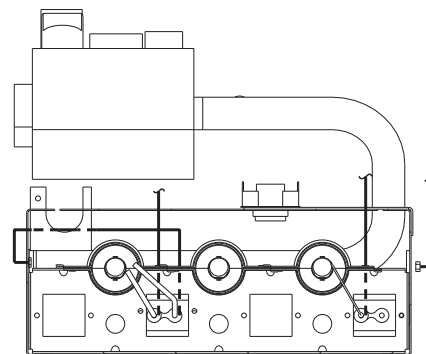
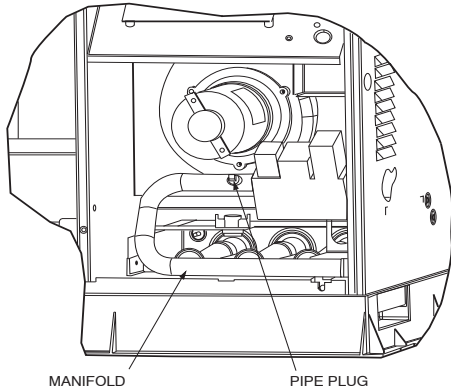

Fig. 9 - Two-Stage Igniter, Flame Sensor, Orifice/Main Burner Relationship

16. Install the 1/8 in. NPT x 3/4 in. (19 mm) close pipe nipple where the plug was removed (see Fig. 16). Use pipe thread dope (field-supplied, must be certified for use with propane gas) for all joints, making sure not to get any excess in the pipe or valve. Next, install a 1/8 in. elbow, a 1/8 in. NPT x 3/4 in. (19 mm) close pipe nipple, 1/8 in. elbow, 1/8 in. x NPT 2 in. (51 mm) nipple, and a low gas pressure switch as shown in Fig. 16.
17. Remove regulator cover screws for both high and low stage gas regulators (see Fig. 11). Save regulator cover screws.

18. Using a screwdriver, remove plastic adjust screws from both high and low stage gas regulators (see Fig. 11). Save plastic adjust screws.
19. Remove regulator springs (silver) from both high and low stage gas regulators (see Fig. 11). Discard regulator springs.
20. Install propane gas regulator springs (white) shipped with this kit. One into the low stage gas regulator and one into the high stage gas regulator (see Fig. 11).
21. Install plastic adjust screw into the high stage gas regulator. turn clockwise 13.5 turns (see Fig. 11).



C99019

Fig. 10 - Burner Assembly

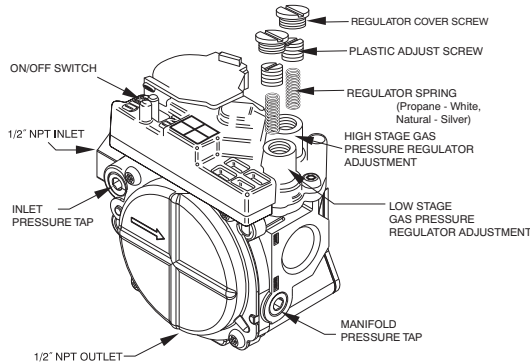

A07804

Fig. 11 - Two-Stage Gas Valve

22. Install plastic adjust screw into the low stage gas regulator. turn clockwise 9.5 turns (see Fig. 11).
23. Verify igniter, flame sensor, orifice/main burner relationship prior to completing conversion. (See Fig. 9.) Partially slide burner rack assembly into unit.
24. Disconnect the orange wire from the combustion air pressure switch and connect it to the orange wire on the low gas pressure switch (LGPS) equipped with a 1/4 in. male quick-connect terminal. The low gas pressure switch should have one unconnected orange wire remaining. Connect this wire to the vacant terminal on the combustion air pressure switch (see Fig. 13).
25. Reconnect the blue or violet wires removed in item 5 to the rollout switch and reinstall the rollout switch.
26. Reconnect orange sparker cable to sparker and reconnect the white flame sensor wire to the flame sensor.
27. Reconnect the remaining wires removed in Step 5 to the gas valve. Connect the gray wires to (HI). Connect the blue wires to (M). Connect the brown and green/yellow wires to (C).
28. Slide burner rack assembly into base pan. Align burner rack with screws on sheet metal partition and slide assembly back tight to the partition. Replace the screw attaching the burner rack to the base pan removed in step 4. If the Fan partition mounting bracket was removed, slide bracket back into place and fasten with 2 screws. (See Fig. 7.)

29. Reconnect the brown wire from the burner assembly to the fan partition panel, using the ground screw saved from Step 8.
30. Remove the 1/8 in. pipe plug on the gas manifold and connect a pressure manometer (see Fig. 10).
31. Reconnect electrical power and gas supply to the unit. For propane applications, the gas pressure must not be less than 11.0 IN. W.C. or greater than 13 IN. W.C. at the unit connection. A 1/8-in. NPT plugged tapping, accessible for test gauge connection, must be installed immediately upstream of the gas supply connection to the gas valve and downstream of manual equipment shutoff valve.

The newly installed low gas pressure switch is a safety device used to guard against adverse burner operating characteristics that can result from low gas supply pressure. Switch opens at not less than 6.5 IN. W.C. and closes at not greater than 10.2 IN. W.C.

This switch also prevents operation when the propane tank level is low which can result in gas with a high concentration of impurities, additives, and residues that have settled to the bottom of the tank. Operation under these conditions can cause harm to the heat exchanger system.

This normally open switch closes when gas is supplied to gas valve under normal operating pressure. The closed switch completes control circuit. Should an interruption or reduction in gas supply occur, the gas pressure at switch drops below low gas pressure switch setting, and switch opens. Any interruption in control circuit (in which low gas pressure switch is wired) quickly closes gas valve and stops gas flow to burners.

⚠ WARNING

FIRE AND EXPLOSION HAZARD

Failure to follow this warning could result in personal injury and/or property damage.

Never test for gas leaks with an open flame. Use a commercially available soap solution made specifically for the detection of leaks to check all connections. A fire or explosion may result causing property damage, personal injury or loss of life.

IMPORTANT: Restart unit and leak check all gas connections including the main service connection, gas valve, gas spuds, and manifold pipe plug. All leaks must be repaired before firing unit.

32. Fire unit and verify proper ignition and proper sequence of operation (Table 6). See Table 8 for proper low stage and high stage manifold pressure settings for your unit. Adjust the gas valve setting for high and low stages by turning the plastic adjustment screws clockwise to increase pressure and counter-clockwise to decrease pressure for the respective stages. Refer to Table 7 for required rated heating input rates. Replace regulator cover screws when finished (see Fig. 11).
33. With control access panel removed, observe unit heating operation in both low stage operation and high stage operation. Watch burner flames to see if they are blue in appearance, and that the flames are approximately the same for each burner (see Fig. 14).
34. Turn off unit, remove pressure manometer and replace the 1/8 in. pipe fitting on the gas manifold (see Fig. 10).
35. Attach warning label (P/N 48DU500076) to visible side of gas valve.
36. Attach conversion label (P/N 48VL500383) above unit rating plate on exterior of unit.
37. Attach completed conversion responsibility label (see Fig. 15, P/N 48VL500384) inside control access panel.

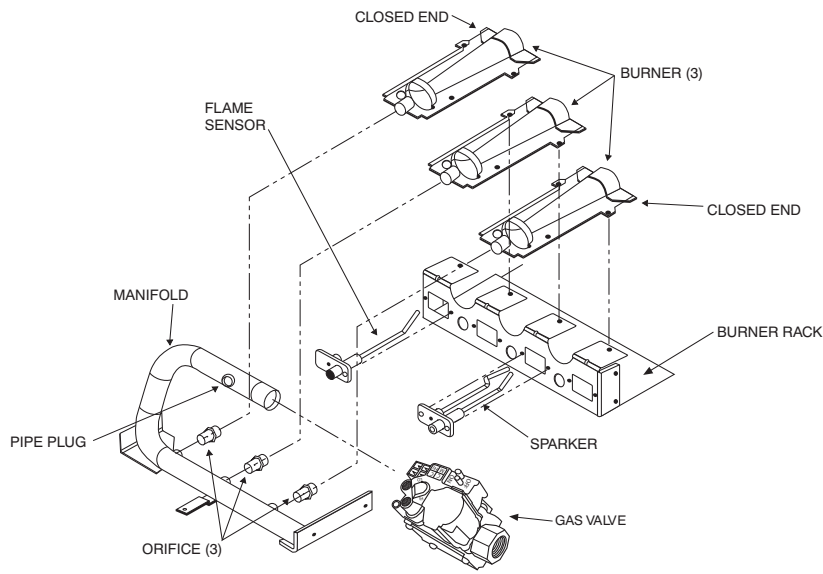

90,000 BTUH TO 130,000 BTUH UNITS

A14641

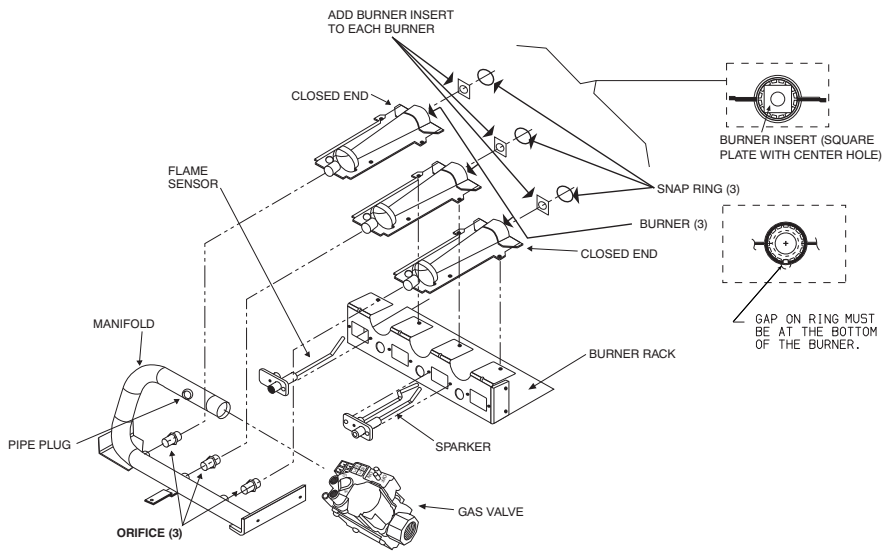

3-CELL 60,000 BTUH UNITS

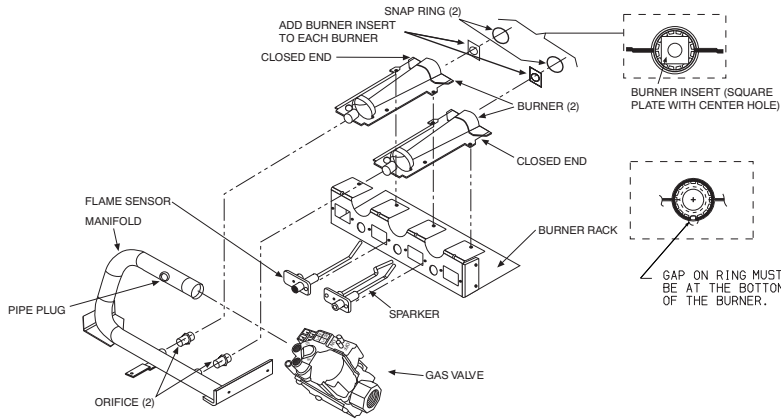

40,000 BTUH UNITS

Fig. 12 - Orifice and Burner Insert Installation

A150780

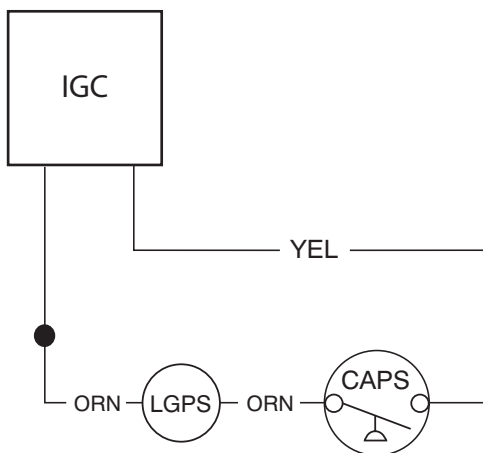

LEGEND
 ORN = ORANGE
 YEL = YELLOW
 LGPS = LOW GAS PRESSURE SWITCH
 CAPS = COMBUSTION AIR PRESSURE SWITCH
 IGC = INTEGRATED GAS CONTROL
 ● = QUICK CONNECTION

Fig. 13 - Pressure Switch Wiring

A14614

Table 6 – Two-Stage Sequence of Operations

<p>Inducer Pre-Purge Period: When the inducer motor comes up on high speed, the pressure switch closes, and the ignition control on the furnace board begins a 15 sec pre-purge period. If the pressure switch fails to remain closed, the inducer will remain running. After the pressure switch recloses, the Infinity ignition control will begin a 15 sec pre-purge period.</p>
<p>Trial-for-Ignition Sequence: The spark igniter will spark for 3 sec, the main gas valve relay contact closes to energize the gas valve on low stage. After 5 sec, the igniter is de-energized and a 2-sec flame-proving period begins.</p>
<p>NOTE: The unit always lights on high speed inducer and low stage gas valve operation.</p>
<p>Flame-Proving: When the burner flame is proved at the flame-proving sensor, the furnace control determines what heating stage to run based on feedback from the thermostat. If the thermostat is asking for low stage gas heat, the ignition control will change the inducer speed to low speed and keep the gas valve energized on low stage. If the thermostat is asking for high stage gas heat, the ignition control will maintain running the inducer on high speed and energize the gas valve's high stage relay to increase gas flow.</p>

Table 7 – Two-Stage Rated Heating Input, Propane Gas (2001-6000 ft [610-1829 m] Altitude)

Nameplate Input, High Stage (Btu/hr)	Rated Heating Input (Btu/hr), LP Gas at Installation Altitude Above Sea Level, U.S.A.*									
	0 to 2000 ft 0 to 610 m		2001 to 3000 ft* 610 to 914 m		3001 to 4000 ft 915 to 1219 m		4001 to 5000 ft 1220 to 1524 m		5001 to 6000 ft 1524 to 1829 m	
	High Stage	Low Stage	High Stage	Low Stage	High Stage	Low Stage	High Stage	Low Stage	High Stage	Low Stage
40000	38000	26000	31700	23400	31700	22300	31700	21300	31200	20300
60000	57000	39000	47500	35100	47500	33500	47500	32000	46800	30400
90000	79000	58500	68900	52700	68900	50300	68600	48000	68600	45600
115000	103000	75000	100400	67500	98900	64500	83000	61500	83000	58500
127000 or 130000	116000	84500	115500	76100	111800	72700	101300	69300	100400	65900

*In the U.S.A., the input rating for altitudes above 2000 ft (610m) must be reduced by 4% for each 1000 ft (305 m) above sea level. In Canada, the input rating for altitudes from 2001 to 4500 ft (611 to 1372 m) above sea level must be derated by 10% by an authorized gas conversion station or dealer. For Canadian Installations from 2000 to 4500 ft (610–1372 m), use U.S.A. column 2001 to 3000 ft (611 to 914 m).

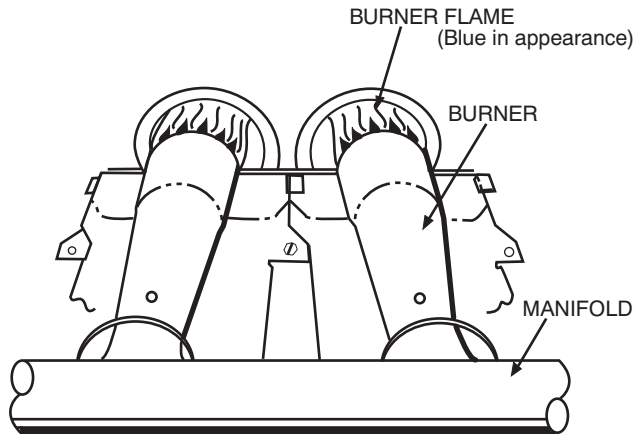

Fig. 14 - Monoport Burner

C99021

IMPORTANT: Restart unit and leak check all gas connections including the main service connection, gas valve, gas spuds, and manifold pipe plug.

38. After all leaks are eliminated, replace control access panel.

⚠ WARNING

FIRE AND EXPLOSION HAZARD

Failure to follow this warning could result in personal injury and/or property damage.

Never test for gas leaks with an open flame. Use a commercially available soap solution made specifically for the detection of leaks to check all connections. A fire or explosion could result causing property damage, personal injury and/or loss of life.

⚠ WARNING

EXPLOSION, PERSONAL INJURY HAZARD

Failure to follow this warning could result in personal injury or death.

This unit is designed to operate at a minimum 10.0 IN. W.C. of manifold pressure with propane gas. Refer to Table 8 for proper manifold pressure settings.

CPLPCONV

<p>THIS FURNACE WAS CONVERTED ON <u> </u> - <u> </u> - <u> </u> TO PROPANE GAS <small>(DAY - MONTH - YEAR)</small></p> <p>KIT NO.: CPLPCONV013C00 (0 ~ 2000 ft. (0~610m) above sea level), CPLPCONV014C00 (2001 ~ 6000 ft. (611~1829m) above sea level)</p> <p>BY:</p> <p>_____</p> <p>_____</p> <p>_____</p> <p><small>(Name and address of organization making this conversion), which accepts the responsibility that this conversion has been properly made.</small></p>	<p>CE GÉNÉRATEUR D'AIR CHAUD A ÉTÉ CONVERTI LE <u> </u> - <u> </u> - <u> </u> POUR <small>(JOUR - MOIS - ANNÉE)</small></p> <p>DE L'ENSEMBLE N°: CPLPCONV013C00 (0 ~ 2000 ft. (0~610m) above sea level), CPLPCONV014C00 (2001 ~ 6000 ft. (611~1829m) above sea level)</p> <p>PAR:</p> <p>_____</p> <p>_____</p> <p>_____</p> <p><small>(nom et adresse de l'organisme qui a effectué la conversion), qui accepte l'entière responsabilité de la conversion.</small></p> <p style="text-align: right;">48VL500384</p>
---	---

Fig. 15 - Conversion Responsibility Label

A14633

Table 8 – Propane Gas Orifice Sizes and Manifold Pressures (IN. W.C.)

PROPANE CONVERSION KIT RATING PLATE - CARRIER CORP.

THIS APPLIANCE HAS BEEN CONVERTED TO USE PROPANE GAS FOR FUEL. REFER TO KIT INSTRUCTIONS FOR CONVERSION PROCEDURES. USE PARTS SUPPLIED WITH KIT AND INSTALLED BY QUALIFIED PERSONNEL. SEE EXISTING RATING PLATE FOR APPLIANCE MODEL NO. AND INPUT RATING.

NOTE: Gas input rate on rating plate is for installations up to 2000 ft. above sea level. In U.S.A. the input rating for altitudes above 2000 ft. must be reduced by 4% for each 1000 ft. (305 m) above sea level. In Canada the input rating for altitudes from 2001 ft. to 4500 ft. (611 to 1372 m) above sea level must be derated by 10% by an authorized gas conversion station or dealer. For Canadian Installations from 2000 to 4500 ft, use U.S.A. column 2001 to 3000 ft.

KIT NO. CPLPCONV013C00 (0 ~ 2000 ft. (0 ~ 610m) above sea level)

KIT NO. CPLPCONV014C00 (2001 ~ 6000 ft. (611 ~ 1829m) above sea level)

FUEL USED: PROPANE GAS

INLET PRESSURE (min - max); 11.0 - 13.0 in. WC

APPLIANCE MODELS	NAMEPLATE INPUT, HIGH STAGE (Btu/hr)	NUMBER OF BURNERS	ALTITUDE OF INSTALLATION ABOVE SEA LEVEL, U.S.A. * †					
			0 to 2000	2001 to 3000*	3001 to 4000	4001 to 5000	5001 to 6000	
48DU, 48DT, 48VG [‡] , 48VR [‡] , 48XL, 48XT, 577B, 577D, 577E [‡] , 677B, 677D, 677E [‡]	40000	2	Orifice No. (Qty) Manifold Press. High / Low	55 (2) 10.0 / 5.0	56 (2) 11.0 / 6.0	56 (2) 11.0 / 5.5	56 (2) 11.0 / 5.0	56 (2) 10.7 / 4.8
	60000	3	Orifice No. (Qty) Manifold Press. High / Low	55 (3) 10.0 / 5.0	56 (3) 11.0 / 6.0	56 (3) 11.0 / 5.5	56 (3) 11.0 / 5.0	56 (3) 10.7 / 4.8
	90000	3	Orifice No. (Qty) Manifold Press. High / Low	53 (3) 10.0 / 5.4	54 (3) 11.0 / 6.4	54 (3) 11.0 / 5.9	54 (3) 11.0 / 5.4	54 (3) 11.0 / 5.0
	115000	3	Orifice No. (Qty) Manifold Press. High / Low	51 (3) 10.0 / 5.4	52 (3) 11.0 / 5.0	52 (3) 10.6 / 4.8	53 (3) 11.0 / 6.1	53 (3) 11.0 / 5.5
	127000 or 130000	3	Orifice No. (Qty) Manifold Press. High / Low	49 (3) 10.0 / 5.4	50 (3) 11.0 / 4.8	51 (3) 11.0 / 4.9	52 (3) 11.0 / 5.2	52 (3) 11.0 / 5.0
48ES, 48EZ, 48VG [§] , 48VL, 48VR [§] , 48VT, 574D, 577C, 577E [§] , 674,D, 677C, PY3G, PY4G	40000	2	Orifice No. (Qty) Manifold Press.	55 (2) 10.0	56 (2) 11.0	56 (2) 11.0	56 (2) 11.0	56 (2) 10.7
	60000	2	Orifice No. (Qty) Manifold Press.	53 (2) 10.0	54 (2) 11.0	54 (2) 11.0	54 (2) 11.0	54 (2) 11.0
	60000	3	Orifice No. (Qty) Manifold Press.	55 (3) 10.0	56 (3) 11.0	56 (3) 11.0	56 (3) 11.0	56 (3) 10.7
	90000	3	Orifice No. (Qty) Manifold Press.	53 (3) 10.0	54 (3) 11.0	54 (3) 11.0	54 (3) 11.0	54 (3) 11.0
	115000	3	Orifice No. (Qty) Manifold Press.	51 (3) 10.0	52 (3) 11.0	52 (3) 10.6	53 (3) 11.0	53 (3) 11.0
	127000 or 130000	3	Orifice No. (Qty) Manifold Press.	49 (3) 10.0	50 (3) 11.0	51 (3) 11.0	52 (3) 11.0	52 (3) 11.0

‡ 208/230 VAC Models only

§ 460 VAC Models Only

48VL500383

A14634

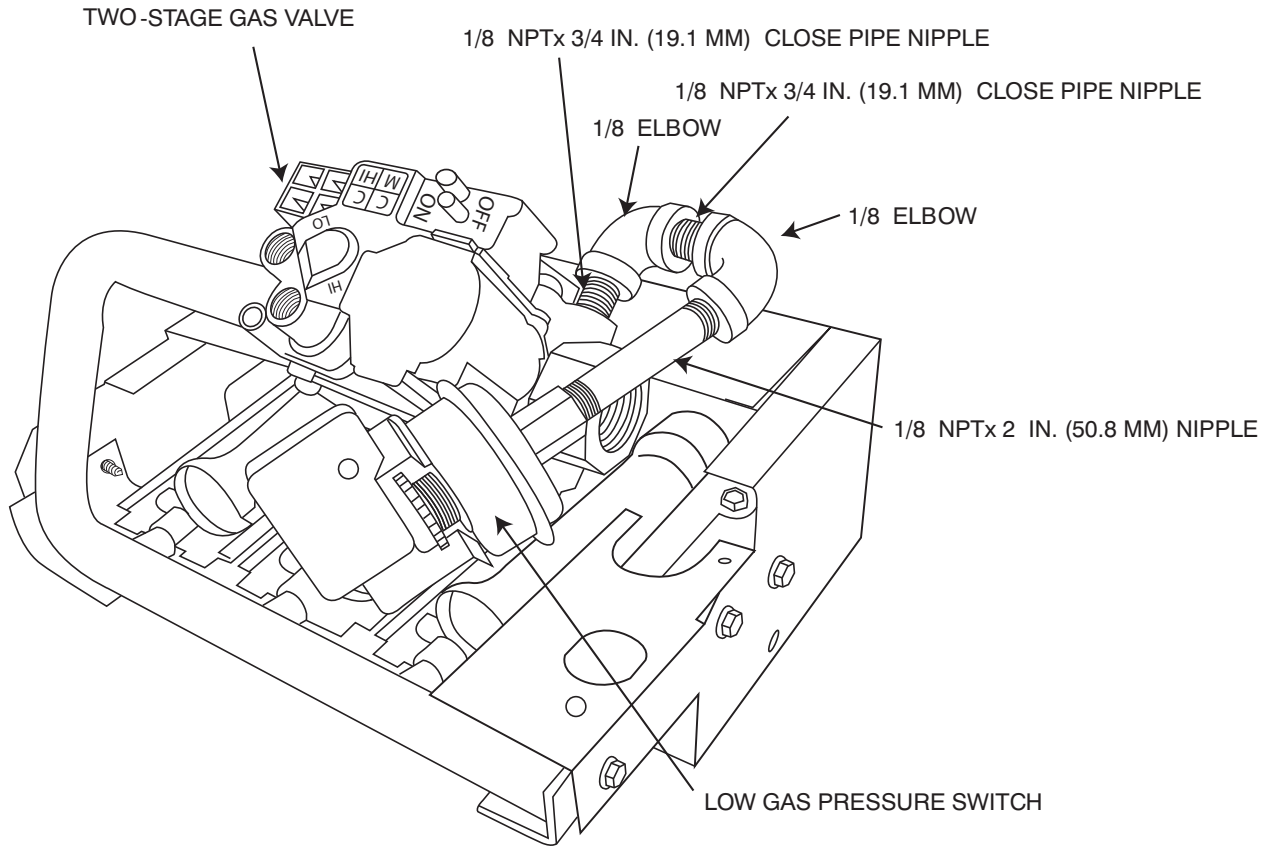

A09016

Fig. 16 - Installing Elbows, Nipples, and Pressure Switch on Two-Stage Units