



Carrier Connect™ Wi-Fi Thermostat 33CONNECTSTAT43 Installation Guide





Verify that you have the most current version of this document from www.hvacpartners.com or www.accounts.ivusystems.com or your local Carrier office.

Important changes are listed in **Document revision history** at the end of this document.

CARRIER CORPORATION ©2021. All rights reserved throughout the world. i-Vu is a registered trademark of Carrier Corporation. All other trademarks are the property of their respective owners.



Contents

What is the Carrier Connect™ Wi-Fi Thermostat?	1
Specifications	1
Wiring the Carrier® Connect™ Wi-Fi Thermostat	2
To wire the thermostat to equipment.....	2
To wire and mount the thermostat	4
To connect a remote input (sensor or contacts)	6
To wire for BACnet communication	8
Registering and setting up a mobile device for enhanced access	9
Using the Connect website or app	10
Configuring the system	13
To configure advanced SYSTEM SETTINGS.....	14
Operating your system using the Carrier® Connect™ Wi-Fi Thermostat	22
Occupancy.....	22
Supply fan	22
Cooling.....	23
Econ enable	23
Heating	23
Dehumidification	24
Humidification	25
Filter status	25
Holidays.....	25
BACnet integration	25
Using the Carrier® Connect™ Wi-Fi Thermostat's screens	26
HOME	26
SETPOINT	27
MODE	28
SETTINGS	28
HUMIDITY	28
FAN.....	30
PROGRAM.....	30
HOLIDAY	31
BANNER.....	31
DATE and TIME	31
SOFTWARE screen and BACKLIGHT screen	32
ADVANCED.....	32
FILTER.....	33
LOCKOUT	33
CLEAN	33
LOG.....	34
STATUS	34
SERVICE.....	34
Installation test	35
Troubleshooting	36
Outputs based on demand and configuration	36
Fault definitions	37
Recovering from a power outage	38
Resetting wi-fi access	39
Compliance.....	40
FCC Compliance	40
BACnet Compliance.....	40

Appendix: BACnet Points List	41
Document revision history	46



What is the Carrier Connect™ Wi-Fi Thermostat?

The Carrier® Connect™ Wi-Fi Thermostat (Part #33CONNECTSTAT43) is a thermistor-based wireless thermostat that can sense a 10K Type II OAT or a remote space or return air sensor and can control up to 4 heating and 3 cooling stages.

The Carrier® Connect™ Wi-Fi Thermostat package includes:

- Thermostat
- Mounting Hardware - two screws with drywall anchors and one security screw
- Quick Start Guide - Catalog No. 11-808-729-01

Some of the features:

- Supporting standard air conditioning and heat pump rooftop and split units
- 7-day scheduling with up to 4 periods per day
- Holiday scheduling
- Full-color touchscreen that's easy to navigate
- Remote programming and monitoring using secure Apple® or Android® mobile app or Web portal
- Text and email service alerts
- Automatic software updates via Wi-Fi

Specifications

Power requirements	24 Vac +/- 10% @ 3VA
Network Requirements	Wi-Fi connectivity supports Wi-Fi: 802.11 a/b/g/n standards on 2.4 GHz networks
Environmental operating range	32° to 104° F (0° to 40° C), 10 to 95% relative humidity, non condensing
Mounting	Standard 4 x 2 in. electrical box using the 6-32 x 1/2 in. mounting screws provided
Overall dimensions	Width: 5.13 in. (13 cm) Height: 3.23 in. (8.2 cm) Depth: 0.94 in. (2.4 cm)
BACnet Support	Conforms to the BACnet Application Specific Controller (B-ASC) Device Profile as defined in ANSI/ ASHRAE Standard 135-2012 (BACnet) Annex L, Protocol Revision 14
Listed by	FCC Part 15, Subpart J compliant

Wiring the Carrier® Connect™ Wi-Fi Thermostat

To wire the thermostat to equipment

Packaged Rooftop Units

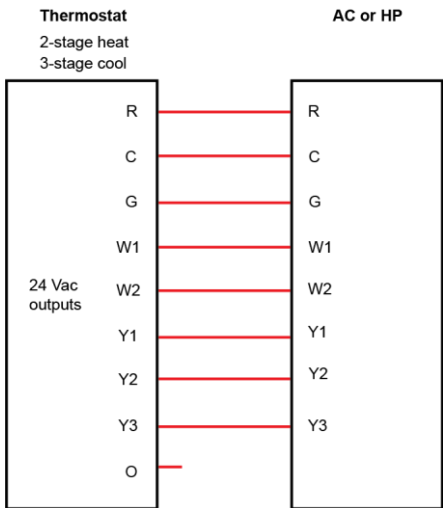

Hydronic Fan Coil

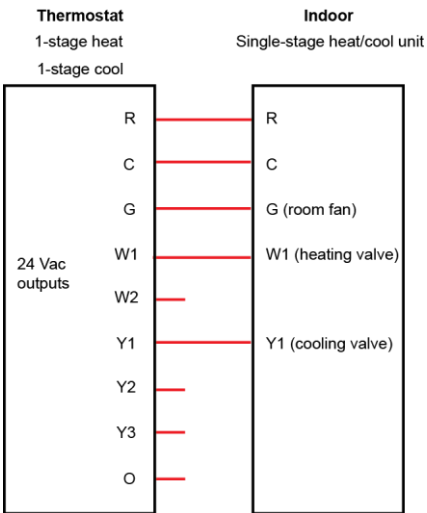

Dual fuel systems (Furnace & heat pumps)

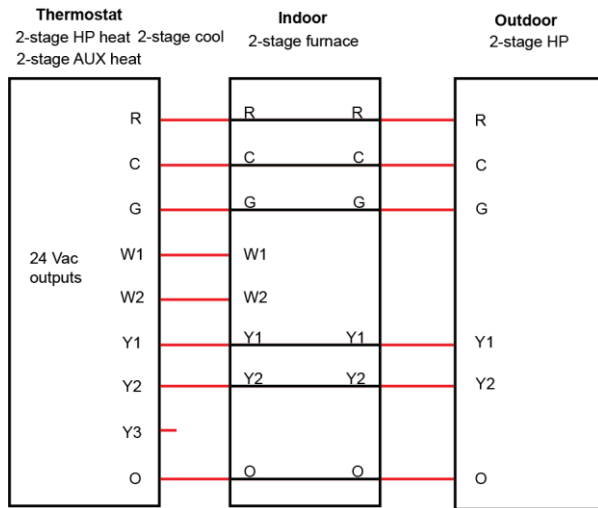

Furnace/AC System

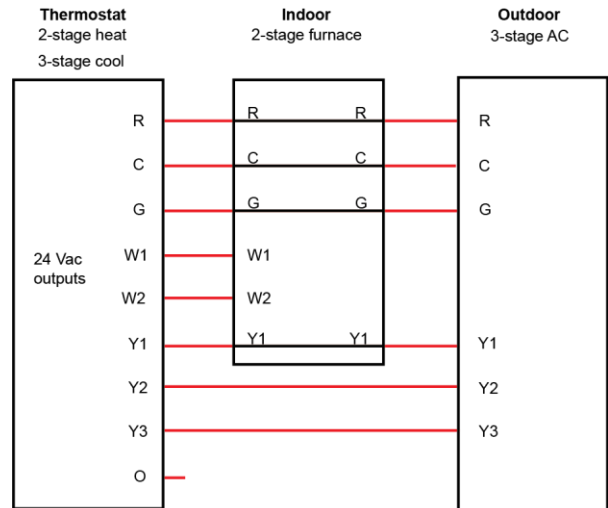

Water Source Heat Pump

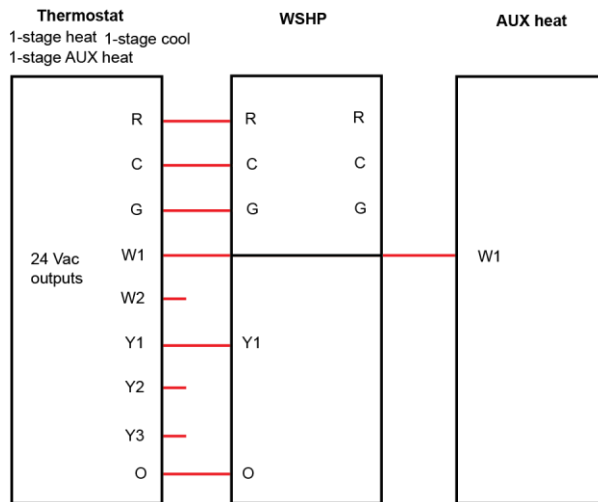

Air Handler or DX Fan Coil/AC Split System

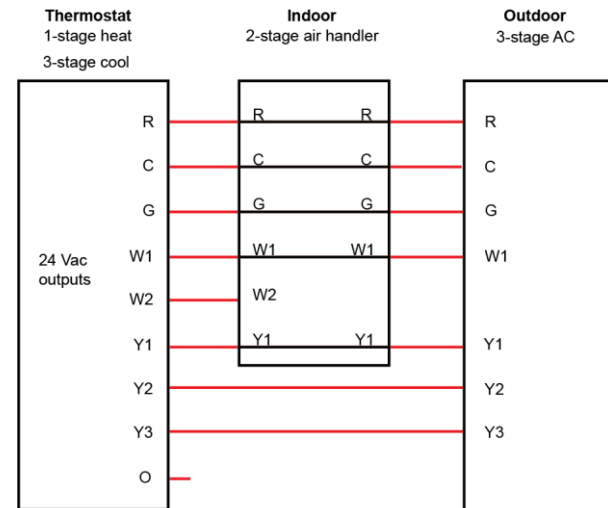

Air Handler or DX Coil/Heat Pump split system

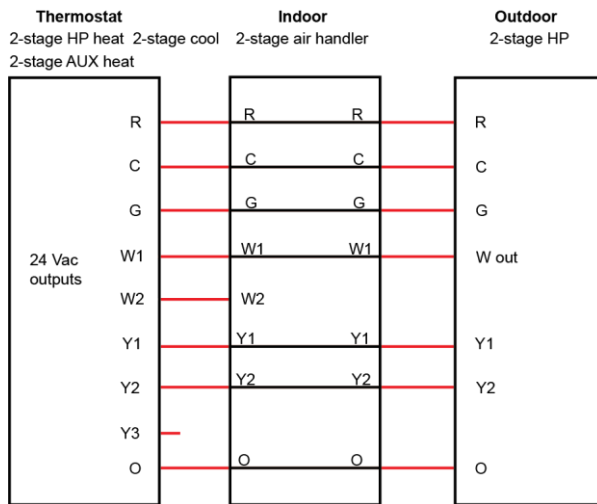

To wire and mount the thermostat

- 1 Turn off 24 Vac power at the equipment circuit breaker or the system switch.
- 2 Place the thermostat base against your wall to mark drill holes.
- 3 Drill the anchor holes or use existing holes to mount the wallplate.
 - o Drywall – Drill 3/16 in. hole for the anchor.
 - o Plaster – Drill 7/32 in. hole for the anchor.
- 4 Pull wires through opening in base.

- Attach the base to the wall with the provided screws.

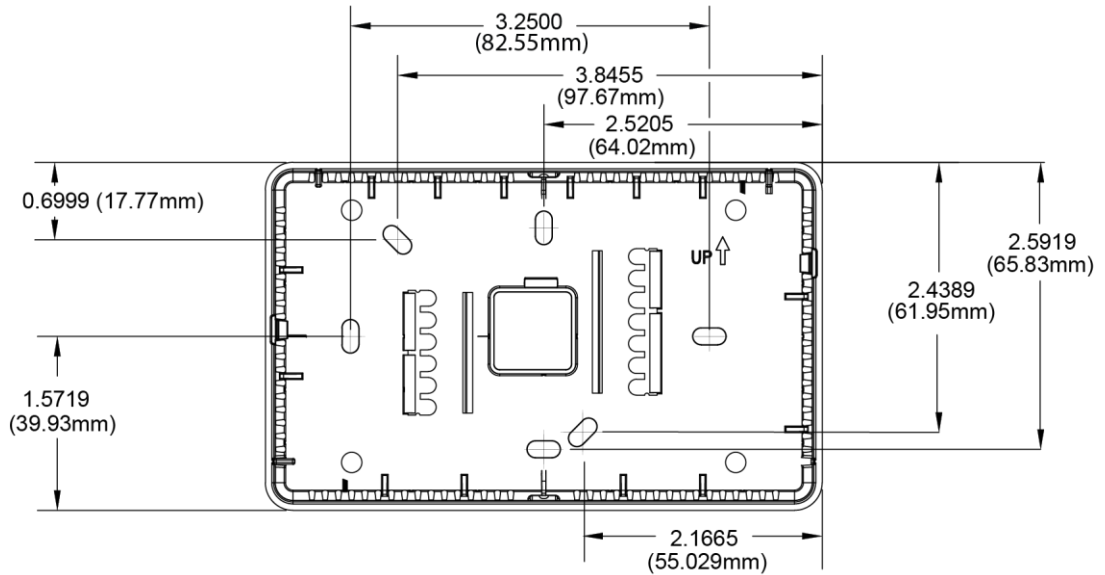

- Straighten the wires and match your wire configuration to the terminals on the base.
- Connect each wire individually by pushing down on the quick connect tab, inserting it into the connector opening, and then releasing the tab.

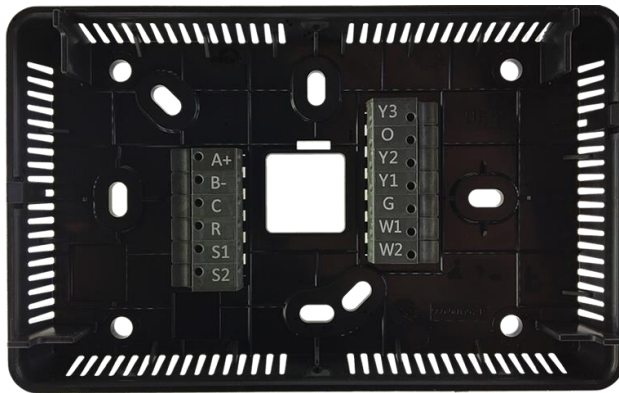

- 8 Attach the thermostat face by aligning it with the hinge guide on top of the back.



- 9 Turn on the 24 Vac power. The thermostat displays the **HOME** screen. See *HOME* (page 26) for details.

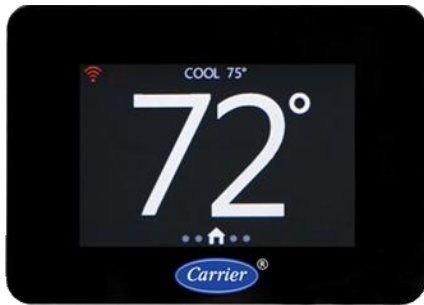

- 10 Configure your system as described in this document.

To connect a remote input (sensor or contacts)

NOTE Use the specified type of wire and cable for maximum signal integrity.

Power	N/A
Description	Stranded, twisted pair
Conductor	If < 100 ft (30.5 meters) 22 AWG, unshielded If > 100 ft (30.5 meters) 22 AWG, shielded
Maximum length	500 feet (152 meters)
Insulation	Plenum rated
Thermistor	10K Type II (CP/MCI)

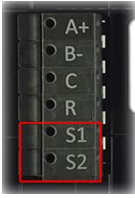

Use Remote Sensor input terminals S1 and S2 for the following inputs:

- OAT
- T55
- SAT
- Occupancy contacts
- Econ Fault

Wiring for space temperature sensor averaging

4 sensors

Connect
Thermostat

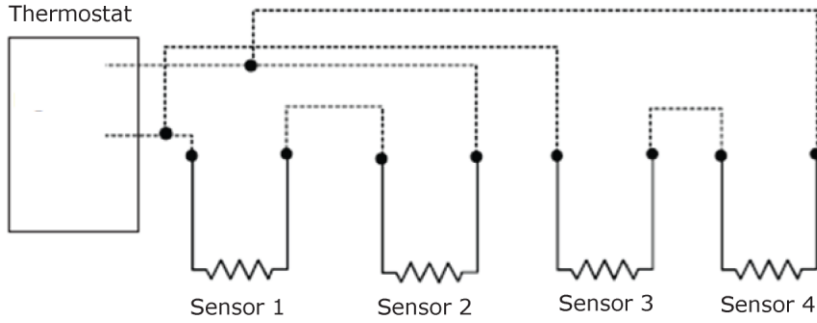

9 sensors

Connect
Thermostat

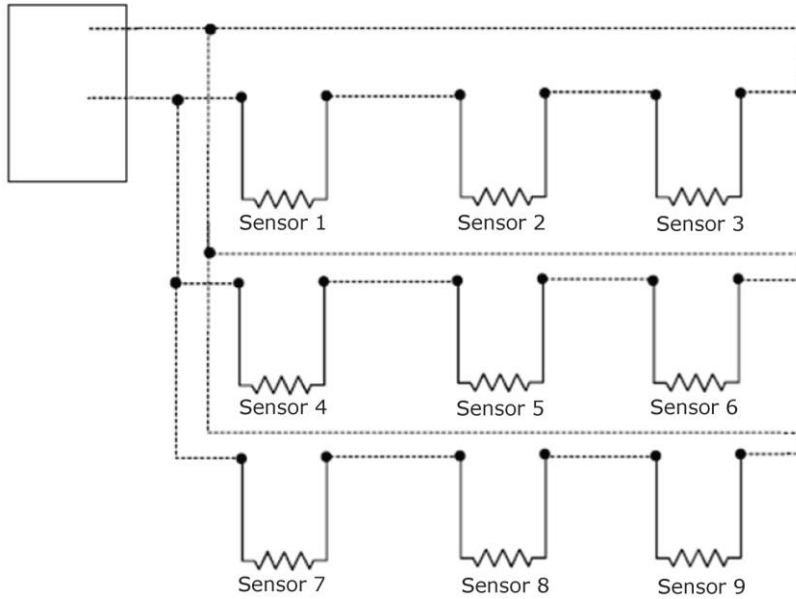

To wire for BACnet communication

NOTE Use the specified type of wire and cable for maximum signal integrity.

Cable	22 or 24 AWG, low-capacitance, twisted, stranded, shielded copper wire
Maximum length	2000 feet (610 meters) per segment
Baud rate	9600 bps, 19.2 kbps, 38.4 kbps, or 76.8 kbps, 115.2 kbps

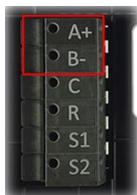

Connect communication wiring to terminals **A+** and **B-**. Do not terminate shield at the thermostat.

CAUTION Maintain the same polarity.

NOTE For more networking details, see the *Open Controller Network Wiring Installation Guide*.

Registering and setting up a mobile device for enhanced access

Downloading the Connect™ App provides enhanced access to your device. The Connect™ App is available for Apple iOS® at App Store® or at Google Play® for Android devices. Search for **Carrier Connect™ Thermostat**.

NOTE Device compatibility: Apple IOS® 7.0 or later or Android 4.2 or later

- 1 After downloading Connect™ App, select **USER SETUP** and **Register New Account**.

NOTE You can also register new accounts using the website connectstat.carrier.com.

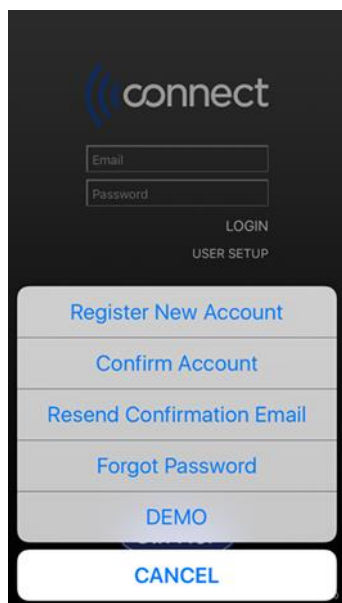

- 2 Enter an email address that you can access on your mobile device and receive the confirmation email to complete the registration process.
- 3 Select **SETUP NEW THERMOSTAT** and follow the Connect™ App instructions.

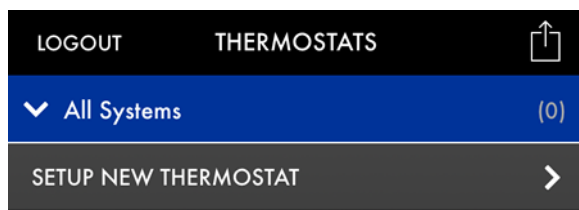

- 4 After registering the thermostat, enter servicing contractor's name and phone number on the **SERVICE INFO** screen.
- 5 On the **THERMOSTATS** screen, select the thermostat from list and the mobile app's **HOME** screen appears.



Using the Connect website or app

After you register for an account, you can access the thermostat by using the app directly or through the Web at connectstat.carrier.com.

You can:

- Monitor the thermostat operation
- Set up occupied and unoccupied (holiday) schedules
- Adjust setpoints
- Share thermostat access with other users
- Create groups of thermostats that you have registered
- Create groups of thermostats that other owners have shared with you
- Get online product information
- Find local dealer support

To navigate

- On a touchscreen device, use any of the following:
 - swipe the screen
 - tap the arrow on the side
 - tap a dot on the bottom of the screen on either side of the HOME button
 - On a non-touchscreen device, click on the gray arrow  on either the side of the screen.
 - You can press or click  to access the following drop-down list:
 - **My Systems**
 - **My Account**
 - **Shared Systems**
 - **Product Information**
 - **Find and Expert**
 - **Logout**
- 1 After logging in, a list appears of thermostats that you have registered and that have been shared with you.
 - 2 Click .

3 Swipe or click to navigate to the **SETTINGS** screen.

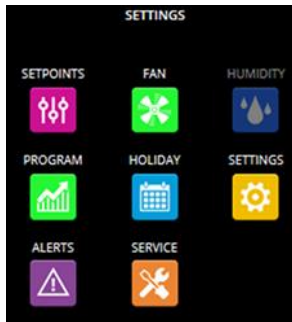

NOTES

- Navigate by clicking or pressing the buttons such as **SETPOINTS, FAN, PROGRAM**, etc..
- Grayed out function buttons indicate that feature is not being used on the thermostat.

Screens	Use to...
SETPOINTS	Adjust the occupied and unoccupied setpoints by selecting each temperature.
FAN	View and modify fan settings. <ul style="list-style-type: none"> ● The default setting for fan operation is AUTO for both Occupied and Unoccupied periods. When operating in AUTO MODE, the fan only runs when there is an active heating or cooling demand. ● When you select ON, the fan runs continuously, except during the Blower On Delay when a heat cycle is starting. There is a 30-second minimum on/off timer when changing the FAN MODE.
NOTE The following selections are not available if the thermostat has been configured for non-programmable operation.	
HUMIDITY	Adjust the thermostat's humidify and dehumidify setpoints.
PROGRAM	You can: <ul style="list-style-type: none"> ● Set Occupied and Unoccupied start times, depending on the configured number of periods and the user's security level. ● Select the time at the bottom of the screen to adjust the start or stop time of each period in 15 minute increments. ● Select Copy to apply that schedule to other days of the week. ● Adjust the setpoints for each period.

Screens	Use to...
HOLIDAY	<p>Set HOLIDAY (same as unoccupied) periods with the following options:</p> <ul style="list-style-type: none">• Length of time from 1 to 365 days• Same day of each week of the month• Specific day of specific week(s) of the month <p>NOTE Requires advanced security level to edit these settings</p> <ul style="list-style-type: none">• Select +ADD HOLIDAY to add start month, day, and number of days.• Select ADVANCED to configure same day of each week(s) of that month.• To delete a holiday on the:<ul style="list-style-type: none">○ Mobile app - swipe the selected holiday to the left and select Delete○ Web app - select x on right side of the holiday
SETTINGS	<p>Enter the name and location of the thermostat for the user's reference. The user can enter an email address for alerts and a mobile phone number to receive text alert messages.</p> <p>NOTE Requires advanced security level to edit these settings.</p>
ALERTS	<p>Displays a list of alerts that have been flagged in the thermostat.</p>
SERVICE	<p>Displays the name and phone number of the service company or individual who is responsible for servicing the system.</p> <p>NOTE Requires advanced security level to edit these settings.</p>

Configuring the system

- 1 On the thermostat, not a mobile device, swipe the **HOME** screen twice to the left to navigate to the **MODE** screen and ensure the **MODE** is **OFF**.

NOTE The yellow line above a button indicates the current **MODE**.



- 2 Swipe to go to the **FAN** screen and then press and hold the **Fan Button**  for 5 seconds to get to the **SYSTEM SETTINGS** screen.

NOTE You can **ONLY** access the **SYSTEM SETTINGS** screens from the thermostat itself, not the app or web.

- 3 Enter the 3-digit security PIN code, if applicable, to open the **SYSTEM SETTINGS** screen.



- 4 Use the advanced options on the **SYSTEM SETTINGS** screens to configure and setup your system, change, and view options.

NOTES

- The yellow **Row Indicator** at the right side of the screen indicates the current location in the list of advanced settings options. Swipe up or down to navigate through options and then tap to select one.
- Swipe on any of the **SYSTEM SETTINGS** sub-screens to return to the **SYSTEM SETTINGS** main screen.

To configure advanced SYSTEM SETTINGS

You can only adjust the **SYSTEM SETTINGS** screens and parameters on the thermostat itself. You cannot access them on a mobile device.

You can select **FACTORY DEFAULTS** to restore all default settings to the original values.

Parameter Name/Description	Default and Range
HEAT EQUIP TYPE — The equipment heating type. If you select GAS HEAT and the COMPRESSOR TYPE for HP , then the defined DUAL FUEL thermostat operation is used for heating.	D: GAS HEAT R: GAS HEAT/ELECTRIC
HEATING EQUIP STAGES — The number of gas heating stages or E- heating stages in the equipment NOTE If set to 2, the W2 relay output is not available for optional functions, such as <ul style="list-style-type: none"> ○ Humidifier ○ Humid-MiZer™ dehumidification ○ Occupancy Output 	D: 1 R: 1 to 2
COMPRESSOR TYPE — The type of the unit's compressors(s) NOTE Select HP for the HEAT EQUIP TYPE to define the auxiliary heat type.	D: A/C R: NONE, A/C, HP
COMPRESSOR STAGES — The numbers of compressors NOTES <ul style="list-style-type: none"> • If COMPRESSOR TYPE is set to HP, the number of stages also defines the number of HP heating stages. • If set to 3, the Y3 relay output is used for the third-stage compressor and the thermostat configuration is limited for the following: <ul style="list-style-type: none"> ○ Humidifier ○ Humid-MiZer™ dehumidification ○ Occupancy output 	D: 2 R: NONE, 1 to 3
AUTO ALLOWED — Enables and disables the thermostat to automatically switch from heating to cooling to maintain the temperature between the setpoints.	D: YES R: YES/NO
PROG OR NON-PROG — Allows the thermostat to operate as a non-programmable (simplified) thermostat or a programmable thermostat with two or four time periods per day.	D: PROG R: PROG / NON-PROG
MAX HOLD TIME — The thermostat setpoints cannot be overridden by the user. When the SCHEDULE PAUSED button is pressed on the SETPOINTS screen (SCHEDULE IS RUNNING), and the user changes the setpoint, the MAXIMUM TEMPORARY HOLD TIMER is started with this value and displayed in the clock location.	D: 2 hours R: OFF 1 - 6 hours
FAHRENHEIT OR CELSIUS — The temperature scale	D: °F R: °F/°C

Parameter Name/Description	Default and Range
<p>SMART RECOVERY – Transitions the conditioned space from one programmable temperature period to the next with 1°F increments of the heating setpoint or with 1°F decrements of the cooling setpoint, so that by the time the next period starts, the setpoints are at the desired temperature. The purpose of the gradual transition is to use less energy by preventing staging up (because of a higher demand) to higher stages. The transitions occur in a linear fashion over the smart recovery time period.</p> <ul style="list-style-type: none"> • If you start a temporary hold in the middle of a smart recovery, the setpoints of the temporary hold are used. • If a temporary hold is already active during the time that smart recovery would have been started, a smart recovery does not start. • If the temporary hold ends in the middle of what would have been a smart recovery, the smart recovery starts where it would have been in the linear progression at the same time as when the temporary hold was not active. 	<p>D: 30</p> <p>R: NO, 30, 60, 90 MIN</p>
<p>FAN ON WITH W – Supplies a fan output demand as soon as a W1 or W2 output demand is active.</p>	<p>D: YES</p> <p>R: YES/NO</p>
<p>REVERSING VALVE – Defines whether the ON state of the reversing valve is used for heating or cooling when COMPRESSOR TYPE is set to HP.</p> <ul style="list-style-type: none"> • When the ON state of the reversing valve is used for cooling, the signal is typically referred to as a O. • When the ON state of the reversing valve is used for heating, the signal is typically referred to as a B demand. • If COMPRESSOR TYPE is set to HP, the thermostat configuration may be limited for the following: <ul style="list-style-type: none"> • Humid-MiZer™ dehumidification • Humidifier operation • Occupancy output 	<p>D: COOL</p> <p>R: COOL/HEAT</p>
<p>SPACE TEMP OFFSET – Calibrates the internal space temperature sensor.</p>	<p>D: 0°F</p> <p>R: -5 to 5°F</p>
<p>SPACE HUM OFFSET – Calibrates the internal relative humidity sensor.</p>	<p>D: 0%</p> <p>R: -9 to 9%</p>
<p>AUTO CHANGEOVER – The minimum time between switching from heat-to-cool or from cool-to-heat demands, when in AUTO MODE. The timer begins when the MINIMUM OFF TIMER expires.</p>	<p>D: 30 MIN</p> <p>R: 5, 10, 15, 20, 25, 30 MIN</p>

Parameter Name/Description	Default and Range
<p>REMOTE SENSOR – Determines whether the remote sensor hardware input is:</p> <ul style="list-style-type: none"> • NONE – Not used • NONE or SPACE – The outdoor temperature is acquired by Wi-Fi through the server, based on the location of the mobile device used to connect the thermostat to a router, or based on the ISP location, if a computer connects the thermostat to a router. • OUTDOOR – Senses the outdoor temperature NOTE The outdoor temperature is not available if the thermostat is not connected to Wi-Fi or if you do not select OUTDOOR. • AVERAGE – Space temperature results from averaging the internal and the external sensor • OCCUPANCY – An external source is accessed to determine if the setpoints are Occupied or Unoccupied. When Normally Open contacts close, the Occupied setpoints are used. NOTE When selected, NON-PROG is automatically set and is not displayed in the Installer Settings until this parameter is changed. • FAULT INPUT – An external source is used to detect a fault, as determined by the attached Economizer. • SAT – A sensor to provide a means of monitoring supply air temperature NOTE SAT is a monitor-only point and has no effect on unit operation. 	<p>D: NONE</p> <p>R: NONE SPACE OUTDOOR AVERAGE OCCUPANCY FAULT INPUT SAT</p>
<p>SAT TEMP OFFSET – Allows temperature offsets from -5° to 5°.</p> <p>NOTE Only available when Remote Sensor Input > SAT is enabled.</p>	<p>D: 0°F</p> <p>R: -5 to 5°F (1° increments)</p>
<p>MAX SETPOINT ERROR – Allows a temperature deviation from setpoint of between 2 and 30°, to determine fault conditions (ID TEMP RANGE HIGH or LOW).</p> <p>NOTE This value is added to the cooling setpoint or subtracted from the heating setpoint.</p>	<p>D: 10°F</p> <p>R: 2 to 30°F (1° increments)</p>
<p>ID TEMP FLT INHIBIT – Allows a time delay applied to the ID TEMP fault. The range is adjustable from 10 to 240 minutes (60 default).</p> <p>NOTE Allow for recovery time when transitioning from unoccupied to occupied periods.</p>	<p>D: 60 mins</p> <p>R: 10 to 240 mins (10 min increments)</p>
<p>COOL LOCKOUT – Delays the cooling equipment demands if the outdoor air temperature is below the selected value. There is a SYSTEM EVENT warning if the mode and space temperature dictate that there should be a cooling demand and the outdoor temperature is preventing this demand.</p>	<p>D: 55°F</p> <p>R: OFF 0 to 80°F (5°F increments)</p>
<p>LOW COOL LOCKOUT – (Heat pump operation only) Enables the thermostat to start all cooling stages on a demand for cooling based on the configured value. Normal cooling always starts with first stage compressor (Y1) and stages up to the second (Y2), when the demand is sufficient and staging and cycle timer constraints are satisfied.</p> <p>If the outdoor temperature is equal to or greater than the configured value of 80 to 110°F, all stages of cooling are energized. If set to ON, all stages are energized on a call for cooling. The outdoor temperature must also be greater than the COOL LOCKOUT value. When a cooling cycle starts under a high cool latch, it finishes the cooling cycle on HIGH STAGE. If the cooling equipment is energized to satisfy a dehumidify demand only (no cooling demand), the latch is not applied.</p>	<p>D: OFF</p> <p>R: OFF 80 to 110°F (5°F increments) ON</p>

Parameter Name/Description	Default and Range
<p>LOW HEAT LOCKOUT – (Heat Pump operation only) Enables the thermostat to start all compressor heating stages on a demand for heating, based on the configured value. When the COMPRESSOR TYPE is set to HP and compressor heat is requested, it always starts with the first compressor stage (Y1) and stages up to second stage (Y1 and Y2) when the demand is sufficient and staging and cycle timer constraints have been satisfied.</p> <p>If the outdoor temperature is equal to or less than the configured value of 20 to 50 °F, both the first and second stages of the compressor are energized to satisfy all heat pump heating demands. If set to ON, both compressors are energized on a call for heating. The outdoor temperature must also be greater than the HP LOCKOUT value. When a cycle starts under a high heat latch, it finishes the heating cycle on HIGH STAGE.</p>	<p>D: OFF</p> <p>R: 20 to 50 °F (5 °F increments) ON</p>
<p>TIME BETWEEN FUEL TYPES – The minimum time limit between switching from one fuel type to another (other staging rules may also be in effect). Use only if the COMPRESSOR TYPE is set for HP.</p>	<p>D: 15 MIN</p> <p>R: 10, 15, 20, 25 MIN</p>
<p>CYCLE TIMER – The maximum number of heat cycles per hour</p>	<p>D: 4</p> <p>R: 2, 4, 6, 8</p>
<p>HUMIDIFIER – The output relay enables a field-installed humidifier. The humidifier is on if there is humidity demand and any heating equipment is on. If set to YES, the thermostat cannot be configured for Humidi-MiZer™ or Dehumidification. See HUM/DEHUM OUTPUT in this table for output relay details.</p>	<p>D: NO</p> <p>R: YES/NO</p>
<p>DEHUMIDIFIER – Sets the output relay to enable a factory-installed Humidi-MiZer™ for dehumidification or to use the first stage of cooling.</p> <ul style="list-style-type: none"> If HUMDIMIZER, the output relay energizes the Humidi-MiZer™ on the Carrier unit. If YES, the Y1 relay is energized. A new space temp setpoint is calculated to force cooling operation. <p>NOTE For details about this calculation, see <i>HUMIDITY</i> (page 28).</p> <ul style="list-style-type: none"> If OVRCL(2), it uses the first stage of cooling to satisfy a dehumidification demand, but will not overcool the space by more than 2 °F. If dehumidification is configured, the thermostat cannot also be configured for a humidifier. Additional optional functions may be limited, based on the flex outputs available. 	<p>D: NO</p> <p>R: NO YES OVRCL(2) HUMDIMIZER</p>
<p>MAX HEAT SETPOINT – The maximum heating setpoint available on the Heat Setpoint Wheel and the maximum heating setpoint that can be used during the occupied program schedule</p>	<p>D: 88 °F</p> <p>R: 50 °F to 88 °F</p>
<p>MIN COOL SETPOINT – The minimum cooling setpoint that is available on the Cool Setpoint Wheel and the minimum cooling setpoint that can be used during the occupied program schedule</p>	<p>D: 52 °F</p> <p>R: 52 to 90 °F</p>
<p>AUX HEAT LOCKOUT – The outdoor temperature value that lockouts the auxiliary heat. If the AUX HEAT LOCKOUT temperature setting is not OFF, and the outdoor air temperature is greater than AUX HEAT LOCKOUT value, then the Aux Heat (W1 and W2) outputs are not energized. Once the output is energized, it remains energized until the demand algorithm no longer requires the capacity of the auxiliary heat, regardless of the value of the outdoor air temperature.</p> <p>NOTE If the MODE is emergency heat (E-HEAT), the auxiliary heat is allowed to be energized regardless of the outdoor temperature.</p>	<p>D: OFF</p> <p>R: OFF 5 to 55 °F (5 °F increments)</p>

Parameter Name/Description	Default and Range
<p>HP LOCKOUT – If you select OFF, the heating equipment cycle always starts with the heat pump, regardless of the outdoor air temperature.</p> <ul style="list-style-type: none"> If you select a lockout temperature and the outdoor air temperature is less than the selected temperature, the heating cycle is started with the AUX HEAT source. If the outdoor air temperature is equal to or greater than the selected temperature, the heating cycle is started with the heat pump. If the outdoor temperature is not available, all heating cycles start with compressor heat. Once the heat pump is energized, it remains energized until the heating demand no longer requires heat pump heating, regardless of the outdoor air temperature. When the heat pump is not energized, but there is sufficient demand to request heat pump heating, the heat pump lockout temperature is checked against the outdoor air temperature, and if the outdoor air temperature is greater than the heat pump lockout temperature, the heat pump is energized. 	<p>D: OFF</p> <p>R: OFF 5 to 55°F (5°F increments)</p>
<p>STAGE DELAY – The minimum amount of time the current stage must be energized before staging up to the next stage of capacity.</p> <p>NOTE If the system demand is greater than 3°F, then this configuration is ignored for the current heating or cooling cycle because the staging timers are canceled to allow full equipment capacity to meet the large demand.</p>	<p>D: 10 MIN</p> <p>R: 2 MIN to 15 MIN</p>
<p>FORCED STAGE UP – The amount of time another stage of heat or cool is enabled if the space temperature conditions are not improving. If the time in a current demanded stage reaches the selected forced stage-up time, the thermostat stages up to the next available stage of capacity, even if DIFFERENTIAL demand is not met.</p>	<p>D: 30 MIN</p> <p>R: OFF 10 MIN to 120 MIN (10 minute increments)</p>
<p>DIFFERENTIAL – The required difference between the current space temperature and the setpoint, before demand is initiated. This value is additive for each new stage of equipment being demanded.</p> <p>EXAMPLE A chosen DIFFERENTIAL value of 0.5°F requires 0.5°F difference between setpoint and space temperature before first stage is turned on. Then, 1°F of difference between setpoint and space temperature is necessary before the second stage is turned on.</p>	<p>D: 1.0°F</p> <p>R: 0.3 to 2.0°F (0.1°F increments)</p>
<p>AIR FILTER REMINDER – The number of hours before a SYSTEM EVENT reminds the occupant to change the indoor air filter.</p> <ul style="list-style-type: none"> If set to OFF, a SYSTEM EVENT will not occur to remind the homeowner to change the indoor air filter. Decrements to the timer happen each hour of total equipment runtime. Minutes are not stored in non-volatile memory, so a power reset clears out the minutes within each hour of run time. Once the number of hours is initially set or later changed, the filter timer must be reset on the SETTINGS screen. 	<p>D: 3000 HRS</p> <p>R: OFF 500 HRS to 15000 HRS (500 hour increments)</p>
<p>OCCUPANCY OUTPUT – When set to ON-Y3, ON-O/B, or ON-W2, selected relay output equals current Occupancy state. Can be used for ECON Enable.</p> <p>NOTE The OCCUPANCY OUTPUT option is not displayed or available if Y3, O, and W2 relays are being used; i.e. Humidification/ Heat Pump/ 3-stage cooling/ etc..</p>	<p>D: OFF</p> <p>R: OFF ON-Y3 ON-W2 ON-O/B</p>

Parameter Name/Description	Default and Range
OCCUPANCY INPUT – This setting changes the current heating and cooling setpoints to the option selected for MAX HOLD TIME . This occurs when the short is detected on the Remote Space Sensor for the duration of 2 to 5 seconds.	D: Occupied R: Occupied Unoccupied
HUM OUTPUT – Select which output to use for humidifier. NOTE Only unassigned outputs are available.	D: OFF R: ON-Y3 ON-O/B ON-W2
DEHUM OUTPUT – Select the unassigned output to use for dehumidifier (Humidi-MiZer™). NOTE Only unassigned outputs are available.	OFF ON-Y3 ON-O/B ON-W2
LINE FREQUENCY – Used to increment operational timers within the thermostat to ensure timing accuracy.	D: 60HZ R: 50HZ 60HZ
DEALER NAME – (Optional) This setting identifies the name of the installing contractor and could be carried forward from the sensor if input through the local display.	
DEALER PHONE – (Optional) This setting identifies the phone number of the installing contractor and can be carried forward from the sensor if input through the local display.	
MSTP MAX MASTERS – Used to identify max number of masters for token passing on the MS/TP network.	D: 127 R: 1 to 127
MSTP BAUD RATE – The protocol's baud rate (communication speed) on the MS/TP network. The baud rate must be the same for all controllers on the network.	D: 76800 R: 9600 19200 38400 76800 115000
MSTP MAC ADDRESS – Unique identifier for this thermostat on the MSTP network	D: 1 R: 1 TO 127
BACNET UTC OFFSET – Offset applied to UTC time	D: 5 hrs / 0 min R: -13 to 13 hrs / 0 min
DEVICE ID – Unique identifier for this thermostat within the system	D: 0 R: 1 TO 4194302
DEVICE OBJECT NAME – Assign an alpha-numeric string that is unique to the system.	(Name)
DEVICE LOCATION – (Optional) Use to provide details about thermostat location.	(Location)
DEVICE DESCRIPTION – (Optional) Use to provide additional details about this thermostat.	(Description)

Parameter Name/Description	Default and Range
<p>BACNET BMS OCC – Use to enable or disable BACnet occupancy control.</p> <p>NOTE Occupancy is determined by 1 of 3 methods. You cannot have BACNET BMS OCC with both PROGRAMMABLE MODE and REMOTE SENSOR set to OCCUPANCY. Setting BACNET BMS OCC to YES forces PROG OR NON-PROG to NON-PROG and switches REMOTE SENSOR to NONE if set to OCCUPANCY.</p>	<p>D: NO</p> <p>R: YES NO</p>
<p>BACNET CONFIG WRITE – If YES, allows BACnet to write to GATED_WRITE points. See Appendix BACnet Points List.</p>	<p>D: NO</p> <p>R: NO YES</p>
<p>NET GP OUT TIMEOUT – Used to timeout Network General Purpose Outputs.</p> <p>NOTES</p> <ul style="list-style-type: none"> Sets the maximum time to lapse between writes to the present_value property of the output object before it returns to INACTIVE. Accessible only if Y3, W2, or O/B output is available as a GP OUTPUT. 	<p>D: 2 MIN</p> <p>R: 2 MIN 20 MIN 1 HR UNLIMITED</p>
<p>NET GP Y3 MODE – Controls the Y3 output over the BACnet network.</p> <ul style="list-style-type: none"> DISABLED sets the Present_Value of the BACnet object to INACTIVE and READ_ONLY and the corresponding output relay will be in a de-energized state Selecting ENERGIZE ACTIVE allows BACnet writes and energizes the output relay when the Present_Value is ACTIVE. Selecting ENERGIZE INACTIVE allows BACnet writes and will energize the output relay when the Present_Value is INACTIVE. 	<p>D: DISABLED</p> <p>R: DISABLED ENERGIZED ACTIVE ENERGIZED INACTIVE</p>
<p>NET GP W2 MODE – Controls the W2 output over the BACnet network.</p> <ul style="list-style-type: none"> DISABLED sets the Present_Value of the BACnet object to inactive and read-only and the corresponding output relay will be in a de-energized state. ENERGIZED ACTIVE allows BACnet writes and energizes the output relay when the Present_Value is ACTIVE. ENERGIZED INACTIVE allows BACnet writes and energizes the output relay when the Present_Value is INACTIVE. 	<p>D: DISABLED</p> <p>R: DISABLED ENERGIZED ACTIVE ENERGIZED INACTIVE</p>
<p>NET GP OB MODE – Controls the O/B output over the BACnet network.</p> <ul style="list-style-type: none"> DISABLED sets the Present_Value of the BACnet object to inactive and read-only and the corresponding output relay will be in a de-energized state. ENERGIZED ACTIVE allows BACnet writes and energizes the output relay when the Present_Value is ACTIVE. ENERGIZED INACTIVE allows BACnet writes and energize the output relay when the Present_Value is INACTIVE. 	<p>D: DISABLED</p> <p>R: DISABLED ENERGIZED ACTIVE ENERGIZED INACTIVE</p>
<p>DISCONNECT WIFI – Disconnects the thermostat from the Wi-Fi network.</p> <p> CAUTION Disconnecting the Wi-Fi requires setting up the Connect Thermostat using the Connect mobile application in order to re-establish Wi-Fi connectivity.</p>	
<p>INSTALLATION TEST – See Installation Test (page 35) for detailed instructions.</p>	

Parameter Name/Description	Default and Range
RESTORE DEFAULTS – Press and hold the 5 button for 5 seconds to initiate and restore all system setting defaults. Press the CANCEL button to go back to SYSTEM SETTINGS screen.	

Operating your system using the Carrier® Connect™ Wi-Fi Thermostat

The thermostat supports the following types of constant volume units:

- Standard heat/cool unit types with up to 3 stages of mechanical cooling, up to 2 stages of gas or electric heating, and up to 4 stages for non-Carrier heat pumps
- Heat pump units utilizing a reversing valve output for heating and cooling control
- Carrier heat pump unit with an OEM defrost control board

NOTES

- Humidification or dehumidification control strategies are available for appropriately equipped units.
- The following configurations have interdependencies that may preclude the use of others:
 - Reversing valve
 - Third-stage cooling
 - Humidification
 - Dehumidification
 - Occupancy Output
 - The flex outputs, Y3, O, and W2, may be available for optional functions.

EXAMPLE In a single stage heating system, the W2 output could be used as the Occupancy output to enable the ECON during occupied periods.

Occupancy

Configure the thermostat to operate in a programmable or non-programmable mode. Non-programmable operates continuously in occupied mode. Programmable operates as a 7-day programmable thermostat for either 2 or 4 periods per day. You can set each period as occupied or unoccupied.

If you configure **Smart Recovery** for 30 to 90 minutes, the occupied start time increases up to the maximum time, in order to bring the space to the occupied setpoints at actual occupied time.

Supply fan

Configure the supply fan for **ON** or **AUTO**, in either occupied or unoccupied mode.

- **ON** – Fan runs continuously regardless of demand
- **AUTO** – Fan cycles heat or cool demand if there is a demand for humidity or dehumidification

Cooling

The thermostat's application and configuration determine the specific cooling sequence. It can control up to 2 stages of cooling, with an additional output for a reversing valve, for non-Carrier heat pump applications, or up to 3 stages of cooling for non-heat pump applications.

NOTE The cooling stages are controlled based on a drift algorithm and the configurable **DIFFERENTIAL** value (.5° F default).

The following conditions must be true for the cooling to operate:

- The OAT must be above the **COOL LOCKOUT** (55° F default), if enabled
- The cooling stage 5-minute minimum off-timer has expired
- The space temperature has exceeded the cooling setpoint by the **DIFFERENTIAL** value (.5° F default)

Additional stages are added and dropped, based on demand using the **DIFFERENTIAL** value, **STAGE DELAY** timer, and **FORCED STAGE UP** timer configuration values. If the **LOW COOL LOCKOUT** is configured for **ON**, or between 80 and 110° F, and the OAT is equal to or greater than that value, cool stages 1 and 2 are energized on a demand for cooling and remain on until the cooling demand is satisfied.

NOTE Once a cooling stage is energized, it remains on for a minimum of 5 minutes, regardless of demand.

Econ enable

The thermostat's application and configuration determine the specific economizer enable sequence. You can enable an output relay in OCCUPANCY OUTPUT. The output is ON whenever the thermostat is Occupied and OFF when Unoccupied.

NOTE The relay options may be limited by other programming options such as Humidity control, Heat Pump, etc..

The status of the economizer may be monitored using a dry contact (N.O.) on the **Remote Sensor Input**.

Heating

The thermostat's application and configuration determine the specific heating sequence. It can control up to 4 stages of heating when configured for non-Carrier heat pump applications, or up to 2 stages of heating for non-heat pump applications. When applied to a Carrier commercial heat pump, **HEAT TYPE** must be set to **GAS**. **HEAT TYPE** set to **ELECTRIC** supports the Carrier 3-stage heat operation using 2 outputs. See *Outputs based on demand and configuration* (page 36).

NOTE The heating stages are controlled, based on a drift algorithm and the configurable **DIFFERENTIAL** value (.5° F default).

The following conditions must true for heating to operate:

- The OAT must be below the **HEAT LOCKOUT** (55 °F default), if enabled
- The heating stage 5-minute minimum off-timer has expired
- The space temperature has exceeded the heating setpoint by the **DIFFERENTIAL** value (.5 °F default)

Additional stages are added and dropped, based on demand, using the **DIFFERENTIAL** value, **STAGE DELAY** timer, and **FORCED STAGE UP** timer configuration values. If the **LOW HEAT LOCKOUT** is configured for **ON**, or between 20 and 5 °F, and the OAT is equal to or less than that value, heat stages 1 and 2 are energized on a demand for heating and remain on until the heating demand is satisfied.

NOTE Once a heating stage is energized, it will remain on for a minimum of 5 minutes, regardless of demand.

Dehumidification

There is occupied and unoccupied dehumidification on units that are equipped with the Carrier Humidi-MiZer™ from the factory, or by energizing the first stage of cooling and over-cooling by 2 °F.

The following conditions must be true for dehumidification to operate:

- For the Humidi-MiZer™ option, **DEHUMIDIFY** must be set to **HUMIDIMIZER**
- For over-cooling, **DEHUMIDIFY** must be set to **OVRCL 2 °F**
- For non-Humidi-MiZer™ units, **DEHUMIDIFY** must be set to **YES** and must not have an active call for heating or cooling
- Setpoint range is 35 to 65%
- Humidity must be 2% greater than the dehumidify setpoint

Dehumidification ends when **DEHUMIDIFY** is set to:

- **HUMIDIMIZER** and humidity drops 3% below the dehumidify setpoint
- **OVRCL2 °** and space temperature drops below the cooling setpoint by more than 2 °F
- **YES** and space temperature drops below the calculated setpoint or there is a demand for heat or cool.

NOTE For details about this calculation, see *HUMIDITY* (page 28).

Humidification

There is occupied and unoccupied humidification on units that are equipped with humidifiers.

The following conditions must be true for humidification to operate:

- **HUMIDIFIER** must be set to **YES**
- Must be in heating mode
- Setpoint range is 15 to 50%
- Humidity must be 3% less than the humidify setpoint

Humidification ends when the humidity rises 3% above the humidify setpoint or the heating demand is satisfied.

Filter status

FILTER STATUS is based on a supply fan runtime, which you can configure from 500 to 3000 hours. A filter status alert  displays when the filter timer exceeds the configured number of hours. Press to see message.

Holidays

There is a maximum of 24 holiday periods. You can program each holiday period based on a start and stop month date, or day of the month and week, with duration up to 365 days. The holiday schedule uses the first unoccupied period setpoints for temperature control.

BACnet integration

There are two points that act as gateways, allowing or prohibiting BACnet writes to configuration items (**BACNET CONFIG WRITE**) and occupancy control (**BACNET BMS OCC**). These variables are only accessible via the local screen.

See *To configure advanced SYSTEM SETTINGS* (page 14) for BACnet set-up and control.

A write to the Active Heat or Cool Setpoint (AV:409 or AV:410) places the thermostat into temporary override. This override will remain in effect until the MAX Temperature Hold Time (AV:502) expires. Default is 2 hours.

Long-term setpoint adjustment is accomplished by writing to the baseline setpoints (AV:400- AV:403).

Using the Carrier® Connect™ Wi-Fi Thermostat's screens



HOME

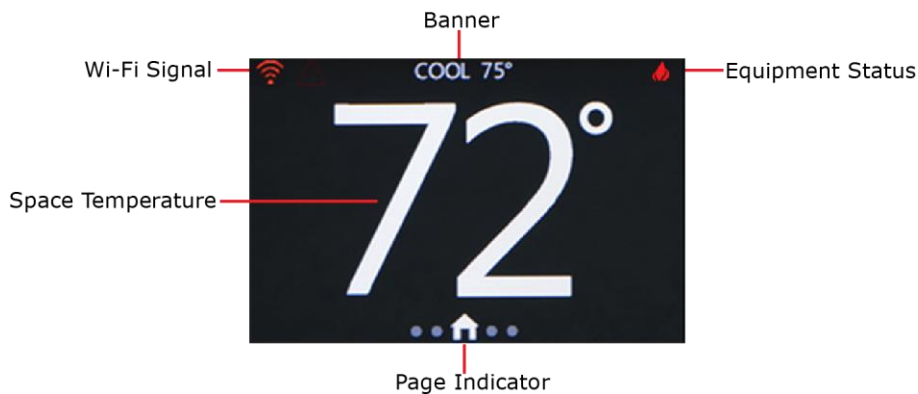

The **HOME** screen is typically what the end user sees.



Screen functions

- **Banner**
 - Press the center of the scrolling Banner to switch to the screen indicated by the displayed text. You can swipe the banner to change options, or, every 3 seconds, a different screen name scrolls across the top that you can navigate to.

NOTE On the thermostat itself, you can select those screens on the **SYSTEM SETTINGS > BANNER** screen.
- **Page Indicator** — You can tap the **HOME**  icon at any time to go to the **HOME** screen. You can either swipe or tap the dots to the left or right to navigate. The dot turns from gray to white to indicate the page you are on.
- **Wi-Fi Signal**
 -  The more green bars, the stronger the signal
 -  Red indicates it is not currently connected to a router
 - Pressing the **Wi-Fi Signal** displays a screen with connectivity details
- **Space Temperature** — The center portion of the screen displays the sensed space temperature, in whole numbers only. Fahrenheit is the default scale but you can change to Celsius in **SYSTEM SETTINGS**. See *To configure advanced System Settings* (page 14).

- **Equipment Status** — This button is static except when equipment is being activated and then it pulses on and off.
 - If you tap the **Fan mode/operation**  icons, the screen switches to the **FAN** screen.
 - If you tap the **Heat**  or **Cool**  icons, the screen switches to the **MODE** screen.

SETPOINT

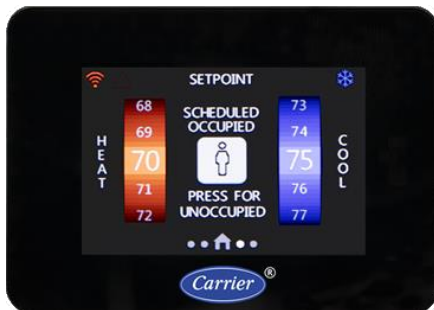

Use this screen to view, adjust, or hold heat and cool setpoints. Use the wheels to adjust setpoints. Drag a wheel up or down or tap the top or bottom of the wheel to increase or decrease by 1 increment.

There are 2 different buttons that can appear in the center of this screen. Press to switch buttons and functions.

- **OCCUPIED/UNOCCUPIED** button
- **PLAY** button allows you to either play (use as is) or alter the program schedule
- Text on top of the button is the current state
- Text beneath the button is what will happen when you press the button

If the schedule is running, the Occupancy button and the text display whether the schedule is currently running **OCCUPIED** or **UNOCCUPIED** setpoints. Press the button to switch heat and/or cool setpoints between Occupied and Unoccupied settings and then the Occupancy button changes to the **PLAY** button.

When the schedule is not running, the text above the Play button says **OCCUPIED** if the heat and cool setpoints are the same as the **OCCUPIED** setpoints or **UNOCCUPIED** if the heat and cool setpoints match the Unoccupied setpoints. If neither is true, **HOLD** displays. When the schedule is paused, the remaining hold time shows in the lower right corner.

MODE

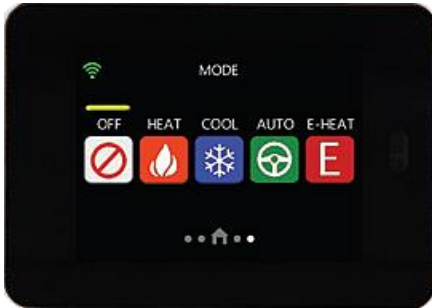

Use this screen to view and change the current **MODE**, including:

- **OFF**
- **HEAT**
- **COOL**
- **AUTO**
- **E- HEAT**

NOTE The horizontal yellow bar always appears above the current mode.

The thermostat does not change until the newly selected **MODE** has been on for at least 10 seconds.

EXAMPLE

When changing the **MODE** from **HEAT** to **COOL**, the thermostat must first satisfy any **Minimum ON Timer** requirements and then restart the **Minimum OFF Timer** that must expire before the equipment IS turned on in the new **MODE**. Going from any **HEAT** or **COOL** to **OFF**, immediately shuts off any active equipment after the 10 second delay.

SETTINGS

Use this screen to change or view the options in the thermostat. The advanced **SYSTEM SETTINGS** screens are only available from the thermostat. See *To configure advanced SYSTEM SETTINGS* (page 14).

Press a button or scroll the vertical yellow Row Indicator to see more buttons. When you press a button, the corresponding screen appears so you can view status and make adjustments.

HUMIDITY

To adjust the thermostat's humidify and dehumidify setpoints:

- Drag the wheel up or down
- Tap the top of the wheel to decrease the setpoint by 1%
- Tap the bottom to increase the setpoint by 1%.

If cooling equipment is not available, **COOL TO DEHUMIDIFY** is not adjustable on the thermostat and the blue Dehum Setpoint wheel is not adjustable.

HUMIDIFY – not adjustable on the thermostat (the orange Hum Setpoint wheel is not adjustable) unless configured to use one of the following outputs:

- O/B
- Y3
- W2

DEHUMIDIFY = YES – When humidity is above the dehumidify target, the cooling setpoint is adjusted downward, increasing cooling demand, according to the equations in the following table, when you select **YES** for **DEHUMIDIFY** (not true for **OVERCOOL (2)** or **HUMIDIMIZER** selections).

Cooling Setpoint	Algorithm
< = 70°F	Use the cooling setpoint only
70.1° - 74.9°F	Cooling setpoint = Cooling Setpoint - (Cooling Setpoint - 70°F) x (Dehumidify Error / 10) with maximum dehumidify Error of 6% (i.e. use 6% if >6%)
> = 75°	Cooling setpoint = Cooling Setpoint - (Dehumidify Error / 2) with maximum dehumidify Error of 6%

When cooling to dehumidify, the minimum ON timer increases to 5 minutes and the second stage (or greater) is not started unless there is also a cooling demand.

OVERCOOL 2° commands the system to operate the compressor, within limits, when there is a dehumidification demand, even if there is no cooling demand. The system may overcool up to 2°F and no more, when satisfying a dehumidification demand.

Humidi-MiZer™

When configured as a **HUMIDIMIZER** output, and the humidity level is above the dehumidify target, 24V is output at the selected terminal. When the humidity level is below the dehumidify target, 0 Vac is output on the selected terminal. There is a +1/-4% hysteresis around the dehumidify target to prevent rapid on/off cycling of the selected output.

This output may be connected to compressor outputs on commercial equipment. If the selected output is energized without any compressors being energized, the 5-minute time guard must be enforced.

Use the following table to determine values for the terminal outputs to the equipment, when specific demands are present.

NOTES

- The value of X denotes that the setting may be **Off** or **On**, depending on the state of the **FAN ON WITH W** set on advanced **SYSTEM SETTINGS** screen.
- * represents Y3, W2, or O/B, based on the item available and selected in **HUM/DEHUM OUTPUT** configuration. See *To configure advanced System Settings* (page 14).

	Y1	Y2	W1	W2	G	*
Fan	Off	Off	Off	Off	On	Off
Cool (1)	On	Off	Off	Off	On	Off
Cool (2)	On	On	Off	Off	On	Off
Dehumidify (HUMIDIMIZER)	Off	Off	Off	Off	On	On
Cool (1) and Dehumidify	On	Off	Off	Off	On	On
Cool (2) and Dehumidify	On	On	Off	Off	On	On
Heat (1)	Off	Off	On	Off	X	Off
Heat (2)	Off	Off	On	On	X	Off
Heat (1) and Humidify	Off	Off	On	Off	X	On
Heat (2) and Humidify	Off	Off	On	On	X	On

FAN

Use this screen to adjust fan operation. The default setting for fan operation is **AUTO** for both **OCCUPIED** and **UNOCCUPIED** periods. When operating in **AUTO MODE**, the fan only runs when there is an active heating or cooling demand. When you select **ON**, the fan runs continuously, except during the **BLOWER ON DELAY** when a heat cycle is starting. There will be a 30-second minimum on/off timer when changing the **FAN MODE**.

These selections are not available if the thermostat has been configured for non-programmable operation.



CAUTION The **AUTO** selection is a violation of the ASHRAE 90.1 and California Title 24, but is a feature of the thermostat for building owners that mandate auto fan operation during occupied periods for energy conservation purposes.

PROGRAM

The top center of the screen displays the program schedule day of the week. Swipe up or down to move from one day to the next on the program schedule. The vertical yellow Row Indicator moves up and down at the same time.

- The horizontal blue lines show the cool setpoints above, for each of the 4 programmable periods of the day (up to 3 occupied periods and 1 unoccupied period, if configured).
- The horizontal red lines show the heat setpoints below, for each of the 4 programmable periods of the day.
- Occupied and Unoccupied appear at the top of each period.

- The vertical dashed lines separate the program time changes throughout the day.
- The times at the bottom of the dashed lines show the schedule. Click on time to edit transition time.
- The vertical yellow dashed line displays the current time of day.
- The yellow lines show up only when viewing the current day of the week.

HOLIDAY

This screen displays the current year's holiday schedule. On a holiday, the setpoints for the first **UNOCCUPIED** time range are used for the entire day. Scroll the vertical yellow Row Indicator to see more holidays. Click on the holiday to make edits.

BANNER

Press the center of the scrolling Banner to switch to the screen indicated by the text. You can swipe the banner to change options, or, every 3 seconds a different screen name scrolls across the top that you can navigate to.

On the thermostat itself, you can select which screens you want on the Banner by pressing the buttons to check the ones you want and then uncheck the ones you do not want.

The default screens are:

- **DATE & TIME**
- **FAN STATUS**
- **OUTDOOR TEMP**
- **COOL SETPOINT**
- **HUMIDITY**
- **HEAT SETPOINT**

DATE and TIME

On this screen, scroll or tap the Orange Hour wheel or Blue Minute wheel to adjust the date and time on the thermostat.

Switch to the **Date Adjust** screen and the **Time Adjust** screen using the green icon button at the right side of the screen. Scroll or tap the Orange Month wheel or Blue Day wheel.

Drag a wheel up or down or tap the top or bottom of the wheel to increase or decrease by 1 increment.

When the thermostat is first registered and connected to a Wi-Fi router, both the date and time are synced with the server (based on the location of the phone/tablet used to connect the thermostat to a router or based on the ISP location if a computer is used to connect the thermostat to a router). The time and date are synced at the top of each hour automatically, unless the **Sync Time To Server** option in the **SETTINGS > ADVANCED** screen is set to **NO**.

SOFTWARE screen and BACKLIGHT screen

SOFTWARE – Displays the current software's status.

BACKLIGHT – Use to change the backlight intensity in Active and Dormant modes.

- The blue Active Backlight wheel adjusts the backlight intensity from 10 to 100%, (75% is the default and recommended) when the thermostat is in an active state (being accessed or viewed by the end user).
- The purple Dormant Backlight wheel adjusts backlight intensity from 0 to 25%, (25% is the default and recommended) when the thermostat is in a dormant state (not being viewed or adjusted by the end user).

Drag a wheel up or down or tap the top or bottom of the wheel to increase or decrease by 1 increment.

ADVANCED

Use this screen to access and change more advanced settings.

Screen Name/Description	Default and Range
SYNC TIME TO SERVER – Sync time and date with cloud server based on thermostat location, which is determined by your mobile app or ISP during setup	D: YES R: NO/YES
SCREEN TIMEOUT – The maximum amount of time the BACKLIGHT stays active when no activity is sensed at the thermostat	D: 15 SEC R: 5 to 30 SEC (5 second intervals)
PROXIMITY – Enable or disable proximity sensing that changes the screen backlighting from Dormant to Active when a person is sensed in front of the thermostat	D: YES R: NO/YES
PROX SENSITIVITY – Change the proximity sensing feature from HIGH to MEDIUM to LOW. Increasing the sensitivity increases the range the sensor can detect presence, but also increases the possibility of a false presence.	D: MEDIUM R: HIGH/MEDIUM/LOW
# PROGRAM DAY PARTS – Number of periods per day for programming occupancy	D: 2 R: 2 or 4
DST – Enable or disable automatic Daylight Saving Time change in the thermostat	D: ENABLED R: DISABLED/ENABLED

Screen Name/Description	Default and Range
<p>WIRELESS — Enable or disable Wi-Fi for the thermostat. If disabled, then the Wi-Fi radio in this product is turned off and functions, such as the following, are not available:</p> <ul style="list-style-type: none"> • Sync Time To Server • Outdoor Temperature via Wi-Fi Geo location • Server & Wi-Fi Errors • Remote Access Services via app or Web <p> CAUTION If you disable this function after the thermostat has been set up and connected to the local Wi-Fi network, you must set it up again using the mobile App.</p>	<p>D: ENABLED</p> <p>R: ENABLED/DISABLED</p>
<p>SOUND — Adjust the sound made when touching the thermostat</p>	<p>D: CLICK</p> <p>R: OFF, CLICK, or BEEP</p>

FILTER

Available on the thermostat only.

Use to reset the **FILTER ALERT** and see the **FILTER RESET REMINDER** timer information. Press the **RESET** button to reset the timer to its configured value in the advanced **SYSTEM SETTINGS**. See *To configure advanced SYSTEM SETTINGS* (page 14).

LOCKOUT

Locks out unauthorized changes made on the touchscreen. All touch interaction is locked out without the unlock code. After 5 failed attempts, a notification (fault) is sent to the registered owner of the thermostat through Wi-Fi. More unlock attempts are blocked for 15 minutes.

To set up a new PIN or change the current PIN, select the **ENABLE** button or the **CHANGE PIN** button, which displays on the **SET PIN** screen. If the thermostat does not already have a PIN, the **CHANGE PIN** button cannot be used.

On the **SET PIN** screen, use the 3 blue-digit **PIN** wheels to set the **PIN**. Set the 3-digit PIN and press the orange Save button to save the PIN and return to the **LOCKOUT** screen. Press the **DISABLE** button to cancel the **LOCKOUT** function and reset the **PIN** to **000**. The default is **000** and the range is **1** to **999**.

CLEAN

Stops touchscreen interaction for 10 seconds to allow cleaning the screen with a dry nonabrasive cloth. A 10-second countdown shows on the **CLEAN** screen and then resumes normal operation.

LOG

You can use this screen to view software update history, fault history, and system events. Swipe up or down on the vertical yellow Row Indicator to scroll through logged events.

The log includes:

- **STARTUP**
- **SOFTWARE UPDATE EVENTS**
- **POWER CYCLE EVENTS**
- **PARAMETER OUT-OF-RANGE EVENTS**
- **SERVER CONNECTIVITY EVENTS**
- **NON-VOLATILE MEMORY FAULTS**
- **TEMPERATURE FAULTS**

The list displays the 5 most recent logged events, with the most recent at the top. The last line in the list includes the **RESET LOG** command to clear the list. Pressing an event item displays a screen with more information. Press the **BACK** button to return to the **LOG** screen.

STATUS

Displays the current status of

- thermostat outputs
- timers
- stages
- lockouts

Current timer status is displayed and can be cleared for testing and troubleshooting by pressing and holding the **TIMERS** text for 5 seconds. Press and hold **LOCKOUT TIMERS** for 5 seconds to clear timer values for **COOL, E-HEAT, and HP HEAT**.

Scroll the vertical yellow Row Indicator to see more options.

SERVICE

Displays the dealer/installer service contact information. This information is editable using the mobile app, LAN mode transfer, and Wi-Fi transfer.

Installation test

Complete the following to field test the Carrier® Connect™ Wi-Fi Thermostat's outputs.

- 1 Press the **CHANGE** button to cycle the **MODE** screen through the following settings:
 - **HEATING** (default) — not available in a cooling-only configuration
 - **EM HEAT** — not available unless a heat pump is configured
 - **COOLING** — not available in a heating-only configuration
 - **FAN**

- 2 Press the **START** button.
 - a) The first stage of **HEATING, EM HEAT, COOLING, or FAN** starts running and the text reads **1ST STAGE: 180** or **FAN ON** and 180 seconds starts counting down.
 - b) The **START** button is replaced with a **STOP** button and the **CHANGE** button disappears.
 - c) Once the countdown reaches 0, if another stage exists, it starts and the text changes to **2ND STAGE: 180**.
 - d) If no other stage exists, the cycle ends, the text disappears, and the **START** button reappears.
 - e) If a third stage exists, it starts running after the second stage countdown reaches 0.
 - f) While the **HEATING** and **EM HEAT MODES** are running, if a humidifier has been configured, a **HUM** button appears below the **STOP** button. If you press the **HUM** button, the text **HUMIDIFYING** appears and turns on the humidifier.
 - g) While the **COOLING MODE** is running, if a dehumidifier has been configured, a **DEHUM** button appears below the **STOP** button and, if pressed, the text **DEHUMIDIFYING** appears and the dehumidifier turns on.
 - h) Pressing the **STOP** button turns off running equipment, the **STOP** button is replaced with the **START** button, the **CHANGE** button reappears, and the second (stage running and countdown time) and third lines (humidifying or dehumidifying), are erased.
 - i) When you press the **CANCEL** button, any equipment that is running is turned off and the **SYSTEM SETTINGS** screen displays.
 - j) When you press the **HOME** icon, any equipment that is running is turned off and the **HOME** screen displays.

After 15 minutes of inactivity (no button presses), the installer test stops and the **HOME** screen displays.

Troubleshooting

If the display does not turn on:

- 1 Check terminals R and C on the thermostat base.
- 2 Verify power is 24 Vac +/-10%.
- 3 Verify that the green LED on the base is flashing at 1 Hz.

NOTE If the green LED is not flashing and you do have 24 Vac on terminals R and C, you need to replace the thermostat.

Outputs based on demand and configuration

Demands Stages	Y1	Y2	W1	W2	G	Y3	*Rev Val=0	*Rev Val=B
Fan Only	Off	Off	Off	Off	On	Off	X	X
Cool 1 (A/C)	On	Off	Off	Off	On	Off	X	X
Cool 2 (A/C)	On	On	Off	Off	On	Off	X	X
Cool 3 (A/C)	On	On	Off	Off	On	On	X	X
Cool 1 (Heat Pump)	On	Off	Off	Off	On	X	On	Off
Cool 2 (Heat Pump)	On	On	Off	Off	On	X	On	Off
Dehumidify	Off	Off	Off	Off	On	X	X	X
Cool 1 and Dehumidify	On	Off	Off	Off	On	X	X	X
Cool 2 and Dehumidify	On	On	Off	Off	On	X	X	X
Heat 1 (A/C)	Off	Off	On	Off	On	X	X	X
Heat 2 (A/C)	Off	Off	On	On	On	X	X	X
Heat 1 (Heat Pump)	On	Off	Off	Off	On	X	Off	On
Heat 2 (Heat Pump)	On	On	Off	Off	On	X	Off	On
Heat 3 (HP w/Emerg Ht)	On	On	On	On	On	X	Off	On
Heat 4 (HP w/Emerg Ht)	On	On	On	On	On	X	Off	On
Heat 1 and	Off	Off	On	Off	On	X	X	X

Demands Stages	Y1	Y2	W1	W2	G	Y3	*Rev Val=0	*Rev Val=B
Dehumidify								
Heat 2 and Dehumidify	Off	Off	On	On	On	X	X	X
Heat Low (Electric)	Off	Off	On	Off	On	X	X	X
Heat Med (Electric)	Off	Off	Off	On	On	X	X	X
Heat High (Electric)	Off	Off	On	On	On	X	X	X

NOTE Use this table along with the **HUM/DEHUM** table, if either of those functions are enabled. See *HUMIDITY* (page 28).

Fault definitions

The following Fault messages are displayed and logged in the banner during the fault condition and then sent to the Cloud server.

Faults	Condition
ID TEMP SENSOR HIGH	Temperature reading > 122° F
ID TEMP SENSOR LOW	<ul style="list-style-type: none"> • Temperature reading = 0 • Reading not available
REMOTE SENSOR HIGH	Remote temperature > 122° F NOTE Displayed only if REMOTE SENSOR is set to INDOOR or AVERAGE .
REMOTE SENSOR LOW	Remote temperature = 0 NOTE Displayed only if REMOTE SENSOR is set to INDOOR or AVERAGE .
HUM TEMP SENSOR HIGH	Humidity sensor temperature > 122° F NOTE Displayed only if using humidity temperature as a backup source during a fault condition with the primary temperature sensor.
HUM TEMP SENSOR LOW	Humidity sensor temperature = 0 NOTE Displayed only if using humidity temperature as a backup source during a fault condition with the primary temperature sensor.
ID TEMP RANGE HIGH	Indoor Temp above cooling setpoint plus MAX SETPOINT ERROR
ID TEMP RANGE LOW	Indoor Temp below heat setpoint minus MAX SETPOINT ERROR
HUM SENSOR FAILURE	Any of the following: <ul style="list-style-type: none"> • Humidity sensor timed out • Humidity reading is > 99% • Humidity reading is 0

Faults	Condition
HUMIDITY RANGE HIGH	Humidity reading is > 90%
HUMIDITY RANGE LOW	Humidity reading is < 10%
OUTDOOR SENSOR FAILURE	OD temp > 127 or < -60
NOT CONNECTED TO SERVER	Not connected to Ayla server
NOT CONNECTED TO ROUTER	Router signal strength is 0 = no bars = not connected
WI-FI HARDWARE FAULT	Communications error occurred with Wi-Fi module (resets after valid message received)
ECONOMIZER FAULT	Contact closure on remote sensor input, as determined by Economizer
LOCKOUT	User has entered incorrect pin 5 consecutive times

Recovering from a power outage

The Carrier® Connect™ Wi-Fi Thermostat stores the following critical information in a non-volatile flash memory:

- Installer settings
- Owner settings
- Program schedule
- Software information
- Dealer information
- Fault and system event information
- Date and time

The Carrier® Connect™ Wi-Fi Thermostat uses a capacitor to maintain date and time for approximately 2 hours, in order to maintain data during short power interruptions. If the power outage is longer than 2 hours, the date and time will automatically be updated once network connection is re-established.

Resetting wi-fi access

To assign a new Wi-Fi access point or transfer the Carrier® Connect™ Wi-Fi Thermostat to a new account, follow these steps.

- 1 On the thermostat, not a mobile device, swipe the **HOME** screen twice to the left to navigate to the **MODE** screen and ensure the **MODE** is **OFF**.

NOTE The yellow line above a button indicates the current **MODE**.

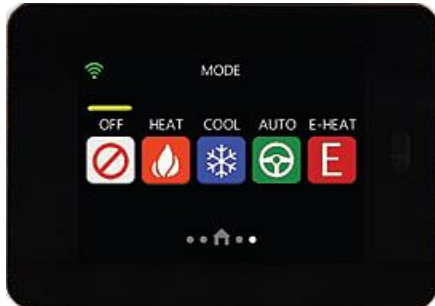

- 2 Swipe to go to the **FAN** screen and then press and hold the **Fan Button**  for 5 seconds to get to the **SYSTEM SETTINGS** screen.

NOTE You can **ONLY** access the **SYSTEM SETTINGS** screens from the thermostat itself, not the app or web.

- 3 Enter the 3-digit security PIN code, if applicable, to open the **SYSTEM SETTINGS** screen.



- 4 Scroll down to **DISCONNECT WIFI**.



CAUTION Disconnecting the Wi-Fi requires setting up the Connect Thermostat using the Connect mobile application.

- 5 Select **YES**.
- 6 Use the mobile app on your phone or tablet to connect the thermostat to the desired Wi-Fi Access point. See the section of this guide titled “*Registering and setting up a mobile device for enhanced access (page 9)*”. Follow the instructions within the app.

Compliance

FCC Compliance

This device complies with Part 15 of the FCC Rules. Operation is subject to the following two conditions:

- 1 This device may not cause harmful interference.
- 2 This device must accept any interference received, including interference that may cause undesired operation.



IMPORTANT Any changes or modifications not expressly approved by manufacturer could void the user's authority to operate the equipment.

NOTE This equipment has been tested and found to comply with the limits for a Class B digital device, pursuant to Part 15 of the FCC Rules. These limits are designed to provide reasonable protection against harmful interference when the equipment is operated in a residential installation. This equipment generates, uses, and can radiate radio frequency energy, and if it is not installed and used in accordance with this document, it may cause harmful interference to radio communications. However, there is no guarantee that interference will not occur in a particular installation. If this equipment does cause harmful interference to radio or television reception, which can be determined by turning the equipment off and on, the user is encouraged to try to correct the interference by one or more of the following measures:

- Reorient or relocate the receiving antenna.
- Increase the separation between the equipment and receiver.
- Connect the equipment into an outlet on a circuit different from that to which the receiver is connected.
- Consult the dealer or an experienced radio/TV technician for help.

BACnet Compliance

Compliance of listed products to requirements of ASHRAE Standard 135 is the responsibility of BACnet International. BTL[®] is a registered trademark of BACnet International.

Appendix: BACnet Points List

Point Name	Point Access	Units	BACnet Point Name	BACnet Object ID
Indoor Space Temperature	WRITE_WHEN_OOS	DEGREES_FAHRENHEIT	ID_SPACE_TEMP	AI:100
Indoor Space Humidity	WRITE_WHEN_OOS	PERCENT_RELATIVE_HUMIDITY	ID_SPACE_HUM	AI:101
Remote Space Temperature	READ_ONLY	DEGREES_FAHRENHEIT	REM_SPACE_TEMP	AV:100
Outdoor Temperature	READ_ONLY	DEGREES_FAHRENHEIT	OD_TEMP	AV:101
Supply Air Temperature	READ_ONLY	DEGREES_FAHRENHEIT	SAT	AV:102
Network Space Temperature	READ_WRITE	DEGREES_FAHRENHEIT	NET_SP_TEMP	AV:103
Space Temperature for Control	READ_ONLY	DEGREES_FAHRENHEIT	SP_TEMP_CTRL	AV:104
Network Space Humidity	READ_WRITE	PERCENT_RELATIVE_HUMIDITY	NET_SP_HUM	AV:105
Space Humidity for Control	READ_ONLY	PERCENT_RELATIVE_HUMIDITY	SP_HUM_CTRL	AV:106
Air Filter Hours Left	READ_ONLY	HOURS	AIR_FLTR_HRS_LFT	AV:300
Override Time Remaining	READ_ONLY	SECONDS	OVRD_TIME	AV:301
Occupied Heat Setpoint	READ_WRITE	DEGREES_FAHRENHEIT	OCC_HT_SP	AV:400
Occupied Cool Setpoint	READ_WRITE	DEGREES_FAHRENHEIT	OCC_CL_SP	AV:401
Unoccupied Heat Setpoint	READ_WRITE	DEGREES_FAHRENHEIT	UNOCC_HT_SP	AV:402
Unoccupied Cool Setpoint	READ_WRITE	DEGREES_FAHRENHEIT	UNOCC_CL_SP	AV:403
Dehumidification Setpoint	READ_WRITE	PERCENT_RELATIVE_HUMIDITY	DEHUM_SP	AV:406
Humidification Setpoint	READ_WRITE	PERCENT_RELATIVE_HUMIDITY	HUM_SP	AV:407
Screen Timeout	READ_WRITE	MINUTES	SCRN_TMT	AV:408
Heat Setpoint	READ_WRITE	DEGREES_FAHRENHEIT	HEAT_SP	AV:409
Cool Setpoint	READ_WRITE	DEGREES_FAHRENHEIT	COOL_SP	AV:410
Active Backlight	READ_WRITE	PERCENT	ACTV_BCKLT	AV:411
Dormant Backlight	READ_WRITE	PERCENT	DRMNT_BCKLT	AV:412
Indoor Equip Stages	GATED_WRITE	PERCENT_RELATIVE_HUMIDITY	ID_STAGES	AV:500
Outdoor Equip Stages	GATED_WRITE	DEGREES_FAHRENHEIT	OD_STAGES	AV:501
Max Temperature Hold Time	GATED_WRITE	HOURS	MAX_HOLD_TIME	AV:502
Auto Changeover Delay	GATED_WRITE	MINUTES	AUTO_XOVR	AV:503
Cool Lockout Temperature	GATED_WRITE	DEGREES_FAHRENHEIT	COOL_LOCKOUT	AV:504
High Cool Lockout (HP only)	GATED_WRITE	DEGREES_FAHRENHEIT	HI_CL_LCKOUT	AV:505
High Heat Lockout (HP only)	GATED_WRITE	DEGREES_FAHRENHEIT	HI_HT_LCKOUT	AV:506
Delay Between Fuel (HP only)	GATED_WRITE	MINUTES	DLY_BW_FUEL	AV:507
Cycles Per Hour	GATED_WRITE	CYCLES_PER_HOUR	CYCLES_HR	AV:508
Max Heat Setpoint	GATED_WRITE	DEGREES_FAHRENHEIT	MAX_HT_SP	AV:509
Min Cool Setpoint	GATED_WRITE	DEGREES_FAHRENHEIT	MIN_CL_SP	AV:510
Aux Heat Lockout (HP only)	GATED_WRITE	DEGREES_FAHRENHEIT	AUX_HT_LCKOUT	AV:511
Heat Pump Lockout	GATED_WRITE	DEGREES_FAHRENHEIT	HP_LCKOUT	AV:512
Stage Delay	GATED_WRITE	MINUTES	STG_DELAY	AV:513
Forced Stage Up Delay	GATED_WRITE	MINUTES	FRCD_STG_UP	AV:514
Stage Change Temp Differential	GATED_WRITE	DELTA_DEGREES_FAHRENHEIT	DIFFERENTIAL	AV:515
Line Frequency	GATED_WRITE	HERTZ	LINE_FREQ	AV:516
Indoor Temperature Offset	GATED_WRITE	DELTA_DEGREES_FAHRENHEIT	ID_TEMP_OFF	AV:517
Indoor Humidity Offset	GATED_WRITE	PERCENT_RELATIVE_HUMIDITY	ID_HUM_OFF	AV:518

Appendix: BACnet Points List

Point Name	Point Access	Units	BACnet Point Name	BACnet Object ID
SAT Temp Offset	GATED_WRITE	DELTA_DEGREES_FAHRENHEIT	SAT_OFFSET	AV:519
Air Filter Hours	READ_ONLY	HOURS	AIR_FLT_HRS	AV:520
Max Setpoint Error	GATED_WRITE	DELTA_DEGREES_FAHRENHEIT	MAX_SP_ERR	AV:521
Indoor Temp Fault Inhibit	GATED_WRITE	MINUTES	ID_TMP_FLT_INHBT	AV:522
1st Stage Cooling Out Status	READ_ONLY	0=OFF 1=ON	Y1_OUT	BV:200
2nd Stage Cooling Out Status	READ_ONLY	0=OFF 1=ON	Y2_OUT	BV:201
3rd Stage Cooling Out Status	READ_ONLY	0=OFF 1=ON	Y3_OUT	BV:202
1st Stage Heating Out Status	READ_ONLY	0=OFF 1=ON	W1_OUT	BV:203
2nd Stage Heating Out Status	READ_ONLY	0=OFF 1=ON	W2_OUT	BV:204
Fan Out Status	READ_ONLY	0=OFF 1=ON	G_OUT	BV:205
Reversing Valve Out Status	READ_ONLY	0=OFF 1=ON	OB_OUT	BV:206
Occupancy Out Status	READ_ONLY	0=OFF 1=ON	OCC_OUT	BV:208
Humidifier Out Status	READ_ONLY	0=OFF 1=ON	HUM_OUT	BV:209
Dehumidifier Out Status	READ_ONLY	0=OFF 1=ON	DEHUM_OUT	BV:210
Network General Purpose Out Y3	READ_WRITE	0=OFF 1=ON	NET_GP_Y3_OUT	BV:211
Network General Purpose Out W2	READ_WRITE	0=OFF 1=ON	NET_GP_W2_OUT	BV:212
Network General Purpose Out OB	READ_WRITE	0=OFF 1=ON	NET_GP_OB_OUT	BV:213
Wi-Fi Time Synchronization	READ_WRITE	0=DISABLED 1=ENABLED	WIFI_TIME_SYNC	BV:400
Proximity Sensor Enable	READ_WRITE	0=DISABLED 1=ENABLED	PROXIMITY_EN	BV:401
Auto DST Time Shift	READ_WRITE	0=DISABLED 1=ENABLED	AUTO_DST	BV:402
Wi-Fi Enable	READ_WRITE	0=DISABLED 1=ENABLED	WIFI_ENABLE	BV:403
Setpoint Override	READ_WRITE	0=DISABLED 1=ENABLED	SETPT_OVERRIDE	BV:404
BACnet BMS Occupancy	GATED_WRITE	0=UNOCCUPIED 1=OCCUPIED	BMS_OCC	BV:405
Filter Timer Reset	READ_WRITE	0=INACTIVE 1=ACTIVE	FLTR_TMR_RST	BV:406
Occupancy Input Polarity	GATED_WRITE	0=OCCUPIED 1=UNOCCUPIED	OCC_IN_POL	BV:500
Auto Mode Allowed	GATED_WRITE	0=NO 1=YES	ALLOW_AUTO	BV:501
Prog Mode Allowed	GATED_WRITE	0=NO 1=YES	ALLOW_PROG	BV:502

Point Name	Point Access	Units	BACnet Point Name	BACnet Object ID
Celsius Display	GATED_WRITE	0=F° 1=C°	CELSIUS_DISP	BV:503
Fan On with W	GATED_WRITE	0=NO 1=YES	FAN_WITH_W	BV:504
Rvs Vlv Energized Ht	GATED_WRITE	0=ENERGIZED FOR COOL 1=ENERGIZED FOR HEAT	RVS_VLV_DIR	BV:505
Humidifier Installed	GATED_WRITE	0=NO 1=YES	HUM_INST	BV:506
BMS Occupancy Enable	GATED_WRITE	0=DISABLED 1=ENABLED	BMS_OCC_EN	BV:507
BACnet Config Write Enable	GATED_WRITE	0=DISABLED 1=ENABLED	CFG_WR_EN	BV:511
ID TEMP SENSOR HIGH	READ_ONLY	0=DISABLED 1=ENABLED	ID_TEMP_SENS_HI	BV:900
ID TEMP SENSOR LOW	READ_ONLY	0=INACTIVE 1=ACTIVE	ID_TEMP_SENS_LO	BV:901
REMOTE SENSOR HIGH	READ_ONLY	0=INACTIVE 1=ACTIVE	REM_TEMP_HI	BV:902
REMOTE SENSOR LOW	READ_ONLY	0=INACTIVE 1=ACTIVE	REM_TEMP_LO	BV:903
HUM TEMP SENSOR HIGH	READ_ONLY	0=INACTIVE 1=ACTIVE	HUM_TEMP_HI	BV:904
HUM TEMP SENSOR LOW	READ_ONLY	0=INACTIVE 1=ACTIVE	HUM_TEMP_LO	BV:905
ID TEMP RANGE HIGH	READ_ONLY	0=INACTIVE 1=ACTIVE	ID_TEMP_RNG_HI	BV:906
ID TEMP RANGE LOW	READ_ONLY	0=INACTIVE 1=ACTIVE	ID_TEMP_RNG_LO	BV:907
HUM SENSOR FAILURE	READ_ONLY	0=INACTIVE 1=ACTIVE	HUM_SENS_FAIL	BV:908
HUMIDITY RANGE HIGH	READ_ONLY	0=INACTIVE 1=ACTIVE	HUM_TOO_HI	BV:909
HUMIDITY RANGE LOW	READ_ONLY	0=INACTIVE 1=ACTIVE	HUM_TOO_LO	BV:910
OUTDOOR SENSOR FAILURE	READ_ONLY	0=INACTIVE 1=ACTIVE	OD_TEMP_FAIL	BV:911
NOT CONNECTED TO SERVER	READ_ONLY	0=INACTIVE 1=ACTIVE	SRVR_CONN_FAIL	BV:912
NOT CONNECTED TO ROUTER	READ_ONLY	0=INACTIVE 1=ACTIVE	RTR_CONN_FAIL	BV:913
WIFI HARDWARE FAULT	READ_ONLY	0=INACTIVE 1=ACTIVE	WIFI_CONF_FAIL	BV:914
ECONOMIZER FAULT	READ_ONLY	0=INACTIVE 1=ACTIVE	ECON_FAULT	BV:915
LOCKOUT-5 BAD PIN ENTRIES	READ_ONLY	0=INACTIVE 1=ACTIVE	LOCKOUT_FAIL	BV:916
Current Mode Status	READ_ONLY	1=OFF 2=HEAT 3=COOL	CURRENT_MODE	MSV:300
User Mode	READ_WRITE	1=OFF	USER_MODE	MSV:400

Appendix: BACnet Points List

Point Name	Point Access	Units	BACnet Point Name	BACnet Object ID
		2=HEAT 3=COOL 4=AUTO 5=E-HEAT		
IR Proximity Sensitivity	READ_WRITE	1=HIGH 2=MEDIUM 3=LOW	PROX_SENS	MSV:401
Sound Effect	READ_WRITE	1=OFF 2=CLICK 3=BEEP	SOUND	MSV:402
Number of Parts in Schedule Day	READ_WRITE	1=2 PARTS 2=4 PARTS	SCHED_DAY_PARTS	MSV:403
Occupied Fan Mode	READ_WRITE	1=AUTO 2=ON	OCC_FAN	MSV:404
Unoccupied Fan Mode	READ_WRITE	1=AUTO 2=ON	UNOCC_FAN	MSV:405
Current Fan Mode	READ_WRITE	1=AUTO 2=ON 3=OVERRIDE AUTO 4=OVERRIDE ON	FAN MODE	MSV:406
Indoor Equipment Type	READ_ONLY	1=NO INDOOR 2=FURNACE 3=AIR HANDLER	ID_EQUIP_TYPE	MSV:500
Outdoor Equipment Type	GATED_WRITE	1=NO OUTDOOR 2=A/C 3=HEAT PUMP	OD_EQUIP_TYPE	MSV:501
Remote Sensor Type	GATED_WRITE	1=NONE 2=OUTDOOR 3=SPACE 4=AVERAGE 5=OCCUPANCY 6=FAULT_INPUT 7=SAT	REMOTE_SENSOR	MSV:502
Dehumidification Type	GATED_WRITE	1=NO 2=YES 3=OVRCL(2F) 4=HUMIDIMIZER	DEHUM_TYPE	MSV:503
Occupancy Output Terminal	GATED_WRITE	1=OFF 2=Y3 3=O/B 4=W2	OCC_OUTPUT	MSV:504
Humidification Output Terminal	GATED_WRITE	1=OFF 2=Y3 3=O/B 4=W2	HUM_OUTPUT	MSV:505
Dehumidification Output Terminal	GATED_WRITE	1=OFF 2=Y3 3=O/B 4=W2	DEHUM_OUTPUT	MSV:506
Smart Recovery	GATED_WRITE	1=NO 2=30 MIN	SMART_RECVRY	MSV:507

Point Name	Point Access	Units	BACnet Point Name	BACnet Object ID
		3=60 MIN 4=90 MIN		
General Purpose Output Timeout	GATED_WRITE	1=2 MIN 2=20 MIN 3=1 HR 4=UNLIMITED	GP_OUT_TIMEOUT	MSV:508
Network GP Y3 Mode	GATED_WRITE	1=DISABLED 2=ENERGIZED_ACTIVE 3=ENERGIZED_INACTIVE	NET_GP_Y3_MODE	MSV:509
Network GP W2 Mode	GATED_WRITE	1=DISABLED 2=ENERGIZED_ACTIVE 3=ENERGIZED_INACTIVE	NET_GP_W2_MODE	MSV:510
Network GP OB Mode	GATED_WRITE	1=DISABLED 2=ENERGIZED_ACTIVE 3=ENERGIZED_INACTIVE	NET_GP_OB_MODE	MSV:511

Document revision history

Important changes to this document are listed below. Minor changes such as typographical or formatting errors are not listed.

Date	Topic	Change description	Code*
1/22/21	To wire for BACnet communication	Added 115.2 kbps baud rate	C-CP-E
7/17/20	BACnet Points List	Corrected BACnet BMS Occupancy to GATED_WRITE from READ_ONLY	C-CP-E
2/28/20	Entire book	Updated logos	C-D
1/6/20	Entire book	Updated throughout for BACnet capabilities	C-CP-E
9/27/19	Registering and setting up a mobile device for enhanced access	Removed reference to a 7-day limit for mobile devices	C-TS-CP-E
	BACnet Integration	New	C-TS-CP-E
	To connect a remote input ((sensor or contacts)	Added SAT to list of inputs.	C-TS-CP-E
	Appendix: BACnet Points List	New	C-ST-CP-E
	To configure advanced SYSTEM SETTINGS	Added SAT to REMOTE SENSOR Added BACnet parameters	C-ST-CP-E
8/28/19	Humidity	Removed note limiting output use	C-ST-CP-E

* For internal use only



CARRIER CORPORATION ©2021 · Catalog No. 11-808-728-01 · 1/22/2021