

Outdoor Unit Single Zone Heat Pump Ductless System

Outdoor Model: **38MBRBQ48AA3**

Submittal Data

Job Data:

Location:

Buyer:

Buyer P.O. #:

Carrier #:

Unit Number:

Model Number:

Performance Data Certified By:

Date:



STANDARD FEATURES

Features Outdoor:

- Variable Speed (Inverter) Compressor
- Basepan Heater factory installed
- Quiet operation
- Aluminum Hydrophilic pre-coated fins

- Piping length 213 ft. (65 m)

Cooling operating range -13° ~ 122° F (-25° ~ 50°C)

Heating operating range -22°~86°F (-30°~30°C)

LIMITED WARRANTY*

- 10 year limited to original purchaser on compressor and parts upon timely registration, otherwise 5 years

*For residential applications. See warranty for full details.

Specifications

System	Size	48	
	Outdoor Model	38MBRBQ48AA3	
Electrical	Voltage, Phase, Cycle	V/Ph/Hz	208/230-1-60
	MCA	A.	37
	MOCP - Fuse Rating	A.	50
Operating Range	Cooling Outdoor DB Min - Max	°F(°C)	-13~122 (-25~50)
	Heating Outdoor DB Min - Max	°F(°C)	-22~86 (-30~30)
Piping	Total Piping Length	ft (m)	213 (65)
	Piping Lift	ft (m)	98 (30)
	Pipe Connection Size - Liquid	in (mm)	3/8 (9.52)
	Pipe Connection Size - Suction	in (mm)	5/8 (16)
Refrigerant	Type	R410A	
	Charge	lbs (kg)	9.92 (4.5)
	Metering Device	EEV	
Outdoor Coil	Face Area	Sq. Ft.	14.8
	No. Rows	2	
	Fins per inch	18	
	Circuits	8	
Compressor	Type	R410A	
	Model	KTQ420D1UMU	
	Oil Type	ESTER OIL VG74	
	Oil Charge	Fl. Oz.	47.35
	Rated Current	RLA	28
Outdoor	Unit Width	in (mm)	40.5 (1,030)
	Unit Height	in (mm)	52.4 (1,333)
	Unit Depth	in (mm)	17.6 (448)
	Net Weight	lbs (kg)	219.14 (99.4)
	Airflow	CFM	4,500
	Sound Pressure	dB(A)	62.9

* Condensing unit above or below indoor unit
For Compatibility See Product Data

Performance

Air Handler	Indoor Model	40MBAAQ48XA3	
	Energy Star	NO	
	Cooling Rated Capacity	Btu/h	48,000
	Cooling Cap. Range Min - Max	Btu/h	12,000~64,000
	SEER	16	
	EER	8.2	
	Heating Rated Capacity (47°F)	Btu/h	55,000
	Heating Rated Capacity (17°F)	Btu/h	36,000
	Heating Maximum Capacity (17°F)	Btu/h	40,900
	Heating Capacity (5°F)	Btu/h	31,500
	Heating Cap. Range Min - Max	Btu/h	13,700~62,700
	HSPF	9.5	
	COP (47°F)	W/W	2.6
	COP (17°F)	W/W	2.3
	COP (5°F)	W/W	2.08

Construction View

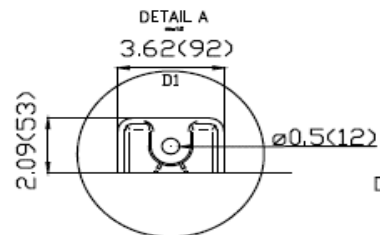
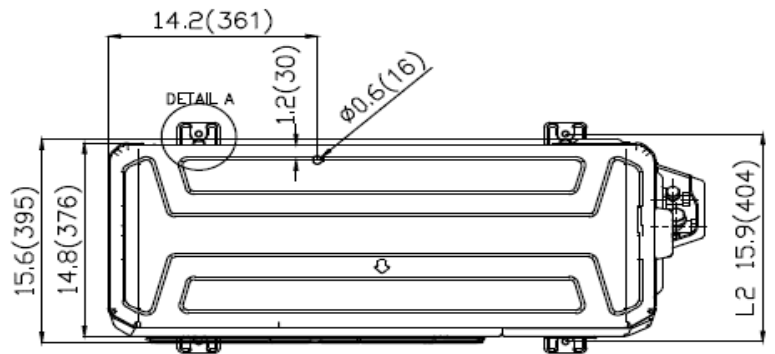
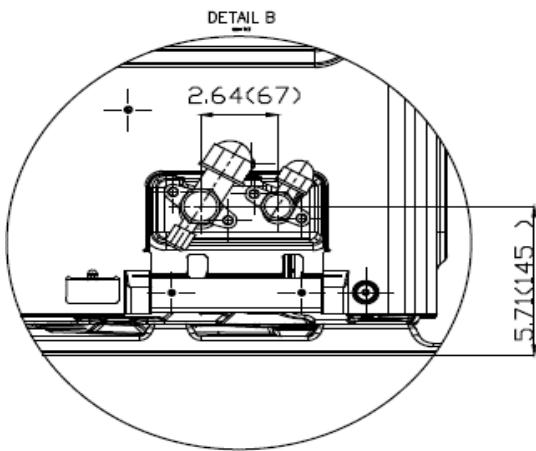
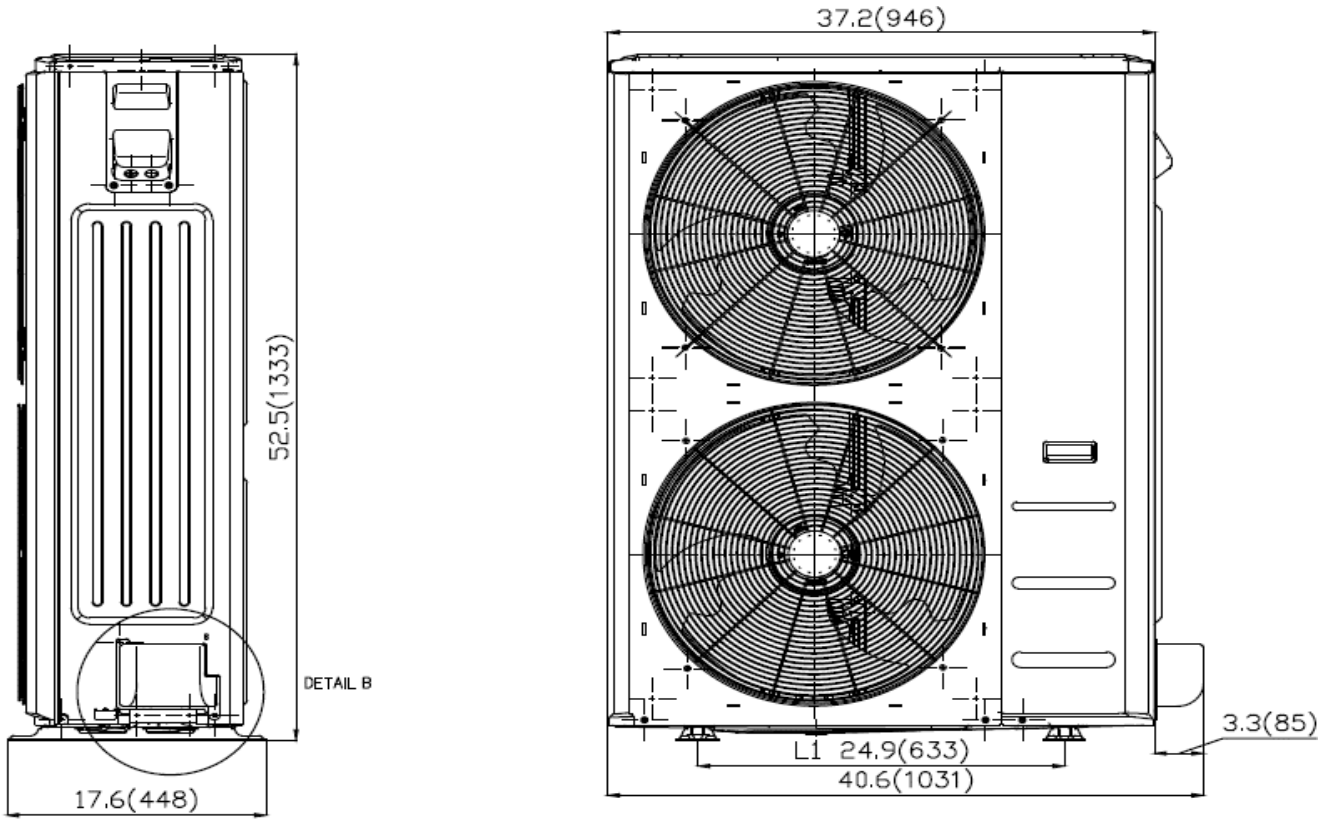

DIMENSIONS IN (MM)



