

Wired Remote Controller
7 Day Programmable Thermostat
Ductless Systems
KSACN0601AAA (High Wall / Console Models)
KSACN0701AAA (Cassette / Ducted / Console)

Installation Instructions



Fig. 1 — Wired Controller

NOTES: Read the entire instruction manual before installing the wired controller.
Images are for illustration purposes only. Actual models may differ slightly.

TABLE OF CONTENTS

	PAGE
SAFETY CONSIDERATIONS.....	3
COMPATIBILITY	5
PREPARATION BEFORE INSTALLATION	6
WIRED CONTROLLER INSTALLATION PRECAUTION.....	7
CONTROLLER DIMENSIONS	7
INSTALLATION	8
APPENDIX 1.....	14
APPENDIX 2.....	22
TROUBLESHOOTING.....	23
SPECIFICATION	24
TECHNICAL INDICATIONS AND REQUIREMENT.....	24

SAFETY CONSIDERATIONS

Read these instructions thoroughly and follow all warnings or cautions included in the literature and attached to the wired controller. Consult local building codes and National Electrical Code (NEC) for special requirements.

Recognize safety information. This is the safety-alert symbol . When you see this symbol on the wired controller and in instructions or manuals, be alert to the potential for personal injury. Understand these signal words: **DANGER**, **WARNING**, and **CAUTION**. These words are used with the safety-alert symbol.

DANGER identifies the most serious hazards which will result in severe personal injury or death. **WARNING** signifies hazards which could result in personal injury or death.

CAUTION is used to identify unsafe practices which may result in minor personal injury or product and property damage. **NOTE** is used to highlight suggestions which will result in enhanced installation, reliability, or operation.



CAUTION

Failure to follow this warning could result in personal injury or death. Before beginning any modification or installation of this kit, ensure the main electrical disconnect is in the **OFF** position. Ensure power is disconnected to the fan coil unit. On some systems both the fan coil and the outdoor unit may be on the same disconnect. Tag the disconnect switch with a suitable warning label. There may be more than one to disconnect.



CAUTION

INSTALLATION

Only the distributor or authorized professionals should install the unit. Installation by unskilled persons may lead to improper installation, electric shock, or fire. Re-installation must be performed by authorized professionals. Non-compliance may lead to electric shock or fire.

NOTES: Save this manual for future reference.

- This manual provides a detailed description of the precautions that the user should be mindful of during operation. Keep this manual, after reading it, for future reference.
- To ensure correct service of the wired controller, read this manual carefully.

NOTES:

- Do not install the wired controller in a location vulnerable to flammable gas leaks. A fire may occur if there is a gas leak around the controller.
- Do not operate with wet hands or allow water to enter the wired controller, otherwise an electric shock may occur.
- The wiring should be a compatible connection cable for the current wired controller. Otherwise, electric leakage or heating may occur and result in a fire.
- Use the specified cables for wiring. Do not allow any external force to be applied to the connection wire terminals. Use this wiring to ensure there is no mechanical damage. Ensure the wire insulation is rated for the temperature it will sustain during operation. Failure to use this wire could result in a fire.

COMPATIBILITY

Table 1 — Compatibility

Indoor Unit Type	Indoor Model Number	KSACN0601AAA	KSACN0701AAA
HIGH WALL	40MPHA	○	
	619PHA	○	
	DHMPHA	○	
	DLFPHA	○	
	40MAQ	○ †	
	619P*B	○ †	
	DHMSHA	○	
	DLFSHA		
	40MHH	○	
	DLFEHA	○	
CASSETTE	40MBQB*C		○
	40MBCQ		○
	DLFSCA		○
	DLFLCA		○
DUCTED	40MBQB*D		○
	40MBDQ		●
	DLFSDA		●
	DLFLDA		●
CONSOLE	40MBQB*F		
	40MBFQ	○ 9 - 12 ‡	○ 18 - 58
	DLFSFA	○ 12	○ 18 - 24
	DLFLFA		○
AIR HANDLER	40MBAA		
	DLFSAA		
	DLFLAA		

○	Optional
●	Standard
	Not Compatible

NOTES:

- + 7 Day programmable compatible with indoor units starting with Serial Number 0216V10001
- ‡ Compatible with indoor units starting with Serial Number 0117V10001
- Units built prior to these serial numbers require a Control Board Replacement on the indoor unit.

PREPARATION BEFORE INSTALLATION

1. Confirm the following required parts have been supplied.

Table 2 — Parts

NO.	NAME	QTY.	REMARKS
1	Wired controller	1	
2	Installation and owner's manual	1	
3	Screws	3	M4X20 (for mounting on the wall)
4	Wall plugs	3	For mounting on the wall
5	Screws	2	M4X25 (for mounting on the switch box)
6	Plastic screw bars	2	For fixing on the switch box
7	Battery	1	CR2032 3 VDC
8	Connection Extension Cable	1	19 feet (6 meters)
9	Adapter Board	1	Required for High Wall 40MAQ/619P*B/DHMPHA Only
10	Display Board	1	Required for High Wall 40MAQ/619P*B/DHMPHA Only
11	EMC Ferrite core (magnetic ring)	1	wrap the wires between the indoor unit and the wired remote controller after installation and around the Ferrite core twice.

NOTES:

Extension wire available through RCD (Replacement Components)

- Part Number: 17401204000769.

2. Prepare the following assemblies on site.

Table 3 — Assemblies

No.	Name	QTY. (Embedded into Wall)	Specification (Only for Reference)	Remarks
1	Switch box	1		
2	Wiring tube (insulating sleeve and tightening screw)	1		

WIRED CONTROLLER INSTALLATION PRECAUTION

1. This manual provides the wired controller installation method. Refer to the wiring diagram (see Fig. 7 — on page 11) for guidance on wiring the wired controller to the indoor unit.
2. The wired controller works in a low voltage circuit (5-12 VDC). **DO NOT** connect directly to any line voltage. Wiring clearance between the configured tubes should range 11.81-19.69 inches (30-50 cm) or above.
3. The shielded wire of the wired controller must be properly grounded.

NOTE: Upon completion of the wired controller connection, do not use any device to test the insulation.

CONTROLLER DIMENSIONS

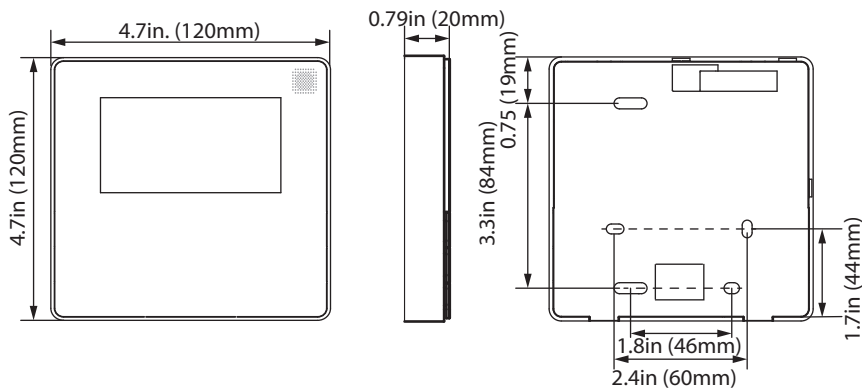

Fig. 2 — Wired remote controller structural dimensions

INSTALLATION

Use the following steps to install the wired controller.

1. Remove the back plate of the wired controller.
2. Insert a flat head screwdriver into the slots in the bottom of the wired controller (2 slots).

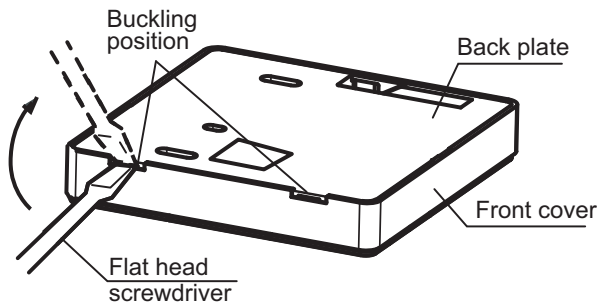

Fig. 3 — Remove the back plate of the wired controller

NOTE: The PCB is mounted to the front cover of the wired controller. Be careful not to damage the board with the screwdriver.

3. For exposed mounting, fasten the back plate on the wall with the 3 screws (M4×20) and plugs.

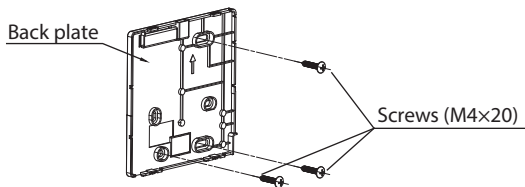

Fig. 4 — Back plate

4. Use two M4X25 screws to install the back plate. Use one M3.9X25 screw to secure to the wall.

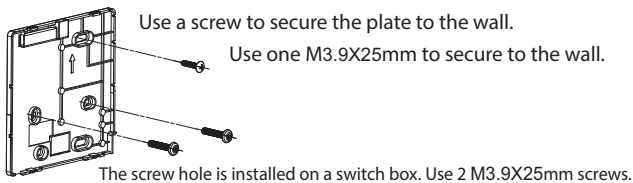

Fig. 5 — Screw to wall

5. Battery Installation:

- a. Place the battery into the installation site and ensure the positive side of the battery is in accordance with the positive side of installation site (see Fig. 6).

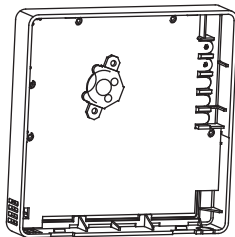

Fig. 6 — Battery Installation

- b. Set the time corrected on the first time operation. Batteries in the wired controller can timeout during a power failure which ensures the time is accurate. When the power restores, if the time displayed is not accurate, the battery is dead and must be replaced.

6. Wiring Instructions:
Follow the indoor unit installation manual for proper connection.

NOTE: See “APPENDIX 1” on page 14 for installation on High Wall 40MAQ/619P*/DHMPHA only.

Use one of the following options to direct the wiring:

- Notch the part for the wiring to pass through with nippers.
- Use the wiring hole on the back of the wired controller.

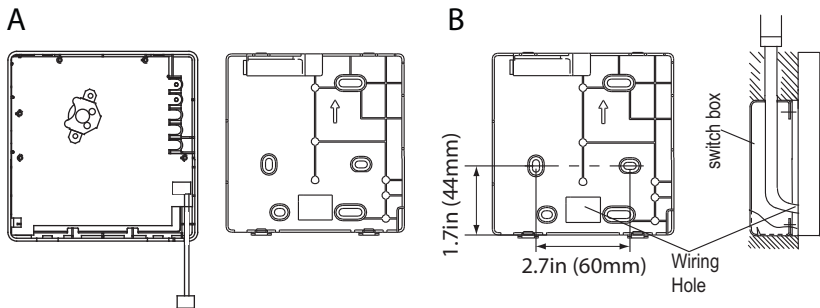

Fig. 7 — Wiring the controller

- Connect the female plug of the wires from the main board with the male plug of the extension wire.
- Connect the other side of the extension wire to the male plug of the wired controller.

- e. Run interconnecting cable from the wired controller to the indoor unit connecting to the PCB board using the quick connects. The included magnetic ring reduces any high frequency noise from the communication wire, which is installed on the connection cable close to the indoor unit (see Fig 8).

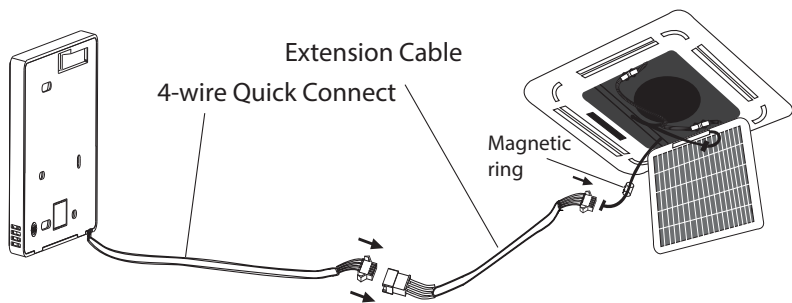

Fig. 8 — 4 - Wire Quick Connect

NOTE: Ensure the length of the connecting cable is long enough for periodic maintenance.

NOTE: DO NOT allow water to enter the wired control. Use a trap and putty to seal the wires (see Fig. 9).

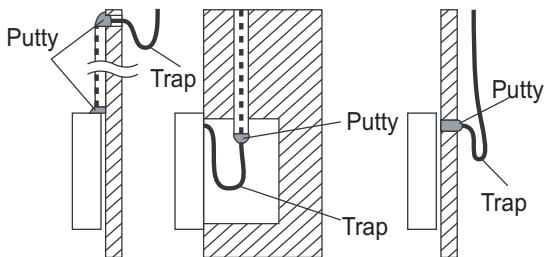

Fig. 9 — Seal the wires

7. Reattaching the Front Cover of the Wired Controller
While adjusting and mounting the front cover, avoid clamping the wiring during installation (see Fig 10).

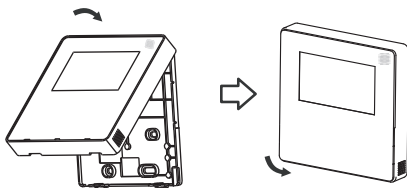

Fig. 10 — Reattaching the Front Cover of the Wired Controller

APPENDIX 1

DISPLAY BOARD AND ADAPTER BOARD INSTALLATION ON 40MAQ/619P*B/DHMPHA HIGH WALL MODELS ONLY

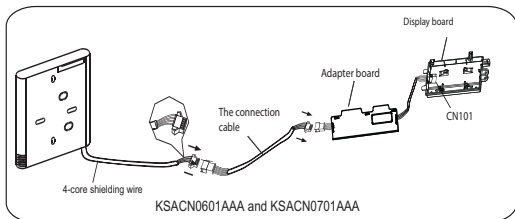

Fig. 11 — Installation of KSACN0601AAA and KSACN0701AAA

1. Install the Adapter Board and the Display Board ONLY on the **High Wall 40MAQ/619P*/DHMPHA**.
2. Connect the female plug of the wires from the main board with the male plug of the extension wire.
3. Next, connect the other side of the adapter board to the display board.
4. Connect the other side of the extension wire to the male plug of the wired controller.

1. Open the front panel.



Fig. 12 — Front Panel

2. Disconnect the wire from the main controller board.



Fig. 13 — Main Controller Board

3. Identify the components shown in Fig. 14 (from left to right; the wired controller, adapter board and the display board).

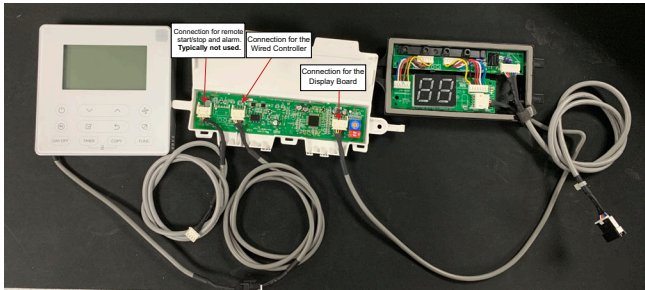

Fig. 14 — Wired Controller, Adapter Board, and Display Board

4. Identify the connections on the Display Board.
- CN201 is the Display Board connection to the main board (on the Display Board).

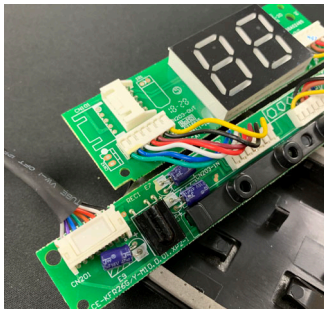

Fig. 15 — CN201 Connection to the Main Control Board

- CN101 is the Display Board connection to the adapter board (on the Display Board).



Fig. 16 — CN101 Connection to the Adapter Board

5. Uninstall the Display Board from the front panel. Keep the Display Board holder.

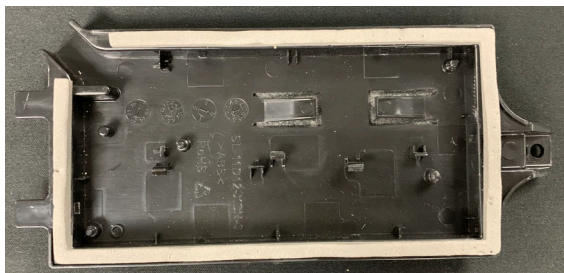

Fig. 17 — Display Board Holder

- Carefully bend and break off the rectangular section (upper left section with two diagonal holes) from the Display Board (see Fig. 18).

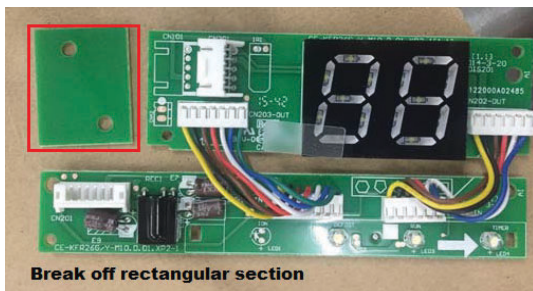

Fig. 18 — Display Board

- Replace the original Display Board with the new Display Board from the kit and secure with the clips. To uninstall the clips, push the clips inward.

NOTE: There are 4 clips just above the numeric display (88) which run the length of the holder.

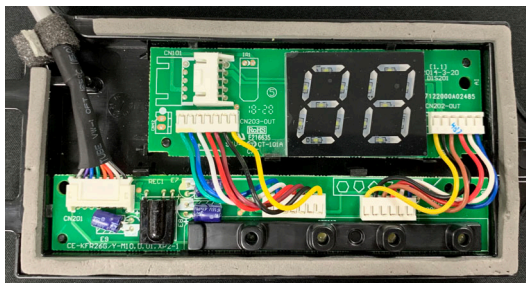

Fig. 19 — Display Board Installed on the Display Board Holder

8. Before re-mounting the display assembly to the front panel of the indoor unit, remove the screen protector on the display.

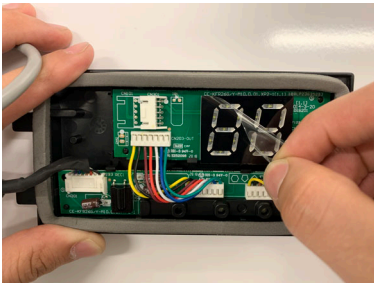

Fig. 20 — Display Board Screen Cover

9. Connect the Wires to the Adapter Board.
- Open the Adapter Board cover and connect the wire coming from the Display Board to the Adapter Board (this connection consists of 5 wires).

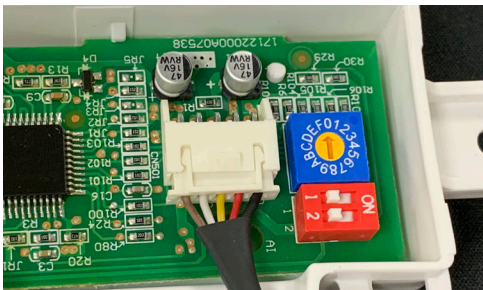

Fig. 21 — Adapter Board to Display Board Connection

- Connect the wire coming from the Wired Controller to the Adapter Board (this connection consists of 4 wires).

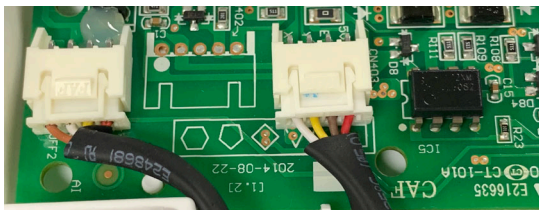

Fig. 22 — Wired Controller Port

- Once the ports are connected, close the cover.



Fig. 23 — Adapter Board

- Mount the new Display Board and Adapter board to the Front Panel.
- Connect the wired controller to the Adapter board.



Fig. 24 — Front Panel with New Display Board and Adapter Board

- Connect the wire from the Main Control board. see Fig. 25 — on page 22.

APPENDIX 2

INSTALLATION of KSACN0601AAA for CONSOLE INDOOR MODELS (SIZES 9-12)

1. Locate the net module connected to CN20 on the Main Control Board (see Fig. 25).

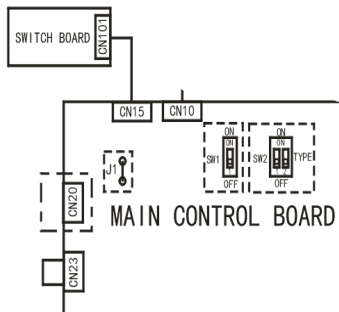

Fig. 25 — Main Control Board

2. Connect the wired control with the net module (see Fig. 26).

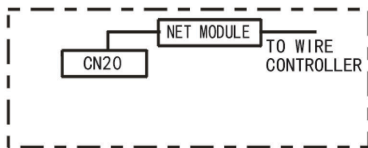

Fig. 26 — Net Module

TROUBLESHOOTING

For ease of service, the systems are equipped with diagnostic code display LEDs on the Wired Remote Controller, indoor and outdoor units. The indoor diagnostic display is a combination of flashing LEDs on the display panel or the front of the unit.

Some indoor units display error codes specifying failure modes in the outdoor units. If possible, always check the diagnostic codes displayed on the indoor unit first. The diagnostic codes displayed in the indoor and wired remote controller are listed in Table 4.

Table 4 — Troubleshooting

DISPLAY ON IDU	DISPLAY ON PROGRAMMABLE WIRED CONTROLLER	INDOOR UNIT ERROR CODE DEFINITION
N/A	F0	Communication error between wired controller and indoor unit
N/A	F1	The cassette faceplate is abnormal
E0	E7	Indoor unit EEPROM error
E1	E1	Communication error between indoor unit and outdoor units
E3	E8	Indoor fan speed error
E4	E2	Indoor Return air temperature sensor error
E5	E3	Indoor coil temperature sensor error
EC	EF	Low refrigerant
EE	EE	High water level alarm
E8	EF	Communication error in twins system (not available)
E9	EF	One unit failure in twins system (not available)
F1	E5	Outdoor ambient temperature sensor error
F2	E5	Outdoor coil temperature sensor error
F3	E5	Compressor discharge temperature sensor error
F4	Ed	Outdoor unit EEPROM error
F5	Ed	Outdoor unit fan speed error
F6	E4	Indoor coil outlet temperature sensor error
FA	EF	Communication error
PD	Eb	Inverter module IPM error
P7	EF	Outdoor IGBT temperature sensor error

SPECIFICATION

Table 5 — Specification

INPUT	KSACN0601AAA: DC 5V KSACN0701AAA: DC 12V
Ambient temperature	23~110F (-5~43C)
Ambient humidity	RH40%~RH90%

Table 6 — Wiring Specifications

WIRING TYPE	SIZE	MAXIMUM LENGTH
Sheathed vinyl cord or cable	0.029 in - 0.74mm (0.75 - 1.25mm ²)	KSACN0601AAA: 66 ft (20m)
		KSACN0701AAA: 164 ft (50m)

TECHNICAL INDICATIONS AND REQUIREMENT

EMC and EMI comply with the CE certification requirements.