

**50ZPB, C, 50ZHB, C,
PA3Z-A, PH3Z-A, PA4Z, PH4Z,
PAJ4, PHJ4, WJA4, WJH4**

**SMALL PACKAGED PRODUCTS (SPP)
Accessory Electric Heaters 5–20 kW
For 14 SEER, R-410A
Manufactured Home**

Installation Instructions

NOTE: The Dual Point Kit can only be installed on units equipped with a 2nd electrical entry (knockout), the knockout was added to the electrical panel starting with the following unit serial numbers:

2711X_____ and later

X1127_____ and later

NOTE: Read the entire instruction manual before starting the installation.

NOTE: Installation Instructions include Single and Dual point connection instructions separately.

SAFETY CONSIDERATIONS

Improper installation adjustment, alteration, service, maintenance, or use can cause explosion, fire, electrical shock, or other conditions which may cause death, personal injury, or property damage. Consult a qualified installer, service agency, or your distributor or branch for information or assistance. The qualified installer or agency must use factory-authorized kits or accessories when modifying this product Refer to the individual instructions packaged with the kits or accessories when installing.

Follow all safety codes. Wear safety glasses, protective clothing, and work gloves. Use quenching cloth for brazing operations. Have a fire extinguisher available. Read these instructions thoroughly and follow all warnings or cautions included in literature and attached to the unit. Consult local building codes, the current editions of the National Electrical Code (NEC) NFPA 70.

In Canada refer to the current editions of the Canadian Electrical Code CSA C22.1.

Recognize safety information. This is the safety-alert symbol . When you see this symbol on the unit and in instructions or manuals, be alert to the potential for personal injury. Understand these signal words; DANGER, WARNING, and CAUTION. These words are used with the safety-alert symbol. DANGER identifies the most serious hazards which **will** result in severe personal injury or death. WARNING signifies hazards which **could** result in personal injury or death. CAUTION is used to identify unsafe practices which **may** result in minor personal injury or product and property damage. NOTE is used to highlight suggestions which **will** result in enhanced installation, reliability, or operation.

Before proceeding with heater installation, inspect thoroughly for shipping damage. Notify shipper immediately if any damage is found. Clean all dirt, dust and moisture from heater package.

Check for proper clearances of live parts, between phases and to ground. Make sure that all required barriers are in place. Check conductors run in multiple to insure that they are properly wired. Refer to unit installation instructions for complete unit installation details. The minimum air quantity for safe electric heater operation is shown in Table 2.

WARNING

ELECTRICAL SHOCK HAZARD

Failure to follow this warning could result in personal injury or death.

Before performing installation, service or maintenance operations on this system, turn off all main power to system. There may be more than one disconnect switch. Turn off accessory heater power switch if applicable. Lock out and tag switch with a suitable warning label.

DESCRIPTION AND USAGE

These heaters are comprised of a separate heater module mounted on the blower inlet and remote mounted controls located in the unit control box. Heater models are provided with single point electrical connections for powering both the heater and the unit.

These heaters are intended for use only in SPP units as noted in Table 1.

PACKAGE CONTENTS

Electric Heater Package Contents

1. Heater assembly, comprised of heater module and control panel
2. UPC heater label
3. Installation Instructions
4. Identification label
5. Wiring label
6. Wire connectors (2)
7. Wire ties-6" (5)
8. Screws #10B (4)
9. Ground lug (1) (See Fig. 8)
10. Bolts 3/8-16 (3)
11. Plug attachment plate
12. Dual Point Electric Rating Label
13. Dual Point Warning Label

INSTALLATION

Single Point Heater Installation

1. Open all electrical disconnects and install lock-out tag before beginning any installation or service work.
2. Check for proper heater application in Table 1.
3. Remove unit side panel to access blower compartment (See Fig. 1 and Fig. 2).
4. Disconnect wiring to motor by removing speed selection and power plugs from bottom of motor (See Fig. 2).
5. Remove rear blower support bracket. Remove shipping block and label under blower if unit has one (See Fig. 2).
6. Remove screws securing blower to front blower support bracket; slide blower out of unit.

Table 1 – Electric Heater Usage Chart

CPHEATER	Agency Approval	kW	V	PH	Circuit Breaker	Air Conditioner Models (PAC)						Heat Pump Models (PHP)					
						24	30	36	42	48	60	24	30	36	42	48	60
125	UL	5	208/240	1	N	√	√	√	√	√	√	√	√	√	√		
126	UL	5	208/240	1	Y	√	√	√	√	√	√	√	√	√	√	√	√
127	UL	7.5	208/240	1	N	√	√	√	√	√	√	√					
128	UL	7.5	208/240	1	Y	√	√	√	√	√	√	√	√	√	√	√	√
129	UL	10	208/240	1	N	√	√	√	√	√							
130	UL	10	208/240	1	Y	√	√	√	√	√	√	√	√	√	√	√	√
131	UL	15	208/240	1	Y			√	√	√	√			√	√	√	√
132	UL	20	208/240	1	Y					√	√					√	√

Table 2 – Minimum Airflow for Heater Operation

Air Conditioner Unit Size	Minimum Airflow (CFM)				
	5 kW	7.5 kW	10 kW	15 kW	20 kW
24	600	750	750	X	X
30	600	750	750	X	X
36	600	750	750	1050	X
42	600	750	750	1050	X
48	600	750	750	1050	1400
60	600	750	750	1050	1400

X= Not Approved Combination

Heat Pump Unit Size	Minimum Airflow (CFM)				
	5 kW	7.5 kW	10 kW	15 kW	20 kW
24	750	800	800	X	X
30	750	800	800	X	X
36	750	800	800	1200	X
42	750	800	800	1200	X
48	750	800	800	1200	1700
60	750	800	800	1200	1700

X= Not Approved Combination

- Open heater package and remove heater module; secure heater module to standoffs on blower inlet with (3) bolts provided (see Fig. 3). Adjust mounting position so that all hardware and sheetmetal clears the heating element wire by at least 1/4 in. Reinstall heater/blower assembly.
- Reinstall rear motor support bracket and attached motor wiring. Reinsert motor power plug and speed tap plug into motor. The connectors are polarized to prevent mis-wiring.
- Remove heater wiring cover plate from interior partition between blower and control box (See Fig. 4) and install heater wiring plug attachment plate provided with heater.
- Remove unit front panel to access unit control box compartment.
- Open heater package and remove heater control panel; set heater control panel on top of unit (See Fig. 5).
- Heater control panel will have black and yellow power wires ending in panel mounted plugs; reach through large rectangular opening in control panel and snap these plugs into mating openings in heater wiring plug attachment plate installed in step 9 above (See Fig. 4).
- Rotate heater control panel into unit control box area and locate it into top left corner of control box; secure heater control panel to unit control box with (4) screws provided (See Fig. 6).
- Open flexible “fishpaper” insulation cover provided with unit control box and route heater low voltage wires along the bottom of the unit control box. Route low voltage leads from heater relay(s) through hole in unit control box and into low voltage splice box. (See Fig. 6 and Fig. 7.) dress wires and secure them to existing unit control wires with wire ties provided .
- Re-close flexible “fishpaper” insulation cover; insure unit black and yellow power “pigtailed” from contactor are properly routed through insulation cover (See Fig. 8).
- Attach the adhesive backed wiring label provided with the heater to the back of the access panel near the unit wiring label (See Fig. 1).
- Return to blower compartment and locate black and yellow power wires from heater module; these wires will terminate in plug connectors that mate with the plug from the heater control installed in Step 13 above. Snap these connectors into place; dress and secure wires to fan wires with wire ties provided (See Fig. 9).
- The factory speed tap for electric heat operation is tap 2. Refer to blower performance table in the unit installation instructions or pre-sale literature to determine available airflow at duct system external static pressure. Compare the actual airflow with the minimum required airflow from Table 2. If tap 2 airflow is lower than minimum required airflow, recheck blower performance table to see if minimum airflow can be achieved on tap 3. If tap 3 airflow meets the minimum CFM requirement, change speed tap for electric heat from tap 2 to tap 3 in unit control box. See unit instructions and wiring diagram. If tap 3 airflow does not achieve minimum CFM requirement, then another electric heater that meets the minimum CFM requirement must be used.
- Reattach the blower access panel.

CPHEATER

Table 3 – Electric Heater Part Number Information

CPHEATER	Diagram	kW @		V / PH / Hz			Amps		Power Connection		24v Unit Control Wiring			KW Staging				
		208	240	V	PH	Hz	208	240	Term Block	Circuit Breaker	No. Stages	Comm (Brown)	W2 (White)	W3 (Violet)	Stage-1	Stage-2		
125A02	111002853	3.75	5	208/230	1	60	18	20.8	X	--	1	X	X	--	5kw	--		
126A02	111002854	3.75	5				18	20.8	--	X	--	X	1	X	X	--	5kw	--
127A02	111002855	5.6	7.5				27	31.3	X	--	X	--	1	X	X	--	7.5kw	--
128A02	111002856	5.6	7.5				27	31.3	--	X	--	X	1	X	X	--	7.5kw	--
129A02	111002857	7.5	10				36.1	41.7	X	--	X	--	1	X	X	--	10kw	--
130A02	111002858	7.5	10				36.1	41.7	--	X	--	X	1	X	X	--	10kw	--
131A02	111002859	11.3	15				54.1	62.5	--	X	--	X	2	X	X	X	5kw	10kw
132A02	111002860	15	20				72.1	83.3	--	X	--	X	2	X	X	X	10kw	10kw

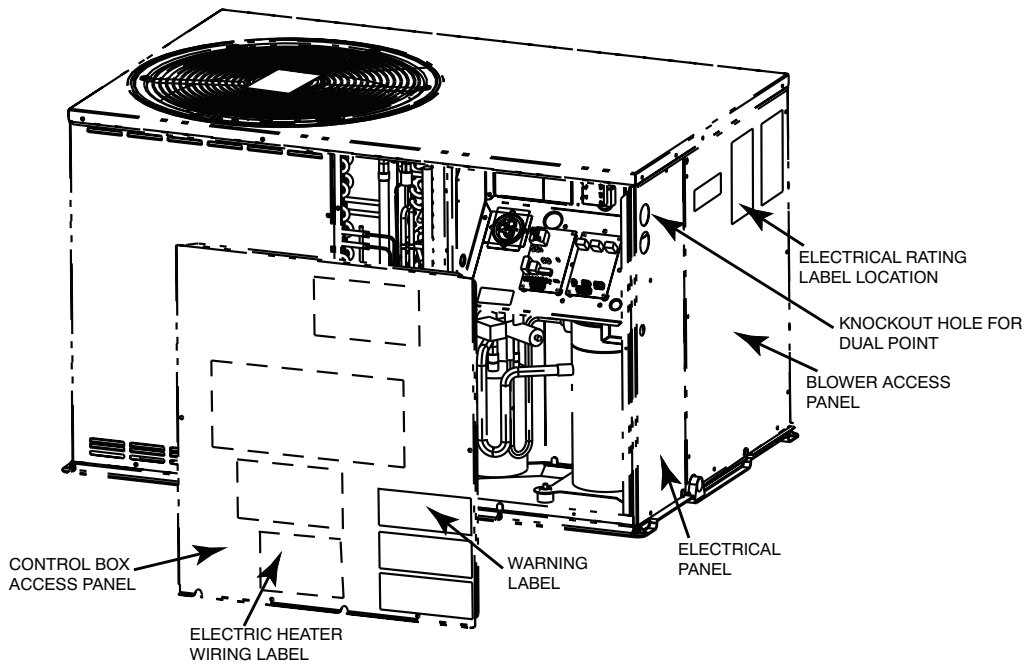

Fig. 1 - Access Panel and Label Location

A11167

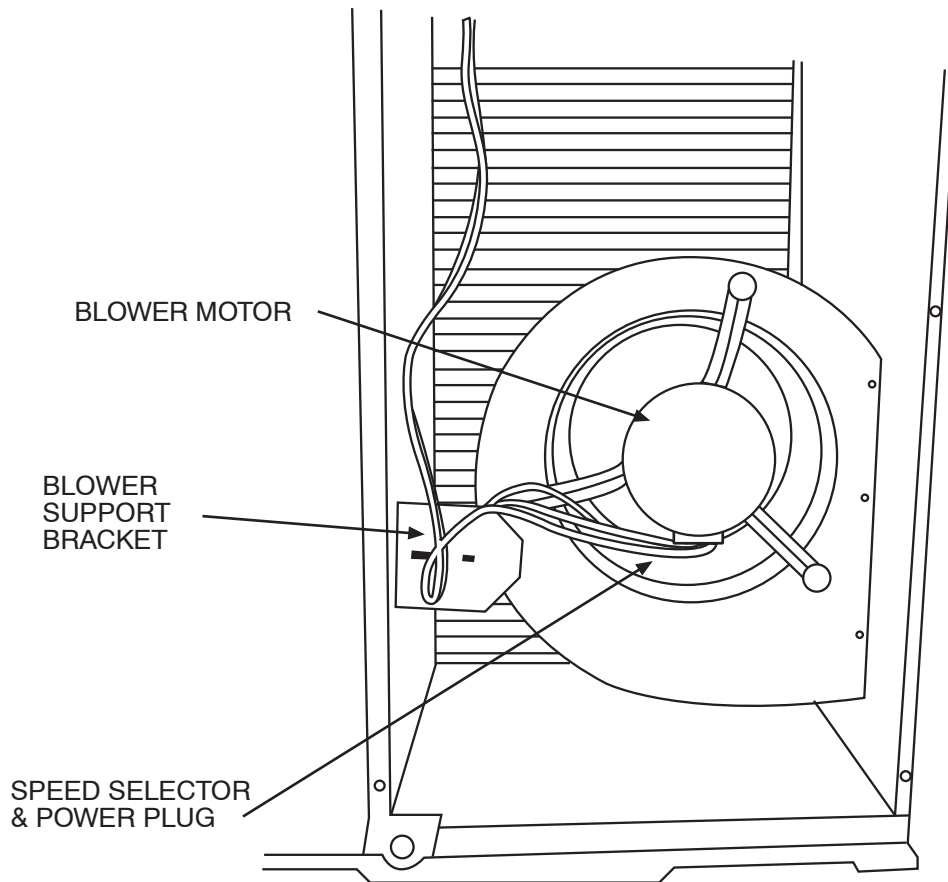

Fig. 2 - Indoor Blower Compartment

A05382

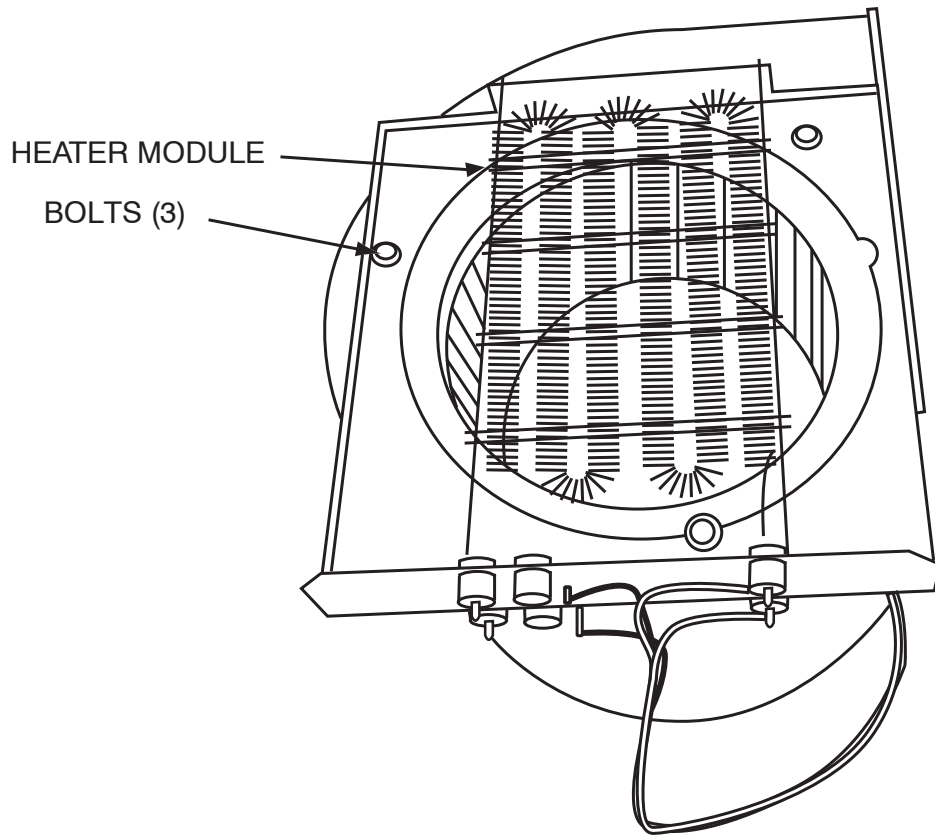

Fig. 3 - Attach Heater Module

A10111

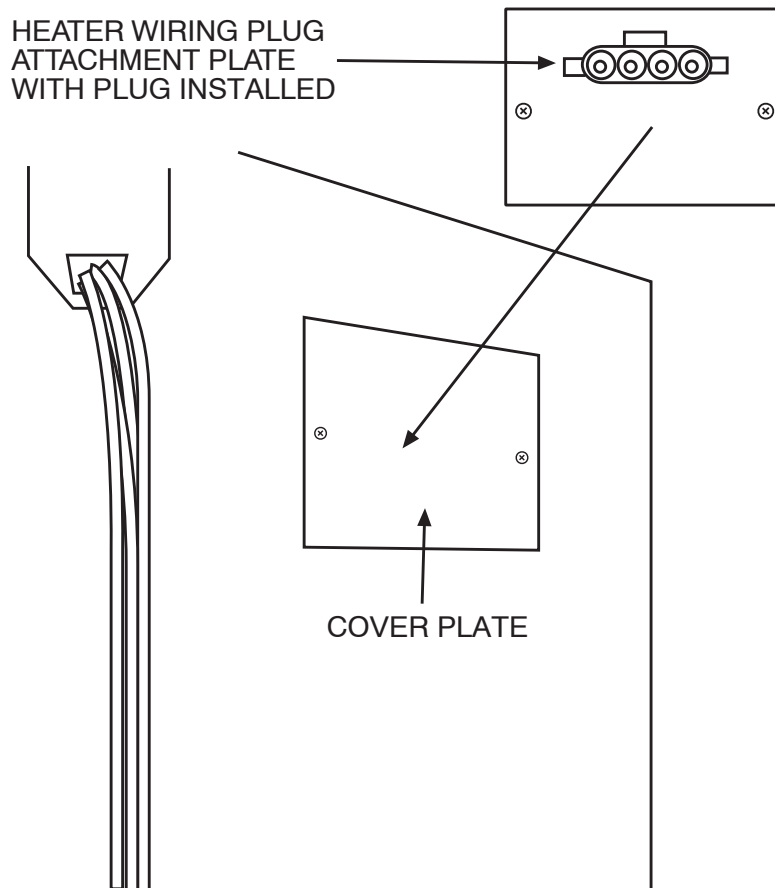

Fig. 4 - Inside Blower Compartment

A05384

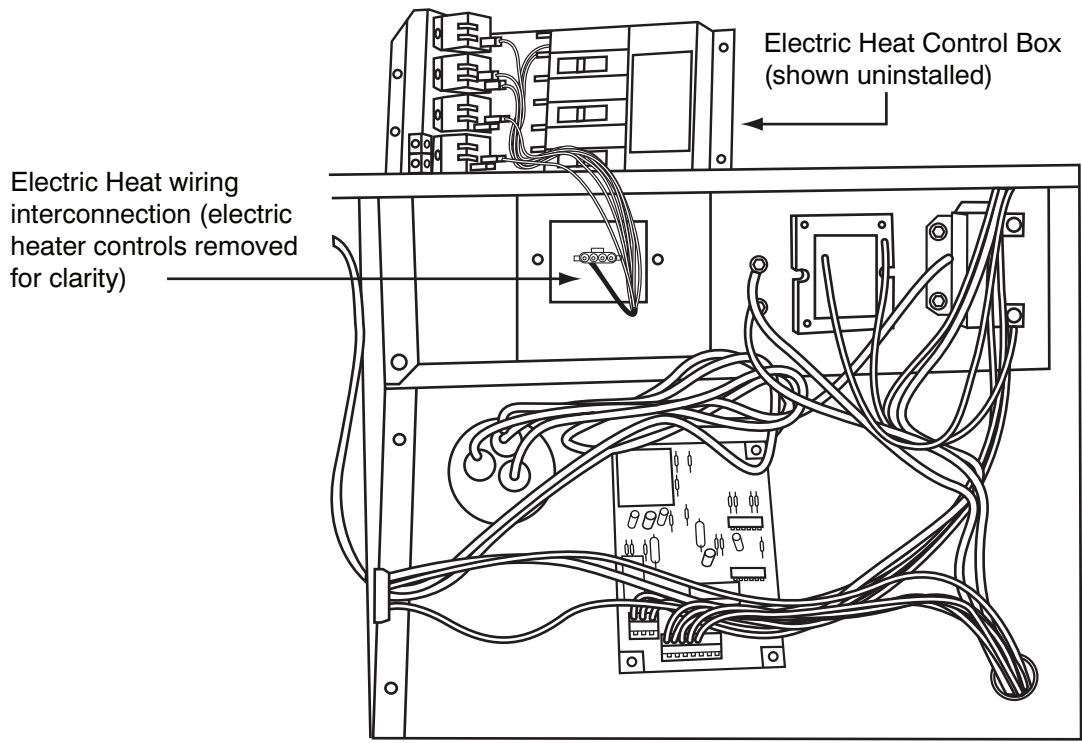

Fig. 5 - Unit Control Box Compartment

A10031

HEATER CONTROL PANEL MOUNTING SCREWS (4)

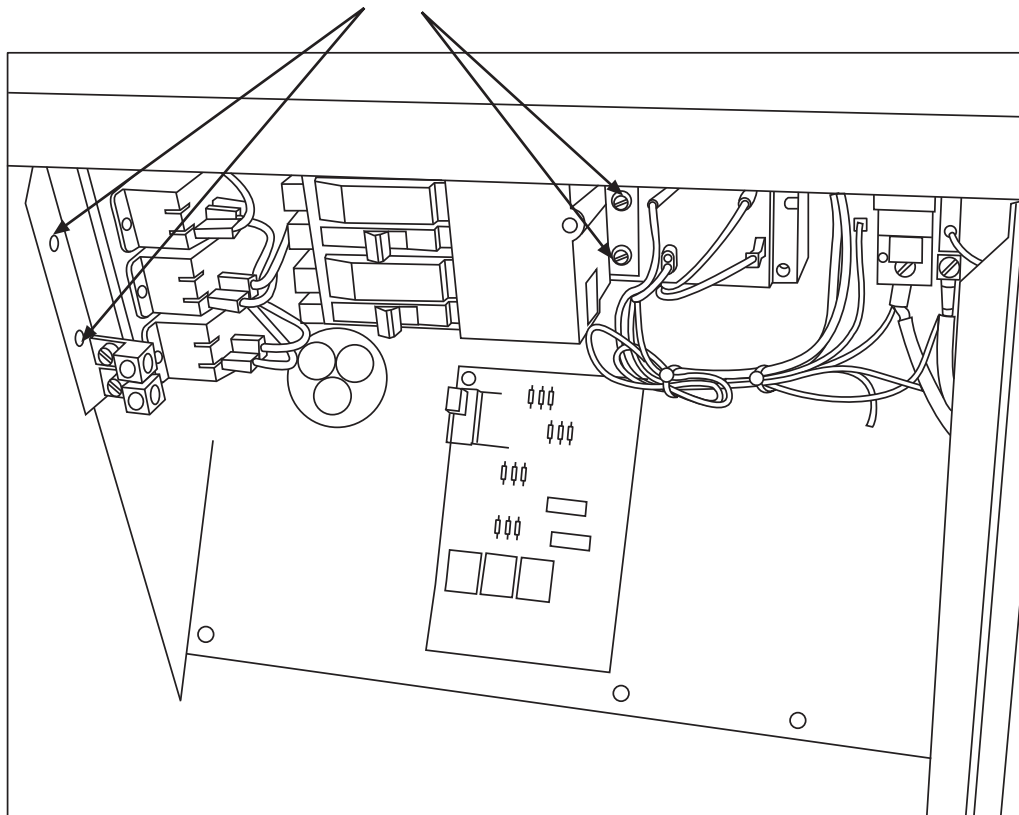
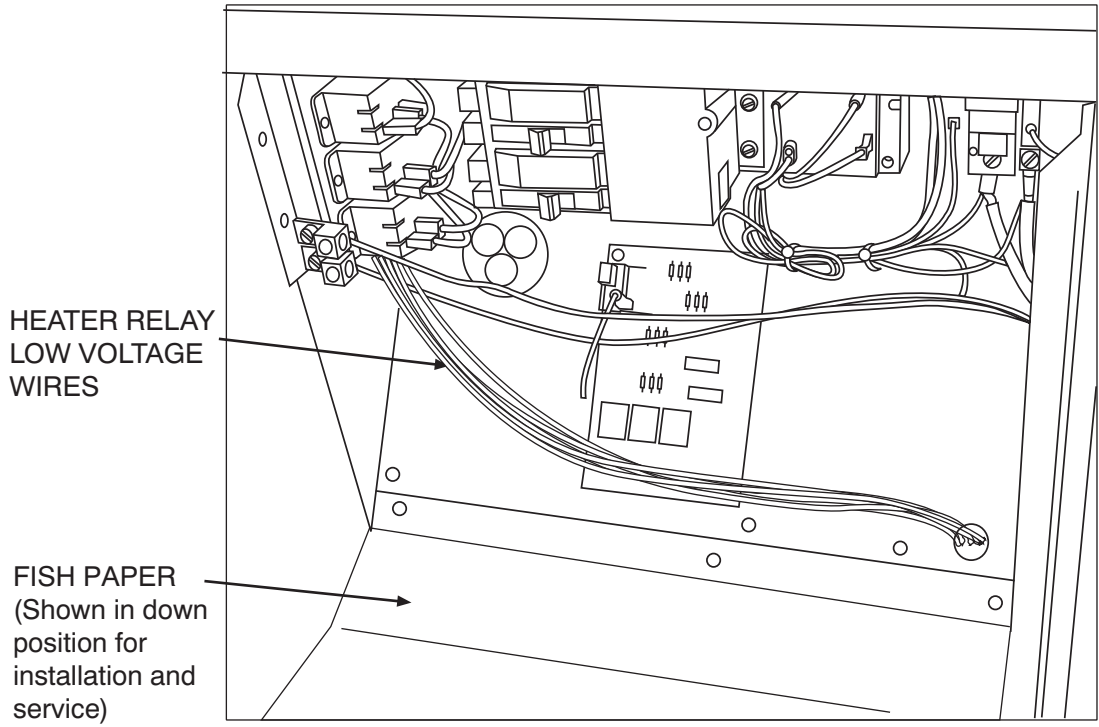

Fig. 6 - Heater Control Panel Installation

A10119



A10120

Fig. 7 - Heater Low Voltage Connection

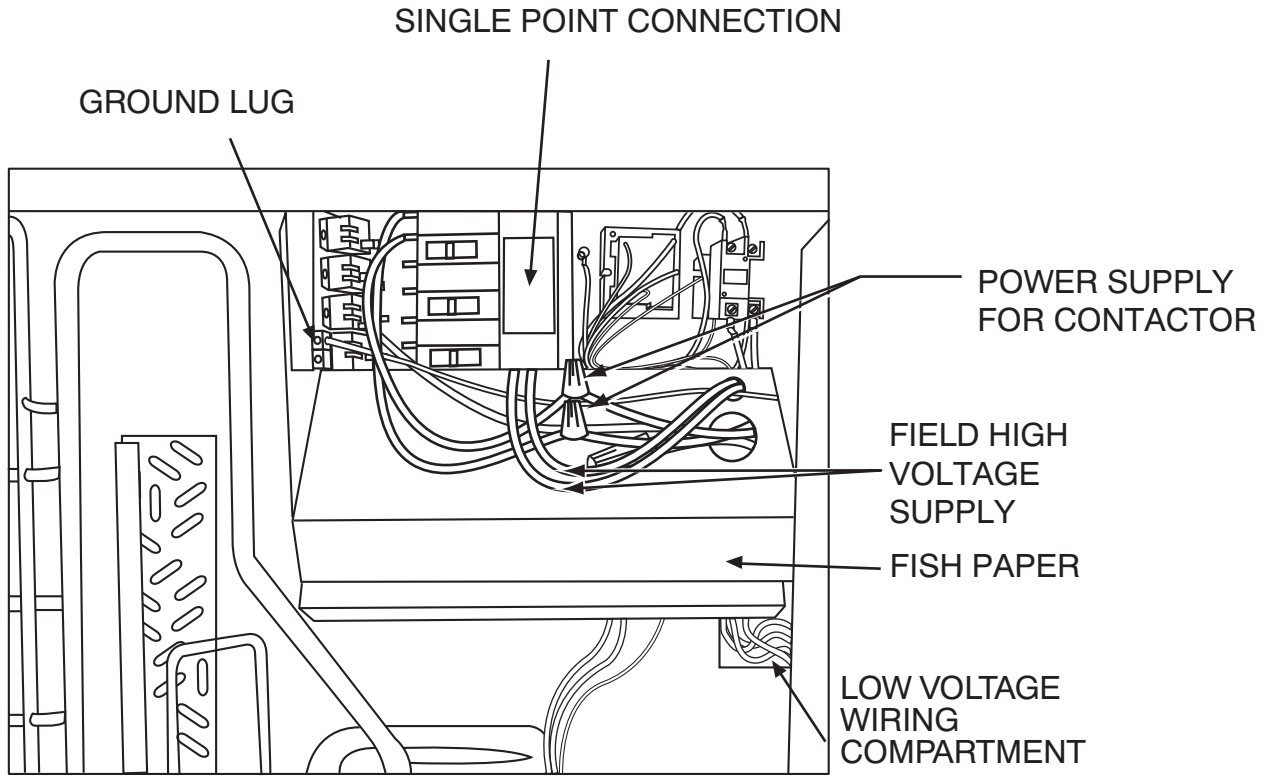

A10121

Fig. 8 - Unit Power Connection

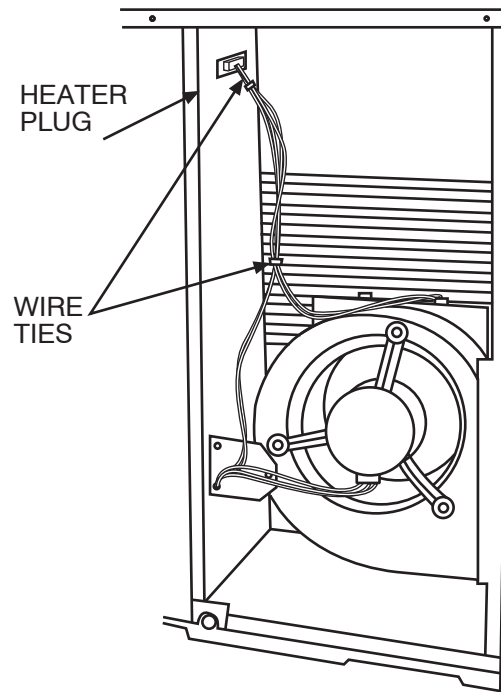

Fig. 9 - Power Connection to Heater

A05385

Single Point Electrical Connection

NOTE: All electrical connections, wire sizes and type of conduit shall meet the National Electric Code (NEC) and state and local codes (or International Electric Code) as applicable.

NOTE: Use minimum 75°C copper wire only.

1. Make sure all disconnects are still open and tagged out as required previously.
2. Mark the main unit nameplate with an "X" for the electric heater size being installed. Refer to the electrical data marked with an "X" on the nameplate for wire and maximum over current protection sizing.
3. Connect low voltage wires as shown in unit schematic diagrams found on the base unit installation instructions. These connections must be made in the 24v barrier section inside the unit panel (See Fig. 10 or Fig. 11).
4. Insert field power line through the Electrical Panel hole (see Fig. 10 or Fig. 11) and connect to electric heater as shown in their respective wiring diagram. Electrical heaters with factory installed circuit breakers must have their field lines connected to the breaker block lugs and electric heater without factory installed circuit breakers must have their field lines connected to the heater leads using wire nuts. Ground electrical equipment in the appropriate locations.

IMPORTANT: Heaters with factory installed circuit breakers may be installed on a branch circuit protected by either a fuse or circuit breaker. For all other heaters, the branch circuit must be protected by a fuse or circuit breaker supplied by others.

5. Connect black and yellow stripped wires from heater to the unit compressor contactor leads using supplied wire nuts according to their heater wiring diagram.

NOTE: Dress wires with wire ties provided. Separate all wires from incoming power leads.

6. Close control box access panel.

Dual Point Heater Installation

NOTE: Complete single point heater installation procedures before completing the following steps.

1. Open all electrical disconnects and install lockout tag before beginning any installation or service work.
2. Remove Control Box Access Panel (see Fig. 1), check for clearance on the inside of control box, and remove a 7/8-in knockout hole on the Electrical Panel for second power line.
3. Attach warning and rating labels in the selected location (see Fig. 1).
4. Mark the main unit nameplate with an "X" next to the accessory heater "none". Mark the dual point rating label installed at step 3 with an "X" for the electrical heater size being installed. Refer to the electrical data marked with an "X" on each nameplate for wire and maximum over current protection sizing.
5. Remove unit power wiring line connection from heater to unit contactor and compressor leads as shown in heater wiring diagram. These are the stripped end wires black and yellow, with opened ends.

Dual Point Electrical Connection

NOTE: All electrical connections, wire sizes and type of conduit shall meet the national Electric Code (NEC) and state and local codes (or International Electric Code) as applicable.

NOTE: Use a minimum 75°C copper wire only.

1. Make sure all disconnects are still open and tagged out as required previously.
2. Connect low voltage wires as shown in unit schematic diagrams found on base unit installation instructions. These connections must be made in the 24v barrier section inside the unit panel (see Fig. 12 or Fig. 13).
3. Insert first field power line through the Electrical Panel bottom hole (see Fig. 12 or Fig. 13) and connect to electric heater as shown in their respective wiring diagram found on the heater accessory kit. Electrical heaters with factory installed circuit breakers must have their field lines connected to the breaker block lugs and electric heater without factory installed circuit breakers must have their field lines connected to the heater leads using wire nuts. Ground electrical equipment in the appropriate locations.

IMPORTANT: Heaters with factory installed circuit breakers may be installed on a branch circuit protected by either a fuse or circuit breaker. For all other heaters, the branch circuit must be protected by a fuse or circuit breaker supplied by others.

NOTE: Dress wires with wire ties provided. Separate all wires from incoming power leads.

4. Insert second field power line through the Electrical Panel top hole (see Fig. 12 or Fig. 13) and connect to unit contactor black and yellow leads using wire nuts. Ground electrical equipment in the appropriate locations.
5. Separate all wires from incoming power leads.
6. Close electrical access panel.

START-UP

⚠ CAUTION

ELECTRICAL SHOCK HAZARD

Failure to follow this caution may result in personal injury or death.

Before proceeding, verify that all wiring is correct per factory approved schematic. Notify equipment supplier immediately of any discrepancies.

NOTE: Relay, Rectifier and Time Delay Boards

Each heater element is controlled by a 24VDC control relay. Each control relay is energized by a small rectifier board attached directly to relay coil terminals. When possible - one rectifier board is used to control a second relay.

The rectifier board converts incoming 24v AC control signal to DC. Some heaters may have up to four relays. The second and/or third relay rectifier board may also have a time delay feature and a small jumper wire built into it. With the jumper uncut, the time delay is approximately 5 sec after the initial first stage. When jumper is cut at factory, this provides an 8 sec delay.

1. Refer to base unit installation instructions as required.
2. Check for loose terminal connections.
3. Check that all fuse and circuit breaker short circuit interrupting ratings are adequate.
4. Turn on unit and heater power.
5. Set thermostat to call for heat.
6. Check operation of heater.
7. Check that airflow across the heater is at or above the minimum recommended CFM requirement (See Table 2).
8. Use of accessory electric heaters that are not tested and approved by the original equipment manufacturer of the packaged air conditioner or heat pump is not recommended and will not be warranted by the original equipment manufacturer. Additionally, damage caused by such heaters to the equipment will not be covered under warranty by the original equipment manufacturer.

TROUBLESHOOTING

1. Circuit Breakers-Malfunction will interrupt power to the unit. Check for cause of failure, reset or replace.
2. Limit Switch-Malfunction prevents heating element(s) from being energized. Replace switch if malfunction occurs.
3. Relay-Malfunction will not allow heater to energize. Replace faulty relay. Do not attempt to repair.

CPHEATER

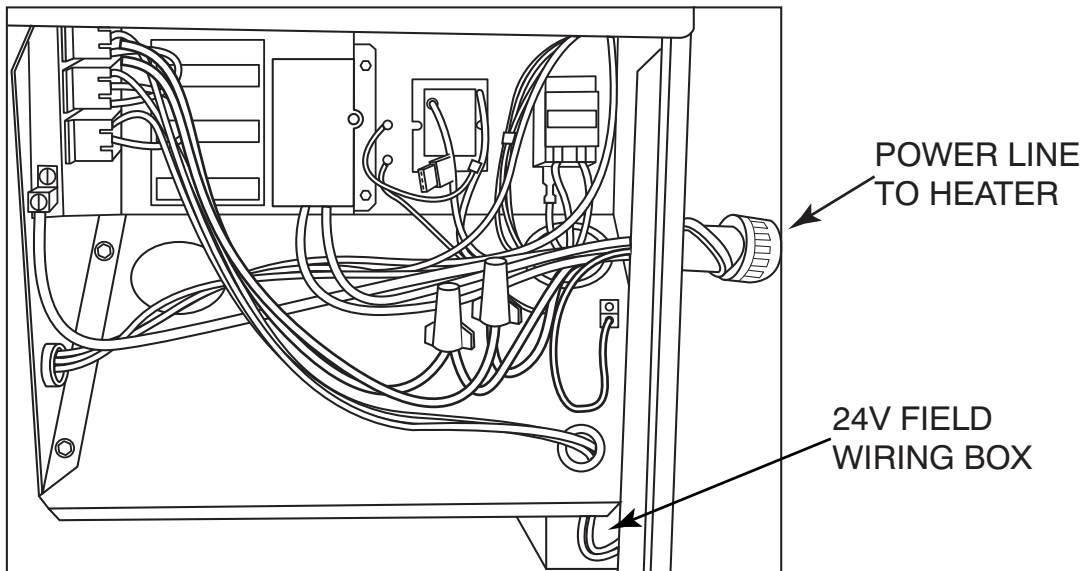

Fig. 10 - Single Point Connections For Heaters With Circuit Breakers

A10381

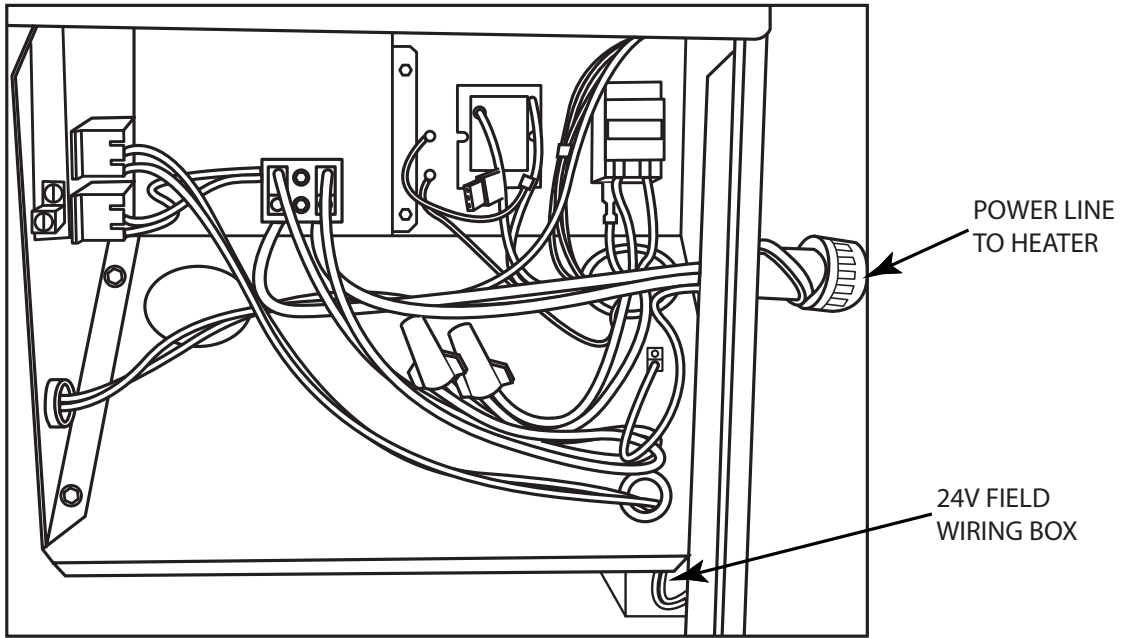

Fig. 11 - Single Point Connections For Heaters Without Circuit Breakers

A10380

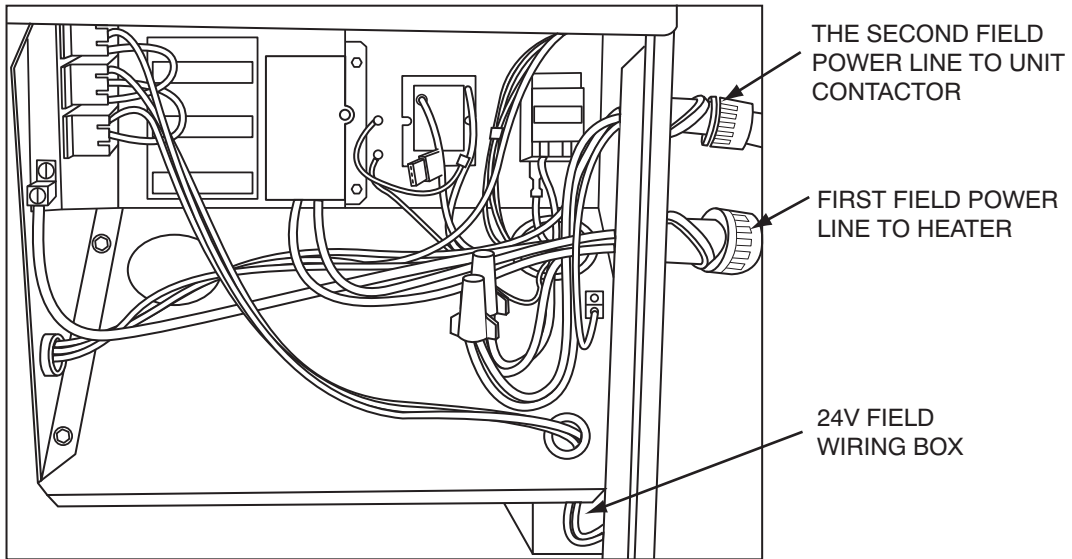

Fig. 12 - Dual Point Connections For Heater With Circuit Breaker

A10379

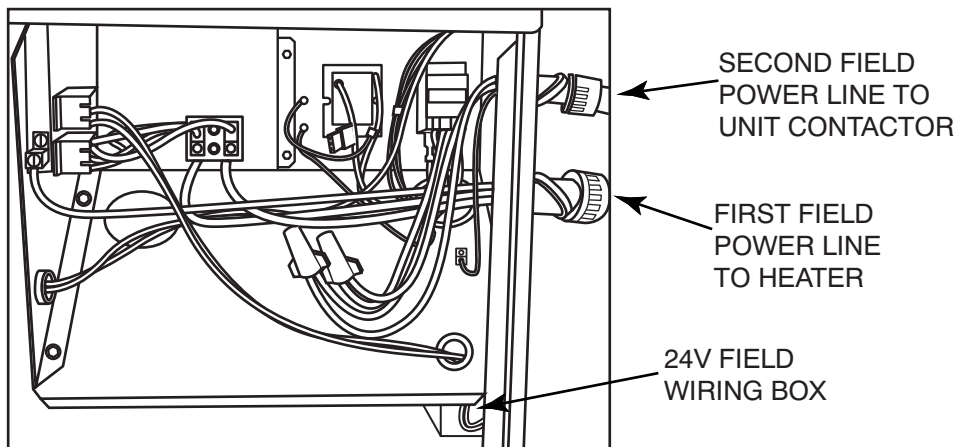
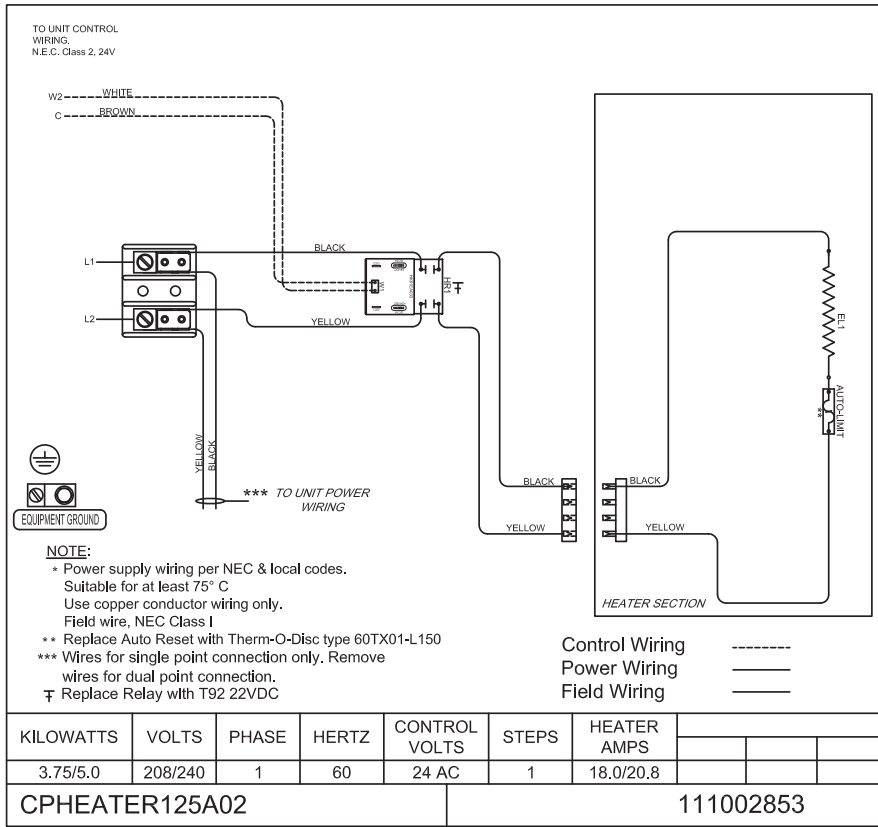

Fig. 13 - Dual Point Connections For Heaters Without Circuit Breakers

A10382



Stick on label included with kit. See Installation Section, Step 17 (Page 2).

Fig. 14 - CPHEATER125A02 Wiring Diagram

A14458

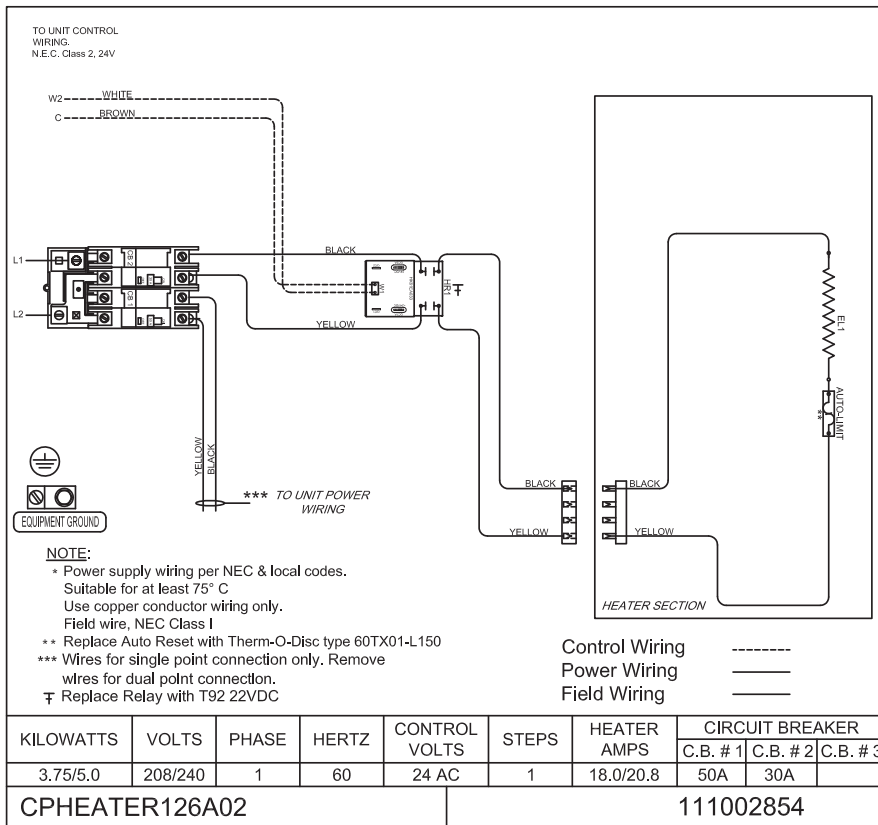

Stick on label included with kit. See Installation Section, Step 17 (Page 2).

Fig. 15 - CPHEATER126A02 Wiring Diagram

A14459

CPHEATER

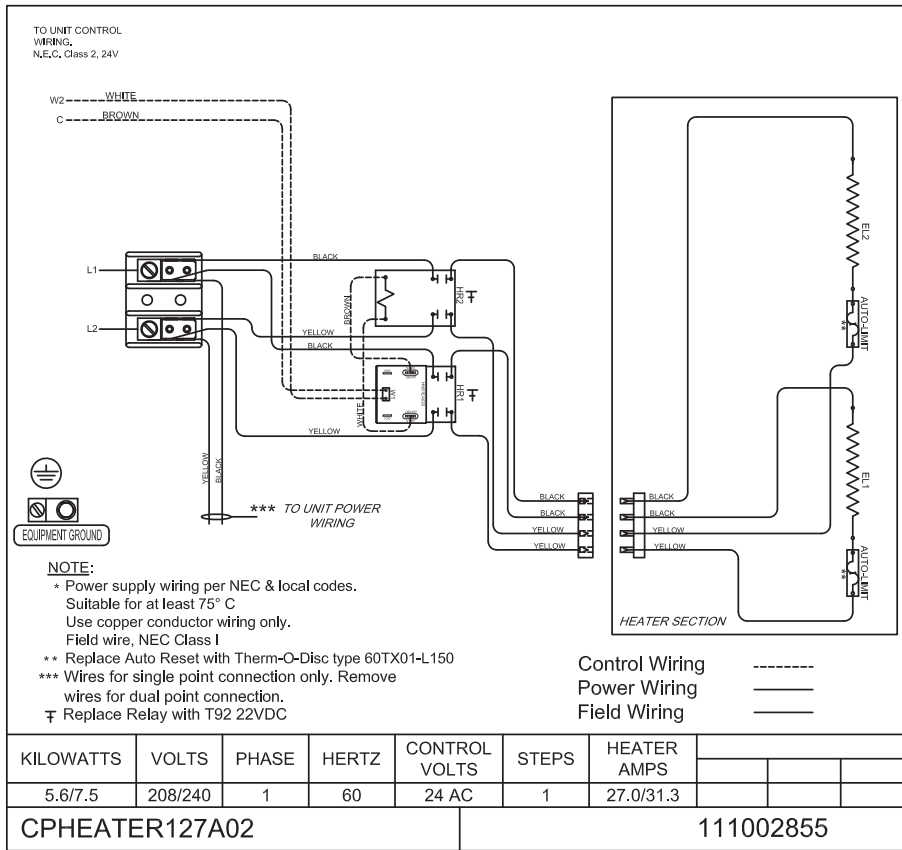

Stick on label included with kit. See Installation Section, Step 17 (Page 2).

Fig. 16 - CPHEATER127A02 Wiring Diagram

A14460

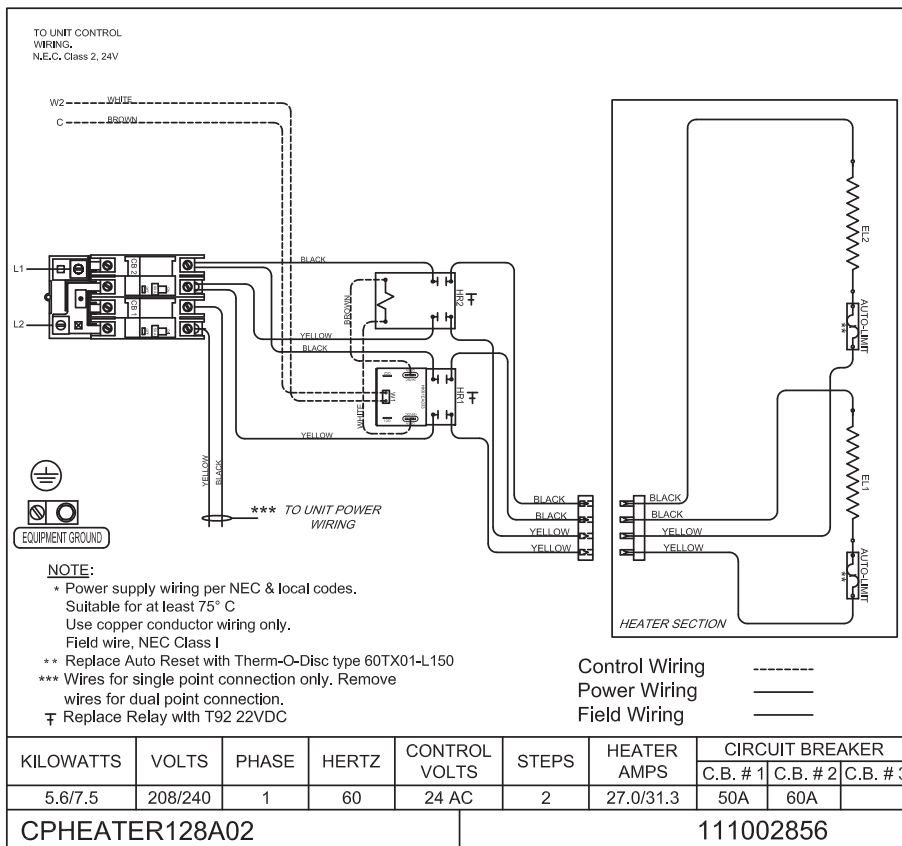

Stick on label included with kit. See Installation Section, Step 17 (Page 2).

Fig. 17 - CPHEATER128A02 Wiring Diagram

A14461

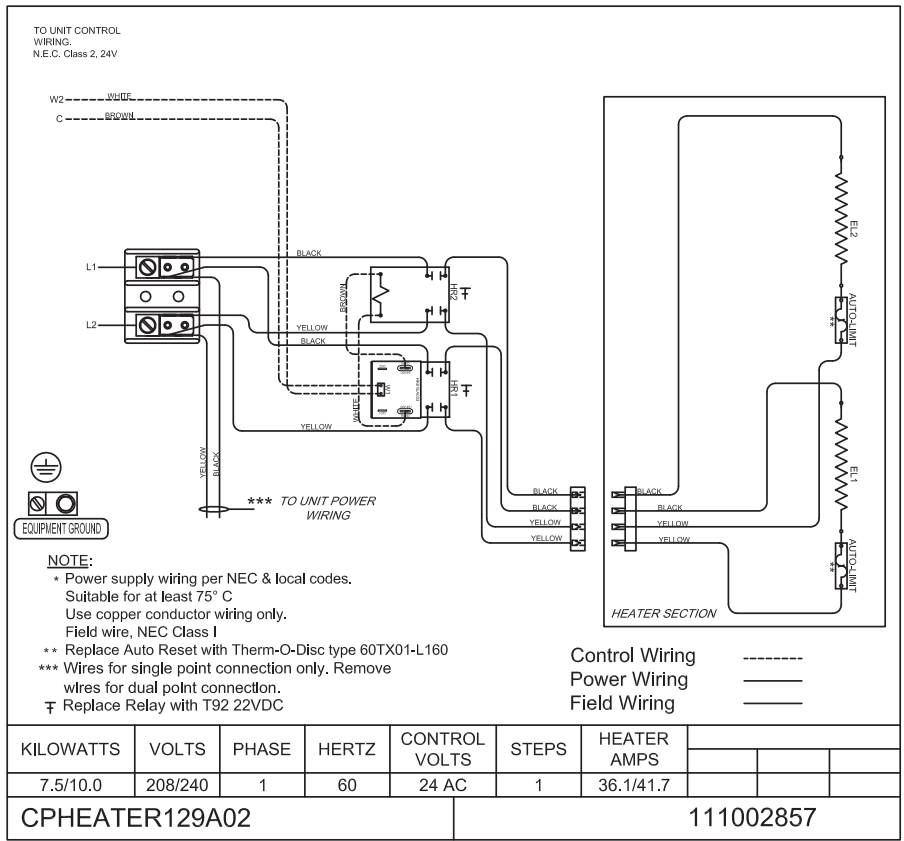

Stick on label included with kit. See Installation Section, Step 17 (Page 2).

Fig. 18 - CPHEATER129A02 Wiring Diagram

A14462

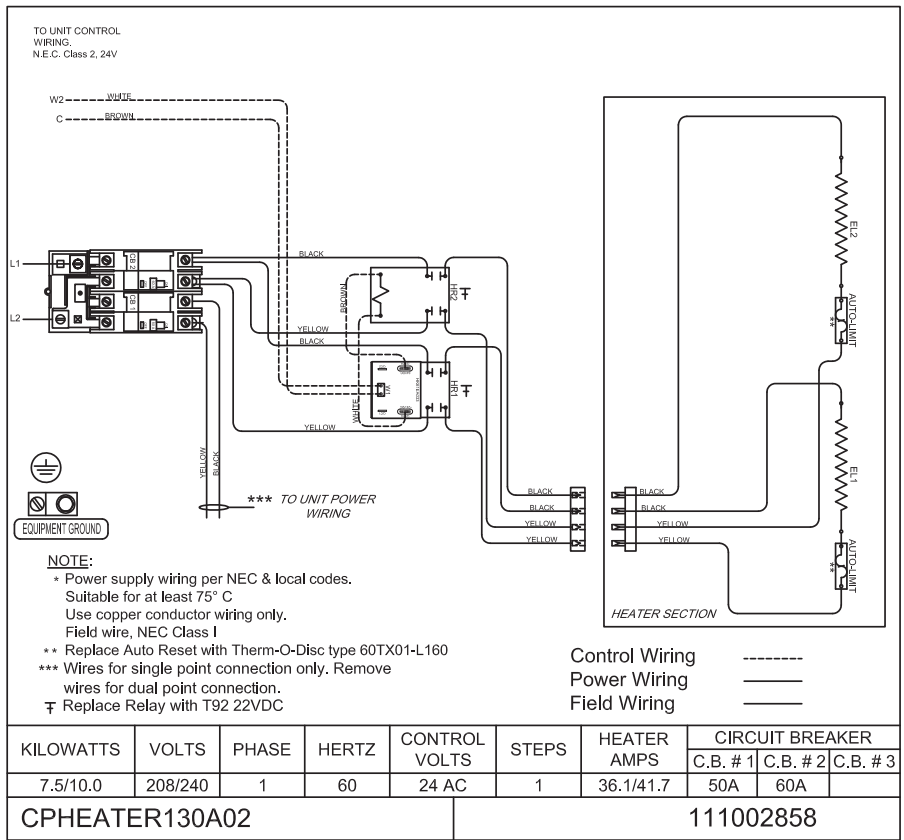

Stick on label included with kit. See Installation Section, Step 17 (Page 2).

Fig. 19 - CPHEATER130A02 Wiring Diagram

A14463

CPHEATER

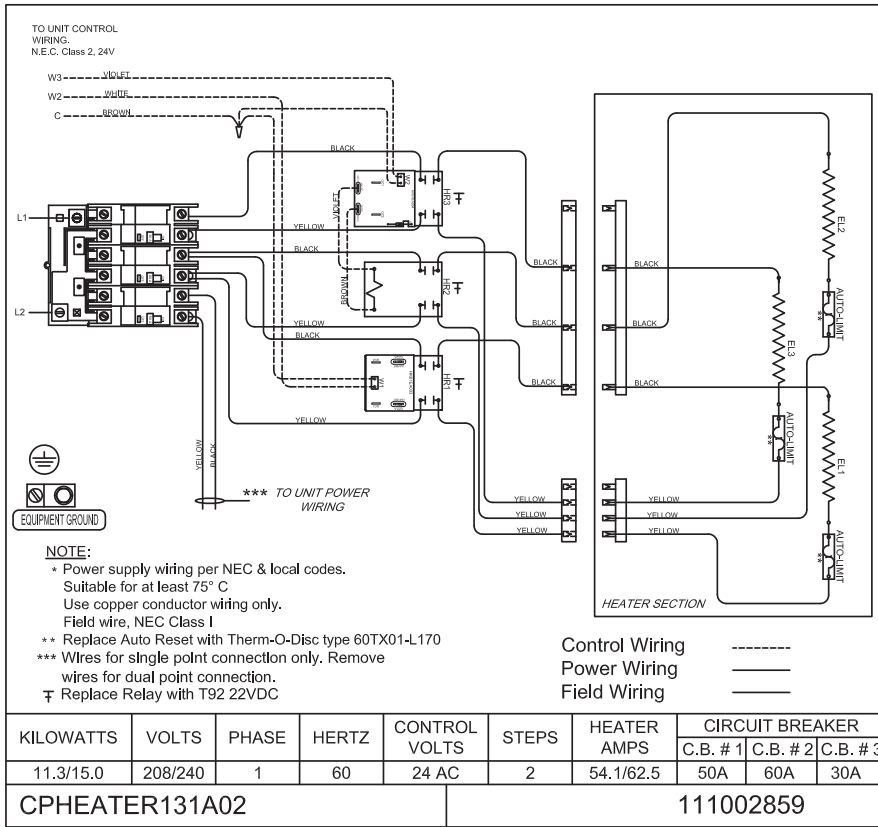

Stick on label included with kit. See Installation Section, Step 17 (Page 2).

Fig. 20 - CPHEATER131A02 Wiring Diagram

A14464

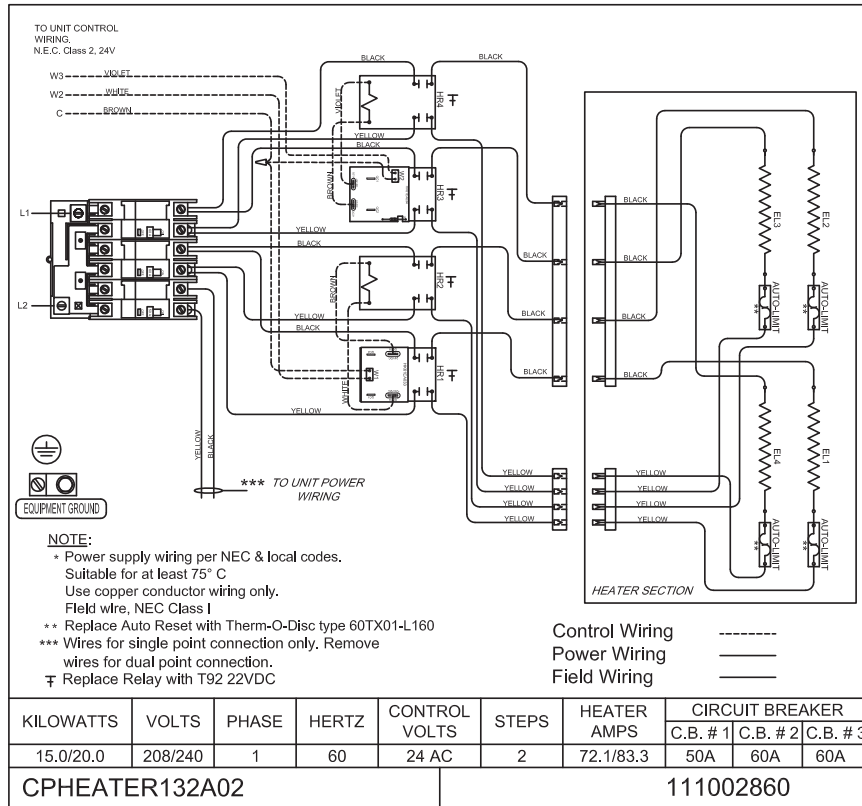

Stick on label included with kit. See Installation Section, Step 17 (Page 2).

Fig. 21 - CPHEATER132A02 Wiring Diagram

A14465