



Installation Instructions

CONTENTS

	Page
SAFETY CONSIDERATIONS	1
MODEL NUMBER NOMENCLATURE AND DIMENSIONS	2
Rated Indoor Airflow	2
INSTALLATION	8
Job Site Survey	8
Step 1 — Plan for Unit Location	9
• ROOF MOUNT	
Step 2 — Plan for Sequence of Unit Installation	9
• CURB-MOUNTED INSTALLATION	
• PAD-MOUNTED INSTALLATION	
• FRAME-MOUNTED INSTALLATION	
Step 3 — Inspect Unit	9
Step 4 — Provide Unit Support	9
• ROOF CURB MOUNT	
• SLAB MOUNT (HORIZONTAL UNITS ONLY)	
• ALTERNATE UNIT SUPPORT (IN LIEU OF CURB OR SLAB MOUNT)	
Step 5 — Field Fabricate Ductwork	11
• UNITS WITH ACCESSORY ELECTRIC HEATERS	
Step 6 — Rig and Place Unit	11
Step 7 — Convert to Horizontal and Connect Ductwork (when required)	12
Step 8 — Install Outside Air Hood	13
• ECONOMIZER HOOD REMOVAL AND SETUP	
• TWO-POSITION DAMPER HOOD REMOVAL AND SETUP	
• ECONOMIZER AND TWO-POSITION HOOD ASSEMBLY	
Step 9 — Units with Hinged Panels Only	14
Step 10 — Install External Condensate Trap and Line	14
Step 11 — Make Electrical Connections	15
• FIELD POWER SUPPLY	
• UNITS WITHOUT FACTORY-INSTALLED DISCONNECT	
• UNITS WITH FACTORY-INSTALLED DISCONNECT	
• ALL UNITS	
• CONVENIENCE OUTLETS	
• FACTORY-OPTION THRU-BASE CONNECTIONS (ELECTRICAL CONNECTIONS)	

- UNITS WITHOUT THRU-BASE CONNECTIONS (ELECTRICAL CONNECTIONS)
- FIELD CONTROL WIRING
- THERMOSTAT
- HEAT ANTICIPATOR SETTINGS
- COMMERCIAL DEFROST CONTROL
- ELECTRIC HEATERS
- CONTROL AND POWER WIRING DIAGRAMS
- ECONOMISER (FACTORY OPTION)
- SMOKE DETECTORS
- RTU OPEN CONTROLLER (FACTORY OPTION)
- CONTROLLER OPTIONS
- Step 12 — Adjust Factory-Installed Options** . . . 45
- SMOKE DETECTORS
- ECONOMISER IV OCCUPANCY SWITCH
- Step 13 — Install Accessories**
 45 || **Step 14 — Check Belt Tension** | 47 |
| • BELT FORCE — DEFLECTION METHOD | |
| • BELT TENSION METHOD | |
| **Pre-Start and Start-Up** | 47 |
| **Typical Unit Piping** | 47 |
| **START-UP CHECKLIST** | CL-1 |

SAFETY CONSIDERATIONS

Improper installation, adjustment, alteration, service, maintenance, or use can cause explosion, fire, electrical shock or other conditions which may cause personal injury or property damage. Consult a qualified installer, service agency, or your distributor or branch for information or assistance. The qualified installer or agency must use factory-authorized kits or accessories when modifying this product. Refer to the individual instructions packaged with the kits or accessories when installing.

Follow all safety codes. Wear safety glasses and work gloves. Use quenching cloths for brazing operations and have a fire extinguisher available. Read these instructions thoroughly and follow all warnings or cautions attached to the unit. Consult local building codes and appropriate national electrical codes (in USA, ANSI/NFPA70, National Electrical Code (NEC); in Canada, CSA C22.1) for special requirements.

It is important to recognize safety information. This is the safety-alert symbol . When you see this symbol on the unit and in instructions or manuals, be alert to the potential for personal injury.

Understand the signal words DANGER, WARNING, CAUTION, and NOTE. These words are used with the safety-alert symbol. DANGER identifies the most serious hazards which **will** result in severe personal injury or death. WARNING signifies hazards which **could** result in personal injury or death. CAUTION is used to identify unsafe practices,

which **may** result in minor personal injury or product and property damage. NOTE is used to highlight suggestions which **will** result in enhanced installation, reliability, or operation.

⚠ WARNING

ELECTRICAL SHOCK HAZARD

Failure to follow this warning could cause personal injury or death.

Before performing service or maintenance operations on unit, turn off main power switch to unit and install lock(s) and lockout tag(s). Ensure electrical service to rooftop unit agrees with voltage and amperage listed on the unit rating plate. Unit may have more than one power switch.

⚠ WARNING

UNIT OPERATION AND SAFETY HAZARD

Failure to follow this warning could cause personal injury, death and/or equipment damage.

Puron® (R-410A) refrigerant systems operate at higher pressures than standard R-22 systems. Do not use R-22 service equipment or components on Puron refrigerant equipment.

⚠ WARNING

PERSONAL INJURY AND ENVIRONMENTAL HAZARD

Failure to follow this warning could cause personal injury or death.

Relieve pressure and recover all refrigerant before system repair or final unit disposal.

Wear safety glasses and gloves when handling refrigerants. Keep torches and other ignition sources away from refrigerants and oils.

⚠ WARNING

CUT HAZARD

Failure to follow this caution may result in personal injury.

Sheet metal parts may have sharp edges or burrs. Use care and wear appropriate protective clothing, safety glasses and gloves when handling parts and servicing air conditioning equipment.

MODEL NUMBER NOMENCLATURE AND DIMENSIONS

See Fig. 1 for 50HCQ model number nomenclature. See Figures 2 and 3 for unit dimensional drawings. Figure 4 shows service clearance dimensions.

Rated Indoor Airflow

Table 1 lists the rated indoor airflow used for the AHRI efficiency rating for the units covered in this document.

Table 1 — Rated Indoor Airflow

MODEL NUMBER	RATED INDOOR AIRFLOW (CFM)
50HCQA07	2400
50HCQD07	2400
50HCQD08	3000
50HCQD09	3400

Position:	1	2	3	4	5	6	7	8	9	10	11	12	13	14	15	16	17	18
Example:	5	0	H	C	Q	D	0	8	A	1	A	6	-	0	B	2	A	0

Unit/Series/Model
50HCQ - Packaged Rooftop Heat Pump

Refrig. Systems Options
A - One Stage Cooling Models
D - Two Stage Cooling Models

Cooling Tons
07 - 6 ton
08 - 7.5 ton
09 - 8.5 ton

Sensor Options
A - None
B - RA Smoke Detector
C - SA Smoke Detector
D - RA + SA Smoke Detector
E - CO₂
F - RA Smoke Detector and CO₂
G - SA Smoke Detector and CO₂
H - RA + SA Smoke Detector and CO₂

Indoor Fan Options
1 - Standard Static Option – Belt Drive
2 - Medium Static Option – Belt Drive
3 - High Static Option – Belt Drive

Coil Options (Outdoor - Indoor - Hail Guard)
A - Al/Cu - Al/Cu
B - Precoat Al/Cu - Al/Cu
C - E-coat Al/Cu - Al/Cu
D - E-coat Al/Cu - E-coat Al/Cu
E - Cu/Cu - Al/Cu
F - Cu/Cu - Cu/Cu
M - Al/Cu -Al/Cu — Louvered Hail Guard
N - Precoat Al/Cu - Al/Cu — Louvered Hail Guard
P - E-coat Al/Cu - Al/Cu — Louvered Hail Guard
Q - E-coat Al/Cu - E-coat Al/Cu — Louvered Hail Guard
R - Cu/Cu - Al/Cu — Louvered Hail Guard
S - Cu/Cu - Cu/Cu — Louvered Hail Guard

Voltage
1 - 575/3/60
5 - 208-230/3/60
6 - 460/3/60

Packaging Options
0 - Standard
1 - LTL

Electrical Options
A - None
C - Non-Fused Disconnect
D - Thru-The-Base Connections
F - Non-Fused Disconnect and Thru-The-Base Connections
G - 2-Speed Indoor Fan (VFD) Controller
J - 2-Speed Indoor Fan (VFD) Controller and Non-Fused Disconnect
K - 2-Speed Indoor Fan (VFD) Controller and Thru-The-Base Connections
M - 2-Speed Indoor Fan (VFD) Controller with Non-Fused Disconnect and Thru-The-Base Connections

Service Options
0 - None
1 - Unpowered Convenience Outlet
2 - Powered Convenience Outlet
3 - Hinged Panels
4 - Hinged Panels and Unpowered Convenience Outlet
5 - Hinged Panels and Powered Convenience Outlet

Intake / Exhaust Options
A - None
B - Temperature Economizer w/ Barometric Relief
F - Enthalpy Economizer w/ Barometric Relief
K - 2-Position Damper
U - Temperature Ultra Low Leak Economizer w/ Barometric Relief
W- Enthalpy Ultra Low Leak Economizer w/ Barometric Relief

Base Unit Controls
0 - Electro-mechanical Controls can be used with W7212 EconoMiSer® IV (Non-Fault Detection and Diagnostic)
1 - PremierLink™ Controller
2 - RTU Open Multi-Protocol Controller
6 - Electro-mechanical with W7220 Economizer controller Controls. Can be used with W7220 EconoMiSer X (with Fault Detection and Diagnostic)

Design Revision
- = Factory Design Revision

Fig. 1 — 50HCQ07-09 Model Number Nomenclature (Example)

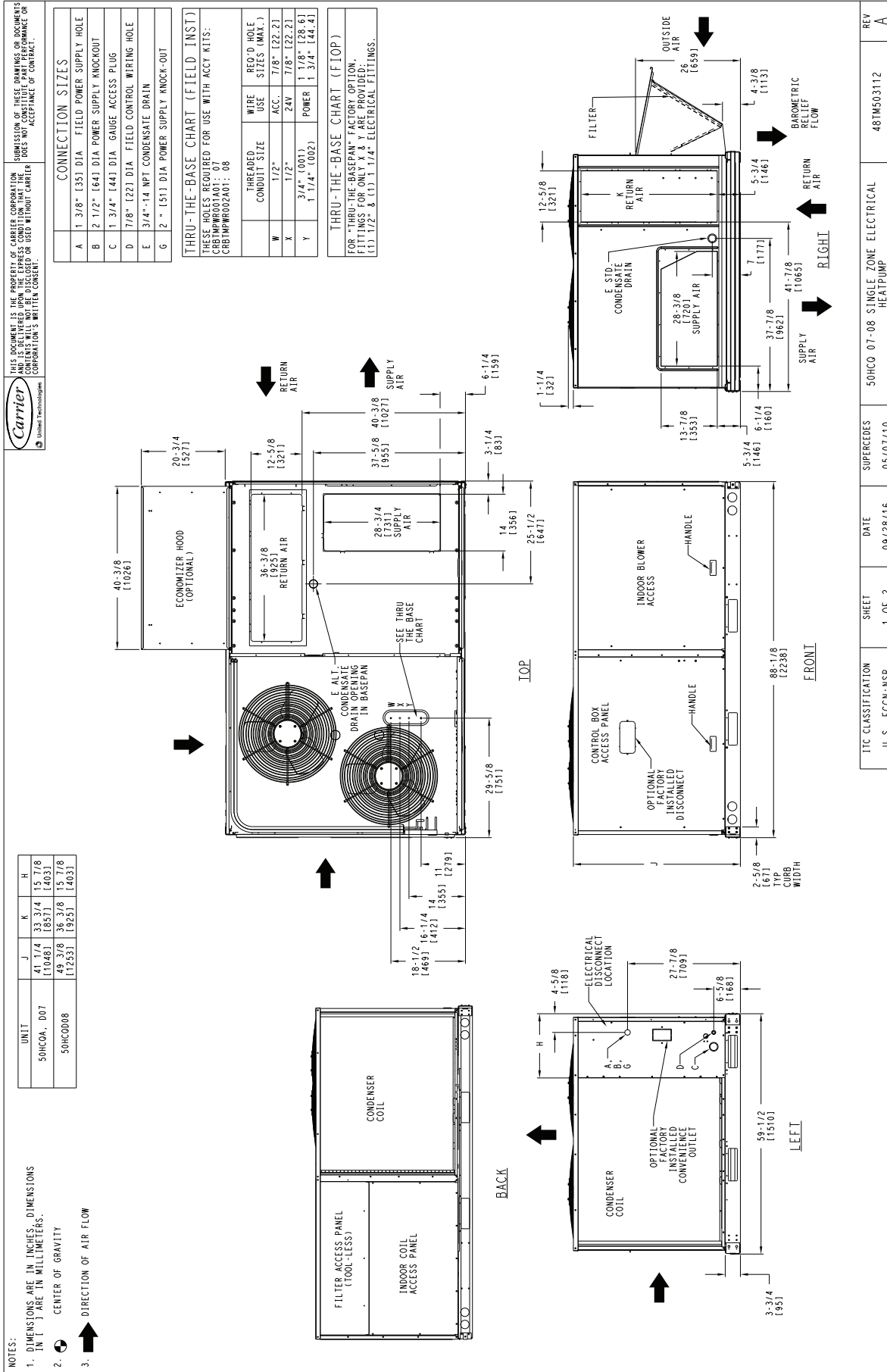

Fig. 2 — Unit Dimensional Drawing — 07-08 Size Units

THIS DOCUMENT IS THE PROPERTY OF CARRIER CORPORATION AND IS DELIVERED UPON THE EXPRESS CONDITION THAT THE CONTENTS WILL NOT BE DISCLOSED OR USED WITHOUT CARRIER CORPORATION'S WRITTEN CONSENT.



SUBMISSION OF THESE DRAWINGS OR DOCUMENTS DOES NOT CONSTITUTE AN ACCEPTANCE OF CONTRACT.

STANDARD UNIT WEIGHT IS WITHOUT ELECTRIC HEAT AND WITHOUT PACKAGING. FOR OTHER OPTIONS AND ACCESSORIES, REFER TO THE PRODUCT DATA CATALOG.

UNIT	STD. UNIT WEIGHT *		CORNER WEIGHT (A)		CORNER WEIGHT (B)		CORNER WEIGHT (C)		CORNER WEIGHT (D)		C.G.					
	LBS.	KG.	LBS.	KG.	LBS.	KG.	LBS.	KG.	LBS.	KG.	X	Y	Z			
50HCOA.D07	710	322	162	73.5	129	58.5	186	84.4	234	106	38	51/8 [881]	34	17/8 [867]	21	11/4 [540]
50HCO008	875	397	190	86.2	160	72.6	253	114.8	284	128.8	40	[1016]	34	5/8 [879]	24	3/8 [619]

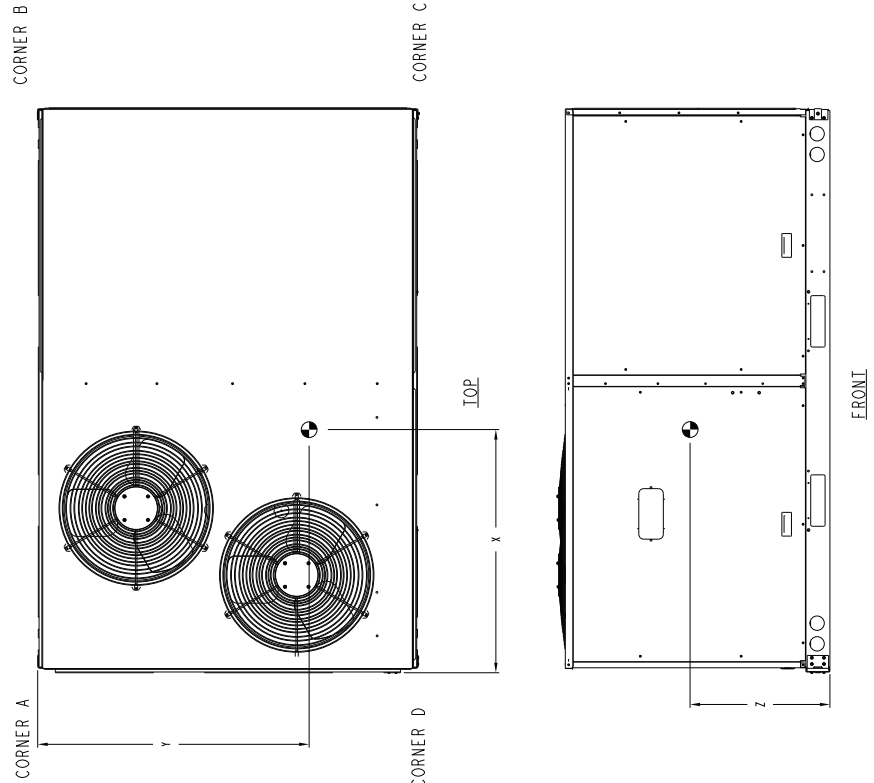

Fig. 2 — Unit Dimensional Drawing — 07-08 Size Units (cont)

TIC CLASSIFICATION U.S. - ECCN:NSR	SHEET 2 OF 2	DATE 09/28/16	SUPERCEDES 05/07/10	50HCO 07-08 SINGLE ZONE ELECTRICAL HEATPUMP	REV A
---------------------------------------	-----------------	------------------	------------------------	---	----------

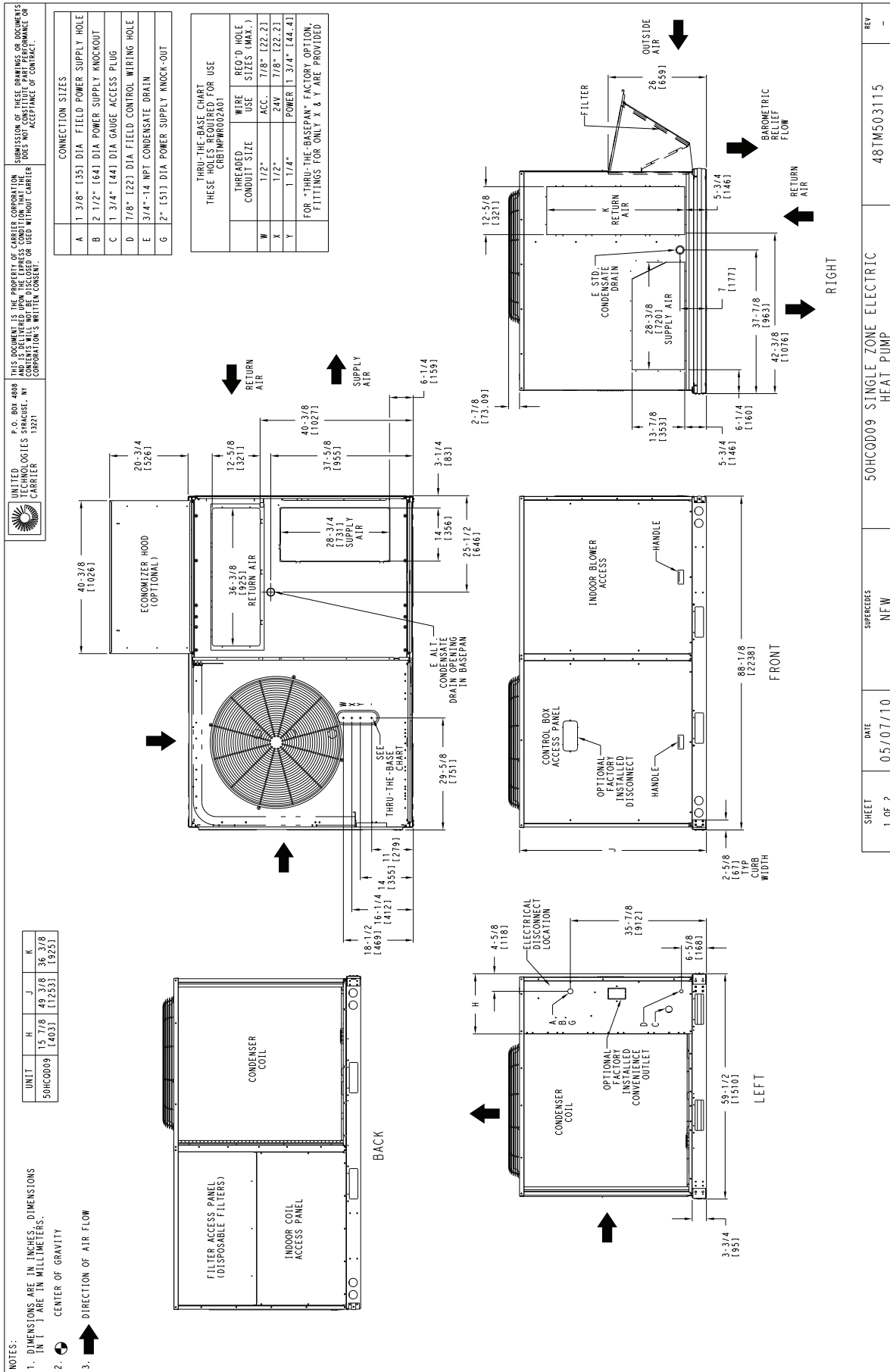

Fig. 3 — Unit Dimensional Drawing — 09 Size Units

UNITED STATES OF AMERICA
 UNITED TECHNOLOGIES SUPPLY CO., INC.
 CARRIER

THIS DOCUMENT IS THE PROPERTY OF CARRIER CORPORATION
 AND IS DELIVERED UPON THE EXPRESS CONDITION THAT THE
 CONTENTS WILL NOT BE DISCLOSED OR USED WITHOUT CARRIER
 CORPORATION'S WRITTEN CONSENT.

SUBMISSION OF THESE DRAWINGS OR DOCUMENTS
 DOES NOT CONSTITUTE AN ACCEPTANCE OF CONTRACT.

UNIT	STD. UNIT WEIGHT		CORNER WEIGHT (A)		CORNER WEIGHT (B)		CORNER WEIGHT (C)		CORNER WEIGHT (D)		C.G.					
	LBS.	KG.	LBS.	KG.	LBS.	KG.	LBS.	KG.	LBS.	KG.	X	Y	Z			
50HC009	1020	463	255	115.7	199	90.3	248	112.5	318	144.2	38 1/4	1972	32	1813	24	1610

* STANDARD UNIT WEIGHT IS WITHOUT ELECTRIC HEAT AND WITHOUT PACKAGING.
 FOR OPTIONS AND ACCESSORIES REFER TO THE PRODUCT DATA CATALOG.

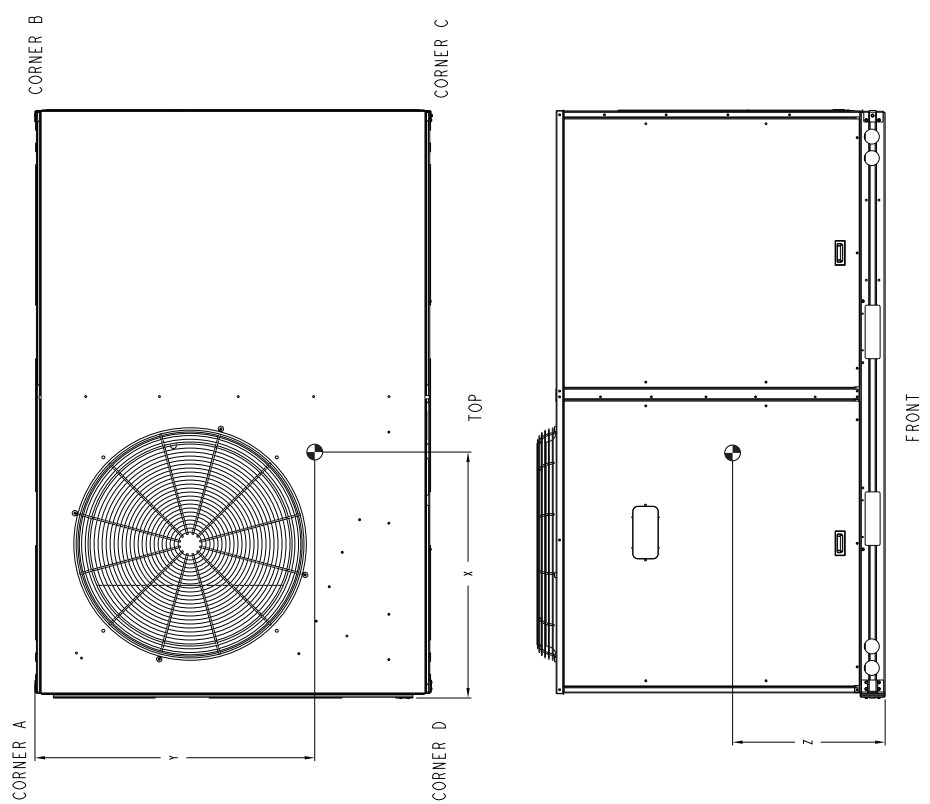

SHEET 2 OF 2	DATE 05/07/10	SUPERSEDES NEW	50HC009 SINGLE ZONE ELECTRIC HEAT PUMP	48TM503115	REV -
-----------------	------------------	-------------------	---	------------	----------

Fig. 3 — Unit Dimensional Drawing — 09 Size Units (cont)

INSTALLATION

Jobsite Survey

Complete the following checks before installation.

1. Consult local building codes and the NEC (National Electrical Code) ANSI/NFPA 70 for special installation requirements.
2. Determine unit location (from project plans) or select unit location.
3. Check for possible overhead obstructions which may interfere with unit lifting or rigging.

Step 1 — Plan for Unit Location

Select a location for the unit and its support system (curb or other) that provides for the minimum clearances required for safety (including clearance to combustible surfaces), unit performance and service access below, around and above unit as specified in unit drawings. See Fig. 4.

NOTE: Consider also the effect of adjacent units.

Unit may be installed directly on wood flooring or on Class A, B, or C roof-covering material when roof curb is used.

Do not install unit in an indoor location. Do not locate air inlets near exhaust vents or other sources of contaminated air.

Although unit is weatherproof, avoid locations that permit water from higher level runoff and overhangs to fall onto unit.

Select a unit mounting system that provides adequate height to allow installation of condensate trap per requirements. Refer to Step 10 — Install External Condensate Trap and Line on page 14 for required trap dimensions.

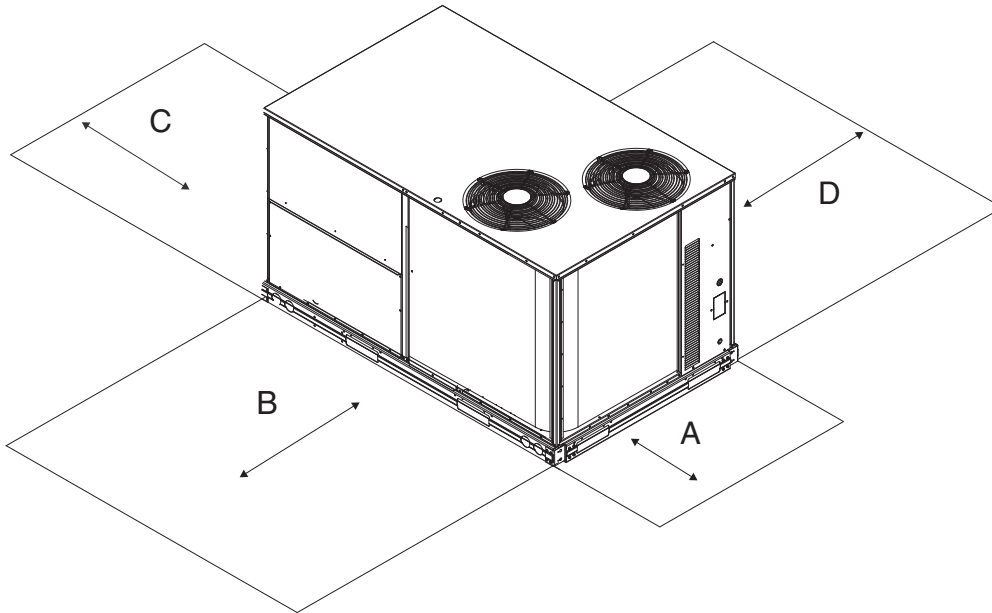

LOCATION	DIMENSION	CONDITION
A	48-in. (1219 mm) 18-in. (457 mm) 18-in. (457 mm) 12-in. (305 mm)	Unit disconnect is mounted on panel No disconnect, convenience outlet option Recommended service clearance Minimum clearance
B	42-in. (1067 mm) 36-in. (914 mm) Special	Surface behind servicer is grounded (e.g., metal, masonry wall) Surface behind servicer is electrically non-conductive (e.g., wood, fiberglass) Check sources of flue products within 10-ft (3 m) of unit fresh air intake hood
C	36-in. (914 mm) 18-in. (457 mm)	Side condensate drain is used Minimum clearance
D	42-in. (1067 mm) 36-in. (914 mm) Special	Surface behind servicer is grounded (e.g., metal, masonry wall, another unit) Surface behind servicer is electrically non-conductive (e.g., wood, fiberglass) Check for adjacent units or building fresh air intakes within 10-ft (3 m) of this unit's flue outlet

NOTE: Unit not designed to have overhead obstruction. Contact Application Engineering for guidance on any application planning overhead obstruction or for vertical clearances.

Fig. 4 — Service Clearance Dimensional Drawing

ROOF MOUNT

Check building codes for weight distribution requirements. Unit operating weight is shown in Table 2.

Table 2 — Operating Weights

50HCQ	UNIT LB (KG)		
	A,D07	D08	D09
Base Unit	710 (322)	875 (397)	1020 (463)
Economizer			
Vertical	80 (36)	80 (36)	80 (36)
Horizontal	105 (48)	105 (48)	105 (48)
Powered Outlet	32 (15)	32 (15)	32 (15)
Curb			
14 in. (356 mm)	110 (50)	110 (50)	110 (50)
24 in. (610 mm)	145 (66)	145 (66)	145 (66)

Step 2 — Plan for Sequence of Unit Installation

The support method used for this unit will dictate different sequences for the steps of unit installation. For example, on curb-mounted units, some accessories must be installed on the unit before the unit is placed on the curb. Review the following for recommended sequences for installation steps:

CURB-MOUNTED INSTALLATION

1. Install curb.
2. Install field-fabricated ductwork inside curb.
3. Install accessory thru-base service connection package (affects curb and unit) (refer to accessory installation instructions for details).
4. Prepare bottom condensate drain connection to suit planned condensate line routing (refer to Step 10 — Install External Condensate Trap and Line on page 14 for details).
5. Rig and place unit.
6. Install outdoor air hood.
7. Install condensate line trap and piping.
8. Make electrical connections.
9. Install other accessories.

PAD-MOUNTED INSTALLATION

1. Prepare pad and unit supports.
2. Check and tighten the bottom condensate drain connection plug.
3. Rig and place unit.
4. Convert unit to side duct connection arrangement.
5. Install field-fabricated ductwork at unit duct openings.
6. Install outdoor air hood.
7. Install condensate line trap and piping.
8. Make electrical connections.
9. Install other accessories.

FRAME-MOUNTED INSTALLATION

Frame-mounted applications generally follow the sequence for a curb installation. Adapt the sequence as required to suit specific installation plan.

Step 3 — Inspect Unit

Inspect unit for transportation damage. File any claim with transportation agency.

Confirm before installation of unit that voltage, amperage and circuit protection requirements listed on unit data plate agree with power supply provided.

On units with hinged panel option, check to be sure all latches are snug and in closed position.

Locate the carton containing the outside air hood parts. Do not remove carton until unit has been rigged and located in final position.

Step 4 — Provide Unit Support

ROOF CURB MOUNT

Accessory roof curb details and dimensions are shown in Fig. 5. Assemble and install accessory roof curb in accordance with instructions shipped with the curb.

Curb should be level. This is necessary for unit drain to function properly. Unit leveling tolerances are shown in Fig. 6. Refer to Accessory Roof Curb Installation Instructions for additional information as required.

Install insulation, cant strips, roofing felt, and counter flashing as shown. *Ductwork must be attached to curb and not to the unit. The accessory thru-the-base power connection package must be installed before the unit is set on the roof curb.*

If electric and control wiring is to be routed through the basepan, attach the accessory thru-the-base service connections to the basepan in accordance with the accessory installation instructions.

NOTE: The gasketing of the unit to the roof curb is critical for a watertight seal. Install gasket supplied with the roof curb as shown in Fig. 5. Improperly applied gasket can also result in air leaks and poor unit performance.

SLAB MOUNT (HORIZONTAL UNITS ONLY)

Provide a level concrete slab that extends a minimum of 6 in. (150 mm) beyond unit cabinet. Install a gravel apron in front of condenser coil air inlet to prevent grass and foliage from obstructing airflow.

NOTE: Horizontal units may be installed on a roof curb if required.

ALTERNATE UNIT SUPPORT (IN LIEU OF CURB OR SLAB MOUNT)

A non-combustible sleeper rail can be used in the unit curb support area. If sleeper rails cannot be used, support the long sides of the unit with a minimum of 3 equally spaced 4-in. x 4-in. (102 mm x 102 mm) pads on each side.

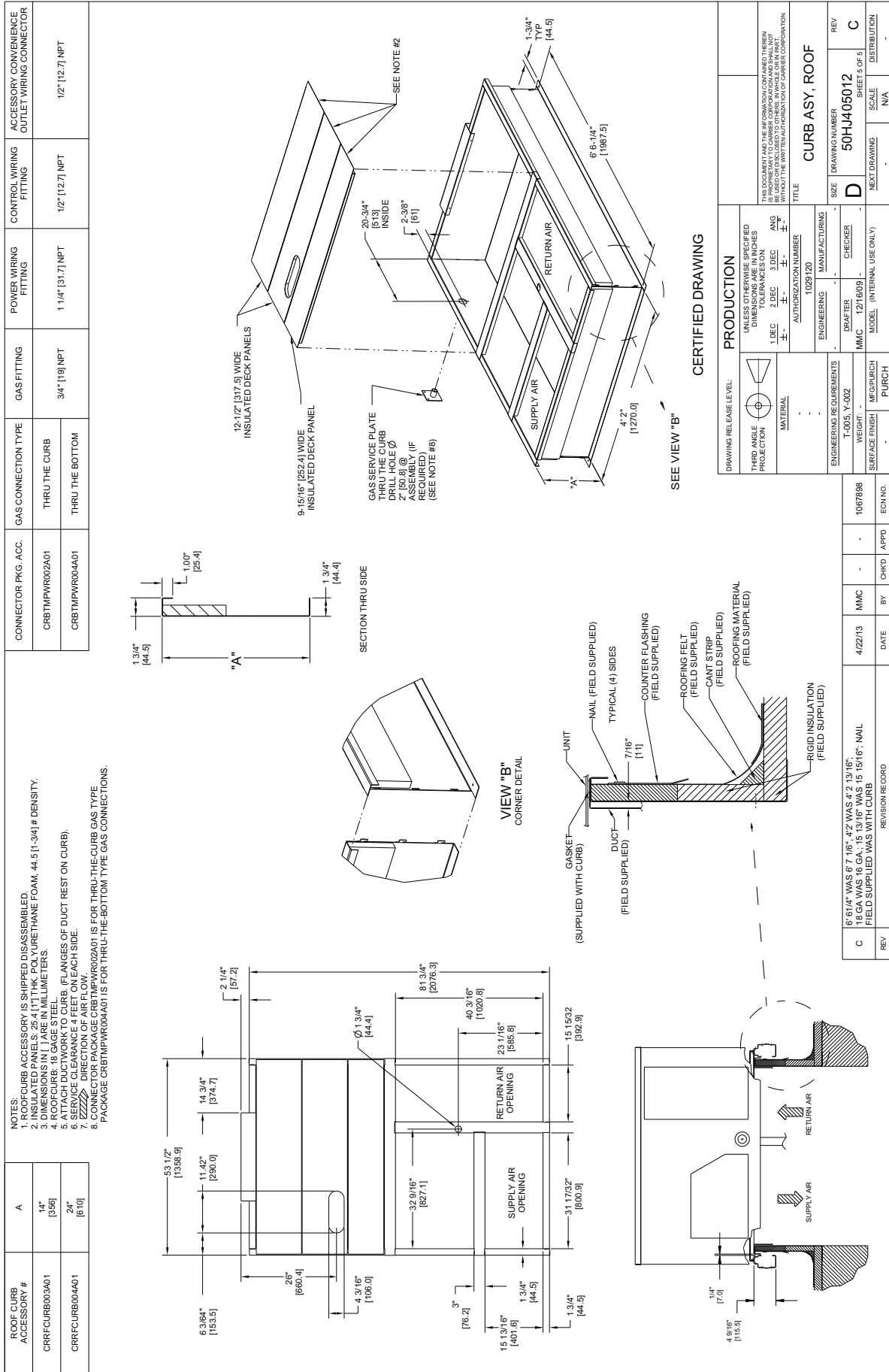

Fig. 5 — Roof Curb Details

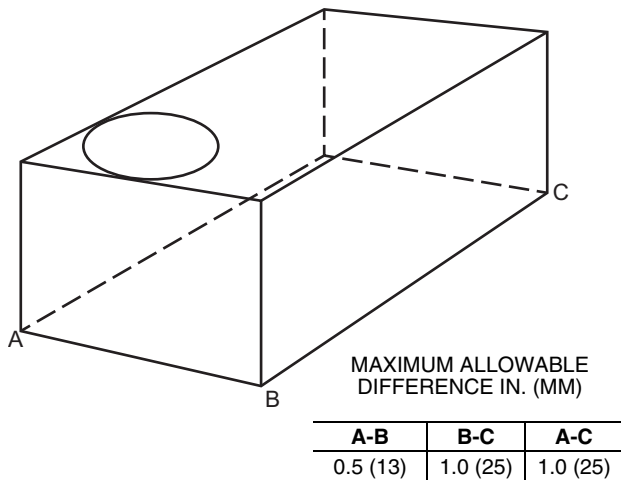

Fig. 6 — Unit Leveling Tolerances

Step 5 — Field Fabricate Ductwork

Cabinet return-air static pressure (a negative condition) shall not exceed 0.35 in. wg (87 Pa) with economizer or 0.45 in. wg (112 Pa) without economizer.

For vertical ducted applications, secure all ducts to roof curb and building structure. *Do not connect ductwork to unit.*

Fabricate supply ductwork so that the cross sectional dimensions are equal to or greater than the unit supply duct opening dimensions for the first 18 in. (458 mm) of duct length from the unit basepan.

Insulate and weatherproof all external ductwork, joints, and roof openings with counter flashing and mastic in accordance with applicable codes.

Ducts passing through unconditioned spaces must be insulated and covered with a vapor barrier.

If a plenum return is used on a vertical unit, the return should be ducted through the roof deck to comply with applicable fire codes.

⚠ CAUTION

Failure to follow this caution may result in damage to roofing materials.

Membrane roofs can be cut by sharp sheet metal edges. Be careful when placing any sheet metal parts on such roof.

UNITS WITH ACCESSORY ELECTRIC HEATERS

All installations require a minimum clearance to combustible surfaces of 1 in. (25 mm) from duct for first 12 in. (305 mm) away from unit.

Outlet grilles must not lie directly below unit discharge.

NOTE: A 90-degree elbow must be provided in the ductwork to comply with UL (Underwriters Laboratories) code for use with electric heat.

⚠ WARNING

Failure to follow this warning could cause personal injury. For vertical supply and return units, tools or parts could drop into ductwork and cause an injury. Install a 90-degree turn in the return ductwork between the unit and the conditioned space. If a 90-degree elbow cannot be installed, then a grille of sufficient strength and density should be installed to prevent objects from falling into the conditioned space. Due to electric heater, supply duct will require 90-degree elbow.

Step 6 — Rig and Place Unit

Keep unit upright and do not drop. Spreader bars are required. Rollers may be used to move unit across a roof. Rigging materials under unit (cardboard or wood) must be removed PRIOR to placing the unit on the roof curb. Level by using unit frame as a reference. See Table 2 on page 9 and Fig. 7 for additional information.

Lifting holes are provided in base rails as shown in Fig. 7. Refer to rigging instructions on unit.

Before setting the unit onto the curb, recheck gasketing on curb.

⚠ CAUTION

Failure to follow this caution may result in equipment damage.

All panels must be in place when rigging. Unit is not designed for handling by fork truck when panels or packaging are removed.

If using top crate as spreader bar, once unit is set, carefully lower wooden crate off building roof top to ground. Ensure that no people or obstructions are below prior to lowering the crate.

Position unit on roof curb so that the following clearances are maintained: 1/4 in. (6.4 mm) clearance between the roof curb and the base rail inside the front and rear, 0.0 in. clearance between the roof curb and the base rail inside on the duct end of the unit. This will result in the distance between the roof curb and the base rail inside on the condenser end of the unit being approximately 1/4 in. (6.4 mm).

Although unit is weatherproof, guard against water from higher level runoff and overhangs.

⚠ CAUTION

Failure to follow this caution may result in equipment damage.

All panels must be in place when rigging. Unit is not designed for handling by fork truck when panels or packaging are removed.

After unit is in position, remove the compressor access panel. Holding the blocking between compressors with one hand, cut the strapping. Carefully remove the blocking without damaging tubing, wiring, or controls. Remove the strapping and replace the access panel.

After unit is in position, remove rigging skids and shipping materials.

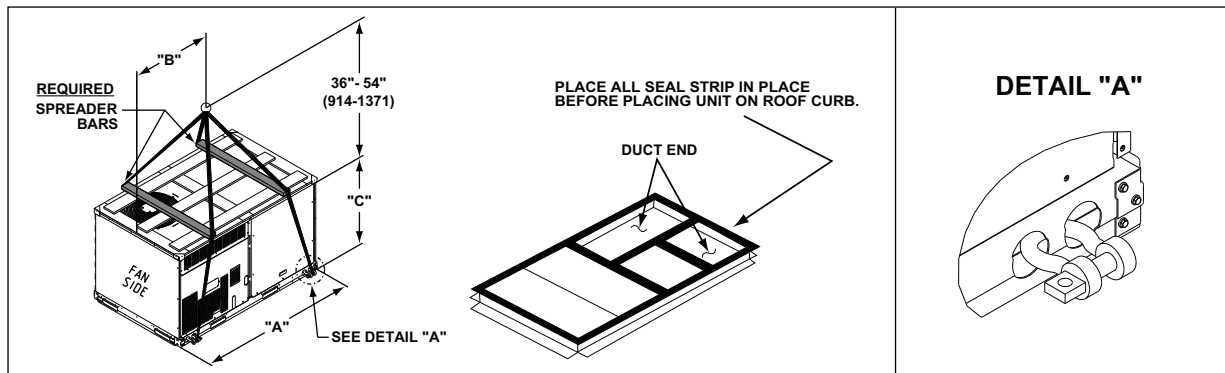

UNIT	MAX WEIGHT		DIMENSIONS					
			A		B		C	
	lb	kg	in.	mm	in.	mm	in.	mm
50HCQA,D07	1100	500	88.0	2235	40.8	1035	41.5	1055
50HCQD08	1315	598	88.0	2235	41.6	1057	49.5	1257
50HCQD09	1505	684	88.0	2235	40.0	1015	49.5	1257

- NOTES:
1. SPREADER BARS REQUIRED — Top damage will occur if spreader bars are not used.
 2. Dimensions in () are in millimeters.
 3. Hook rigging shackles through holes in base rail, as shown in detail "A." Holes in base rails are centered around the unit center of gravity. Use wooden top to prevent rigging straps from damaging unit.

Fig. 7 — Rigging Details

Step 7 — Convert to Horizontal and Connect Ductwork (when required)

Unit is shipped in the vertical duct configuration. Unit without factory-installed economizer or return-air smoke detector option may be field-converted to horizontal ducted configuration. To convert to horizontal configuration, remove screws from side duct opening covers (see Fig. 8) and remove covers. Use the screws to install the covers on vertical duct openings with the insulation-side down. The panels must be inserted into the notches on the basepan to properly seal. The notches are covered by the tape used to secure the insulation to the basepan and are not easily seen. See Fig. 9 for position of the notches in the basepan. Seals around duct openings must be tight. Secure with screws as shown in Fig. 10. Cover seams with foil duct tape.

Field-supplied flanges should be attached to horizontal duct openings and all ductwork should be secured to the flanges. Insulate and weatherproof all external ductwork, joints, and roof or building openings with counter flashing and mastic in accordance with applicable codes.

Do not cover or obscure visibility to the unit's informative data plate when insulating horizontal ductwork.

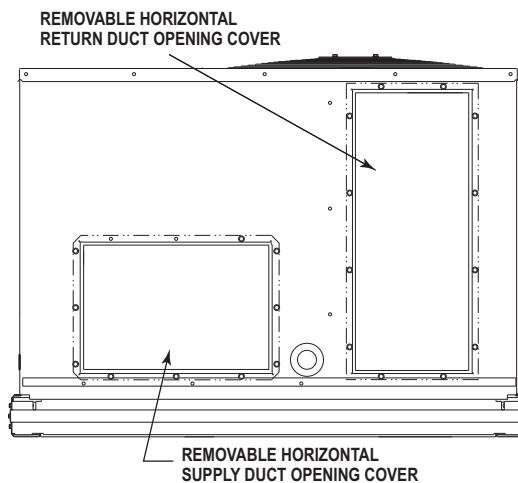

Fig. 8 — Horizontal Conversion Panels

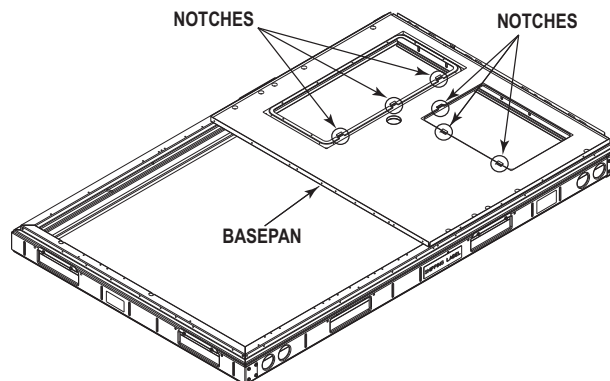

Fig. 9 — Location of Notches

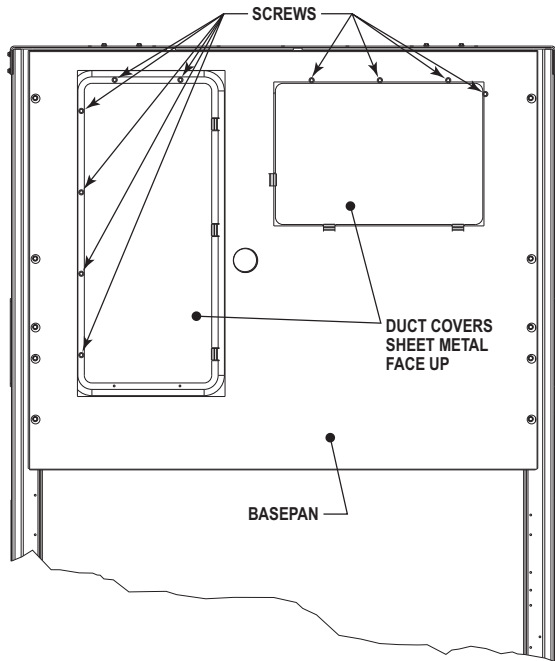

Fig. 10 — Horizontal Duct Panels In Place

Step 8 — Install Outside Air Hood

ECONOMIZER HOOD REMOVAL AND SETUP (FACTORY OPTION)

The hood is shipped in knock-down form and located in the return air compartment. It is attached to the economizer using two plastic tie-wraps.

1. To gain access to the hood, remove the filter access panel. (See Fig. 11.)
2. Locate and cut the (2) plastic tie-wraps, being careful not to damage any wiring. (See Fig. 12.)
3. Carefully lift the hood assembly through the filter access opening and assemble per the steps outlined in Economizer Hood and Two-Position Hood Assembly on page 14.

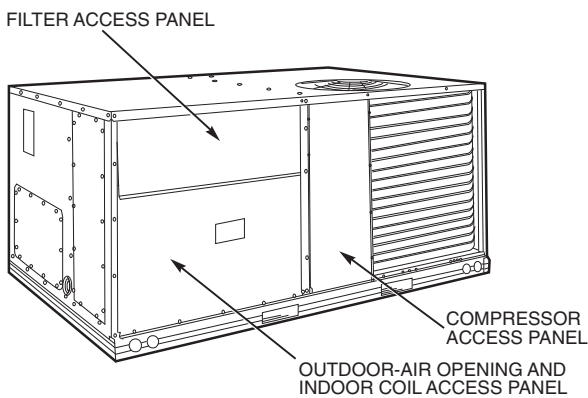

Fig. 11 — Typical Access Panel Locations

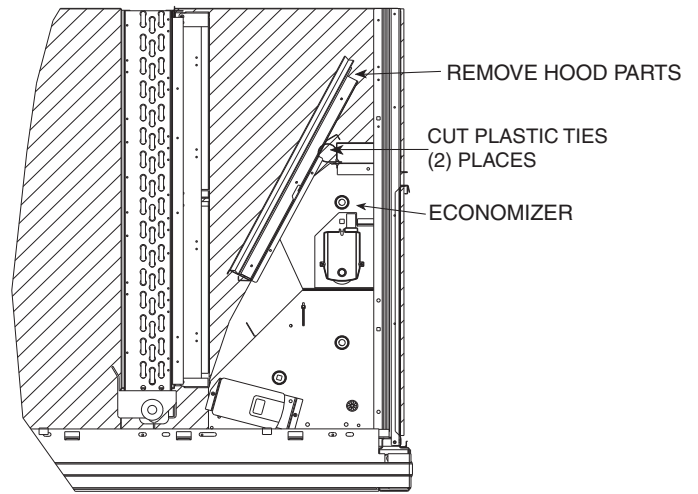

Fig. 12 — Economizer Wiring

TWO-POSITION DAMPER HOOD REMOVAL AND SETUP (FACTORY OPTION)

The hood is shipped in knock-down form and assembled to a metal support tray using plastic stretch wrap. Located in the return air compartment, the assembly's metal tray is attached to the basepan and also attached to the damper using two plastic tie-wraps.

1. To gain access to the hood, remove the filter access panel. (See Fig. 11.)
2. Locate the (2) screws holding the metal tray to the basepan and remove. Locate and cut the (2) plastic tie-wraps securing the assembly to the damper. (See Fig. 13.) Be careful not to damage any wiring or cut tie-wraps securing any wiring.
3. Carefully lift the hood assembly (with metal tray) through the filter access opening and assemble per the steps outlined in Economizer Hood and Two-Position Hood Assembly on page 14.

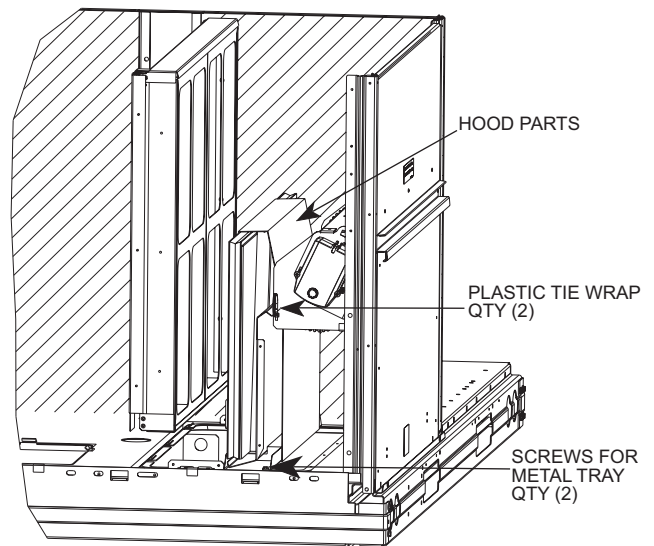

Fig. 13 — Damper Assembly

ECONOMIZER AND TWO-POSITION HOOD ASSEMBLY

NOTE: If the power exhaust accessory is to be installed on the unit, the hood shipped with the unit will not be used and must be discarded. Save the aluminum filter for use in the power exhaust hood assembly.

1. The indoor coil access panel will be used as the top of the hood. Remove the screws along the sides and bottom of the indoor coil access panel. See Fig. 14.

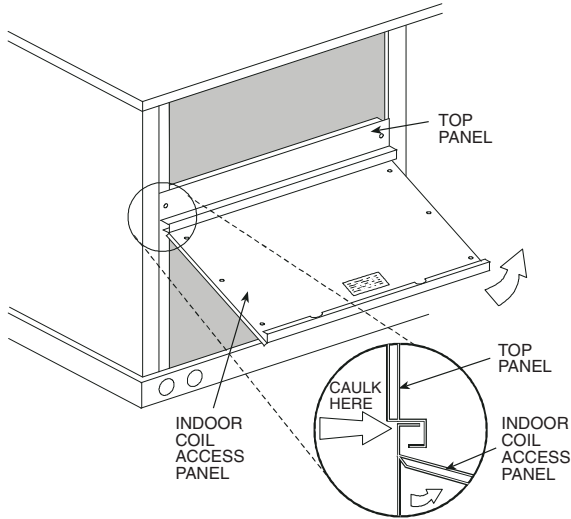

Fig. 14 — Indoor Coil Access Panel Relocation

2. Swing out indoor coil access panel and insert the hood sides under the panel (hood top). Use the screws provided to attach the hood sides to the hood top. Use screws provided to attach the hood sides to the unit. See Fig. 15.

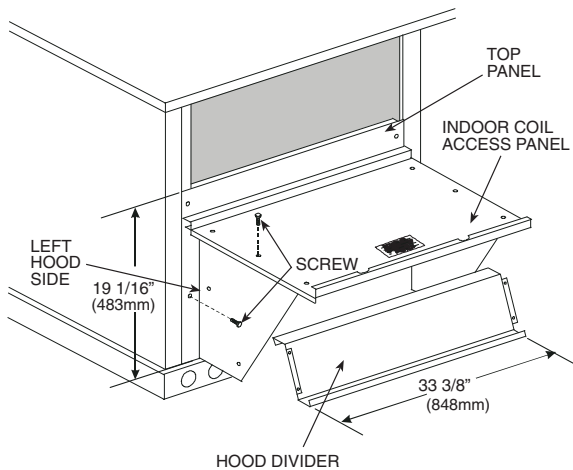

Fig. 15 — Economizer Hood Construction

3. Remove the shipping tape holding the economizer barometric relief damper in place (economizer only).
4. Insert the hood divider between the hood sides. See Fig. 15 and 16. Secure hood divider with 2 screws on each hood side. The hood divider is also used as the bottom filter rack for the aluminum filter.
5. Open the filter clips which are located underneath the hood top. Insert the aluminum filter into the bottom filter rack (hood divider). Push the filter into position past the open filter clips. Close the filter clips to lock the filter into place. See Fig. 16.

6. Caulk the ends of the joint between the unit top panel and the hood top.
7. Replace the filter access panel.

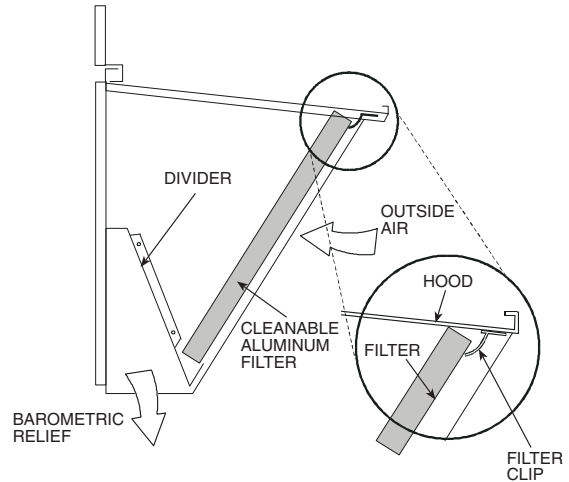

Fig. 16 — Economizer Filter Installation

Step 9 — Units with Hinged Panels Only

Relocate latch shipped inside the compressor compartment behind the hinged compressor door to location shown in Fig. 17 after unit installation.

If the unit does not have hinged panels, skip this step and continue at Step 10 below.

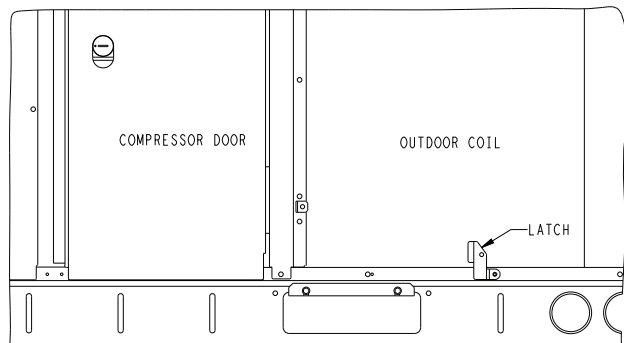

Fig. 17 — Compressor Door Latch Location

Step 10 — Install External Condensate Trap and Line

The unit has one $\frac{3}{4}$ -in. condensate drain connection on the end of the condensate pan and an alternate connection on the bottom. See Fig. 18. Unit airflow configuration does not determine which drain connection to use. Either drain connection can be used with vertical or horizontal applications.

When using the standard side drain connection, ensure that the red plug in the alternate bottom connection is tight. Do this before setting the unit in place. The red drain pan plug can be tightened with a $\frac{1}{2}$ -in. square socket drive extension.

To use the alternate bottom drain connection, remove the red drain plug from the bottom connection (use a $\frac{1}{2}$ -in. square socket drive extension) and install it in the side drain connection.

The piping for the condensate drain and external trap can be completed after the unit is in place. See Fig. 19.

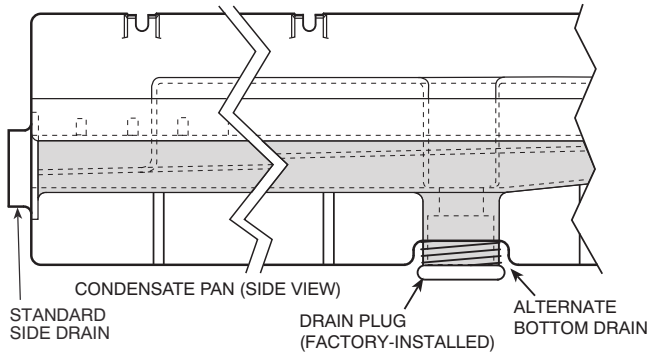
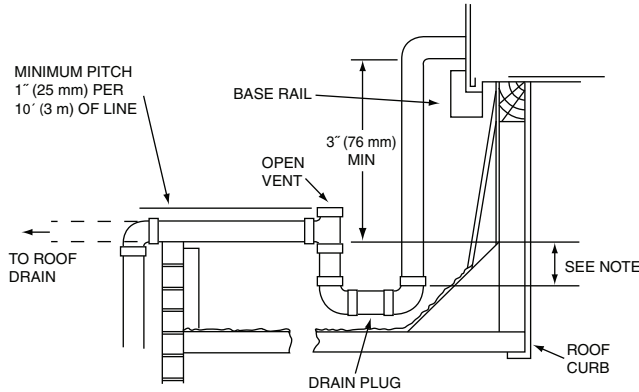

Fig. 18 — Condensate Drain Pan (Side View)



NOTE: Trap should be deep enough to offset maximum unit static difference. A 4-in. (102 mm) trap is recommended.

Fig. 19 — Condensate Drain Pan Piping Details

All units must have an external trap for condensate drainage. Install a trap at least 4 in. (102 mm) deep and protect against freeze-up. If drain line is installed downstream from the external trap, pitch the line away from the unit at 1 in. per 10 ft (25 mm per 3 m) of run. Do not use a pipe size smaller than the unit connection (3/4 in.).

Step 11 — Make Electrical Connections

⚠ WARNING

ELECTRICAL SHOCK HAZARD

Failure to follow this warning could result in personal injury or death.

Unit cabinet must have an uninterrupted, unbroken electrical ground to minimize the possibility of personal injury if an electrical fault should occur. This ground may consist of electrical wire connected to unit ground lug in control compartment, or conduit approved for electrical ground when installed in accordance with NEC (National Electrical Code); ANSI/NFPA 70, latest edition (in Canada, Canadian Electrical Code CSA [Canadian Standards Association] C22.1), and local electrical codes.

NOTE: Field-supplied wiring shall conform with the limitations of minimum 63°F (33°C) rise.

FIELD POWER SUPPLY

If equipped with optional Powered Convenience Outlet, the power source leads to the convenience outlet's transformer primary are not factory connected. Installer must connect these leads according to required operation of the convenience outlet. If an always-energized convenience outlet operation is desired, connect the source leads to the line side of the unit-mounted disconnect. (Check with local codes to ensure this

method is acceptable in your area.) If a de-energize via unit disconnect switch operation of the convenience outlet is desired, connect the source leads to the load side of the unit disconnect. On a unit without a unit-mounted disconnect, connect the source leads to compressor contactor C and indoor fan contactor IFC pressure lugs with unit field power leads. See Convenience Outlets on page 16 for power transformer connections.

The field power wires are connected to the unit at line-side pressure lugs on compressor contactor C and indoor fan contactor IFC (see wiring diagram label for control box component arrangement) or at factory-installed option non-fused disconnect switch. Maximum wire size is #2ga AWG (copper only). See Fig. 21 and unit label diagram for field power wiring connections.

NOTE: Unit may be equipped with short test leads (pigtailed) on the field line connection points on contactor C or optional disconnect switch. These leads are for factory-run test purposes only; remove and discard before connecting field power wires to unit connection points. Make field power connections directly to line connection pressure lugs only.

⚠ WARNING

FIRE HAZARD

Failure to follow this caution could result in fire, intermittent operation, or unsatisfactory performance.

Do not connect aluminum wire between disconnect switch and air conditioning unit. Use only copper wire. See Fig. 20.

Connect field power supply conductors to LINE side terminals when the switch enclosure cover is removed to attach the handle.

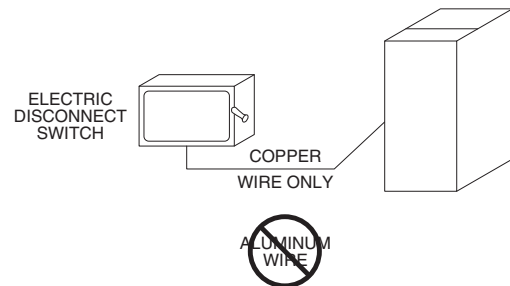

Fig. 20 — Disconnect Switch and Unit

UNITS WITHOUT FACTORY-INSTALLED DISCONNECT

When installing units, provide a disconnect switch per NEC (National Electrical Code) of adequate size. Disconnect sizing data is provided on the unit informative plate. Locate on unit cabinet or within sight of the unit per national or local codes. Do not cover unit informative plate if mounting the disconnect on the unit cabinet.

UNITS WITH FACTORY-INSTALLED DISCONNECT

The factory-installed optional disconnect switch is located in a weatherproof enclosure located under the main control box. The manual switch handle is accessible through an opening in the access panel. Discard the factory test leads (see Fig. 21).

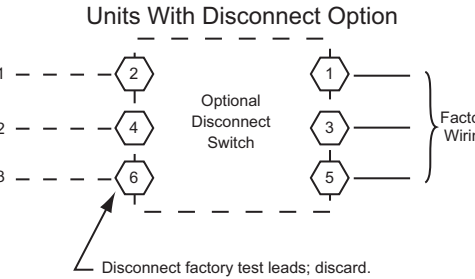
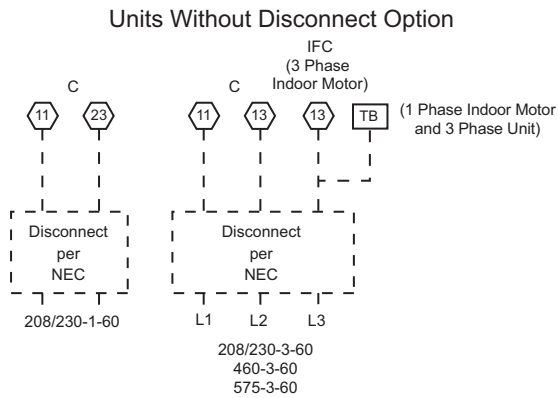

Fig. 21 — Power Wiring Connections

ALL UNITS

All field wiring must comply with NEC and all local codes. Size wire based on MCA (Minimum Circuit Amps) on the unit informative plate. See Fig. 21 and the unit label diagram for power wiring connections to the unit power terminal blocks and equipment ground. Maximum wire size is #2ga AWG (copper only) per pole.

Provide a ground fault and short circuit over-current protection device (fuse or breaker) per NEC Article 440 (or local codes). Refer to unit informative data plate for MOCP (Maximum Over-Current Protection) device size.

All field wiring must comply with the NEC and local requirements.

All units except 208/230v units are factory wired for the voltage shown on the nameplate. *If the 208/230v unit is to be connected to a 208v power supply, the control transformer must be rewired by removing the black wire with the 1/4-in. female spade connector from the 230v connection and moving it to the 200v 1/4-in. male terminal on the primary side of the transformer. Refer to unit label diagram for additional information. Field power wires will be connected at line-side pressure lugs on the power terminal block or at factory-installed option non-fused disconnect.*

NOTE: Check all factory and field electrical connections for tightness.

Voltage to compressor terminals during operation must be within voltage range indicated on unit nameplate. On 3-phase units, voltages between phases must be balanced within 2% and the current within 10%. Use the formula shown in the example below to determine the percent of voltage imbalance. Operation on improper line voltage or excessive phase imbalance constitutes abuse and may cause damage to electrical components. Such operation would invalidate any applicable Carrier warranty.

NOTE: Check all factory and field electrical connections for tightness.

CONVENIENCE OUTLETS

⚠ WARNING

ELECTRICAL OPERATION HAZARD

Failure to follow this warning could result in personal injury or death.

Units with convenience outlet circuits may use multiple disconnects. Check convenience outlet for power status before opening unit for service. Locate its disconnect switch, if appropriate, and open it. Lock-out and tag-out this switch, if necessary.

Two types of convenience outlets are offered on 50HCQ models: non-powered and unit-powered. Both types provide a 125-volt GFCI (ground-fault circuit interrupter) duplex receptacle rated at 15A behind a hinged waterproof access cover, located on the end panel of the unit. See Fig. 22.

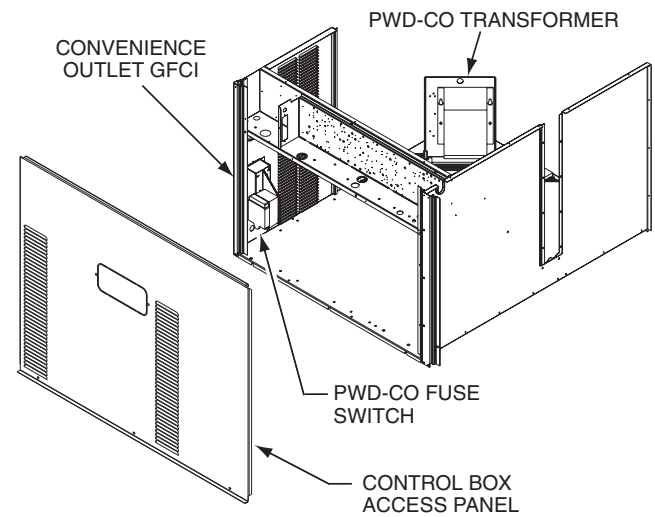

Fig. 22 — Convenience Outlet Location

Installing Weatherproof Cover

A weatherproof while-in-use cover for the factory-installed convenience outlets is now required by UL standards. This cover cannot be factory-mounted due its depth; it must be installed at unit installation. For shipment, the convenience outlet is covered with a blank cover plate.

The weatherproof cover kit is shipped in the unit's control box. The kit includes the hinged cover, a backing plate, and gasket.

⚠ WARNING

Failure to follow this warning could result in personal injury or death.

Disconnect all power to unit and convenience outlet. Lock-out and tag-out all power.

1. Remove the blank cover plate at the convenience outlet; discard the blank cover.
2. Loosen the two screws at the GFCI duplex outlet, until approximately 1/2 in. (13 mm) under screw heads is exposed. Press the gasket over the screw heads.
3. Slip the backing plate over the screw heads at the keyhole slots and align with the gasket; tighten the two screws until snug (do not over-tighten).
4. Mount the weatherproof cover to the backing plate as shown in Fig. 23.

5. Remove two slot fillers in the bottom of the cover to permit service tool cords to exit the cover.
6. Check for full closing and latching.

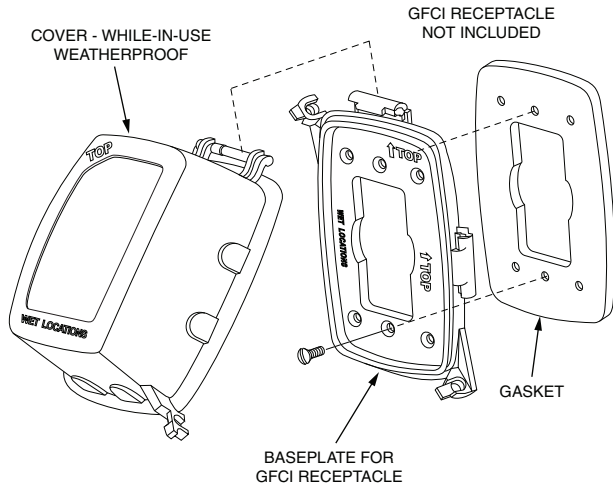

Fig. 23 — Weatherproof Cover Installation

Non-Powered Convenience Outlet

This type requires the field installation of a general-purpose 125v 15A circuit powered from a source elsewhere in the building. Observe national and local codes when selecting wire size, fuse or breaker requirements, and disconnect switch size and location. Route 125v power supply conductors into the bottom of the utility box containing the duplex receptacle.

Unit-Powered Convenience Outlet

A unit-mounted transformer is factory-installed to step down the main power supply voltage to the unit to 115v at the duplex receptacle. This option also includes a manual switch with fuse, located in a utility box and mounted on a bracket behind the convenience outlet; access is through the unit's control box access panel. See Fig. 22.

The primary leads to the convenience outlet transformer are not factory-connected. Selection of primary power source is a customer option. If local codes permit, the transformer primary leads can be connected at the line-side terminals on the unit-mounted non-fused disconnect switch; this will provide service power to the unit when the unit disconnect switch is open. Other connection methods will result in the convenience outlet circuit being de-energized when the unit disconnect switch is open. See Fig. 24.

Using Unit-Mounted Convenience Outlets

Units with unit-mounted convenience outlet circuits will often require that two disconnects be opened to de-energize all power to the unit. Treat all units as electrically energized until the convenience outlet power is also checked and de-energization is confirmed. Observe National Electrical Code Article 210, Branch Circuits, for use of convenience outlets.

Fuse On Power Type

The factory fuse is a Bussman "Fusetron"¹ T-15, non-renewable screw-in (Edison base) type plug fuse.

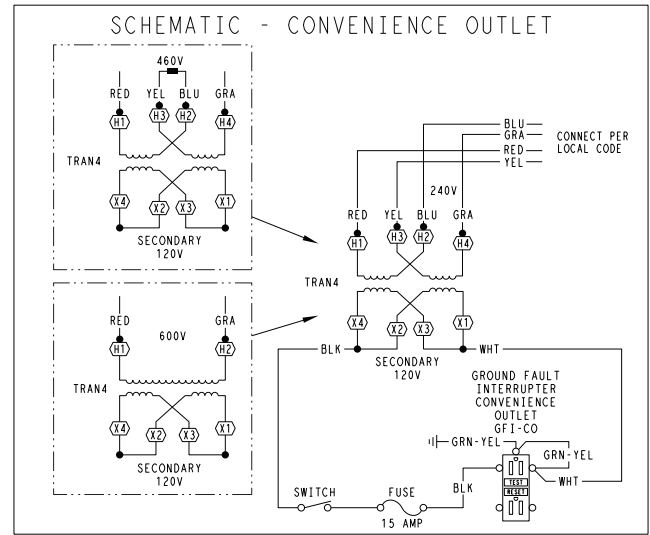

UNIT VOLTAGE	CONNECT AS	PRIMARY CONNECTIONS	TRANSFORMER TERMINALS
208, 230	240	L1: RED + YEL L2: BLU + GRA	H1 + H3 H2 + H4
460	480	L1: RED L2: Splice BLU + YEL L3: GRA	H1 H2 + H3 H4
575	600	L1: RED L2: GRA	H1 H2

Fig. 24 — Powered Convenience Outlet Wiring

Duty Cycle

The unit-powered convenience outlet has a duty cycle limitation. The transformer is intended to provide power on an intermittent basis for service tools, lamps, etc; it is not intended to provide 15-amps loading for continuous duty loads (such as electric heaters for overnight use). Observe a 50% limit on circuit loading above 8 amps. Convenience outlet usage rating:

- Continuous usage: 8 amps maximum
- Intermittent usage: Up to 15 amps maximum for up to 2 hours maximum

See Fig. 25.

Test the GFCI receptacle by pressing the TEST button on the face of the receptacle to trip and open the receptacle. Check for proper grounding wires and power line phasing if the GFCI receptacle does not trip as required. Press the RESET button to clear the tripped condition.

NOTICE

Convenience Outlet Utilization

Maximum Continuous use: 15 Amps for receptacle outlets, and 8 Amps for factory supplied transformers

50HJ542739 C

Fig. 25 — Convenience Outlet Utilization Notice Label

1. Bussman and Fusetron are trademarks of Cooper Technologies Company.

**FACTORY-OPTION THRU-BASE CONNECTIONS
(ELECTRICAL CONNECTIONS)**

This service connection kit consists of a 1/2-in. electrical bulkhead connector and a 3/4-in. electrical bulkhead connector, all factory-installed in the embossed (raised) section of the unit basepan in the condenser section. The 3/4-in. bulkhead connector enables the low-voltage control wires to pass through the basepan. The 1/2-in. electrical bulkhead connector allows the high-voltage power wires to pass through the basepan. See Fig. 26.

Check tightness of connector lock nuts before connecting electrical conduits.

Field-supplied and field-installed liquid tight conduit connectors and conduit may be attached to the connectors on the basepan. Pull correctly rated high voltage and low voltage through appropriate conduits. Connect the power conduit to the internal disconnect (if unit is so equipped) or to the external disconnect (through unit side panel). A hole must be field cut in the main control box bottom on the left side so the 24-v control connections can be made. Connect the control power conduit to the unit control box at this hole.

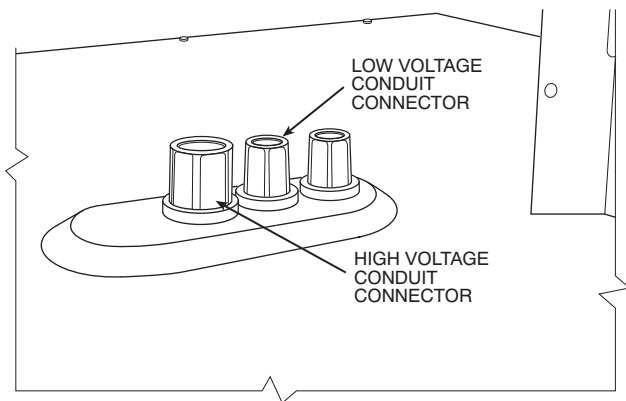

Fig. 26 — Thru-Base Connection Fittings

UNITS WITHOUT THRU-BASE CONNECTIONS (ELECTRICAL CONNECTIONS)

1. Install power wiring conduit through side panel openings. Install conduit between disconnect and control box.
2. Install power lines to terminal connections as shown in Fig. 21 on page 16.

Voltage to compressor terminals during operation must be within voltage range indicated on unit nameplate. On 3-phase units, voltages between phases must be balanced within 2% and the current within 10%. Use the formula shown in the example below to determine the percent of voltage imbalance. Operation on improper line voltage or excessive phase imbalance constitutes abuse and may cause damage to electrical components. Such operation would invalidate any applicable Carrier warranty.

Example: Supply voltage is 230-3-60

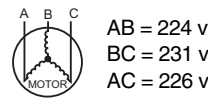

$$\text{Average Voltage} = \frac{(224 + 231 + 226)}{3} = \frac{681}{3} = 227$$

Determine maximum deviation from average voltage.

(AB) 227-224 = 3 v

(BC) 231-227 = 4 v

(AC) 227-226 = 1 v

Maximum deviation is 4 v.

Determine percent of voltage imbalance.

$$\% \text{ Voltage Imbalance} = 100 \times \frac{4}{227} = 1.78\%$$

This amount of phase imbalance is satisfactory as it is below the maximum allowable 2%.

IMPORTANT: If the supply voltage phase imbalance is more than 2%, contact your local electric utility company immediately.

FIELD CONTROL WIRING

The 50HCQ unit requires an external temperature control device. This device can be a thermostat (field-supplied) or a PremierLink™ controller (available as factory-installed option or as field-installed accessory, for use on a Carrier Comfort Network® or as a stand-alone control) or the RTU Open Controller for Building Management Systems using non-CCN protocols (RTU Open is available as a factory-installed option only).

THERMOSTAT

Select a Carrier-approved accessory 2-stage Cooling/Heating thermostat. The 50HCQ models do not require a thermostat with an O function to control the reversing valve operation. If using an electronic thermostat, configure it for “non-heat pump” operation. Install the accessory thermostat according to installation instructions included with the accessory.

Locate the thermostat accessory on a solid wall in the conditioned space to sense average temperature in accordance with the thermostat installation instructions.

If the thermostat contains a logic circuit requiring 24-v power, use a thermostat cable or equivalent single leads of different colors with minimum of seven leads. If the thermostat does not require a 24-v source (no “C” connection required), use a thermostat cable or equivalent with minimum of six leads. See Fig. 27. Check the thermostat installation instructions for additional features which might require additional conductors in the cable.

For wire runs up to 50 ft. (15 m), use no. 18 AWG (American Wire Gage) insulated wire [35°C (95°F) minimum]. For 50 to 75 ft. (15 to 23 m), use no. 16 AWG insulated wire [35°C (95°F) minimum]. For over 75 ft. (23 m), use no. 14 AWG insulated wire [35°C (95°F) minimum]. Wire sizes larger than no. 18 AWG cannot be directly connected to the thermostat and will require a junction box and splice at the thermostat.

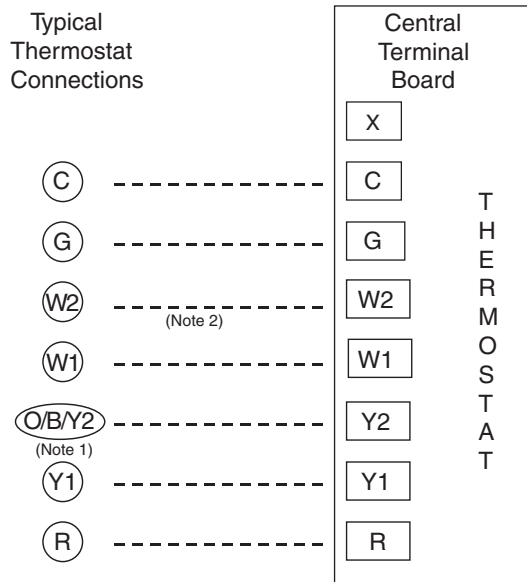

Fig. 27 — Typical Low-Voltage Control Connections

Thermostat Wiring, Units Without Thru-Base Connection Kit

Pass the thermostat control wires through the hole provided in the corner post; then feed the wires through the raceway built into the corner post to the control box. Pull the wires over to the terminal strip on the upper-left corner of the Controls Connection Board. See Fig. 28.

NOTE: If thru-the-bottom connections accessory is used, refer to the accessory installation instructions for information on routing power and control wiring.

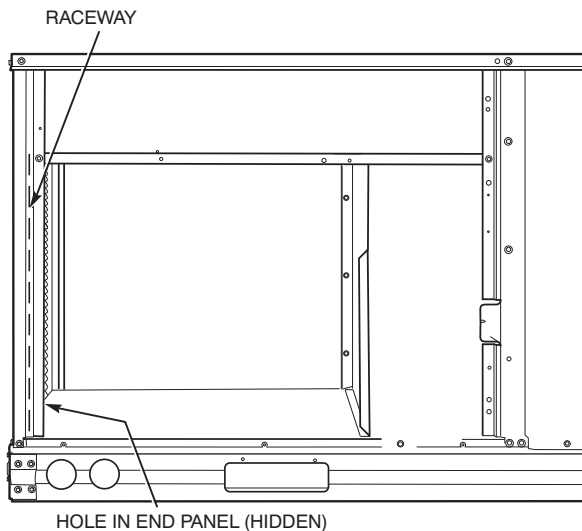

Fig. 28 — Field Control Wiring Raceway

HEAT ANTICIPATOR SETTINGS

Set heat anticipator settings at 0.14 amp for the first stage and 0.14 amp for second-stage heating, when available.

COMMERCIAL DEFROST CONTROL

The Commercial Defrost Control Board (DFB) coordinates thermostat demands for supply fan control, 1 or 2 stage cooling, 2 stage heating, emergency heating and defrost control with unit operating sequences. The DFB also provides an indoor fan off delay feature (user selectable). See Fig. 29 for board arrangement.

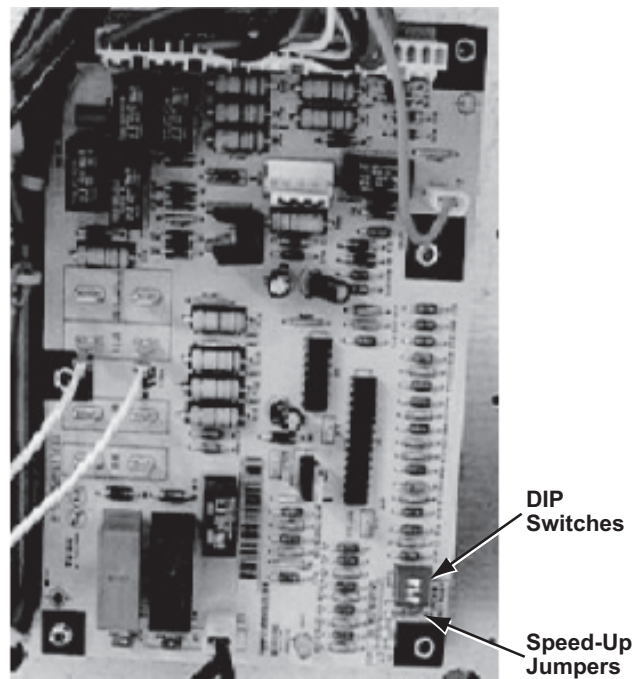

Fig. 29 — Defrost Control Board Arrangement

The DFB is located in the 50HCQ unit's main control box (see Fig. 30). All connections are factory-made through harnesses to the unit's CTB, to IFC (belt-drive motor) or to ECM (direct-drive motor), reversing valve solenoids and to defrost thermostats. Refer to Table 3 for details of DFB Inputs and Outputs.

Reversing valve control

The DFB has two outputs for unit reversing valve control. Operation of the reversing valves is based on internal logic; this application does not use an "O" or "B" signal to determine reversing valve position. Reversing valves are energized during the cooling stages and the defrost cycle and de-energized during heating cycles. Once energized at the start of a cooling stage, the reversing valve will remain energized until the next heating cycle demand is received. Once de-energized at the start of a Heating cycle, the reversing valves will remain de-energized until the next cooling stage is initiated.

Compressor control

The DFB receives inputs indicating Stage 1 Cooling, Stage 2 Cooling and Stage 1 Heating from the space thermostat or unit control system (PremierLink™ controller or RTU Open controller); it generates commands to start compressors with or without reversing valve operation to produce Stage 1 Cooling (one compressor runs), Stage 2 Cooling (both compressors run) or Stage 1 Heating (both compressors run).

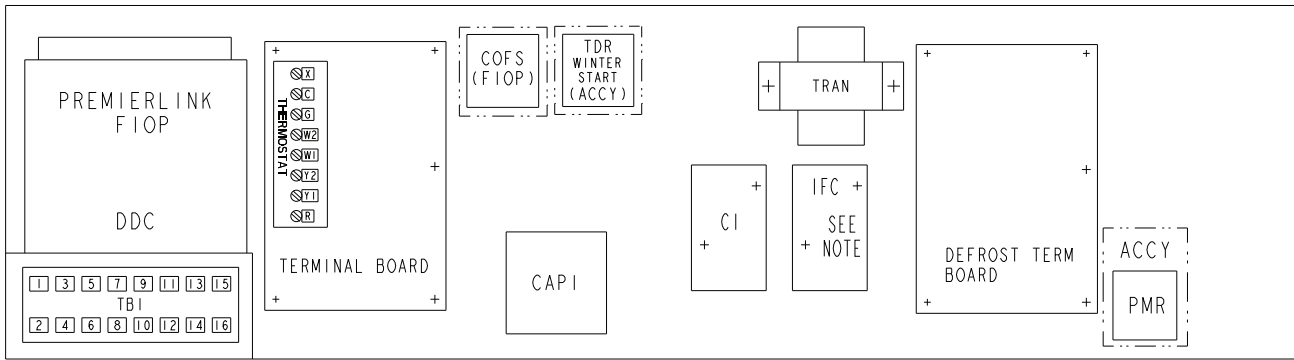

NOTE: IFC ONLY FOR 3Ø IFM, IFC NOT REQUIRED FOR DIRECT DRIVE MOTOR OPTION.

Fig. 30 — Defrost Control Board Location

Table 3 — 50HCQ Defrost Board I/O and Jumper Configurations

POINT NAME	TYPE OF I/O	CONNECTION PIN NUMBER	UNIT CONNECTION	NOTE
INPUTS				
G Fan	DI, 24 vac	P2-3	CTB-G	
Y1 Cool 1	DI, 24 vac	P2-5	CTB-Y1	
Y2 Cool 2	DI, 24 vac	P2-4	CTB-Y2	
W1 Heat 1	DI, 24 vac	P2-7	CTB-W1	
W2 Heat 2	DI, 24 vac	P2-6	CTB-W2	
R Power	24 vac	P3-1	CONTL BRD-8	
C Common	24 vac	P3-2	CONTL BRD-4	
DFT 1	DI, 24 vac	DFT-1 to DFT-1	—	
DFT 2	DI, 24 vac	DFT-2 to DFT-2	—	
OUTPUTS				
IFO Fan On	DO, 24 vac	P3-9	REHEAT/HP-2	
OF OD Fan On	DO, 24 vac	OF	OFR	
RVS1	DO, 24 vac	P3-7 to P3-5	—	Energize in COOL
RVS2	DO, 24 vac	P3-6 to P3-4	—	Energize in COOL
COMP 1	DO, 24 vac	P3-10	FPT1-REHEAT/HP-6	
COMP2	DO, 24 vac	P3-8	FPT2-REHEAT/HP-8	
HEAT 2	DO, 24 vac	E-HEAT	TB4-1	
COM	24 vac	P3-3	TB4-3	
CONFIGURATION				
Select Jumper	24 vac	P1-1	—	
2 Compressor	24 vac	P1-3	—	Use for 50TCQD
SPEED-UP CONFIGURATION				
Speed-Up Jumper	—	JMP17	—	
Speed-Up Jumper	—	JMP18	—	

NOTES:

1. Jumper for 1-3 seconds: Factory Test — The defrost interval timing is reduced by a factor of 0.1 seconds/minute based on the positions of DIP switches SW1 and SW2 (i.e. 90 minutes will be reduced to 9 seconds).

2. Jumper for 5-20 seconds: Forced Defrost — Defrost runs for 30 seconds if DFT2 is open.

Table 4 — DIP Switch Positions

	1	2		1	2		1	2		1	2		3	
1	•		1	•		1	•		1	•	•	1	•	On
0		•	0	•		0	•	•	0			0		Off
	30 minutes (factory default)			60 minutes			90 minutes			120 minutes			Fan Delay	

Auxiliary (Electric) Heat control

The 50HCQ unit can be equipped with one or two auxiliary electric heaters, to provide a second stage of heating. The DFB will energize this Heating System for a Stage 2 Heating Command (heaters operate concurrently with compressor(s) in the Stage 1 Heating cycle), for an Emergency Heating sequence (compressors are off and only the electric heaters are energized) and also during the Defrost cycle (to eliminate a “cold blow” condition in the space).

Defrost

The defrost control mode is a time/temperature sequence. There are two time components: The continuous run period and the test/defrost cycle period. The temperature component is provided by Defrost Thermostat 1 and 2 (DFT1 and DFT2) mounted on the outdoor coil.

The continuous run period is a fixed time period between the end of the last defrost cycle (or start of the current Heating cycle) during which no defrost will be permitted. This period can be set at 30, 60, 90 or 120 minutes by changing the positions of DIP switches SW1 and SW2 (see Fig. 31 and Table 4). The default run period is 30 minutes.

Shorting the jumpers for a period of 5 to 20 seconds bypasses the remaining continuous run period and places the unit in a Forced Defrost mode. If the controlling DFT is closed when this mode is initiated, the unit will complete a normal defrost period that will terminate when the controlling DFT opens or the 10 minute defrost cycle limit is reached. If the controlling DFT is open when this mode is initiated, the Defrost cycle will run for 30 seconds. Both modes end at the end of the Defrost cycle.

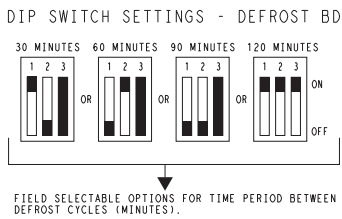

Fig. 31 — DIP Switch Settings - Defrost Board

ELECTRIC HEATERS

50HCQ units may be equipped with field-installed accessory electric heaters. The heaters are modular in design, with heater frames holding open coil resistance wires strung through ceramic insulators, line-break limit switches and a control contactor. One or two heater modules may be used in a unit.

Heater modules are installed in the compartment below the indoor (supply) fan outlet. Access is through the indoor access panel. Heater modules slide into the compartment on tracks along the bottom of the heater opening. See Fig. 32-34.

Not all available heater modules may be used in every unit. Use only those heater modules that are UL listed for use in a specific size unit. Refer to the label on the unit cabinet for the list of approved heaters.

Unit heaters are marked with Heater Model Numbers, but heaters are ordered as and shipped in cartons marked with a corresponding heater Sales Package part number. See Table 5 for correlation between Heater Model Number and Sales Package part number.

NOTE: The value in position 9 of the part number differs between the sales package part number (value is 1) and a bare heater model number (value is 0).

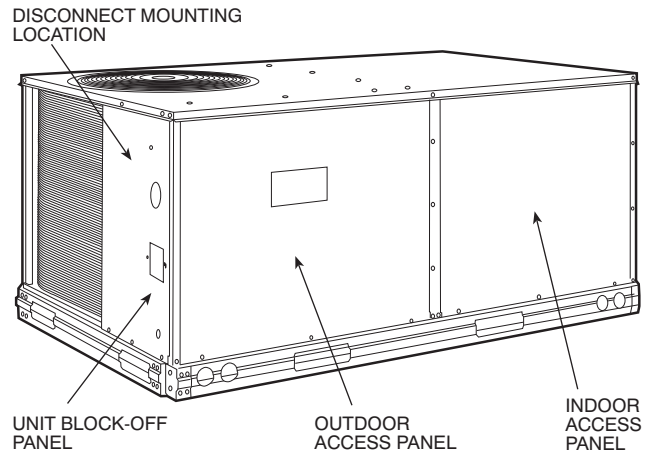

Fig. 32 — Typical Access Panel Location

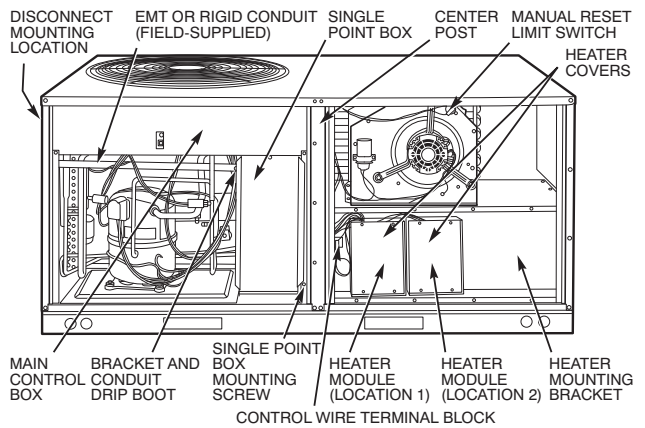

Fig. 33 — Typical Component Location

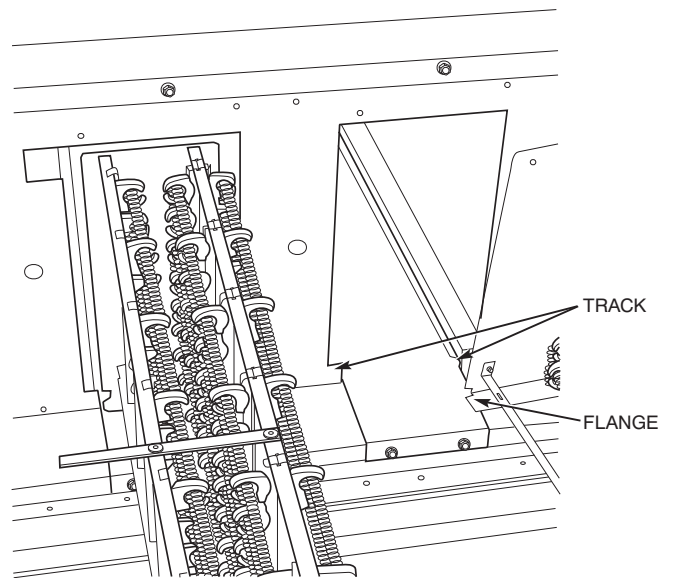

Fig. 34 — Typical Module Installation

Single Point Boxes and Supplementary Fuses

When the unit MOCB device value exceeds 60-A, unit-mounted supplementary fuses are required for each heater circuit. These fuses are included in accessory single point boxes, with power distribution and fuse blocks. The single point box will be installed directly under the unit control box, just to the left of the partition separating the indoor section (with electric heaters) from the outdoor section. The single point box has a hinged access cover. See Fig. 35. The single point box also includes a set of power taps and pigtailed to complete the wiring between the single point box and the unit's main control box terminals. Refer to the accessory heater and single point box installation instructions for details on tap connections on the field-installed electric heat accessory.

All fuses on 50HCQ units are 60-A. (Note that all heaters are qualified for use with a 60-A fuse, regardless of actual heater ampacity, so only 60-A fuses are necessary.)

Single Point Boxes without Fuses

Refer to accessory heater and single point box installation instructions for details on tap connections.

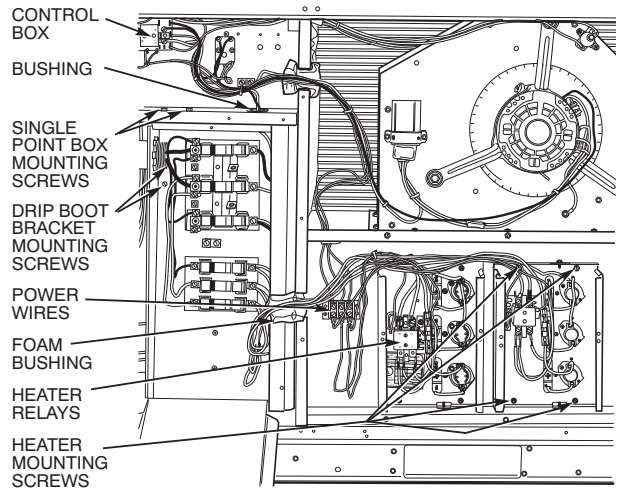

Fig. 35 — Typical Single Point Installation

Table 5 — Heater Model Number

BARE HEATER MODEL NUMBER	C	R	H	E	A	T	E	R	0	0	1	A	0	0
Heater Sales Package P/N includes:									0	0	1	A	0	0
Bare Heater Carton and packing materials Installation sheet	C	R	H	E	A	T	E	R	1	0	1	A	0	0

Low Voltage Control Connections

Run the low-voltage control leads from the heater module(s) — VIO and BRN (two of each if two modules are installed; identify for Module #1) — to the 4-pole terminal board TB4 located on the heater bulkhead to the left of Heater #1. Connect the VIO leads from Heater #1 and Heater #2 to terminal TB4-1. Connect the BRN leads to terminal TB4-3. See Fig. 36.

CONTROL AND POWER WIRING DIAGRAMS

Figures 37-44 are typical control and power wiring diagrams.

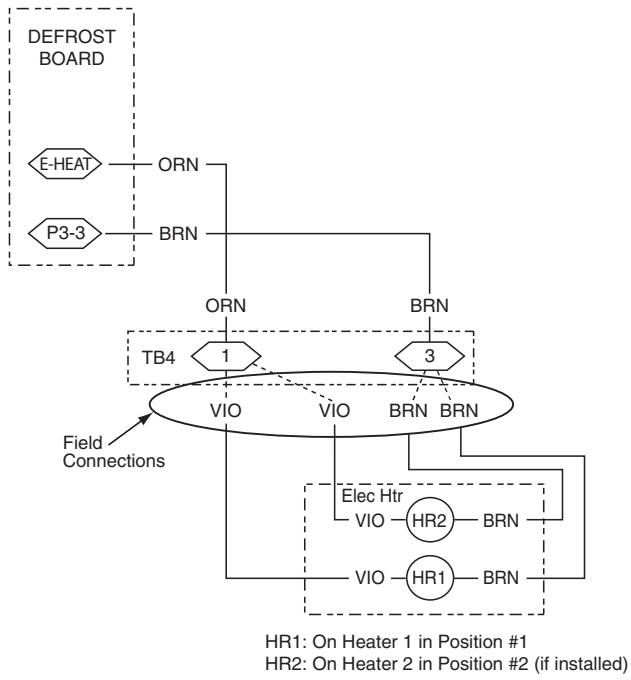
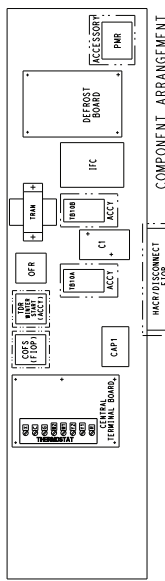
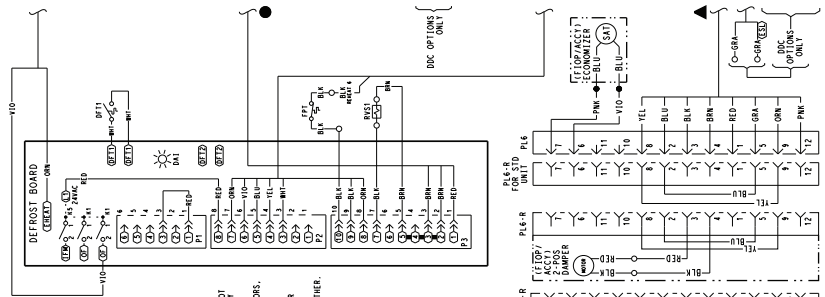
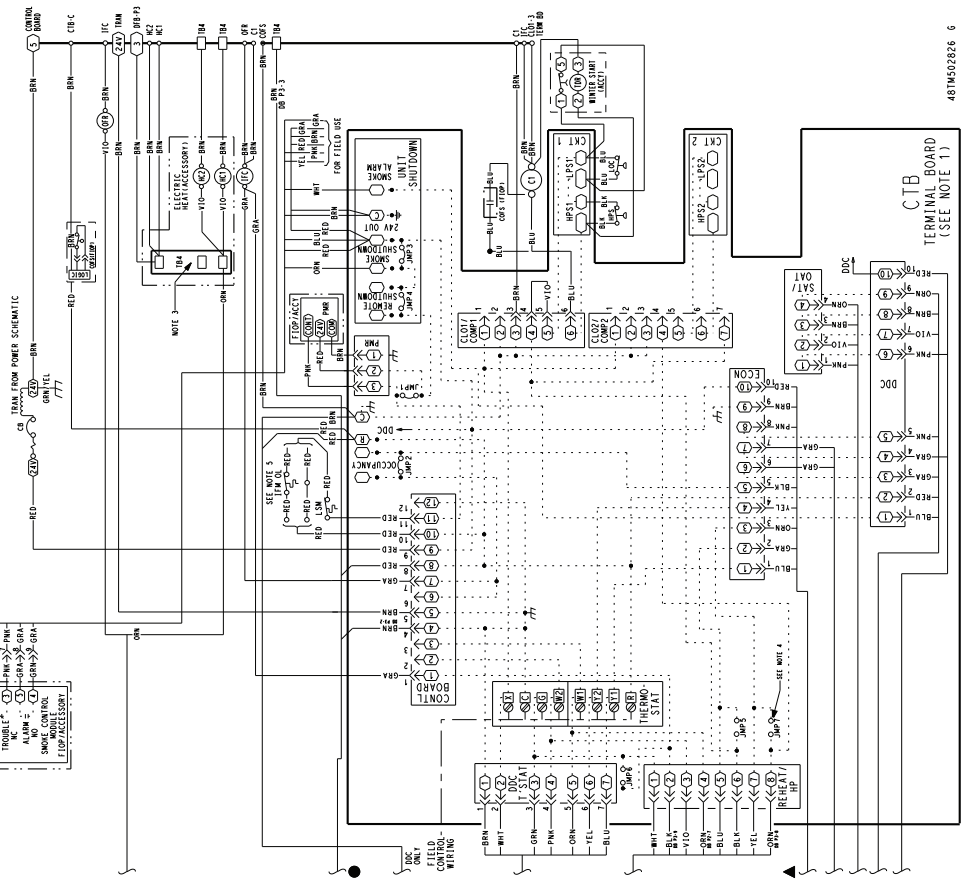
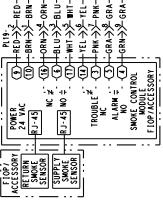
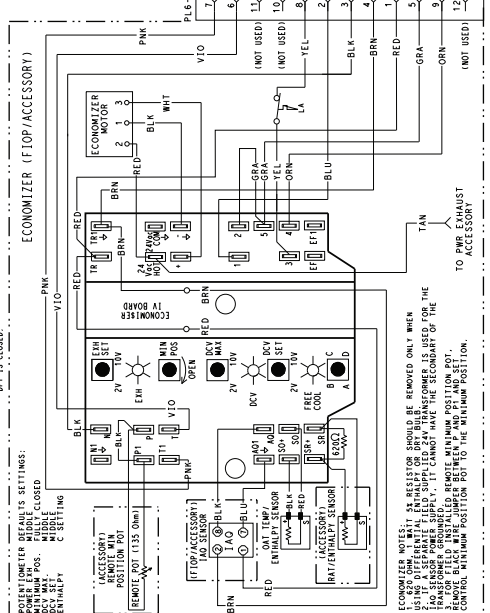

Fig. 36 — Accessory Electric Heater Control Connections

HEAT PUMP CONTROL 208/230V, 460V, 575V TIER 2 (1) COMPRESSOR



1. TERMINAL BOARD SCHEMATIC LAYOUT DOES NOT NECESSARILY REFLECT THE PHYSICAL ARRANGEMENT OF THE COMPONENTS.
2. ENSURE DISCONNECTED JUMPS ON TERMINAL BOARDS.
3. PHASE LOSS RELAY, OCCUPANCY AND REMOTE CONTROL MUST BE LOCATED IN HEAT SECTION.
4. HEAT PUMP OPERATION MUST BE DISABLED FOR DEFROST. DEFROST WILL TERMINATE IN 30 SEC. IF DEFROST TIMER TERMINATE NORMALLY IF DEFROST TIMER IS CLOSED.
5. NOT USED. RED LEADS ARE CONNECTED TOGETHER.



- ECONOMIZER NOTES:**
1. A RESISTOR SHOULD BE REMOVED ONLY WHEN USED WITH A 24V TRANSFORMER.
 2. A 24V TRANSFORMER SHOULD BE USED FOR THE ECONOMIZER MOTOR POS POSITION POT.
 3. A 24V TRANSFORMER SHOULD BE USED FOR THE ECONOMIZER MOTOR POS POSITION POT.
 4. A 24V TRANSFORMER SHOULD BE USED FOR THE ECONOMIZER MOTOR POS POSITION POT.

Fig. 37 — Electro-Mechanical Control Wiring: 50HCQ*A07/D07 — 208/230v, 460v, 575v

HEAT PUMP CONTROL 208/230V, 460V, 575V
6TON 2-STG COOLING 1-COMPR MID-TIER

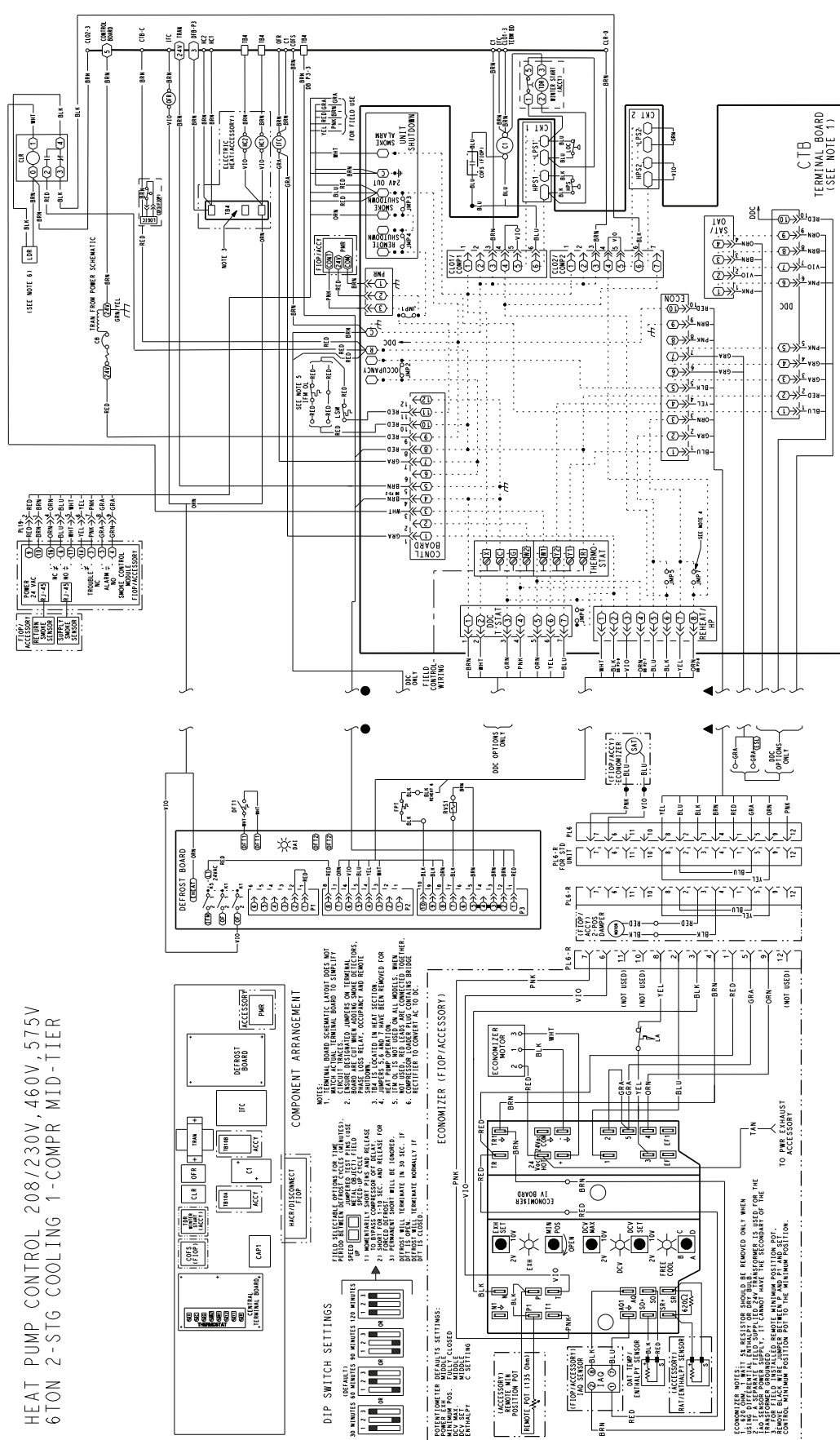

487MD2931 X

Fig. 38 — Electro-Mechanical Control Wiring: 50HCQ-D07 Tier 2 (1) Compressor — 208/230v, 460v, 575v

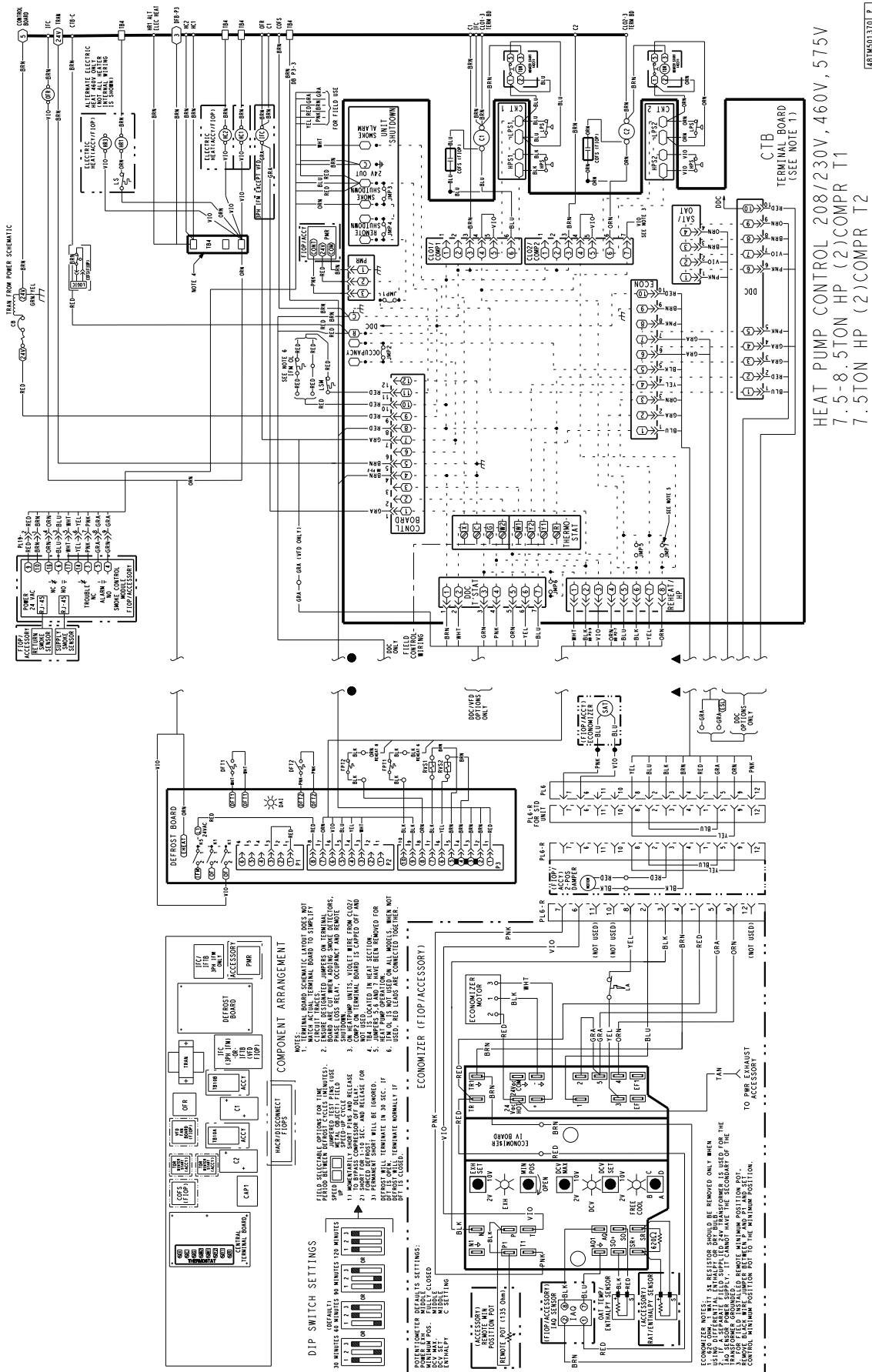

Fig. 39 — Electro-Mechanical Control Wiring: 50HCQ*08/09 — 208/230v, 460v, 575v

HP POWER 208/230V, 460V, 575V 3 PH (1) COMPRESSOR

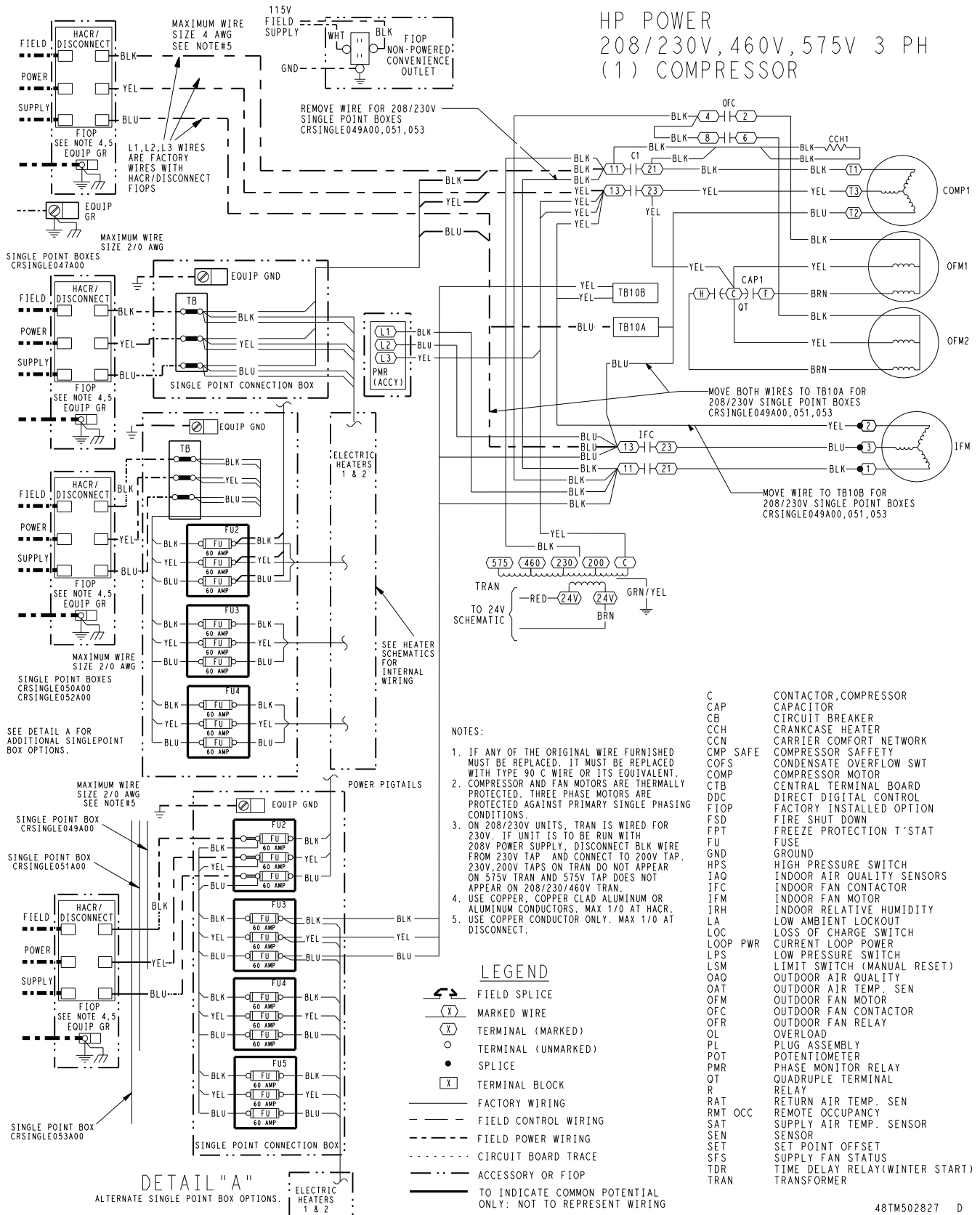
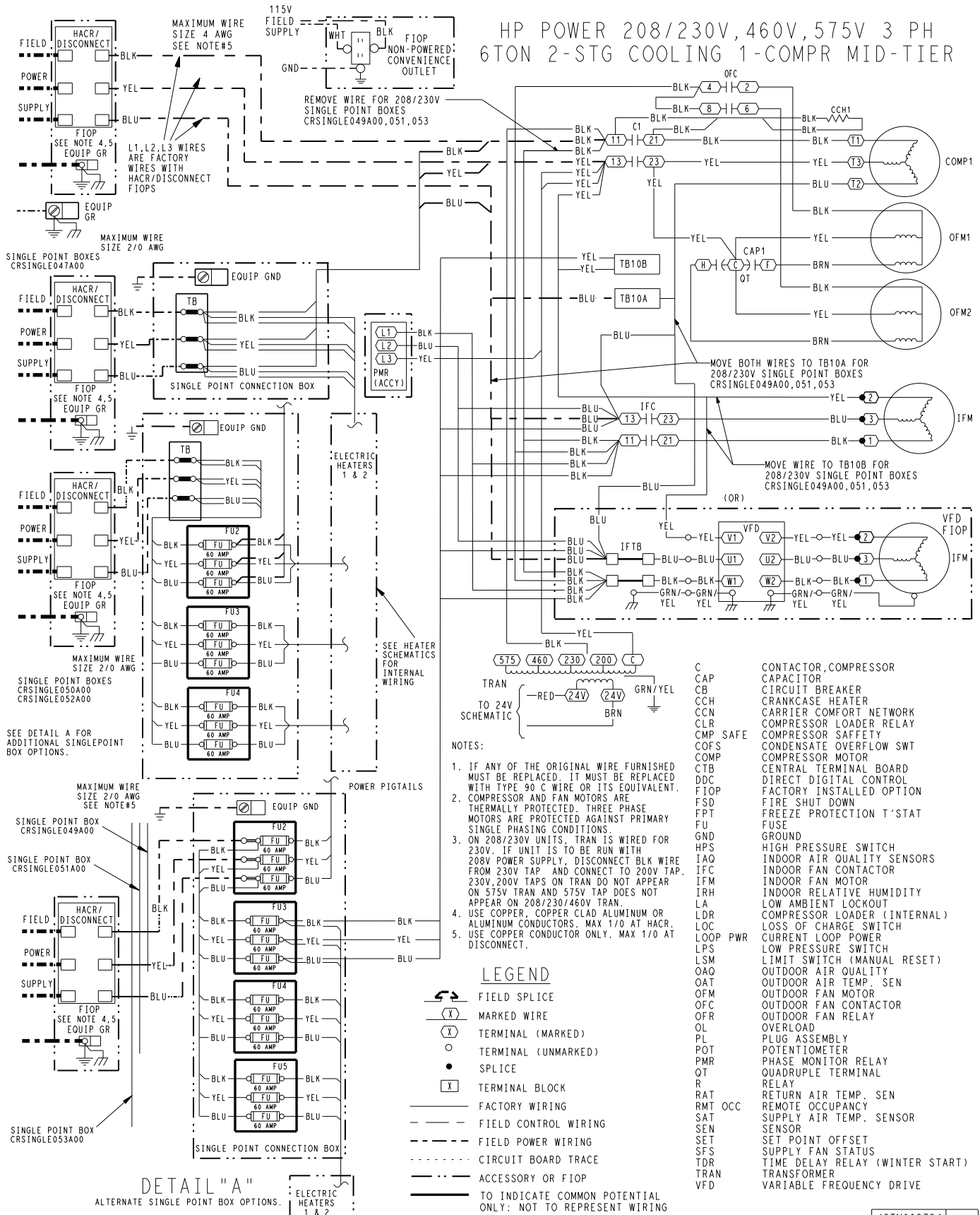

Fig. 40 — Electro-Mechanical Power Wiring: 50HC*A07/D07 — 208/230v, 460v, 575v

HP POWER 208/230V, 460V, 575V 3 PH
6TON 2-STG COOLING 1-COMPR MID-TIER



- LEGEND
- FIELD SPICE
 - MARKED WIRE
 - TERMINAL (MARKED)
 - TERMINAL (UNMARKED)
 - SPLICE
 - TERMINAL BLOCK
 - FACTORY WIRING
 - FIELD CONTROL WIRING
 - FIELD POWER WIRING
 - CIRCUIT BOARD TRACE
 - ACCESSORY OR FIOP
 - TO INDICATE COMMON POTENTIAL ONLY; NOT TO REPRESENT WIRING
- NOTES:
- IF ANY OF THE ORIGINAL WIRE FURNISHED MUST BE REPLACED. IT MUST BE REPLACED WITH TYPE 90 C WIRE OR ITS EQUIVALENT.
 - COMPRESSOR AND FAN MOTORS ARE THERMALLY PROTECTED. THREE PHASE MOTORS ARE PROTECTED AGAINST PRIMARY SINGLE PHASING CONDITIONS.
 - ON 208/230V UNITS, TRAN IS WIRED FOR 230V. IF UNIT IS TO BE RUN WITH 208V POWER SUPPLY, DISCONNECT BLK WIRE FROM 230V TAP AND CONNECT TO 200V TAP. 230V, 200V TAPS ON TRAN DO NOT APPEAR ON 575V TRAN AND 575V TAP DOES NOT APPEAR ON 208/230/460V TRAN.
 - USE COPPER, COPPER CLAD ALUMINUM OR ALUMINUM CONDUCTORS. MAX 1/0 AT HACR.
 - USE COPPER CONDUCTOR ONLY. MAX 1/0 AT DISCONNECT.
- TRAN TO 24V SCHEMATIC
- 575 460 230 200 C
- RED 24V 24V GRN/YEL BRN
- LEGEND (continued):
- C CONTACTOR, COMPRESSOR
 - CAP CAPACITOR
 - CB CIRCUIT BREAKER
 - CCH CRANKCASE HEATER
 - CCN CARRIER COMFORT NETWORK
 - CLR COMPRESSOR LOADER RELAY
 - CMP COMPRESSOR SAFETY
 - COFS CONDENSATE OVERFLOW SWT
 - COMP COMPRESSOR MOTOR
 - CTB CENTRAL TERMINAL BOARD
 - DDC DIRECT DIGITAL CONTROL
 - FIOP FACTORY INSTALLED OPTION
 - FSD FIRE SHUT DOWN
 - FPT FREEZE PROTECTION T'STAT
 - FU FUSE
 - GND GROUND
 - HPS HIGH PRESSURE SWITCH
 - IAQ INDOOR AIR QUALITY SENSORS
 - IFC INDOOR FAN CONTACTOR
 - IFM INDOOR FAN MOTOR
 - IRH INDOOR RELATIVE HUMIDITY
 - LA LOW AMBIENT LOCKOUT
 - LDR COMPRESSOR LOADER (INTERNAL)
 - LOC LOSS OF CHARGE SWITCH
 - LOOP PWR CURRENT LOOP POWER
 - LPS LOW PRESSURE SWITCH
 - LSM LIMIT SWITCH (MANUAL RESET)
 - OAO OUTDOOR AIR QUALITY
 - OAT OUTDOOR AIR TEMP. SEN
 - OFM OUTDOOR FAN MOTOR
 - OFC OUTDOOR FAN CONTACTOR
 - OFR OUTDOOR FAN RELAY
 - OL OVERLOAD
 - PL PLUG ASSEMBLY
 - POT POTENTIOMETER
 - PMR PHASE MONITOR RELAY
 - QT QUADRUPLE TERMINAL
 - R RELAY
 - RAT RETURN AIR TEMP. SEN
 - RMT OCC REMOTE OCCUPANCY
 - SAT SUPPLY AIR TEMP. SENSOR
 - SEN SENSOR
 - SET SET POINT OFFSET
 - SFS SUPPLY FAN STATUS
 - TDR TIME DELAY RELAY (WINTER START)
 - TRAN TRANSFORMER
 - VFD VARIABLE FREQUENCY DRIVE

48TM002724 -

Fig. 41 — Electro-Mechanical Power Wiring: 50HCQ*D07 Tier 2 (1) Compressor — 208/230v, 460v, 575v

HP POWER 208/230V, 460V, 575V 3 PH. 7.5-8.5TON HP (1)COMPR T1
7.5TON HP (1)COMPR T2

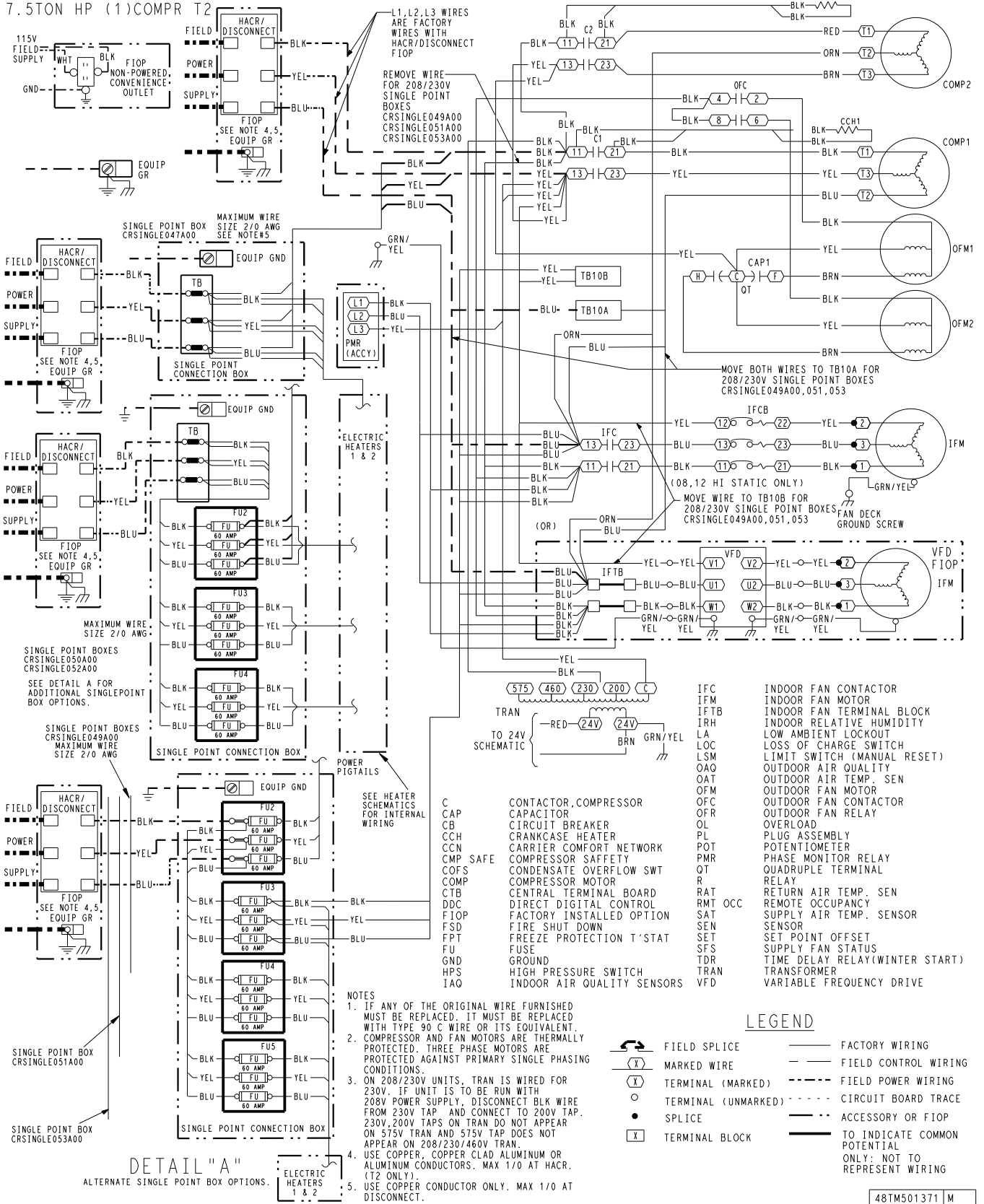
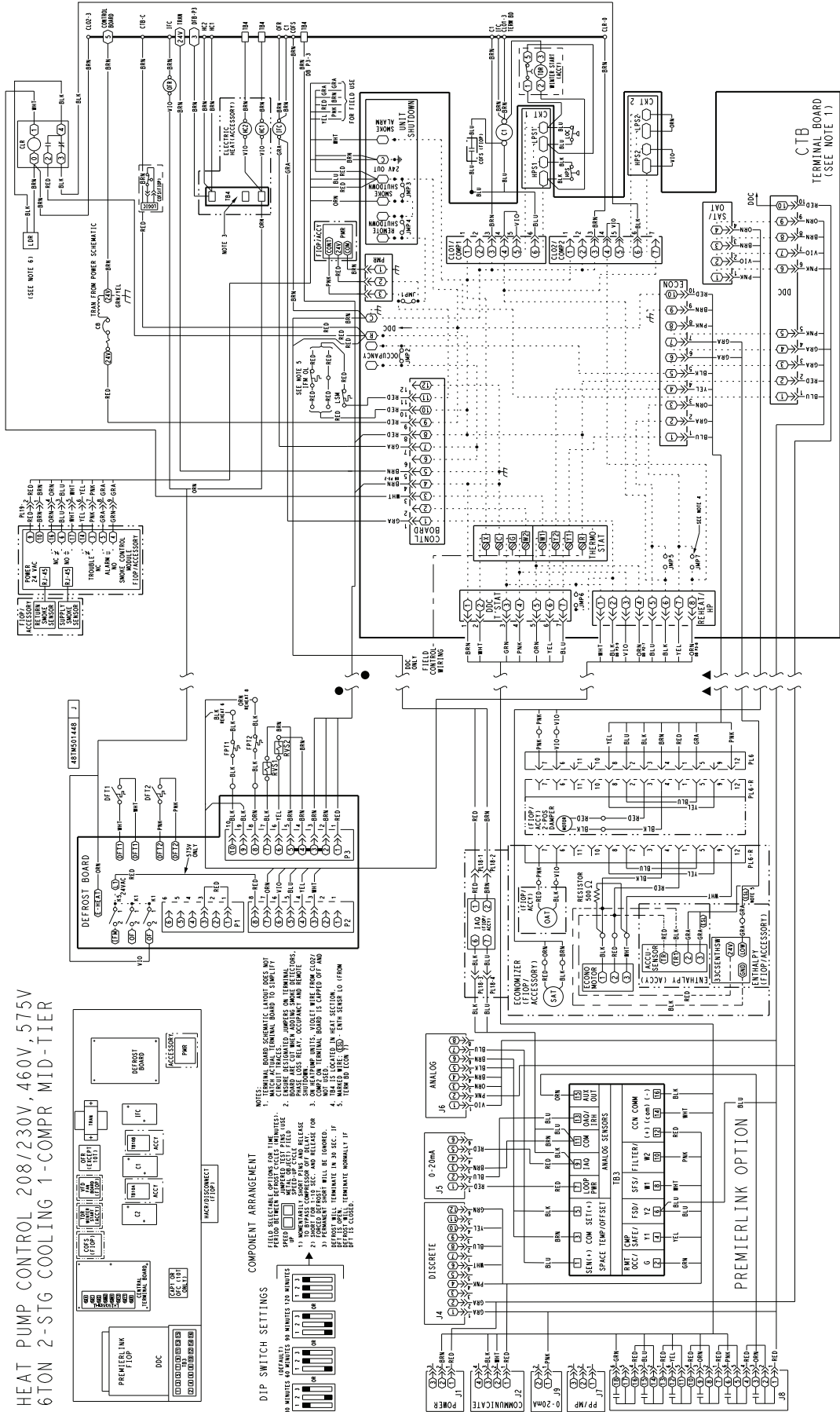

Fig. 42 — Electro-Mechanical Power Wiring: 50HCQ*08/09 — 208/230v, 460v, 575v

48TM501371 M

HEAT PUMP CONTROL 208/230V, 460V, 575V
6TON 2-STG COOLING 1-COMPR MID-TIER



461W02691

Fig. 43 — PremierLink™ Wiring Schematic: 50HCQ07-09 — 208/230v, 460v, 575v

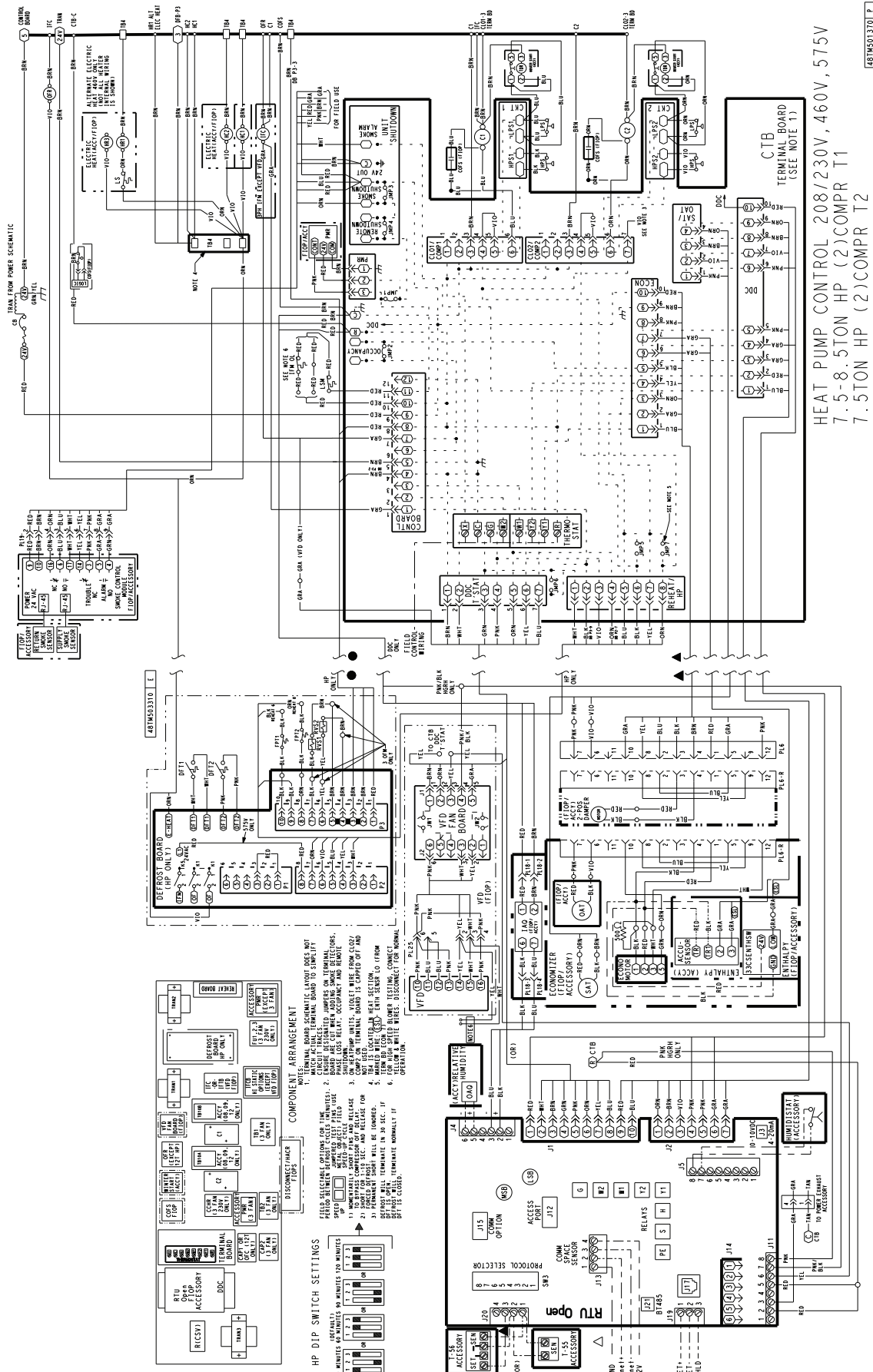

Fig. 44 — RTU Open System Control Wiring

ECONOMISER® (FACTORY OPTION)

The EconoMiSer X system is an expandable economizer control system, which includes a W7220 economizer module (controller) with an LCD and keypad (see Fig. 45). The W7220 can be configured with optional sensors.



Fig. 45 — W7220 Economizer Module

The W7220 economizer module can be used as a stand-alone economizer module wired directly to a commercial set-back space thermostat and sensors to provide outside air dry-bulb economizer control.

The W7220 economizer module can be connected to optional sensors for single or differential enthalpy control. The W7220 economizer module provides power and communications for the sensors.

The W7220 economizer module automatically detects sensors by polling to determine which sensors are present. If a sensor loses communications after it has been detected, the W7220 economizer controller indicates a device fail error on its LCD.

System Components

The EconoMiSer X system includes an economizer module, 20k mixed air sensor, damper actuator, and either a 20k outdoor air temperature sensor or S-Bus enthalpy sensors.

Economizer Module

The module is the core of the EconoMiSer X system. The module is mounted in the unit's control box, and includes the user interface for the system. The W7220 economizer module provides the basic inputs and outputs to provide simple economizer control. When used with the optional sensors, the economizer module provides more advanced economizer functionality.

S-Bus Enthalpy Control Sensors

The sensor is a combination temperature and humidity sensor which is powered by and communicates on the S-Bus. Up to three sensors may be configured with the W7220 economizer module.

CO₂ Sensor (optional)

The sensor can be added for Demand Controlled Ventilation (DCV).

Specifications

W7220 Economizer Module

The module is designed for use with 2 to 10 Vdc or bus communicating actuator. The module includes terminals for CO₂ sensor, Mixed Air sensor, and an Outdoor Dry Bulb sensor. Enthalpy and other options are available with bus sensors.

User Interface

The interface provides status for normal operation, setup parameters, checkout tests, and alarm and error conditions with a 2-line 16 character LCD display and four button keypad.

Electrical

- Rated Voltage — 20 to 30 Vac RMS, 50/60 Hz
- Transformer — 100 va maximum system input
- Nominal Power Consumption (at 24 Vac, 60 Hz) — 11.5 VA without sensors or actuators
- Relay Digital Output Rating at 30 Vac (maximum power from Class 2 input only) — 1.5A run; 3.5A inrush at 0.45PF (200,000 cycles) or 7.5A inrush at 0.45PF (100,000 cycles)
- External Sensors Power Output — 21 Vdc \pm 5% at 48mA

IMPORTANT: All inputs and outputs must be Class 2 wiring.

Inputs

Sensors

NOTE: A Mixed Air (MA) analog sensor is required on all W7220 units; either an Outdoor Air (OA) sensor for dry bulb change over or an OA bus sensor for outdoor enthalpy change over is required in addition to the MA sensor. An additional Return Air (RA) bus sensor can be added to the system for differential enthalpy or dry bulb changeover. For differential dry bulb changeover a 20k ohm sensor is required in the OA and a bus sensor in the RA. DIP switch on RA bus sensor must be set in the RA position.

Dry Bulb Temperature (optional) and Mixed Air (required), 20k NTC

2-wire (18 to 22 AWG)

Temperature range -40 to 150°F (-40 to 65°C)

Temperature accuracy $-0^{\circ}\text{F}/+2^{\circ}\text{F}$

Temperature and Humidity, C7400S1000 (optional)

S-Bus; 2-wire (18 to 22 AWG)

Temperature: range -40 to 150°F (-40 to 65°C)

Temperature accuracy $-0^{\circ}\text{F}/+2^{\circ}\text{F}$

Humidity: range 0 to 100% RH with 5% accuracy.

NOTE: Up to three (3) S-Bus sensors may be connected to the W7220 economizer module. For outdoor air (OA), return air (RA) and discharge (supply) air (DA).

4 Binary Inputs — 1-wire 24 Vac + common GND (see Fig. 46 for wiring details).

24 Vac power supply — 20 to 30 Vac 50/60Hz; 100 VA Class 2 transformer.

Outputs

Actuator Signal

2-10 Vdc; minimum actuator impedance is 2k ohm; bus two-wire output for bus communicating actuators.

Exhaust fan, Y1, Y2 and AUX1 O

All Relay Outputs (at 30 Vac):

Running: 1.5A maximum

Inrush: 7.5A maximum

Environmental

Operating Temperature

-40 to 150°F (-40 to 65°C).

Exception of display operation down to -4°F with full recovery at -4°F from exposure to -40°F

Storage Temperature

-40 to 150°F (-40 to 65°C)

Shipping Temperature

-40 to 150°F (-40 to 65°C)

Relative Humidity

5% to 95% RH non-condensing

Economizer Module Wiring Details

Use Fig. 46 and Tables 6 and 7 to locate the wiring terminals for the Economizer module.

NOTE: The four terminal blocks are removable. Slide out each terminal block, wire it, and then slide it back into place.

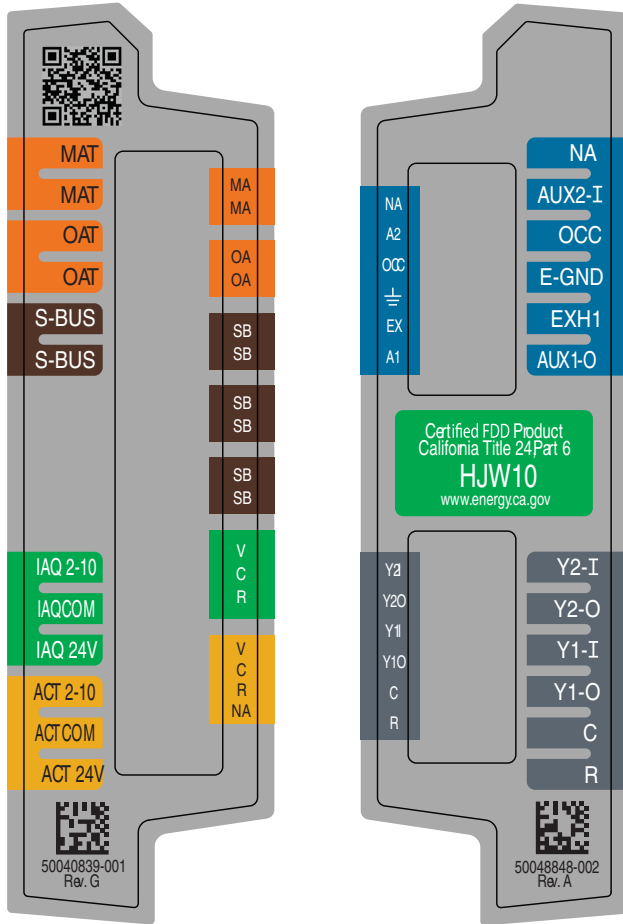

Fig. 46 — W7220 Wiring Terminals

Table 6 — Economizer Module - Left Hand Terminal Blocks

LABEL	TYPE	DESCRIPTION
Top Left Terminal Block		
MAT MAT	20k NTC and COM	Mixed Air Temperature Sensor (Polarity Insensitive Connection)
OAT OAT	20k NTC and COM	Outdoor Air Temperature Sensor (Polarity Insensitive Connection)
S-BUS S-BUS	S-BUS (Sylk* Bus)	Enthalpy Control Sensor (Polarity Insensitive Connection)
Bottom Left Terminal Block		
IAQ 2-10	2-10 VDC	Air Quality Sensor Input (e.g. CO ₂ sensor)
IAQ COM	COM	Air Quality Sensor Common
IAQ 24V	24 VAC	Air Quality Sensor 24 VAC Source
ACT 2-10	2-10 VDC	Damper Actuator Output (2-10 VDC)
ACT COM	COM	Damper Actuator Output Common
ACT 24v	24 VAC	Damper Actuator 24 VAC Source

* Sylk is a trademark of Honeywell International Inc.

Table 7 — Economizer Module - Right Hand Terminal Blocks

LABEL	TYPE	DESCRIPTION
Top Right Terminal Blocks		
AUX2 I	24 VAC IN	The first terminal is not used.
OCC	24 VAC IN	Shut Down (SD) or HEAT (W) Conventional only and Heat Pump Changeover (O-B) in Heat Pump mode.
E-GND	E-GND	Occupied/Unoccupied Input
EXH1	24 VAC OUT	Exhaust Fan 1 Output
AUX1 O	24 VAC OUT	Programmable: Exhaust fan 2 output or ERV or System alarm output
Bottom Right Terminal Blocks		
Y2-I	24 VAC IN	Y2 in - Cooling Stage 2 Input from space thermostat
Y2-O	24 VAC OUT	Y2 out - Cooling Stage 2 Output to stage 2 mechanical cooling
Y1-I	24 VAC IN	Y1 in - Cooling Stage 2 Input from space thermostat
Y1-O	24 VAC OUT	Y1 out - Cooling Stage 2 Output to stage 2 mechanical cooling
C	COM	24 VAC Common
R	24 VAC	24 VAC Power (hot)

S-Bus Sensor Wiring

The labels on the sensors and controller are color coded for ease of installation. Orange labeled sensors can only be wired to orange terminals on the controller. Brown labeled sensors can only be wired to S-bus (brown) terminals. Use Fig. 47 and Table 8 to locate the wiring terminals for each S-Bus sensor.

Use Fig. 47 and Table 8 to locate the wiring terminals for each enthalpy control sensor.

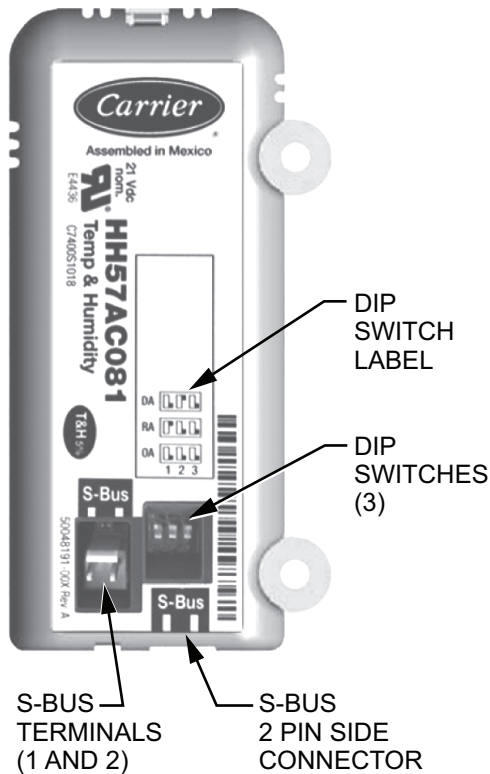

Fig. 47 — S-Bus Sensor DIP Switches

Table 8 — HH57AC081 Sensor Wiring Terminations

TERMINAL		TYPE	DESCRIPTION
NUMBER	LABEL		
1	S-BUS	S-BUS	S-BUS Communications (Enthalpy Control Sensor Bus)
2	S-BUS	S-BUS	S-BUS Communications (Enthalpy Control Sensor Bus)

Use Fig. 47 and Table 9 to set the DIP switches for the desired use of the sensor.

Table 9 — HH57AC081 Sensor DIP Switch

USE	DIP SWITCH POSITIONS FOR SWITCHES 1, 2, AND 3		
	1	2	3
DA	OFF	ON	OFF
RA	ON	OFF	OFF
OA	OFF	OFF	OFF

NOTE: When an S-Bus sensor is connected to an existing network, it will take 60 minutes for the network to recognize and auto-configure itself to use the new sensor.

During the 60-minute setup period, no alarms for sensor failures (except SAT) will be issued and no economizing function will be available.

CO₂ Sensor Wiring

When using a CO₂ sensor the black and brown common wires are internally connected and only one is connected to “IAQ COM” on the W7220 (see Fig. 46). Use the power from the W7220 to power the CO₂ sensor OR make sure the ground for the power supplies are common. See Fig. 48 for CO₂ sensor wiring.

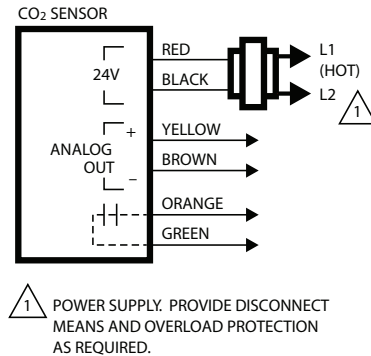

Fig. 48 — CO₂ Sensor Wiring

Interface Overview

This section describes how to use the EconoMiSer® user interface for:

- Keypad and menu navigation
- Settings and parameter changes
- Menu structure and selection

User Interface

The user interface consists of a 2-line LCD display and a 4-button keypad on the front of the economizer controller.

Keypad

Use the four navigation buttons (see Fig. 49) to scroll through the menus and menu items, select menu items, and to change parameter and configuration settings.

To use the keypad when working with menus:

- Press the ▲ (Up arrow) button to move to the previous menu.
- Press the ▼ (Down arrow) button to move to the next menu.
- Press the ↵ (Enter) button to display the first item in the currently displayed menu.
- Press the ⏴ (Menu Up/Exit) button to exit a menu’s item and return to the list of menus.

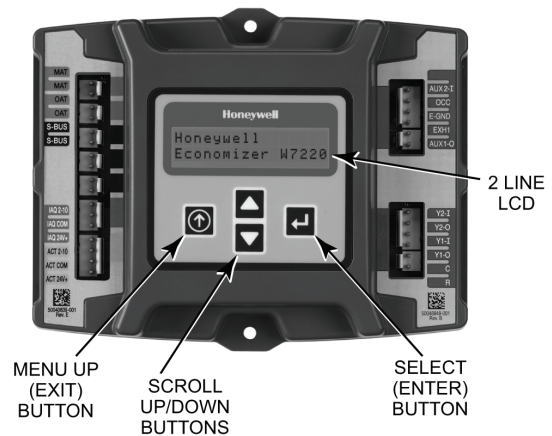

Fig. 49 — W7220 Controller Navigation Buttons

To use the keypad when working with Setpoints, System and Advanced Settings, Checkout tests and Alarms:

1. Navigate to the desired menu.
2. Press the \leftarrow (Enter) button to display the first item in the currently displayed menu.
3. Use the \blacktriangle and \blacktriangledown buttons to scroll to the desired parameter.
4. Press the \leftarrow (Enter) button to display the value of the currently displayed item.
5. Press the \blacktriangle button to increase (change) the displayed parameter value.
6. Press the \blacktriangledown button to decrease (change) the displayed parameter value.

NOTE: When values are displayed, pressing and holding the \blacktriangle or \blacktriangledown button causes the display to automatically increment or decrement.

1. Press the \leftarrow (Enter) button to accept the displayed value and store it in nonvolatile RAM. "CHANGE STORED" displays.
2. Press the \leftarrow (Enter) button to return to the current menu parameter.
3. Press the \uparrow (Menu Up/Exit) button to return to the previous menu.

Menu Structure

Table 10 illustrates the complete hierarchy of menus and parameters for the EconoMiSer[®] X system.

The Menus in display order are:

- STATUS
- SETPOINTS
- SYSTEM SETUP
- ADVANCED SETUP
- CHECKOUT
- ALARMS

IMPORTANT: Table 10 illustrates the complete hierarchy. Your menu parameters may be different depending on your configuration.

For example if you do not have a DCV (CO₂) sensor, then none of the DCV parameters appear and only MIN POS will display. If you have a CO₂ sensor, the DCV MIN and DCV MAX will appear.

NOTE: Some parameters in the menus use the letters MA or MAT, indicating a mixed air temperature sensor location before the cooling coil. This unit application has the control sensor located after the cooling coil, in the fan section, where it is designated as (Cooling) Supply Air Temperature or SAT sensor.

Setup and Configuration

Before being placed into service, the W7220 Economizer module must be set up and configured for the installed system.

IMPORTANT: During setup, the economizer module is live at all times.

The setup process uses a hierarchical menu structure that is easy to use. Press the \blacktriangle and \blacktriangledown arrow buttons to move forward and backward through the menus and press the \leftarrow (Enter) button to select and confirm setup item changes.

Time-Out and Screensaver

When no buttons have been pressed for 10 minutes, the LCD displays a screen saver, which cycles through the Status items. Each Status items displays in turn and cycles to the next item after 5 seconds.

Table 10 — Menu Structure*

MENU	PARAMETER	PARAMETER DEFAULT VALUE	PARAMETER RANGE AND INCREMENT†	NOTES
STATUS	ECONO AVAIL	NO	YES/NO	FIRST STAGE COOLING DEMAND (Y1-IN) YES = economizing available; the system can use outside air for free cooling when required
	ECONOMIZING	NO	YES/NO	FIRST STAGE COOLING RELAY OUTPUT YES = outside air being used for 1 stage cooling
	OCCUPIED	NO	YES/NO	OCCUPIED YES = OCC signal received from space thermostat or unitary controller YES = 24 Vac on terminal OCC NO = 0 Vac on terminal OCC
	HEAT PUMP	N/A**	COOL HEAT	HEAT PUMP MODE Displays COOL or HEAT when system is set to heat pump (Non-conventional)
	COOL Y1—IN	OFF	ON/OFF	FIRST STAGE COOLING DEMAND (Y1-IN) Y1-I signal from space thermostat or unitary controller for cooling stage 1. ON = 24 Vac on terminal Y1-I OFF = 0 Vac on terminal Y1-I
	COOL Y1—OUT	OFF	ON/OFF	FIRST STAGE COOLING RELAY OUTPUT Cool stage 1 Relay Output to stage 1 mechanical cooling (Y1—OUT terminal)
	COOL Y2—IN	OFF	ON/OFF	SECOND STAGE COOLING DEMAND (Y2-IN) Y2-I signal from space thermostat our unitary controller for second stage cooling. ON = 24 Vac on terminal Y2-I OFF = 0 Vac on terminal Y2-I
	COOL Y2—OUT	OFF	ON/OFF	SECOND STAGE COOLING RELAY OUTPUT Cool Stage 2 Relay Output to mechanical cooling (Y2—OUT terminal)
	MA TEMP	___ . _ F	0 to 140 F	SUPPLY AIR TEMPERATURE, Cooling Mode Displays value of measured mixed air from MAT sensor. Displays ___ . _ F if not connected, short or out-of-range.
	DA TEMP	___ . _ F	0 to 140 F	DISCHARGE AIR TEMPERATURE, after Heating section Displays when Discharge Air sensor is connected and displays measured discharge temperature. Displays ___ . _ F if sensor sends invalid value, if not connected, short or out-of-range.
	OA TEMP	___ . _ F	-40 to 140 F	OUTSIDE AIR TEMP Displays measured value of outdoor air temperature. Displays ___ . _ F if sensor sends invalid value, short or out-of-range.
	OA HUM	__ %	0 to 100%	OUTSIDE AIR RELATIVE HUMIDITY Displays measured value of outdoor humidity from OA sensor. Displays __ % if not connected short, or out-of-range.
	RA TEMP	___ . _ F	0 to 140 F	RETURN AIR TEMPERATURE Displays measured value of return air temperature from RAT sensor. Displays ___ . _ F if sensor sends invalid value, if not connected, short or out-of-range
	RA HUM	__ %	0 to 100%	RETURN AIR RELATIVE HUMIDITY Displays measured value of return air humidity from RA sensor. Displays __ % if sensor sends invalid value, if not connected, short or out-of-range
	IN CO2	___ ppm	0 to 2000 ppm	SPACE/RETURN AIR CO ₂ Displays value of measured CO ₂ from CO ₂ sensor. Invalid if not connected, short or out-of-range
	DCV STATUS	N/A	ON/OFF	DEMAND CONTROLLED VENTILATION STATUS Displays ON if above setpoint and OFF if below setpoint, and ONLY if a CO ₂ sensor is connected.
	DAMPER OUT	2.0v	2.0 TO 10.0v	Displays voltage output to the damper actuator.
	ACT POS	N/A	0 to 100%	Displays actual position of outdoor air damper actuator

Table 10 — Menu Structure* (cont)

MENU	PARAMETER	PARAMETER DEFAULT VALUE	PARAMETER RANGE AND INCREMENT†	NOTES
STATUS (CONT)	ACT COUNT	N/A	1 to 65535	Displays number of times actuator has cycled. 1 cycles equals 180 deg. of actuator movement in any direction.
	ACTUATOR	N/A	OK/Alarm (on Alarm menu)	Displays ERROR if voltage or torque is below actuator range.
	EXH1 OUT	OFF	ON/OFF	EXHAUST STAGE 1 RELAY OUTPUT Output of EXH1 terminal: ON = relay closed OFF = relay open
	EXH2 OUT	OFF	ON/OFF	EXHAUST STAGE 2 RELAY OUTPUT Output of AUX terminal; displays only if AUX = EXH2
	ERV	OFF	ON/OFF	ENERGY RECOVERY VENTILATOR Output of AUX terminal; displays only if AUX = ERV
	MECH COOL ON or HEAT STAGES ON	0	0, 1, or 2	Displays stage of mechanical cooling that is active. Displays the stage of heat pump heating that is active.
	FAN SPEED	N/A	LOW or HIGH	SUPPLY FAN SPEED Displays speed setting of fan on a 2-speed fan unit.
	W (HEAT ON)	N/A	ON/OFF	HEAT DEMAND STATUS Displays status of heat demand on a 2-speed fan unit.
SETPOINTS	MAT SET	53F	38 to 65 F; increment by 1	SUPPLY AIR SETPOINT Setpoint determines where the economizer will modulate the OA damper to maintain the mixed air temperature.
	LOW T LOCK	32F	-45 to 80 F; increment by 1	COMPRESSOR LOW TEMPERATURE LOCKOUT Setpoint determines outdoor temperature when the mechanical cooling cannot be turned on. Commonly referred to as the Compressor lockout.
	DRYBLB SET	63F	48 to 80 F; increment by 1	OA DRY BULB TEMPERATURE CHANGEOVER SETPOINT Setpoint determines where the economizer will assume outdoor air temperature is good for free cooling; e.g.; at 63 F unit will economize at 62 F and below and not economize at 64 F and above. There is a 2 F deadband.
	ENTH CURVE	ES3	ES1,ES2,ES3,ES4, or ES5	ENTHALPY CHANGEOVER CURVE Enthalpy boundary "curves" for economizing using single enthalpy.
	DCV SET	1100ppm	500 to 2000ppm; increment by 100	DEMAND CONTROLLED VENTILATION Displays only if CO ₂ sensor is connected. Setpoint for Demand Controlled Ventilation of space. Above the setpoint, the OA dampers will modulate open to bring in additional OA to maintain a space ppm level below the setpoint.
	MIN POS	2.8 V	2 to 10 Vdc	VENTILATION MINIMUM POSITION Displays ONLY if a CO ₂ sensor is NOT connected.
	VENTMAX With 2-speed fan units VENTMAX L (low speed fan) and VENTMAX H (high speed fan) settings are required	2.8 V	2 to 10 Vdc	DCV MAXIMUM DAMPER POSITION Displays only if a CO ₂ sensor is connected. Used for Vb _v (ventilation max cfm) setpoint. Displays 2 to 10 V if <3 sensors (RA,OA, and MA). In AUTO mode dampers controlled by CFM.
			100 to 9990 cfm; increment by 10	If OA, MA, RA, and CO ₂ sensors are connected and DCV CAL ENABLE is set to AUTO mode, the OA dampers are controlled by CFM and displays from 100 to 9990 CFM.
			2 to 10 Vdc	With 2-speed fan units VENT L (low speed fan) and MIN POS H (high speed fan) settings are required. Default for VENTMAX L is 3.2V and VENTMAX H is 2.8V
	VENTMIN With 2-speed fan units VENTMIN L (low speed fan) and VENTMIN H (high speed fan) set	2.25 V	2 to 10 Vdc or 100 to 9990 cfm increment by 10	DCV MINIMUM DAMPER POSITION Displays only if a CO ₂ sensor is connected. Used for Ba (ventilation min cfm) setpoint. Displays 2 to 10 V if <3 sensors (RA, OA, and MA). Va is only set if DCV is used. This is the ventilation for less than maximum occupancy of the space. In AUTO mode dampers controlled by CFM.
			100 to 9990 cfm; increment by 10	If OA, MA, RA, and CO ₂ sensors are connected and DCV CAL ENABLE is set to AUTO mode, the OA dampers are controlled by CFM and displays from 100 to 9990 CFM.
2 to 10 Vdc			With 2-speed fan units VENTMIN L (low speed fan) and MIN POS H (high speed fan) settings are required. Default for VENTMIN L is 3.2V and VENTMIN H is 2.8V	
ERV OAT SP††	32°F	0 to 50 F; increment by 1	ENERGY RECOVERY VENTILATOR UNIT OUTDOOR AIR TEMPERATURE SETPOINT Only when AUX1 O = ERV	
EXH1 SET With 2-speed fan units Exh1 L (low speed fan) and Exh1 H (high speed fan) settings are required	50%	0 to 100%;increment by 1	EXHAUST FAN STAGE 1 SETPOINT Setpoint for OA damper position when exhaust fan 1 is powered by the economizer. With 2-speed fan units Exh1 L (low speed fan) and Exh1 H (high speed fan) settings are required. Default for Exh1 L is 65% and Exh1 H is 50%	
EXH2 SET With 2-speed fan units Exh2 L (low speed fan) and Exh2 H (high speed fan) settings are required	75%	0 to 100%; increment by 1	EXHAUST FAN STAGE 2 SETPOINT Setpoint for OA damper position when exhaust fan 2 is powered by the economizer. Only used when AUX1 O is set to EXH2. With 2-speed fan units Exh2 L (low speed fan) and Exh2 H (high speed fan) settings are required. Default for Exh2 L is 80% and Exh2 H is 75%	

Table 10 — Menu Structure* (cont)

MENU	PARAMETER	PARAMETER DEFAULT VALUE	PARAMETER RANGE AND INCREMENT†	NOTES
SYSTEM SETUP	INSTALL	01/01/10	N/A	Display order = MM/DD/YY Setting order = DD, MM, then YY.
	UNITS DEG	F	F or C	Sets economizer controller in degrees Fahrenheit or Celsius
	EQUIPMENT	CONV	Conventional or HP	CONV = conventional; HP O/B = Enable Heat Pump mode. Use AUX2 1 for Heat Pump input from thermostat or controller. See Menu Note 4.
	AUX2 IN	W	SD/W or HP(O)/HP(B)	In CONV mode: SD + Enables configuration of shutdown (default); W = Informs controller that system is in heating mode. NOTE: If using 2-speed fan mode, you must program CONV mode for W. Shutdown is not available in 2-speed fan mode. See Menu Note 4. In HP O/B mode: HP(O) = energize heat pump on Cool (default); HP(B) = energize heat pump on heat.
	FAN SPEED	2 speed	1 speed/2 speed	Sets the economizer controller for operation of 1 speed or 2 speed supply fan. NOTE: 2-speed fan option also needs Heat (W1) programmed in AUX 2 In. See Menu Note 4.
	FAN CFM	5000cfm	100 to 15000 cfm; increment by 100	UNIT DESIGN AIRFLOW (CFM) Enter only if using DCVAL ENA = AUTO The value is found on the nameplate label for the specific unit.
	AUX1 OUT	NONE	NONE ERV EXH2 SYS	Select OUTPUT for AUX1 O relay • NONE = not configured (output is not used) • ERV = Energy Recovery Ventilator†† • EXH2 = second damper position relay closure for second exhaust fan • SYS = use output as an alarm signal
	OCC	INPUT	INPUT or ALWAYS	OCCUPIED MODE BY EXTERNAL SIGNAL When using a setback thermostat with occupancy out (24 vac), the 24 vac is input "INPUT" to the OCC terminal. If no occupancy output from the thermostat then change program to "ALWAYS" OR add a jumper from terminal R to OCC terminal.
	FACTORY DEFAULT	NO	NO or YES	Resets all set points to factory defaults when set to YES. LCD will briefly flash YES and change to NO but all parameters will change to the factory default values. NOTE: RECHECK AUX2 IN and FANTYPE for required 2-speed values.
	ADVANCED SETUP	MA LO SET	45°F	35 to 55 F; Incremented by 10
FREEZE POS		CLO	CLO or MIN	FREEZE PROTECTION DAMPER POSITION Damper position when freeze protection is active (closed or MIN POS).
CO2 ZERO		0ppm	0 to 500 ppm; Increment by 10	CO ₂ ppm level to match CO ₂ sensor start level.
CO2 SPAN		2000ppm	1000 to 3000 ppm; Increment by 10	CO ₂ ppm span to match CO ₂ sensor.
STG3 DLY		2.0h	0 min, 5 min, 15 min, then 15 min intervals. Up to 4 hrs or OFF	COOLING STAGE 3 DELAY Delay after stage 2 cool has been active. Turns on second stage of cooling when economizer is first stage and mechanical cooling is second stage. Allows three stages of cooling, 1 economizer and 2 mechanical. OFF = no Stage 3 cooling
SD DMPR POS		CLO	CLO or OPN	Indicates shutdown signal from space thermostat or unitary controller. When controller receives 24 Vac input on the SD terminal in conventional mode, the OA damper will open if programmed for OPN and OA damper will close if programmed for CLO. All other controls, e.g., fans, etc. will shut off.
DA LO ALM		45 F (7 C)	35 to 65 F; (2 to 18 C) Incremented by 5 deg.	Used for alarm for when the DA air temperature is too low. Set lower range of alarm, below this temperature the alarm will show on the display.
DA HI ALM		80 F (27 C)	70 to 180 F; (21 to 82 C) Incremented by 5 deg.	Used for alarm for when the DA air temperature is too high. Set upper range of alarm, above this temperature the alarm will show on the display.
DCVCAL ENA		MAN	MAN (manual) AUTO	Turns on the DCV automatic control of the dampers. Resets ventilation based on the RA, OA, and MA sensor conditions. Requires all 3 RA, OA, and MA sensors.

Table 10 — Menu Structure* (cont)

MENU	PARAMETER	PARAMETER DEFAULT VALUE	PARAMETER RANGE AND INCREMENT†	NOTES
ADVANCED SETUP (CONT)	MAT T CAL	0.0°F	±2.5 F	SUPPLY AIR TEMPERATURE CALIBRATION Allows for the operator to adjust for an out of calibration temperature sensor.
	OAS T CAL	0.0°F	±2.5 F	OUTSIDE AIR TEMPERATURE CALIBRATION Allows for the operator to adjust for an out of calibration temperature sensor.
	OA H CAL	0% RH	±10% RH	OUTSIDE AIR HUMIDITY CALIBRATION Allows for operator to adjust for an out of calibration humidity sensor.
	RA T CAL	0.0°F	±2.5 F	RETURN AIR TEMPERATURE CALIBRATION Allows for the operator to adjust for an out of calibration temperature sensor.
	RA H CAL	0% RH	±10% RH	RETURN AIR HUMIDITY CALIBRATION Allows for operator to adjust for an out of calibration humidity sensor.
	DA T CAL	0.0°F	±2.5 F	DISCHARGE AIR TEMPERATURE CALIBRATION Allows for the operator to adjust for an out of calibration temperature sensor.
	2SP FAN DELAY	5 Minutes	0 to 20 minutes in 1 minute increments	TIME DELAY ON SECOND STAGE ECONOMIZING When in economizing mode this is the delay for the high speed fan to try to satisfy the call for second stage cooling before the first stage mechanical cooling is enabled.
CHECKOUT	DAMPER MINIMUM POSITION	N/A	N/A	The checkout for the damper minimum position is based on the system.
	DAMPER OPEN	N/A	N/A	Position damper to the full open position. Exhaust fan contacts enable during the DAMPER OPEN test. Make sure you pause in the mode to allow exhaust contacts to energize due to the delay in the system.
	DAMPER CLOSE	N/A	N/A	Positions damper to the fully closed position
	CONNECT Y1-O	N/A	N/A	Closes the Y1-O relay (Y1-O)
	CONNECT Y2-O	N/A	N/A	Closes the Y2-O relay (Y2-O)
	CONNECT AUX1-O	N/A	N/A	Energizes the AUX output. If Aux setting is: • NONE — not action taken • ERV — 24 Vac out. Turns on or signals an ERV that the conditions are not good for economizing but are for ERV operation.†† • SYS — 24 Vac out. Issues a system alarm
	CONNECT EXH1	N/A	N/A	Closes the power exhaust fan 2 relay (EXH1)
ALARMS	Alarms display only when they are active. The menu title "ALARMS(#)" includes the number of active alarms in parenthesis (). When using SYLK bus sensors, "SYLK" will appear on the screen, and when using 20k OA temperature sensors, "SENS T" will appear on the screen			
	MA T SENS ERR	N/A	N/A	SUPPLY AIR TEMPERATURE SENSOR ERROR Mixed air sensor has failed or become disconnected - check wiring then replace sensor if the alarm continues.
	CO2 SENS ERR	N/A	N/A	CO ₂ SENSOR ERROR CO ₂ sensor has failed, gone out of range or become disconnected - check wiring then replace sensor if the alarm continues.
	OA SYLK T ERR	N/A	N/A	OUTSIDE AIR S-BUS SENSOR ERROR Outdoor air enthalpy sensor has failed or become disconnected - check wiring then replace sensor if the alarm continues.
	OA SYLK H ERR	N/A	N/A	
	RA SYLK T ERR	N/A	N/A	RETURN AIR S-BUS SENSOR ERROR Return air enthalpy sensor has failed or become disconnected - check wiring then replace sensor if the alarm continues.
	RA SYLK H ERR	N/A	N/A	
	DA SYLK T ERR	N/A	N/A	DISCHARGE AIR S-BUS SENSOR ERROR Discharge air sensor has failed or become disconnected - check wiring then replace sensor if the alarm continues.
	OA SENS T ERR	N/A	N/A	OUTSIDE AIR TEMPERATURE SENSOR ERROR Outdoor air temperature sensor has failed or become disconnected - check wiring then replace if the alarm continues.
	ACT ERROR	N/A	N/A	ACTUATOR ERROR Actuator has failed or become disconnected - check for stall, over voltage, under voltage and actuator count. Replace actuator if damper is movable and supply voltage is between 21.6 V and 26.4 V. Check actuator count on STATUS menu.
FREEZE ALARM	N/A	N/A	Check if outdoor temperature is below the LOW Temp Lockout on setpoint menu. Check if Mixed air temperature on STATUS menu is below the Lo Setpoint on Advanced menu. When conditions are back in normal range then the alarm will go away.	

Table 10 — Menu Structure* (cont)

MENU	PARAMETER	PARAMETER DEFAULT VALUE	PARAMETER RANGE AND INCREMENT†	NOTES
ALARMS (CONT)	SHUTDOWN ACTIVE	N/A	N/A	AUX2 IN is programmed for SHUTDOWN and 24 V has been applied to AUX2 IN terminal.
	DMP CAL RUNNING	N/A	N/A	DAMPER CALIBRATION ROUTINE RUNNING If DCV Auto enable has been programmed, when the W7220 is completing a calibration on the dampers, this alarm will display. Wait until the calibration is completed and the alarm will go away. Must have OA, MA and RA sensors for DCV calibration; set up in the Advanced setup menu.
	DA SENS ALM	N/A	N/A	DISCHARGE AIR TEMPERATURE SENSOR ALARM Discharge air temperature is out of the range set in the ADVANCED SETUP Menu. Check the temperature of the discharge air.
	SYS ALARM	N/A	N/A	When AUX1-0 is set to SYS and there is any alarm (e.g., failed sensors, etc.), the AUX1-0 terminal has 24 Vac out.
	ACT UNDER V	N/A	N/A	ACTUATOR VOLTAGE LOW Voltage received by actuator is above expected range.
	ACT OVER V	N/A	N/A	ACTUATOR VOLTAGE HIGH Voltage received by actuator is below expected range.
	ACT STALLED	N/A	N/A	ACTUATOR STALLED Actuator stopped before achieving commanded position.

LEGEND

- CLO** — Compressor Lockout
- ERV** — Energy Recovery Ventilator
- LCD** — Liquid Crystal Display
- MA** — Mixed Air
- MAT** — Mixed Air Temperature
- N/A** — Not Applicable
- OA** — Outdoor Air
- OAT** — Outdoor Air Temperature
- OCC** — Occupied
- RA** — Return Air
- RAT** — Return Air Temperature
- RTU** — Rooftop Unit
- SYS** — System

NOTES:

1. STATUS → OCCUPIED — The factory-standard Occupancy signal originates with a thermostat or other controller call for indoor fan operation at CTB terminal G. This signal passes through the Central Terminal Board's OCCUPIED jumper JMP1 to the ECONO connector and to the W7220's OCC input terminal. An external timeclock or relay is required to implement an Occupancy schedule on the economizer damper position.
2. STATUS → MA TEMP, SETPOINTS → MAT SET — The W7220 menu parameters and labels include designations MA, MAT and Mixed Air for the economizer cooling control sensor. On these rooftop units, the economizer control sensor is located downstream of the evaporator/indoor coil in the supply fan section where this sensor is designated as Supply Air Temperature (SAT) sensor.
3. SETPOINTS → DRYBLB SET — This point is not displayed if a Return Air (differential) temperature sensor or an Outdoor Air enthalpy sensor is connected.
4. SYSTEM SETUP parameters must be configured as noted for 2-Speed unit operation:
EQUIPMENT = CONV
AUX2 I = W
FAN SPEED = 2SPEED

* Table 10 illustrates the complete hierarchy. Your menu parameters may be different depending on your configuration. For example if you do not have a DCV (CO₂) sensor, then none of the DCV parameters appear.

† When values are displayed, pressing and holding the ▲ or ▼ button causes the display to automatically increment.

** N/A = Not Applicable.

†† ERV Operation: When in cooling mode AND the conditions are NOT OK for economizing - the ERV terminal will be energized. In the Heating mode, the ERV terminal will be energized when the OA is below the ERV OAT setpoint in the setpoint menu.

For damper minimum position settings and checkout menu readings, see Table 11. See Tables 12-19 for dry bulb and enthalpy sequence of operation.

Table 11 — Damper Minimum Position Settings and Readings on Checkout Menu

FAN SPEED	DEMAND CONTROLLED VENTILATION (CO ₂ SENSOR)	SETPOINTS	CHECKOUT
1	NO	MIN POS	VMAX – HS
1	NO	N/A	N/A
2	NO	MIN POS H	VMAX – HS
2	NO	MIN POS L	VMAX – LS
1	YES	VENT MIN	VMIN – HS
1	YES	VENT MAX	VMAX – HS
2	YES	VENT MIN H	VMIN – HS
2	YES	VENT MAX H	VMAX – LS
2	YES	VENT MIN L	N/A
2	YES	VENT MAX L	N/A

Table 12 — Dry Bulb Operation, No Demand Controlled Ventilation (DCV) (CO₂ Sensor) — 1 Speed Fan

DCV	OUTSIDE AIR GOOD TO ECONOMIZE?	Y1-I	Y2-I	FAN SPEED	Y1-O	Y2-O	OCCUPIED	UNOCCUPIED
None	No	Off	Off	High	0-v/Off	0-v/Off	MIN POS	Closed
		On	Off	High	24-v/On	0-v/Off	MIN POS	Closed
		On	On	High	24-v/On	24-v/On	MIN POS	Closed
	Yes	Off	Off	High	0-v/Off	0-v/Off	MIN POS	Closed
		On	Off	High	0-v/Off	0-v/Off	MIN POS to Full-Open	Closed to Full-Open
		On	On	High	24-v/On	24-v/Off*	MIN POS to Full-Open	Closed to Full-Open

*With stage 3 delay (STG3 DLY) in Advanced setup menu, second stage of mechanical cooling Y2-O can be turned on after the delay if the calls for Y1-I and Y2-I have not been satisfied.

Table 13 — Dry Bulb Operation, with Demand Controlled Ventilation (DCV) (CO₂ Sensor) — 1 Speed Fan

DCV	OUTSIDE AIR GOOD TO ECONOMIZE?	Y1-I	Y2-I	FAN SPEED	Y1-O	Y2-O	OCCUPIED	UNOCCUPIED
Below CO ₂ Set	No	Off	Off	High	0-v/Off	0-v/Off	VENTMIN	Closed
		On	Off	High	24-v/On	0-v/Off	VENTMIN	Closed
		On	On	High	24-v/On	24-v/On	VENTMIN	Closed
	Yes	Off	Off	High	0-v/Off	0-v/Off	VENTMIN	Closed
		On	Off	High	0-v/Off	0-v/Off	VENTMIN to Full-Open	Closed to Full-Open
		On	On	High	24-v/On	0-v/Off*	VENTMIN to Full-Open	Closed to Full-Open
Above CO ₂ Set	No	Off	Off	High	0-v/Off	0-v/Off	VENTMIN to VENTMAX	Closed
		On	Off	High	24-v/On	0-v/Off	VENTMIN to VENTMAX	Closed
		On	On	High	24-v/On	24-v/On	VENTMIN to VENTMAX	Closed
	Yes	Off	Off	High	0-v/Off	0-v/Off	VENTMIN to VENTMAX	Closed
		On	Off	High	0-v/Off	0-v/Off	VENTMIN to Full-Open	Closed to Full-Open
		On	On	High	24-v/On	0-v/Off*	VENTMIN to Full-Open	Closed to Full-Open

*With stage 3 delay (STG3 DLY) in Advanced setup menu, second stage of mechanical cooling Y2-O can be turned on after the delay if the calls for Y1-I and Y2-I have not been satisfied.

Table 14 — Enthalpy Operation, No Demand Controlled Ventilation (DCV) (CO₂ Sensor) — 1 Speed Fan

DCV	OUTSIDE AIR GOOD TO ECONOMIZE?	Y1-I	Y2-I	FAN SPEED	Y1-O	Y2-O	OCCUPIED	UNOCCUPIED
None	No	Off	Off	High	0-v/Off	0-v/Off	MIN POS	Closed
		On	Off	High	24-v/On	0-v/Off	MIN POS	Closed
		On	On	High	24-v/On	24-v/On	MIN POS	Closed
	Yes	Off	Off	High	0-v/Off	0-v/Off	MIN POS	Closed
		On	Off	High	0-v/Off	0-v/Off	MIN POS to Full-Open	Closed to Full-Open
		On	On	High	24-v/On	0-v/Off*	MIN POS to Full-Open	Closed to Full-Open

*With stage 3 delay (STG3 DLY) in Advanced setup menu, second stage of mechanical cooling Y2-O can be turned on after the delay if the calls for Y1-I and Y2-I have not been satisfied.

Table 15 — Enthalpy Operation, with Demand Controlled Ventilation (DCV) (CO₂ Sensor) — 1 Speed Fan

DCV	OUTSIDE AIR GOOD TO ECONOMIZE?	Y1-I	Y2-I	FAN SPEED	Y1-O	Y2-O	OCCUPIED	UNOCCUPIED
Below Set	No	Off	Off	High	0-v/Off	0-v/Off	VENTMIN	Closed
		On	Off	High	24-v/On	0-v/Off	VENTMIN	Closed
		On	On	High	24-v/On	24-v/On	VENTMIN	Closed
	Yes	Off	Off	High	0-v/Off	0-v/Off	VENTMIN	Closed
		On	Off	High	0-v/Off	0-v/Off	VENTMIN to Full-Open	Closed to Full-Open
		On	On	High	24-v/On	0-v/Off†	VENTMIN to Full-Open	Closed to Full-Open
Above Set	No	Off	Off	High	0-v/Off	0-v/Off	VENTMIN to VENTMAX	Closed
		On	Off	High	24-v/On	0-v/Off	VENTMIN L to VENTMAX	Closed
		On	On	High	24-v/On	24-v/On	VENTMIN H to VENTMAX	Closed
	Yes	Off	Off	High	0-v/Off	0-v/Off	VENTMIN L to VENTMAX	Closed
		On	Off	High	0-v/Off	0-v/Off	VENTMIN to Full-Open	Closed to Full-Open
		On	On	High	DELAY* 24-v/On	0-v/Off†	VENTMIN to Full-Open	Closed to Full-Open

*With 2SP FAN DELAY (Advanced Setup Menu) when in the economizing mode there is a delay for the high speed fan to try to satisfy the call for second stage cooling by turning on the fan to high and opening the OA damper 100% before the first stage mechanical cooling is enabled.

†With stage 3 delay (STG3 DLY) in Advanced setup menu, second stage of mechanical cooling Y2-O can be turned on after the delay if the calls for Y1-I and Y2-I have not been satisfied.

Table 16 — Dry Bulb Operation, No Demand Controlled Ventilation (DCV) (CO₂ Sensor) — 2 Speed Fan

DCV	OUTSIDE AIR GOOD TO ECONOMIZE?	Y1-I	Y2-I	FAN SPEED	Y1-O	Y2-O	OCCUPIED	UNOCCUPIED
None	No	Off	Off	Low	0-v/Off	0-v/Off	MIN POS L	Closed
		On	Off	Low	24-v/On	0-v/Off	MIN POS L	Closed
		On	On	High	24-v/On	24-v/On	MIN POS H	Closed
	Yes	Off	Off	Low	0-v/Off	0-v/Off	MIN POS L	Closed
		On	Off	Low	0-v/Off	0-v/Off	MIN POS L to Full-Open	Closed to Full-Open
		On	On	High	DELAY* 24-v/On	0-v/Off†	MIN POS H to Full-Open	Closed to Full-Open

*With 2SP FAN DELAY (Advanced Setup Menu) when in the economizing mode there is a delay for the high speed fan to try to satisfy the call for second stage cooling by turning on the fan to high and opening the OA damper 100% before the first stage mechanical cooling is enabled.

†With stage 3 delay (STG3 DLY) in Advanced setup menu, second stage of mechanical cooling Y2-O can be turned on after the delay if the calls for Y1-I and Y2-I have not been satisfied.

Table 17 — Dry Bulb Operation, with Demand Controlled Ventilation (DCV) (CO₂ Sensor) — 2 Speed Fan

DCV	OUTSIDE AIR GOOD TO ECONOMIZE?	Y1-I	Y2-I	FAN SPEED	Y1-O	Y2-O	OCCUPIED	UNOCCUPIED
Below Set	No	Off	Off	Low	0-v/Off	0-v/Off	VENTMIN L	Closed
		On	Off	Low	24-v/On	0-v/Off	VENTMIN L	Closed
		On	On	High	24-v/On	24-v/On	VENTMIN H	Closed
	Yes	Off	Off	Low	0-v/Off	0-v/Off	VENTMIN L	Closed
		On	Off	Low	0-v/Off	0-v/Off	VENTMIN L to Full-Open	Closed to Full-Open
		On	On	High	24-v/On	0-v/Off†	VENTMIN H to Full-Open	Closed to Full-Open
Above Set	No	Off	Off	Low	0-v/Off	0-v/Off	VENTMIN L to VENTMAX	Closed
		On	Off	Low	24-v/On	0-v/Off	VENTMIN L to VENTMAX	Closed
		On	On	High	24-v/On	24-v/On	VENTMIN H to VENTMAX	Closed
	Yes	Off	Off	Low	0-v/Off	0-v/Off	VENTMIN L to VENTMAX	Closed
		On	Off	Low	0-v/Off	0-v/Off	VENTMIN L to Full-Open	Closed to Full-Open
		On	On	High	DELAY* 24-v/On	0-v/Off†	VENTMIN H to Full-Open	Closed to Full-Open

*With 2SP FAN DELAY (Advanced Setup Menu) when in the economizing mode there is a delay for the high speed fan to try to satisfy the call for second stage cooling by turning on the fan to high and opening the OA damper 100% before the first stage mechanical cooling is enabled.

†With stage 3 delay (STG3 DLY) in Advanced setup menu, second stage of mechanical cooling Y2-O can be turned on after the delay if the calls for Y1-I and Y2-I have not been satisfied.

Table 18 — Enthalpy Operation, No Demand Controlled Ventilation (DCV) (CO₂ Sensor) — 2 Speed Fan

DCV	OUTSIDE AIR GOOD TO ECONOMIZE?	Y1-I	Y2-I	FAN SPEED	Y1-O	Y2-O	OCCUPIED	UNOCCUPIED
None	No	Off	Off	Low	0-v/Off	0-v/Off	MIN POS L	Closed
		On	Off	Low	24-v/On	0-v/Off	MIN POS L	Closed
		On	On	High	24-v/On	24-v/On	MIN POS H	Closed
	Yes	Off	Off	Low	0-v/Off	0-v/Off	MIN POS L	Closed
		On	Off	Low	0-v/Off	0-v/Off	MIN POS L to Full-Open	Closed to Full-Open
		On	On	High	DELAY* 24-v/On	0-v/Off†	MIN POS H to Full-Open	Closed to Full-Open

*With 2SP FAN DELAY (Advanced Setup Menu) when in the economizing mode there is a delay for the high speed fan to try to satisfy the call for second stage cooling by turning on the fan to high and opening the OA damper 100% before the first stage mechanical cooling is enabled.

†With stage 3 delay (STG3 DLY) in Advanced setup menu, second stage of mechanical cooling Y2-O can be turned on after the delay if the calls for Y1-I and Y2-I have not been satisfied.

Table 19 — Enthalpy Operation, with Demand Controlled Ventilation (DCV) (CO₂ Sensor) — 2 Speed Fan

DCV	OUTSIDE AIR GOOD TO ECONOMIZE?	Y1-I	Y2-I	FAN SPEED	Y1-O	Y2-O	OCCUPIED	UNOCCUPIED
Below Set	No	Off	Off	Low	0-v/Off	0-v/Off	VENTMIN L	Closed
		On	Off	Low	24-v/On	0-v/Off	VENTMIN L	Closed
		On	On	High	24-v/On	24-v/On	VENTMIN H	Closed
	Yes	Off	Off	Low	0-v/Off	0-v/Off	VENTMIN L	Closed
		On	Off	Low	0-v/Off	0-v/Off	VENTMIN L to Full-Open	Closed to Full-Open
		On	On	High	24-v/On	0-v/Off†	VENTMIN H to Full-Open	Closed to Full-Open
Above Set	No	Off	Off	Low	0-v/Off	0-v/Off	VENTMIN L to VENTMAX	Closed
		On	Off	Low	24-v/On	0-v/Off	VENTMIN L to VENTMAX	Closed
		On	On	High	24-v/On	24-v/On	VENTMIN H to VENTMAX	Closed
	Yes	Off	Off	Low	0-v/Off	0-v/Off	VENTMIN L to VENTMAX	Closed
		On	Off	Low	0-v/Off	0-v/Off	VENTMIN L to Full-Open	Closed to Full-Open
		On	On	High	DELAY* 24-v/On	0-v/Off†	VENTMIN H to Full-Open	Closed to Full-Open

*With 2SP FAN DELAY (Advanced Setup Menu) when in the economizing mode there is a delay for the high speed fan to try to satisfy the call for second stage cooling by turning on the fan to high and opening the OA damper 100% before the first stage mechanical cooling is enabled.

†With stage 3 delay (STG3 DLY) in Advanced setup menu, second stage of mechanical cooling Y2-O can be turned on after the delay if the calls for Y1-I and Y2-I have not been satisfied.

Table 20 — Single Enthalpy and Dual Enthalpy High Limit Curves

ENTHALPY CURVE	TEMP. DRY BULB (F)	TEMP. DEWPOINT (F)	ENTHALPY (btu/lb/da)	POINT P1		POINT P2	
				TEMP. (F)	HUMIDITY (%RH)	TEMP. (F)	HUMIDITY (%RH)
ES1	80	60	28.0	80	36.8	66.3	80.1
ES2	75	57	26.0	75	39.6	63.3	80.0
ES3	70	54	24.0	70	42.3	59.7	81.4
ES4	65	51	22.0	65	44.8	55.7	84.2
ES5	60	48	20.0	60	46.9	51.3	88.5
HL	86	66	32.4	86	38.9	72.4	80.3

Enthalpy Settings

When the OA temperature, enthalpy and dew point are below the respective setpoints, the Outdoor Air can be used for economizing. Figure 50 shows the new single enthalpy boundaries in the W7220. There are 5 boundaries (setpoints ES1 through ES5), which are defined by dry bulb temperature, enthalpy and dew point.

Refer to Table 20 for ENTH CURVE setpoint values.

The W7220 calculates the enthalpy and dew point using the OA temperature and humidity input from the OA enthalpy sensor. When the OA temperature, OA humidity and OA dew point are all below the selected boundary, the economizer sets the economizing mode to YES, economizing is available.

When all of the OA conditions are above the selected boundary, the conditions are not good to economize and the mode is set to NO.

Figure 50 shows the 5 current boundaries. There is also a high limit boundary for differential enthalpy. The high limit boundary is ES1 when there are no stages of mechanical cooling energized and HL (high limit) when a compressor stage is energized.

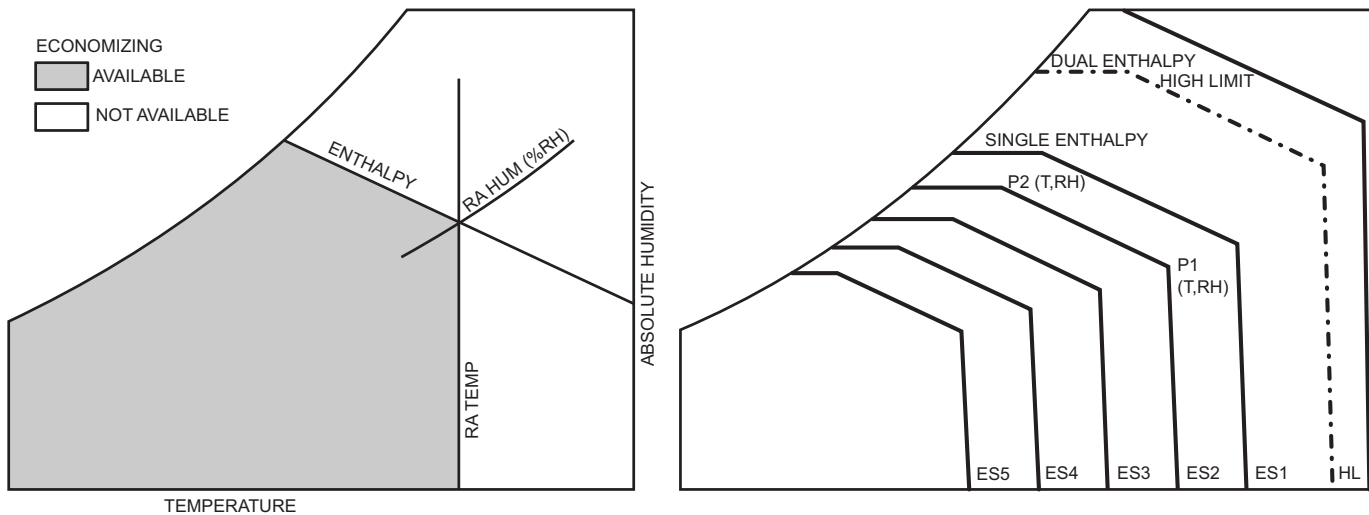

Fig. 50 — Single Enthalpy Curve Boundaries

Checkout

Inspect all wiring connections at the economizer module's terminals, and verify compliance with the installation wiring diagrams. For checkout, review the Status of each configured parameter and perform the Checkout tests.

NOTE: For information about menu navigation and use of the keypad see Interface Overview on page 34.

⚠ WARNING

Failure to follow this warning could result in personal injury, property damage, or death.

Before performing service or maintenance operations on unit, always turn off main power switch to unit and install lock(s) and lockout tag(s). Unit may have more than one power switch. Ensure electrical service to rooftop unit agrees with voltage and amperage listed on the unit rating plate.

If any wiring changes are required, first be sure to remove power from the Economizer module before starting work. Pay particular attention to verifying the power connection (24 Vac).

Power Up

After the W7220 module is mounted and wired, apply power.

Initial Menu Display

On initial start up, Honeywell displays on the first line and economizer W7220 on the second line. After a brief pause, the revision of the software appears on the first line and the second line is blank.

Power Loss (Outage or Brownout)

All setpoints and advanced settings are restored after any power loss or interruption.

NOTE: All settings are stored in non-volatile flash memory.

Status

Use the Status menu (see Table 10) to check the parameter values for the various devices and sensors configured.

NOTE: For information about menu navigation and use of the keypad see Interface Overview on page 34.

Checkout Tests

Use the Checkout menu (see page 39) to test the damper operation and any configured outputs. Only items that are configured are shown in the Checkout menu.

NOTE: For information about menu navigation and use of the keypad see Interface Overview on page 34.

To perform a Checkout test:

1. Scroll to the desired test in the Checkout menu using the ▲ and ▼ buttons.
2. Press the ↵ (Enter) button to select the item. RUN? appears.
3. Press the ↵ (Enter) button to start the test. The unit pauses and then displays IN PROGRESS. When the test is complete, DONE appears.
4. When all desired parameters have been tested, press the ⏹ (Menu Up/Exit) button to end the test.

The Checkout tests can all be performed at the time of installation or at any time during the operation of the system as a test that the system is operable.

⚠ CAUTION

Failure to follow this caution may result in damage to equipment. Be sure to allow enough time for compressor startup and shutdown between checkout tests so that you do not short-cycle the compressors.

Troubleshooting

Alarms

The economizer module provides alarm messages that display on the 2-line LCD.

NOTE: Upon power up, the module waits 60 minutes before checking for alarms. This allows time for all the configured devices (e.g. sensors, actuator) to become operational. The exception is the SAT sensor which will alarm immediately.

If one or more alarms are present and there has been no keypad activity for at least 5 minutes, the Alarms menu displays and cycles through the active alarms.

You can also navigate to the Alarms menu at any time.

Clearing Alarms

Once the alarm has been identified and the cause has been removed (e.g. replaced faulty sensor) the alarm can be cleared from the display.

To clear an alarm, perform the following:

1. Navigate to the desired alarm.
2. Press the ↵ (Enter) button. ERASE? displays.
3. Press the ↵ (Enter) button. ALARM ERASED displays.

4. Press the ⏮ (Menu Up/Exit) button to complete the action and return to the previous menu.

NOTE: If the alarm still exists after clearing it, it is redisplayed within 5 seconds.

SMOKE DETECTORS

Smoke detectors are available as factory-installed options on 50HCQ models. Smoke detectors may be specified for Supply Air only or for Return Air without or with economizer, or in combination of Supply Air and Return Air. Return Air smoke detectors are arranged for vertical return configurations only. All components necessary for operation are factory-provided and mounted. The unit is factory-configured for immediate smoke detector shutdown operation; additional wiring or modifications to unit terminal board may be necessary to complete the unit and smoke detector configuration to meet project requirements.

Units equipped with factory-optional Return Air smoke detectors require a relocation of the sensor module at unit installation. See Fig. 51 for the as-shipped location.

Completing Return Air Smoke Sensor Installation

1. Unscrew the two screws holding the Return Air Smoke Detector assembly. See Fig. 52, Step 1. Save the screws.
2. Turn the assembly 90 degrees and then rotate end to end. Make sure that the elbow fitting is pointing down. See Fig. 52, Step 2.
3. Screw the sensor and detector plate into its operating position using screws from Step 1. See Fig. 52, Step 3.
4. Connect the flexible tube on the sampling inlet to the sampling tube on the basepan.

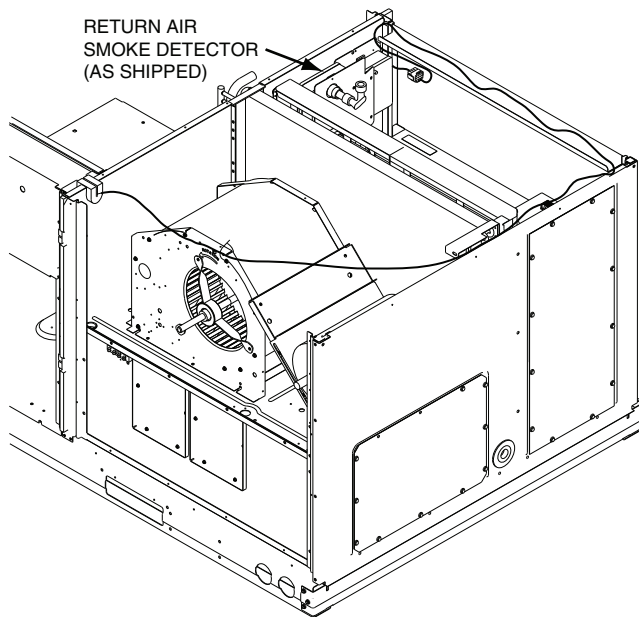

Fig. 51 — Return Air Smoke Detector, Shipping Position

Additional Application Data

Refer to the application data document “Factory Installed Smoke Detectors for Small and Medium Rooftop Units 2 to 25 Tons” for discussions on additional control features of these smoke detectors including multiple unit coordination.

RTU OPEN CONTROLLER (FACTORY OPTION)

For details on operating 50HCQ units equipped with the factory-installed RTU Open controller option, refer to the Factory-Installed Option RTU Open Multi-Protocol Controller Controls, Start-Up, Operation and Troubleshooting manual.

CONTROLLER OPTIONS

Low Ambient

If the unit comes with Electro-Mechanical (EM) control, then no adjustment is necessary.

If the unit comes with the RTU Open control option, then refer to its installation control manual for details on adjusting “Cooling Lock-Out” setting and configure for the specific job requirements.

Step 12 — Adjust Factory-Installed Options

SMOKE DETECTORS

Smoke detector(s) will be connected at the Controls Connections Board, at terminals marked “Smoke Shutdown.” Cut jumper JMP 3 when ready to energize unit.

ECONOMIZER IV OCCUPANCY SWITCH

See Fig. 53 for general EconoMiSer IV wiring. External occupancy control is managed through a connection on the Controls Connections Board.

If external occupancy control is desired, connect a time clock or remotely controlled switch (closed for Occupied, open for Unoccupied sequence) at terminals marked OCCUPANCY. Cut jumper JMP 2 to complete the installation.

Step 13 — Install Accessories

Available accessories include:

- Roof curb
- Thru-base connection kit (must be installed before unit is set on curb)
- Electric heaters and single-point connection kits
- Manual outside air damper
- Two-position motorized outside air damper
- EconoMiSer® IV (with control)
- EconoMiSer2 (without control/for external signal)
- Power Exhaust
- Differential dry-bulb sensor (EconoMiSer IV)
- Outdoor enthalpy sensor
- Differential enthalpy sensor
- CO₂ sensor
- Smoke Detector (Return Air and/or Supply Air)
- Louvered hail guard
- Motormaster® head pressure controls
- Phase monitor control

Refer to separate installation instructions for information on installing these accessories.

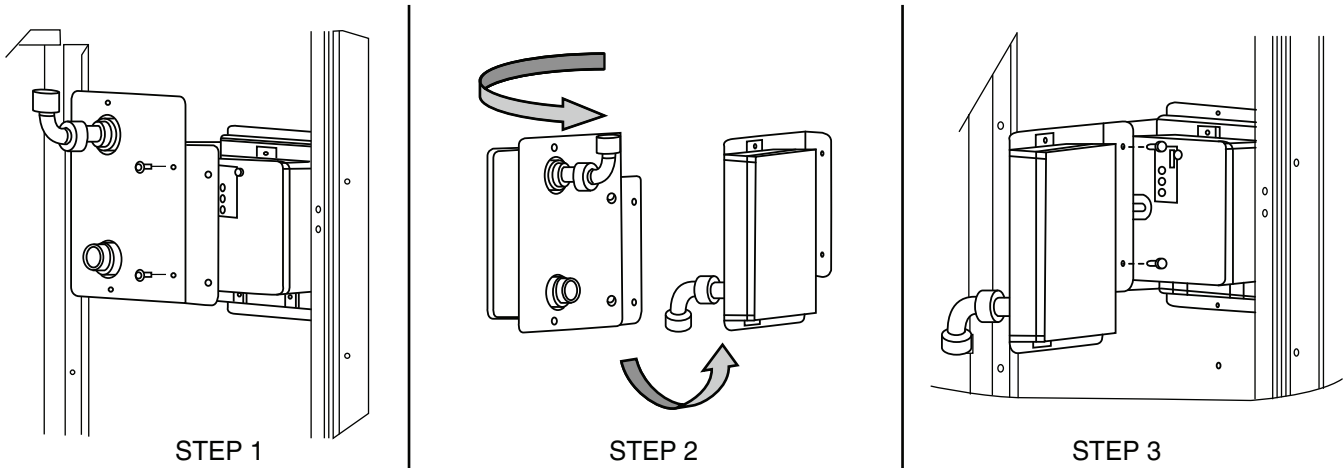

Fig. 52 — Completing Installation of Return Air Smoke Sensor

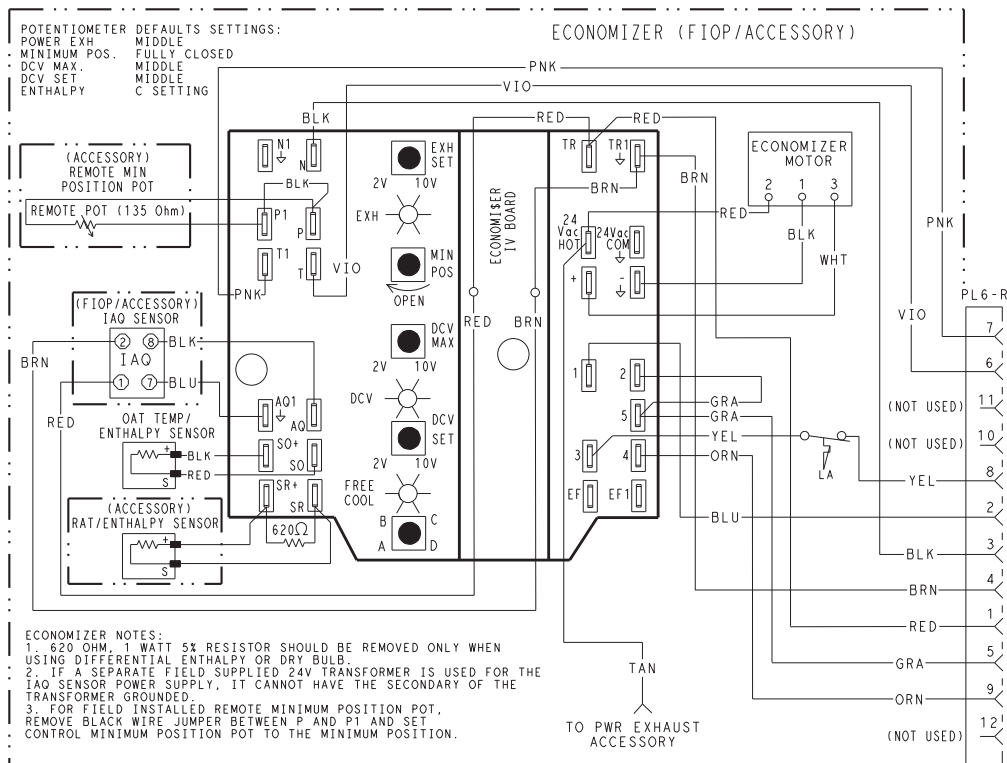

Fig. 53 — EconoMiSer IV Wiring

Step 14 — Check Belt Tension

Measure the belt span length as shown in Fig. 54. Calculate the required deflection by multiplying the belt span length by $\frac{1}{64}$. For example, if the belt span length is 32 inches: $32 \times \frac{1}{64} = \frac{1}{2}$ inch deflection.

BELT FORCE — DEFLECTION METHOD

Check the belt tension with a spring-force belt force deflection gauge (available from drive belt manufacturer).

1. Place a straightedge along the belt between the two pulleys. Measure the distance between the motor shaft and the blower shaft.
2. Set the tension gauge to the desired tension (see Table 1 in Fig. 54). Place the large O-ring at that point.
3. Press the tension checker downward on the belt until the large O-ring is at the bottom of the straightedge.
4. Adjust the belt tension as needed.

Adjust belt tension by loosening the motor mounting plate front bolts and rear bolt (see Fig. 55) and slide the plate towards the fan (to reduce tension) or away from the fan (to increase tension). Ensure the blower shaft and motor shaft are parallel to each other (pulleys aligned). Tighten all bolts securely when finished.

BELT TENSION METHOD

Requires belt tension gauge that measures tension in belt in units of lbs force.

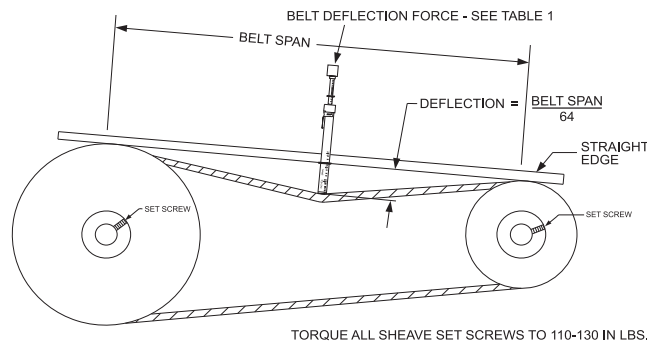

BELT CROSS SECTION	SMALLEST SHEAVE DIAMETER	BELT DEFLECTION FORCE (LBS)			
		UNNOTCHED BELTS		NOTCHED BELTS	
		USED	NEW	USED	NEW
A, AX	3.0-3.6	3.7	5.5	4.1	6.1
	3.8-4.8	4.5	6.8	5.0	7.4
	5.0-7.0	5.4	8.0	5.7	8.4
B, BX	3.4-4.2	—	—	4.9	7.2
	4.4-5.6	5.3	7.9	7.1	10.5
	5.8-8.6	6.3	9.4	8.5	12.6

Table 1

BELT CONDITION	TENSION FORCE IN BELT (LBS)
New	100
Used	80

Table 2

Fig. 54 — V-Belt Force Label

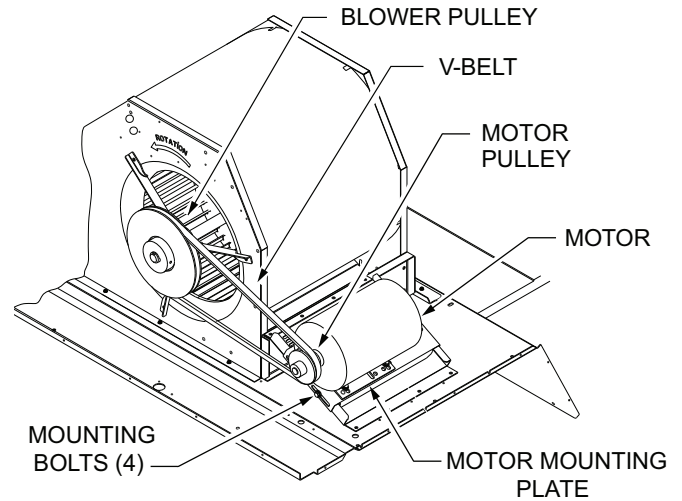

Fig. 55 — Belt Drive Motor Mounting

Pre-Start and Start-Up

This completes the mechanical installation of the unit. Refer to the unit's Service Manual for detailed Pre-Start and Start-Up instructions. Download the latest versions from HVAC Partners (www.hvacpartners.com).

Typical Unit Piping

Each heat pump refrigeration system includes a compressor, accumulator, reversing valve, dual-function outdoor coil with vapor header check valve, cooling liquid line with a filter drier and a check valve, dual-function indoor coil with a vapor header check valve, and heating liquid line with a check valve and a strainer. See Fig. 56 and Tables 21-23 for typical unit piping schematic. Dual-function outdoor and indoor coils are designed to provide parallel coil circuits during evaporator-function operation and converging coil circuits during the condenser-function operation.

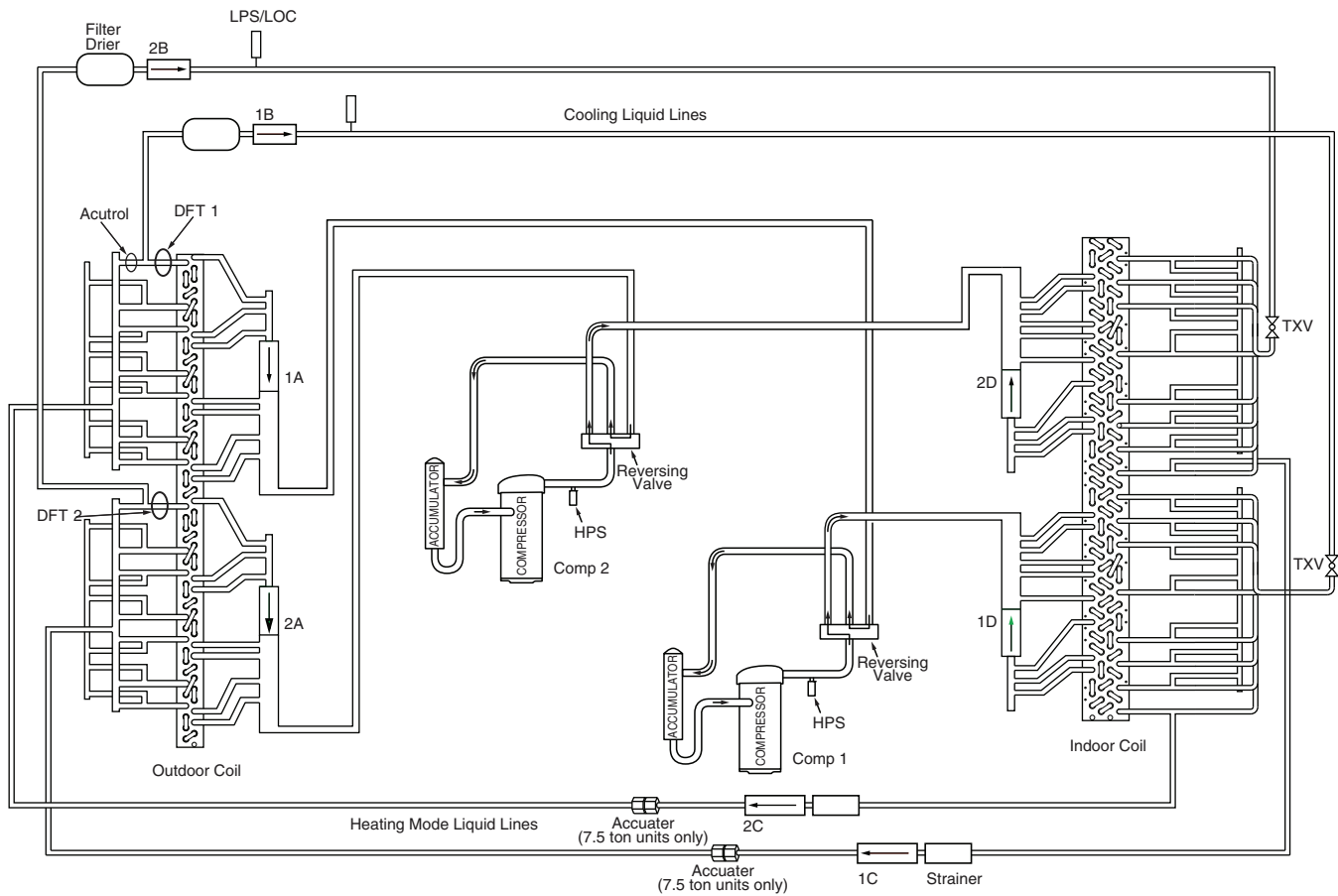

Fig. 56 — Typical Unit Piping Schematic (50HCQ08, 09 Shown)

Table 21 — Cooling Mode (each circuit)

COMPONENT	STATUS/POSITION
Reversing Valve	Energized
Check Valve A	Closed
Check Valve B	Open
Check Valve C	Closed
Check Valve D	Open

Table 22 — Heating Mode (each circuit)

COMPONENT	STATUS/POSITION
Reversing Valve	De-energized
Check Valve A	Open
Check Valve B	Closed
Check Valve C	Open
Check Valve D	Closed

Table 23 — Defrost Mode

COMPONENT	STATUS/POSITION
Defrost Thermostat	Closed
Outdoor Fan(s)	Off
Reversing Valve	Energized
Check Valve A	Closed
Check Valve B	Open
Check Valve C	Closed
Check Valve D	Open

**START-UP CHECKLIST FOR 50HCQ07-09 SINGLE PACKAGE ROOFTOP
HEAT PUMP
(REMOVE AND USE FOR JOB FILE)**

NOTE: To avoid injury to personnel and damage to equipment or property when completing the procedures listed in this start-up checklist, use good judgment, follow safe practices, and adhere to the safety considerations/information as outlined in preceding sections of this Installation Instruction document.

I. PRELIMINARY INFORMATION

MODEL NO. _____
 JOB NAME _____
 SERIAL NO. _____
 ADDRESS _____
 START-UP DATE _____
 TECHNICIAN NAME _____
 ADDITIONAL ACCESSORIES _____

II. PRE-START-UP

Verify that all packaging materials have been removed from unit (Y/N) _____
 Verify installation of outdoor air hood (Y/N) _____
 Verify that condensate connection is installed per instructions (Y/N) _____
 Verify that all electrical connections and terminals are tight (Y/N) _____
 Check that indoor-air filters are clean and in place (Y/N) _____
 Check that outdoor air inlet screens are in place (Y/N) _____
 Verify that unit is level (Y/N) _____
 Check fan wheels and propeller for location in housing/orifice and verify setscrew is tight (Y/N) _____
 Verify that fan sheaves are aligned and belts are properly tensioned (Y/N) _____
 Verify that scroll compressors are rotating in the correct direction (Y/N) _____
 Verify installation of thermostat (Y/N) _____

III. START-UP

ELECTRICAL

Supply Voltage	L1-L2 _____	L2-L3 _____	L3-L1 _____
Compressor Amps 1	L1 _____	L2 _____	L3 _____
Compressor Amps 2	L1 _____	L2 _____	L3 _____
Supply Fan Amps	L1 _____	L2 _____	L3 _____

TEMPERATURES

Outdoor-air Temperature _____ °F DB (Dry Bulb)
 Return-air Temperature _____ °F DB _____ °F Wb (Wet Bulb)
 Cooling Supply Air Temperature _____ °F

PRESSURES

Refrigerant Suction CIRCUI T A _____ PSIG
CIRCUI T B _____ PSIG
Refrigerant Discharge CIRCUI T A _____ PSIG
CIRCUI T B _____ PSIG
Verify Refrigerant Charge using Charging Charts (Y/N) _____

GENERAL

Economizer minimum vent and changeover settings to job requirements (if equipped) (Y/N) _____
Verify smoke detector unit shutdown by utilizing magnet test (Y/N) _____

IV. PREMIERLINK™ START-UP

STEPS

- 1. Check CTB for jumper 5, 6, 7 (Jumper 5, 6, 7 must be cut and open) (Y/N) _____
- 2. Open humidistat contacts (Y/N) _____
- 3. Start unit In cooling (Close Y1) (Y/N) _____

OBSERVE AND RECORD

- A. Suction pressure _____ PSIG
 - B. Discharge pressure _____ PSIG
 - C. Entering air temperature _____ ° F
 - D. Liquid line temperature at outlet or reheat coil _____ ° F
 - E. Confirm correct rotation for compressor (Y/N) _____
 - F. Check for correct ramp-up of outdoor fan motor as condenser coil warms (Y/N) _____
4. Check unit charge per charging chart (Y/N) _____
5. Switch unit to high-latent mode (sub-cooler) by closing humidistat with Y1 closed (Y/N) _____

OBSERVE

- A. Reduction in suction pressure (5 to 7 psi expected) (Y/N) _____
 - B. Discharge pressure unchanged (Y/N) _____
 - C. Liquid temperature drops to 50 to 55 F range (Y/N) _____
 - D. LSV solenoid energized (valve closes) (Y/N) _____
6. Switch unit to dehumid (reheat) by opening Y1 (Y/N) _____

OBSERVE

- A. Suction pressure increases to normal cooling level
 - B. Discharge pressure decreases (35 to 50 psi)
 - C. Liquid temperature returns to normal cooling level
 - D. LSV solenoid energized (valve closes)
 - E. DSV solenoid energized, valve opens
7. With unit in dehumid mode close W1 compressor and outdoor fan stop; LSV and DSV solenoids de-energized (Y/N) _____
8. Open W1 restore unit to dehumid mode (Y/N) _____
9. Open humidistat input compressor and outdoor fan stop; LSV and DSV solenoids de-energized (Y/N) _____
10. Restore set-points for thermostat and humidistat (Y/N) _____

CUT ALONG DOTTED LINE

CUT ALONG DOTTED LINE