



Turn to the experts

Product Data

WeatherMaster® High Efficiency Single Packaged Heat Pump Rooftop

3 to 5 Nominal Tons

ecoblue™  technology



50GCQ 04, 05, 06

High Efficiency Single Packaged Heat Pump with
Puron® Refrigerant (R-410A) and Optional Electric Heat

The New Carrier WeatherMaster® heat pump rooftop units (RTU) with EcoBlue™ Technology were designed by customers for customers and integrate new technology to provide value added benefits never seen in this type of equipment before.

New major design features include:

- Patented, industry’s first efficient indoor fan system using Vane Axial Fan technology – with electric commutated variable speed motor.
- Reliable two stage scroll compressor on all sizes.
- Upgraded unit control board with intuitive indoor fan adjustment.
- Reliable copper tube/aluminum fin condenser coil with 5/16-in. tubing to help reduce refrigerant charge verses prior designs.
- New outdoor fan system with rugged – lightweight high impact composite fan blade

50GCQ WeatherMaster® units up to 5 tons are specifically designed to fit on Carrier roof curbs that were installed back to 1989, which makes replacement easy and eliminates the need for curb adapters or changing utility connections.

Two stage cooling capacity control delivers SEERs up to 16.2 while heating HSPF is as high as 8.3. All models are capable of either vertical or horizontal airflow.

The Carrier rooftop unit (RTU) was designed by customers for customers. With “no-strip” screw collars, handled access panels, and more, the unit is easy to install, easy to maintain, and easy to use. Your new 3 to 5 ton WeatherMaster Carrier rooftop unit (RTU) provides optimum comfort and control from a packaged rooftop.

Value-added features include:

- precisely sized Suction Line Accumulator to help insure reliable operation at unit operation conditions
- Puron® refrigerant (R-410A)
- single point electrical connections
- optional fully integrated SystemVu™ controls
- RTU Open controller for BACnet¹, LonWorks², Modbus³ and Johnson Controls N2
- optional fully insulated cabinet with optional foil faced insulation
- TXV refrigerant metering system
- scroll compressors with internal line-break overload protection
- easy access tool-less filter door. Filter track tilts out for filter removal and replacement. All filters are the same size in each unit.

Installation ease

All WeatherMaster units are field-convertible to horizontal airflow, which

1. BACnet is a registered trademark of ASHRAE (American Society of Heating, Refrigerating and Air-Conditioning Engineers).
2. LonWorks is a registered trademark of Echelon Corporation.
3. Modbus is a registered trademark of Schneider Electric.

makes it easy to adjust to unexpected job-site complications. Lighter units make for easy replacement. Simple, fast plug-in connections to the standard integrated unit control board (UCB). Clearly labeled connections points to reduce installation time. Also, a large control box provides room to work and room to mount Carrier accessory controls.

Easy to maintain

With the new EcoBlue Vane Axial fan system and direct drive ECM motor — there is no longer a need to adjust belts or pulleys as in past designs. This frees up maintenance and installation time.

Easy access handles by Carrier provide quick and easy access to all normally serviced components. Our “no-strip” screw system has superior holding power and guides screws into position while preventing the screw from stripping the unit’s metal.

Sloped, corrosion resistant composite drain pan sheds water; and won’t rust.

Easy to use

The newly re-designed Unit Control Board by Carrier puts all connections and troubleshooting points in one convenient place. Most low voltage connections are made to the same board and make it easy to access it. Setting up the fan is simple by an intuitive switch and rotary dial arrangement. Carrier rooftops have high and low pressure switches, a filter drier, and 2-in. filters standard.

Table of contents

	Page
Features/Benefits	2
Model Number Nomenclature	4
Capacity Ratings	5
Physical Data	6
Options and Accessories	8
Base Unit Dimensions	13
Accessory Dimensions	16
Performance Data	17
Fan Data	29
Electrical Data	54
Typical Wiring Diagrams	80
Sequence of Operation	90
Application Data	92
Guide Specifications	93

EcoBlue™ Technology

Direct drive EcoBlue Technology indoor fan system uses Vane Axial fan design and direct drive electrically commutated motors.

This new Vane Axial design over past belt drive systems has 75% fewer moving parts, uses up to 40% less energy and has no fan belts, blower bearings and shaft.

Streamlined control and integration

Carrier controllers make connecting WeatherMaster® rooftops into existing

building automation systems easy. The units are compatible with conventional thermostat controls, SystemVu™ controls and Carrier RTU Open multi-protocol controller.

Operating efficiency and flexibility

The 50GCQ rooftops exceed ASHRAE (American Society of Heating, Refrigerating, and Air-Conditioning Engineers) 90.1-2016, IECC¹-2018 (International

Energy Conservation Code) minimum efficiency requirements.

Field convertible airflow

All WeatherMaster 3 to 5 ton units are field-convertible to horizontal airflow, which makes it easy to adjust to unexpected job-site.

Comfort control

Carrier's Round Tube Plate Fin coils designs help maximize heat transfer and reliable operation.

1. IECC is a registered trademark of the International Code Council, Inc.



50GCQ MODEL NUMBER NOMENCLATURE

Position:	1	2	3	4	5	6	7	8	9	10	11	12	13	14	15	16	17	18
Example:	5	0	G	C	Q	M	0	4	A	1	A	5	-	0	A	0	A	0

Unit Heat Type
50 - Electric Heat
Packaged Rooftop

Model Series - WeatherMaster®
GC - 16 SEER Efficiency

Heat Options
Q = Heat Pump

Refrig. Systems Options
M = Two Stage Cooling Models

Cooling Tons
04 - 3 ton
05 - 4 ton
06 - 5 ton

Sensor Options
A = None
B = RA (Return Air) Smoke Detector
C = SA (Supply Air) Smoke Detector
D = RA + SA Smoke Detector
E = CO₂
F = RA Smoke Detector and CO₂
G = SA Smoke Detector and CO₂
H = RA + SA Smoke Detector and CO₂
J = Condensate Overflow Switch
K = Condensate Overflow Switch and RA Smoke Detectors
L = Condensate Overflow Switch and RA and SA Smoke Detectors
M = Condensate Overflow Switch and SA Smoke Detectors

Indoor Fan Options
1 = Direct Drive – EcoBlue – Standard Static
2 = Direct Drive – EcoBlue – Medium Static
3 = Direct Drive – EcoBlue – High Static

Coil Options (RTPF) (Outdoor - Indoor - Hail Guard)
A = Al/Cu - Al/Cu
B = Precoat Al/Cu - Al/Cu
C = E-coat Al/Cu - Al/Cu
D = E-coat Al/Cu - E-coat Al/Cu
E = Cu/Cu - Al/Cu
F = Cu/Cu - Cu/Cu
M = Al/Cu - Al/Cu — Louvered Hail Guard
N = Precoat Al/Cu - Al/Cu — Louvered Hail Guard
P = E-coat Al/Cu - Al/Cu — Louvered Hail Guard
Q = E-coat Al/Cu - E-coat Al/Cu — Louvered Hail Guard
R = Cu/Cu - Al/Cu — Louvered Hail Guard
S = Cu/Cu - Cu/Cu — Louvered Hail Guard

Factory Assigned
0 = Standard
1 = LTL

Electrical Options
A = None
B = HACR Breaker
C = Non-Fused Disconnect (NFD)
D = Thru-The-Base Connections (TTB)
E = HACR and Thru-The-Base Connections
F = Non-Fused Disconnect and TTB
N = Phase Monitor Protection
P = Phase Monitor and HACR
Q = Phase Monitor and NFD
R = Phase Monitor and TTB
S = Phase Monitor and HACR and TTB
T = Phase Monitor and NFD and TTB

Service Options
0 = None
1 = Unpowered Convenience Outlet
2 = Powered Convenience Outlet
3 = Hinged Panels
4 = Hinged Panels and
Unpowered Convenience Outlet
5 = Hinged Panels and
Powered Convenience Outlet
6 = MERV 8 Filters
C = Foil Faced Insulation

Intake / Exhaust Options
A = None
B = Temperature Economizer w/ Barometric Relief
F = Enthalpy Economizer w/ Barometric Relief
U = Temperature Ultra Low Leak Economizer w/
Barometric Relief
W = Enthalpy Ultra Low Leak Economizer w/
Barometric Relief

Base Unit Controls
0 = Electro-mechanical controls - can be used with
field-installed W7212 EconoMi\$er® IV
(Non-Fault Detection and Diagnostic)
2 = RTU Open Multi-Protocol Controller
3 = SystemVu™ Controller
6 = Electro-mechanical - can be used with W7220
EconoMi\$er X (with Fault Detection and Diagnostic)

Design Revision
- = Factory Design Revision

Voltage
1 = 575/3/60
3 = 208-230/1/60
5 = 208-230/3/60
6 = 460/3/60

Note: On single phase (-3 voltage code) models, the following are not available as factory-installed options:
- Coated Coils or Cu Fin Coils
- Louvered Hail Guards
- Economizer
- Powered 115 Volt Convenience Outlet

AHRI RATINGS

COOLING MODE

50GCQ	NOM. CAPACITY (tons)	NET COOLING CAPACITY (Btuh)	TOTAL POWER (kW)	SEER	EER
M04	3	35,000	2.8	16.2	12.5
M05	4	47,500	3.9	16.2	12.2
M06	5	60,000	4.9	16.2	12.2

HEATING MODE

50GCQ	HSPF	HIGH HEATING CAPACITY (Btuh)	HIGH HEAT COP	LOW HEATING CAPACITY (Btuh)	LOW HEAT COP
M04	8.3	34,000	3.8	17,600	2.4
M05	8.3	45,500	3.7	24,400	2.3
M06	8.3	55,500	3.9	30,000	2.4

LEGEND

- AHRI** — Air Conditioning, Heating and Refrigeration Institute
ASHRAE — American Society of Heating, Refrigerating and Air Conditioning Engineers
COP — Coefficient of Performance
EER — Energy Efficiency Ratio
HSPF — Heating Seasonal Performance Factor
SEER — Seasonal Energy Efficiency Ratio



NOTES:

- Rated and certified under AHRI Standard 210/240.
- Ratings are based on:
 Cooling Standard: 80°F (27°C) db, 67°F (19°C) wb indoor air temperature and 95°F (35°C) db outdoor air temperature.
 High Temperature Heating Ratings: 47°F (8°C) db, 43°F (6°C) wb outdoor air temperature and 70°F (21°C) entering indoor coil air.
 Low Temperature Heating Ratings: 17°F (-8°C) db, 15°F (-9°C) wb outdoor air temperature and 70°F (21°C) entering indoor coil air.
- All 50GCQ units comply with ASHRAE 90.1 Energy Standard for minimum SEER and EER requirements.

SOUND RATINGS TABLE

50GCQ UNIT	COOLING STAGES	OUTDOOR SOUND (dB) AT 60 Hz								
		A-WEIGHTED	63	125	250	500	1000	2000	4000	8000
M04	2	75.4	81.8	81.8	77.0	72.6	69.9	64.6	59.3	55.6
M05	2	79.0	85.6	84.7	80.5	76.0	72.4	68.0	62.8	59.3
M06	2	79.0	85.6	84.7	80.5	76.0	72.4	68.0	62.8	59.3

LEGEND

dB — Decibel

NOTES:

- Outdoor sound data is measured in accordance with AHRI.
- Measurements are expressed in terms of sound power. Do not compare these values to sound pressure values because sound pressure depends on specific environmental factors which normally do not match individual applications. Sound power values are independent of the environment and therefore more accurate.
- A-weighted sound ratings filter out very high and very low frequencies, to better approximate the response of "average" human ear. A-weighted measurements for Carrier units are taken in accordance with AHRI.

MINIMUM - MAXIMUM AIRFLOW RATINGS (CFM) — COOLING UNITS AND ACCESSORY ELECTRIC HEAT

UNIT	COOLING				ELECTRIC HEAT*	
	MINIMUM AIRFLOW CFM	MINIMUM 2-SPEED AIRFLOW (LOW SPEED)	MINIMUM 2-SPEED AIRFLOW (HIGH SPEED)	MAXIMUM AIRFLOW CFM	MINIMUM AIRFLOW CFM	MAXIMUM AIRFLOW CFM
50GCQM04	900	675	900	1500	900	1500
50GCQM05	1200	900	1200	2000	1200	2000
50GCQM06	1500	1125	1500	2500	1500	2500

* Electric heat modules are available as both factory-installed options or field-installed accessories for 50GCQ units.

50GCQ 3 TO 5 TON PHYSICAL DATA

50GCQ UNIT	50GCQM04	50GCQM05	50GCQM06
NOMINAL TONS	3	4	5
BASE UNIT OPERATING WT (lb)*	475	590	596
REFRIGERATION SYSTEM			
No. Circuits/No. Compressors/Type	1 / 1 / 2-Stage Scroll	1 / 1 / 2-Stage Scroll	1 / 1 / 2-Stage Scroll
Puron® (R-410A) Charge (lbs-oz)	10-3	11-3	15-0
Metering Device	TXV	TXV	TXV
High-Pressure Trip/Reset (psig)	630/505	630/505	630/505
Low-Pressure Trip/Reset (psig)	54/117	54/117	54/117
EVAPORATOR COIL (Indoor)			
Material (Tube/Fin)	Cu/Al	Cu/Al	Cu/Al
Coil Type	³ / ₈ -in. RTPF	³ / ₈ -in. RTPF	³ / ₈ -in. RTPF
Rows/FPI	3/15	3/15	4/15
Total Face Area (ft ²)	5.5	7.3	7.3
Condensate Drain Connection Size	³ / ₄ -in.	³ / ₄ -in.	³ / ₄ -in.
CONDENSER COIL (Outdoor)			
Material	Cu/Al	Cu/Al	Cu/Al
Coil Type	⁵ / ₁₆ -in. RTPF	⁵ / ₁₆ -in. RTPF	⁵ / ₁₆ -in. RTPF
Rows/FPI	2/18	2/18	2/18
Total Face Area (ft ²)	14.6	15.0	18.8
EVAPORATOR FAN AND MOTOR (Indoor)			
Standard Static 1 Phase			
Motor Qty/Drive Type	1/Direct	1/Direct	1/Direct
Max Cont BHP	0.44	0.72	1.06
RPM Range	189-1890	190-1900	215-2150
Fan Qty/Type	1/Vane Axial	1/Vane Axial	1/Vane Axial
Fan Diameter (in.)	16.6	16.6	16.6
Medium Static 1 Phase			
Motor Qty/Drive Type	1/Direct	1/Direct	1/Direct
Max Cont BHP	0.71	1.06	1.44
RPM Range	219-2190	217-2170	239-2390
Fan Qty/Type	1/Vane Axial	1/Vane Axial	1/Vane Axial
Fan Diameter (in.)	16.6	16.6	16.6
High Static 1 Phase			
Motor Qty/Drive Type	1/Direct	1/Direct	1/Direct
Max Cont BHP	1.07	1.53	1.96
RPM Range	249-2490	246-2460	266-2600
Fan Qty/Type	1/Vane Axial	1/Vane Axial	1/Vane Axial
Fan Diameter (in.)	16.6	16.6	16.6
Standard Static 3 Phase			
Motor Qty/Drive Type	1/Direct	1/Direct	1/Direct
Max Cont BHP	0.44	0.72	1.06
RPM Range	189-1890	190-1900	215-2150
Fan Qty/Type	1/Vane Axial	1/Vane Axial	1/Vane Axial
Fan Diameter (in.)	16.6	16.6	16.6
Medium Static 3 Phase			
Motor Qty/Drive Type	1/Direct	1/Direct	1/Direct
Max Cont BHP	0.71	1.06	1.44
RPM Range	219-2190	217-2170	239-2390
Fan Qty/Type	1/Vane Axial	1/Vane Axial	1/Vane Axial
Fan Diameter (in.)	16.6	16.6	16.6
High Static 3 Phase			
Motor Qty/Drive Type	1/Direct	1/Direct	1/Direct
Max Cont BHP	1.07	1.96	2.43
RPM Range	249-2490	266-2660	284-2836
Fan Qty/Type	1/Vane Axial	1/Vane Axial	1/Vane Axial
Fan Diameter (in.)	16.6	16.6	16.6



50GCQ 3 TO 5 TON PHYSICAL DATA (cont)

50GCQ UNIT	50GCQM04	50GCQM05	50GCQM06
CONDENSER FAN AND MOTOR (Outdoor)			
Qty / Motor Drive Type	1 / Direct	1 / Direct	1 / Direct
Motor HP/RPM	1/5 / 825/675	1/4 / 100/900	1/4 / 100/900
Fan Diameter (in.)	23	23	23
FILTERS			
RA Filter Qty / Size (in.)	2 / 16x25x2	4 / 16x16x2	4 / 16x16x2
OA Inlet Screen Qty / Size (in.)	1 / 20x24x1	1 / 20x24x1	1 / 20x24x1

LEGEND

- BHP** — Break Horsepower
- FPI** — Fins Per Inch
- OA** — Outdoor Air
- RA** — Return Air

* Base unit operating weight does not include weight of options.

Options and accessories



ITEM	OPTION*	ACCESSORY†
ELECTRIC HEAT		
Electric Resistance Heaters		X
Single Point Kits		X
CABINET		
Thru-the-Base electrical connections	X	X
Hinged Access Panels	X	
MERV-8 Filters	X	
COIL OPTIONS		
Cu/Cu indoor and/or outdoor coils ¹	X	
Pre-coated outdoor coils ¹	X	
Premium, E-coated outdoor coils ¹	X	
CONDENSER PROTECTION		
Condenser coil hail guard (louvered design) ¹	X	X
CONTROLS		
Thermostats, temperature sensors, and subbases		X
SystemVu™ DDC communicating controller	X	
RTU Open Multi-Protocol controller	X	
Smoke detector (supply and/or return air)	X	X
Horn Strobe Annunciator ²		X
Time Guard II compressor delay control circuit		X
Phase Monitor ¹	X	X
Condensate Overflow switch	X	X
FILTERS		
MERV-8 Return Air Filters	X	
ECONOMIZERS AND OUTDOOR AIR DAMPERS		
EconoMi\$er® IV for electro-mechanical controls - Non FDD (Standard air leak damper models) ^{1, 3}		X
EconoMi\$er2 for DDC controls (Standard and Ultra Low Leak air damper models) ^{1, 4}	X	X
EconoMi\$er X for electro-mechanical controls, complies with FDD (Standard and Ultra Low Leak damper models) ^{1, 3}	X	X
Motorized 2-position outdoor-air damper ¹		X
Manual outdoor-air damper (25% and 50%)		X
Barometric relief ⁵	X	X
Power exhaust - prop design		X

ITEM	OPTION*	ACCESSORY†
ECONOMIZER SENSORS AND IAQ DEVICES		
Single dry bulb temperature sensors ⁶	X	X
Differential dry bulb temperature sensors ⁶		X
Single enthalpy sensors ⁶	X	X
Differential enthalpy sensors ⁶		X
CO ₂ sensor (wall, duct, or unit mounted) ⁶	X	X
INDOOR MOTOR AND DRIVE		
Multiple motor and drive packages	X	
LOW AMBIENT CONTROL		
Winter start kit ⁷		X
Low Ambient controller to -20°F (-29°C) ⁷	X	X
POWER OPTIONS		
Convenience outlet (powered) ¹	X	
Convenience outlet (unpowered)	X	
HACR circuit breaker ⁸	X	
Non-fused disconnect ⁹	X	
ROOF CURBS		
Roof curb 14-in. (356 mm)		X
Roof curb 24-in. (610 mm)		X

* Factory-installed option.

† Field-installed accessory.

NOTES:

- Not available on single phase (-3 voltage code) models. Use field-installed accessory where available.
- Requires a field-supplied 24V transformer for each application. See price pages for details.
- FDD (Fault Detection and Diagnostic) capability per California Title 24 section 120.2.
- Models with SystemVu and RTU Open DDC controls comply with California Title 24 Fault Detection and Diagnostic (FDD).
- Included with economizer.
- Sensors used to optimize economizer performance.
- See application data for assistance.
- HACR circuit breaker cannot be used on 04-06 sizes when unit FLA electrical rating exceeds:
208/230/1/60 and 208/230/3/60 = 100 amps (FLA)
460/3/60 = 90 amps (FLA)
Carrier RTUBuilder automatically selects the amps limitations.
- Non-fused disconnect switch cannot be used when unit electrical rating exceeds:
Without factory-installed electric heat:
208-230/1/60 and 208-230/3/60 = 80 amps (FLA).
480/3/60 and 575/3/60 = 80 amps (FLA).
With factory-installed electric heat:
208-230/1/60 and 208-230/3/60 = 100 amps (FLA).
480/3/60 and 575/3/60 = 80 amps (FLA).
Carrier RTUBuilder automatically selects the amp limitations.

Factory-installed options

Economizer (dry-bulb or enthalpy)

Economizers save money. They bring in fresh, outside air for ventilation; and provide cool outside air to cool your building. This is the preferred method of low-ambient cooling. When coupled to CO₂ sensors, economizers can provide even more savings by coupling the ventilation air to only that amount required.

Economizers are available, installed and tested by the factory, with either enthalpy or dry-bulb temperature inputs. Additional sensors are available as accessories to optimize the economizers. Economizers include a powered exhaust system to help equalize building pressures.

Economizers include gravity controlled barometric relief that helps equalize building pressure and ambient air pressures. This can be a cost effective solution to prevent building pressurization. Economizers are available in Ultra Low Leak and standard low leak versions. Economizers can be factory-installed or easily field-installed.

Unit mounted CO₂ sensor

The CO₂ sensor works with the economizer to intake only the correct amount of outside air for ventilation. As occupants fill your building, the CO₂ sensor detects their presence through increasing CO₂ levels, and opens the economizer appropriately. When the occupants leave, the CO₂ levels decrease, and the sensor appropriately closes the economizer. This intelligent control of the ventilation air, called demand controlled ventilation (DCV) reduces the overall load on the rooftop, saving money. Also available as a field-installed accessory.

Smoke detector (supply and/or return air)

Trust the experts. Smoke detectors make your application safer and your job easier. Carrier smoke detectors immediately shut down the rooftop unit when smoke is detected. They are available, installed by the factory, for supply air, return air, or both.

Thru-the-base connection

Thru-the-base connections, available as a factory option, are necessary to ensure proper connection and seal when routing wire and piping through the rooftop's basepan and curb. These couplings eliminate roof penetration and should be considered for main power lines, as well as control power.

Hinged access panels

Allows access to unit's major components with specifically designed hinged access panels. Panels are filter, control box access indoor fan motor access.

Cu/Cu (indoor) coils

Copper fins and copper tubes are mechanically bonded to copper tubes and copper tube sheets. A polymer strip prevents coil assembly from contacting the sheet metal coil pan to minimize potential for galvanic corrosion between coil and pan.

E-coated (outdoor and indoor) coils

A flexible epoxy polymer coating uniformly applied to all coil surface areas without material bridging between fins. Coating process shall ensure complete coil encapsulation of tubes, fins and headers.

Pre-coated outdoor coils

A durable epoxy-phenolic coating to provide protection in mildly corrosive coastal environments. The coating minimizes galvanic action between dissimilar metals. Coating is applied to the aluminum fin stock prior to the fin stamping process to create an inert barrier between the aluminum fin and copper tube.

Condenser coil hail guard

Sleek, louvered panels protect the condenser coil from hail damage, foreign objects, and incidental contact.

Single enthalpy sensor

Prevents the wheel from rotating if the outside air conditions are acceptable for free cooling. Both exhaust and supply blowers will remain on.

Convenience outlet (powered or un-powered)

Reduce service and/or installation costs by including a convenience outlet in your specification. Carrier will install this service feature at our factory. Provides a convenient, 15 amp, 115v GFCI receptacle with "Wet in Use" cover. The "powered" option allows the installer to power the outlet from the line side of the disconnect or load side as required by code. The "unpowered" option is to be powered from a separate 115/120v power source.

The unpowered convenience outlet is available as a 15 amp factory-installed option or a 20 amp field-installed accessory.

HACR breaker

These manual reset devices provide overload and short circuit protection for the unit. Factory wired and mounted with the units with access cover to provide protection from the environment.

Non-fused disconnect

This OSHA-compliant, factory-installed, safety switch allows a service technician to locally secure power to the rooftop. When selecting a factory-installed non-fused disconnect, note they are sized for the unit as ordered from the factory. The sizing of these do not accommodate field-installed items such as power exhaust devices, etc. If field installing electric heat with factory-installed non-fused disconnect switch, a single point kit may or may not be required.

SystemVu™ controller

Carrier's SystemVu controller is an optional factory-installed and tested controller.

This controller takes on a whole new approach to provide an intuitive, intelligent controller that not only monitors and controls the unit, but also provides linkage to multiple building automation systems.

Each SystemVu controller makes it easy to set up, service, troubleshoot, gain historical data, generate reports and provide comfort only Carrier is noted for.

Key features include:

- Easy to read back lit four line text screen for superior visibility.
- Quick operational condition LEDs of: Run, Alert, and Fault.
- Simple navigation with large keypad buttons of: Navigation arrows, Test, Back, Enter and Menu.
- Capable of being controlled with a conventional thermostat, space sensor or build automation system.

- Service capabilities include:
 - Auto run test
 - Manual run test
 - Component run hours and starts
 - Commissioning reports
 - Data logging
- Full range of diagnosis:
 - Read refrigerant pressures without the need of gages
 - Sensor faults
 - Compressor reverse rotation
 - Economizer diagnostics that meet California Title 24 requirements
- Quick data transfer via USB port:
 - Unit configuration uploading/downloading
 - Data logging
 - Software upgrades
- Built in capacity for:
 - i-Vu® open systems
 - BACnet systems
 - CCN systems
- Configuration and alarm point capability:
 - Contain over 100 alarm codes
 - Contain over 260 status, troubleshooting, diagnostic and maintenance points
 - Contain over 270 control configuration setpoints

RTU Open, multi-protocol controller

Connect the rooftop to an existing BAS (building automation system) without needing complicated translators or adapter modules using the RTU Open controller. The RTU Open controller speaks the 4 most common building automation system languages (BACnet, Modbus, Johnson Controls N2, and LonWorks). Use this controller when you have an existing BAS. Besides the 4 protocols, it also communicates with a Carrier Open system (i-Vu and VVT®).

Condensate overflow switch

This sensor and related controller monitors the condensate level in the drain pan and shuts down compression operation when overflow conditions occur. It includes:

- Indicator light – solid red (more than 10 seconds on water contact – compressors disabled), blinking red (sensor disconnected)
- 10 second delay to break – eliminates nuisance trips from splashing or waves in pan (sensor needs 10 seconds of constant water contact before tripping)
- Disables the compressor(s) operation when condensate plug is detected, but still allows fans to run for economizer.

MERV-8 return air filters

This factory option upgrades the return air filters from standard unit filters to high efficiency MERV-8 filters. Non-woven MERV-8 filter media with high strength, moisture-resistant frame. Filter media is securely fastened inside the filter frame on all four sides.

Low ambient controller

The low ambient controller is a head pressure controller kit that is designed to maintain the unit's condenser head pressure during periods of low ambient cooling operation. This device should be used as an alternative to economizer free cooling when economizer usage is either not appropriate or desired. The low ambient controller will either cycle the outdoor fan motors or operate them at reduced speed to

maintain the unit operation, depending on the model. This controller allows cooling operation down to -20°F (-29°C) ambient conditions.

Field-installed accessories

Electric heaters and single point kits

Carrier offers a full-line of field-installed accessory heaters. The heaters are very easy to use, install and are all pre-engineered and certified. Electric heaters are available as either factory-installed options or field-installed accessories.

Filter maintenance indicator

When the optional factory-installed filter maintenance indicator is used, a factory-installed differential pressure switch measures pressure drop across the outside air filter and activates a field-supplied dry contact indicator when the pressure differential exceeds the adjustable switch setpoint.

Condenser coil hail guard

Sleek, louvered panels protect the condenser coil from hail damage, foreign objects, and incidental contact. This can be purchased as a factory-installed option or as a field-installed accessory.

Differential enthalpy sensor

The differential enthalpy sensor is comprised of an outdoor and return air enthalpy sensors to provide differential enthalpy control. The sensor allows the unit to determine if outside air is suitable for free cooling.

Wall or duct mounted CO₂ sensor

The IAQ sensor shall be available in duct or wall mount. The sensor provides demand ventilation indoor air quality (IAQ) control.

Winter start kit

The winter start kit by Carrier extends the low ambient limit of your rooftop to 25°F (-4°C). The kit bypasses the low pressure switch, preventing nuisance tripping of the low pressure switch. Other low ambient precautions may still be prudent.

Low ambient controller

The low ambient controller is a head pressure controller kit that is designed to maintain the unit's condenser head pressure during periods of low ambient cooling operation. This device should be used as an alternative to economizer free cooling not when economizer usage is either not appropriate or desired. The low ambient controller will either cycle the outdoor-fan motors or operate them at reduced speed to maintain the unit operation, depending on the model. This controller allows cooling operation down to -20°F (-29°C) ambient conditions.

Roof curb (14-in./356 mm or 24-in./610 mm)

Full perimeter roof curb with exhaust capability provides separate air streams for energy recovery from the exhaust air without supply air contamination.

Fan/filter status switch

Monitors static pressure across supply and exhaust filters and provides indication when filters become clogged.

Manual OA damper

Manual outdoor air dampers are an economical way to bring in ventilation air. The dampers are available in 25% and 50% versions.

Motorized 2-position damper

The Carrier 2-position, motorized outdoor air damper admits up to 100% outside air. Using reliable, gear-driven technology, the 2-position damper opens to allow ventilation air and closes when the rooftop stops, stopping unwanted infiltration.

Time Guard II control circuit

This accessory protects your compressor by preventing short-cycling in the event of some other failure, prevents the compressor from restarting for 30 seconds after stopping. Not required with SystemVu™ controller, RTU Open controller, or authorized commercial thermostats.

Power exhaust

Superior internal building pressure control. This field-installed accessory may eliminate the need for costly, external pressure control fans.

Phase monitor protection

The Phase Monitor Control will monitor the sequence of three phase electrical system to provide a phase reversal protection; and monitor the three phase voltage inputs to provide a phase loss protection for the three phase device. It will work on either a Delta or Wye power connection.

OPTIONS AND ACCESSORY WEIGHTS

OPTION / ACCESSORY NAME	50GCQ UNIT WEIGHT					
	04		05		06	
	lb	kg	lb	kg	lb	kg
Power Exhaust - Vertical	51	23	51	23	51	23
Power Exhaust - Horizontal	39	18	39	18	39	18
EconoMi\$er® (X, IV or 2)	35	16	35	16	35	16
2-Position Damper	39	18	39	18	39	18
Manual Damper	12	5	12	5	12	5
Hail Guard (louvered)	13	6	13	6	17	8
Cu/Cu Condenser Coil	37	17	74	34	90	41
Cu/Cu Condenser and Evaporator Coils	75	34	144	66	160	73
Roof Curb (14-in. curb)	95	43	95	43	95	43
Roof Curb (24-in. curb)	150	68	150	68	150	68
CO ₂ Sensor	2	1	2	1	2	1
Optional Indoor Motor/Drive	10	5	10	5	10	5
Low Ambient Controller	9	4	9	4	9	4
Winter Start Kit	5	2	5	2	5	2
Return Air Smoke Detector	7	3	7	3	7	3
Supply Air Smoke Detector	7	3	7	3	7	3
Fan Filter Switch	2	1	2	1	2	1
Non-Fused Disconnect	15	7	15	7	15	7
Powered Convenience Outlet	36	16	36	16	36	16
Unpowered Convenience Outlet	4	2	4	2	4	2
Enthalpy Sensor	2	1	2	1	2	1
Differential Enthalpy Sensor	3	1	3	1	3	1

NOTE: Where multiple variations are available, the heaviest combination is listed.

50GCQM04-06 BASE UNIT DIMENSIONS

- NOTES:
1. DIMENSIONS ARE IN INCHES, DIMENSIONS IN [] ARE IN MILLIMETERS.
 2. CENTER OF GRAVITY
 3. DIRECTION OF AIR FLOW
 4. ALL VIEW DRAWN USING 3RD ANGLE

UNIT	J	K
50GCQ*04	33 3/8 [847]	18 5/8 [472]
50GCQ*05	41 3/8 [1051]	18 5/8 [472]
50GCQ*06	41 3/8 [1051]	18 5/8 [472]



THIS DOCUMENT IS THE PROPERTY OF UTC CLIMATE, CONTROLS & SECURITY AND IS DELIVERED UPON THE EXPRESS CONDITION THAT THE CONTENTS WILL NOT BE DISCLOSED OR USED WITHOUT WRITTEN CONSENT.

SUBMISSION OF THESE DRAWINGS OR DOCUMENTS DOES NOT CONSTITUTE PART PERFORMANCE OR ACCEPTANCE OF CONTRACT.

CONNECTION SIZES	
A	1 3/8" [35] DIA FIELD POWER SUPPLY HOLE
B	2" [51] DIA POWER SUPPLY KNOCKOUT
C	1 3/4" [44] DIA GAUGE ACCESS PLUG
D	7/8" [22] DIA FIELD CONTROL WIRING HOLE
E	3/4"-14 NPT CONDENSATE DRAIN
G	2 1/2" [64] DIA POWER SUPPLY KNOCK-OUT

THRU-THE-BASE CHART THESE HOLES REQUIRED FOR USE CRBTMPWR008A00, 009A00			
	THREADED CONDUIT SIZE	WIRE USE	REQ'D HOLE SIZES (MAX.)
W	1/2"	115V	7/8" [22.2]
X	1/2"	24V	7/8" [22.2]
Y *	3/4"	POWER	1 1/8" [28.6]
Z **	(009A00) 1/2" FPT	GAS	1 1/8" [28.6]

FOR "THRU-THE-BASEPAN" FACTORY OPTION, FITTINGS FOR ONLY X, Y, & Z ARE PROVIDED

* SELECT EITHER 3/4" OR 1/2" FOR POWER, DEPENDING ON WIRE SIZE

** (008A00) PROVIDES 3/4" FPT THRU CURB FLANGE & FITTING.

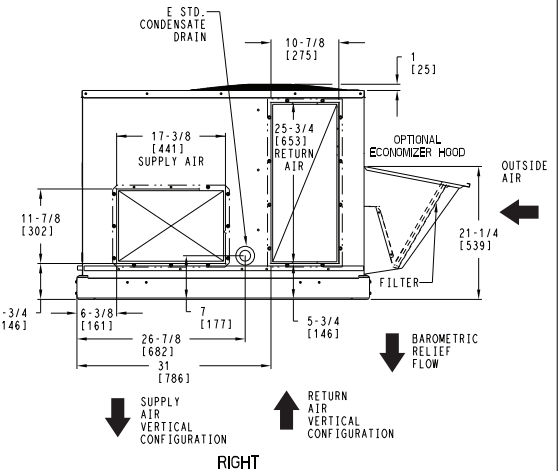
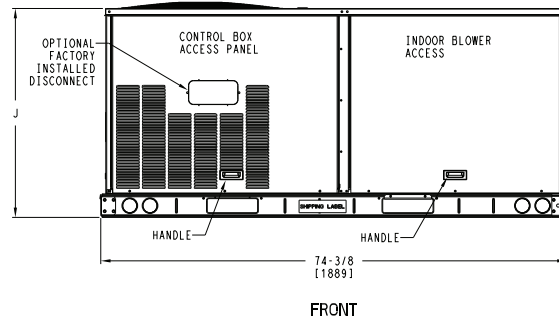
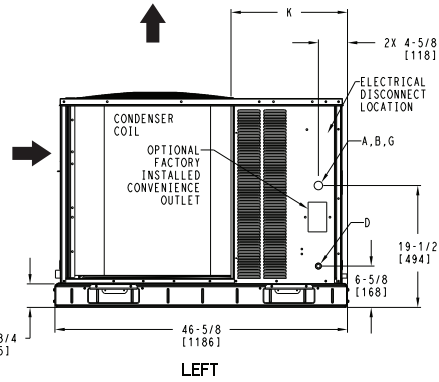
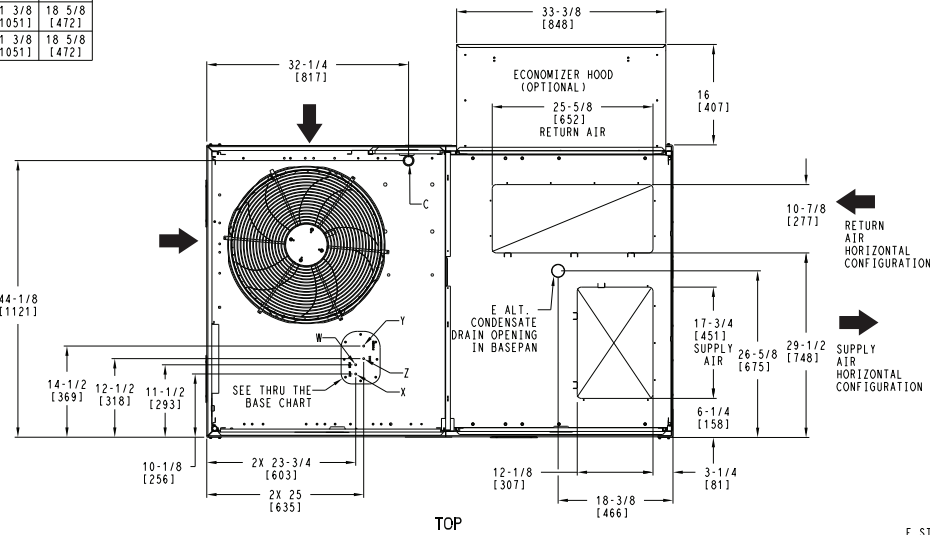

ITC CLASSIFICATION	SHEET	DATE	SUPERCEDES	50GCQ 04-06 SINGLE PACKAGE HEAT PUMP	48TC003351	REV
U.S. ECCN:NSR	1 OF 3	08/15/19	-			-



50GCQM04-06 BASE UNIT DIMENSIONS (cont)

Carrier UNITED TECHNOLOGIES
 THIS DOCUMENT IS THE PROPERTY OF UTC CLIMATE, CONTROLS & SECURITY AND IS DELIVERED UPON THE EXPRESS CONDITION THAT THE CONTENTS WILL NOT BE DISCLOSED OR USED WITHOUT WRITTEN CONSENT.
 SUBMISSION OF THESE DRAWINGS OR DOCUMENTS DOES NOT CONSTITUTE PART PERFORMANCE OR ACCEPTANCE OF CONTRACT.

UNIT	STD. UNIT WEIGHT *		CORNER WEIGHT (A)		CORNER WEIGHT (B)		CORNER WEIGHT (C)		CORNER WEIGHT (D)		C.G.			HEIGHT
	LBS.	KG.	LBS.	KG.	LBS.	KG.	LBS.	KG.	LBS.	KG.	X	Y	Z	
50GCO-04	475	215	128	58	120	54	110	50	117	53	36 [914]	22 3/8 [568]	16 1/8 [410]	
50GCO-05	590	268	162	73	147	67	134	61	148	67	35 3/8 [898]	22 5/16 [557]	16 1/2 [419]	
50GCO-06	596	270	163	74	148	67	125	61	149	68	35 3/8 [898]	22 5/16 [557]	16 1/2 [419]	

* - STANDARD UNIT WEIGHT IS WITHOUT ELECTRIC HEAT AND WITHOUT PACKAGING.
 FOR OTHER OPTIONS AND ACCESSORIES REFER TO THE PRODUCT DATA CATALOG.

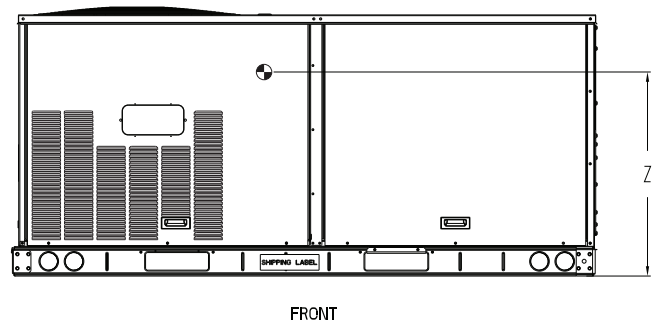
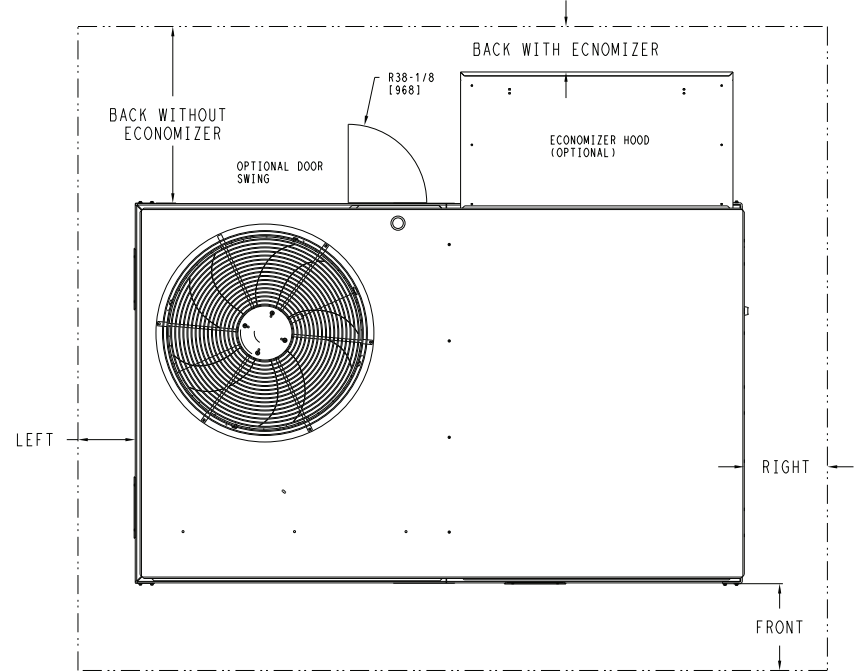
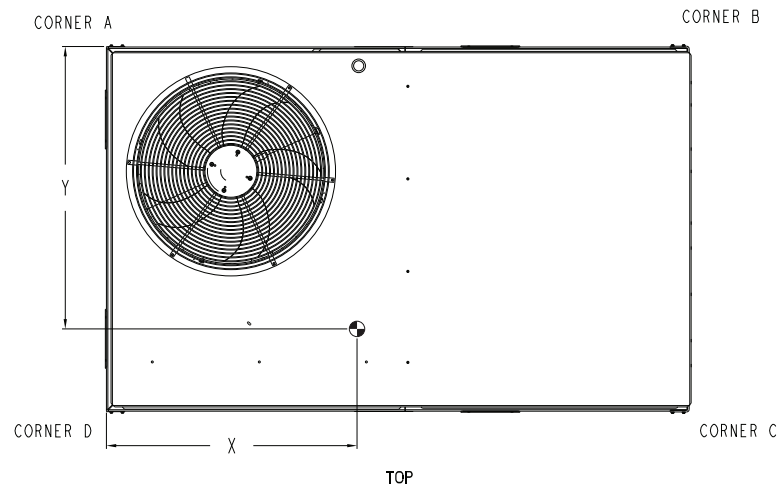

NOTE:
 1. FOR ALL MINIMUM CLEARANCES LOCAL CODES OR JURISDICTIONS MAY PREVAIL.

SURFACE	CLEARANCE		OPERATING CLEARANCE
	SERVICE WITH CONDUCTIVE BARRIER	SERVICE WITH NONCONDUCTIVE BARRIER	
FRONT	48 [1219mm]	36 [914mm]	18 [457mm]
LEFT	48 [1219mm]	42 [1067mm]	18 [457mm]
BACK W/O ECON	48 [1219mm]	42 [1067mm]	18 [457mm]
BACK W/ECON	36 [914mm]	36 [914mm]	18 [457mm]
RIGHT	36 [914mm]	36 [914mm]	18 [457mm]
TOP	72 [1829mm]	72 [1829mm]	72 [1829mm]

ITC CLASSIFICATION	SHEET	DATE	SUPERCEDES	50GCO 04-06 SINGLE PACKAGE HEAT PUMP	REV
U.S. ECCN:NSR	2 OF 3	08/15/19	-		48TC003351



50GCQM04-06 BASE UNIT DIMENSIONS (cont)



THIS DOCUMENT IS THE PROPERTY OF UTC CLIMATE CONTROLS & SECURITY AND IS DELIVERED UPON THE EXPRESS CONDITION THAT THE CONTENTS WILL NOT BE DISCLOSED OR USED WITHOUT WRITTEN CONSENT.

SUBMISSION OF THESE DRAWINGS OR DOCUMENTS DOES NOT CONSTITUTE PART PERFORMANCE OR ACCEPTANCE OF CONTRACT.

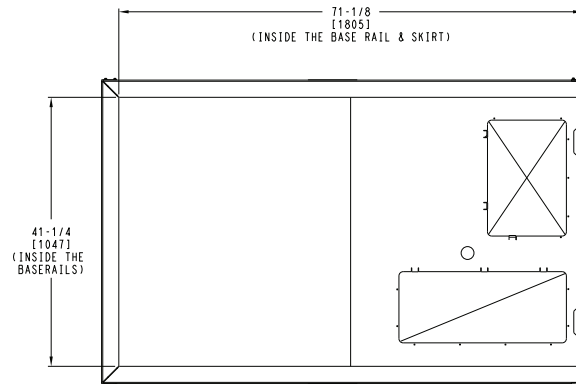
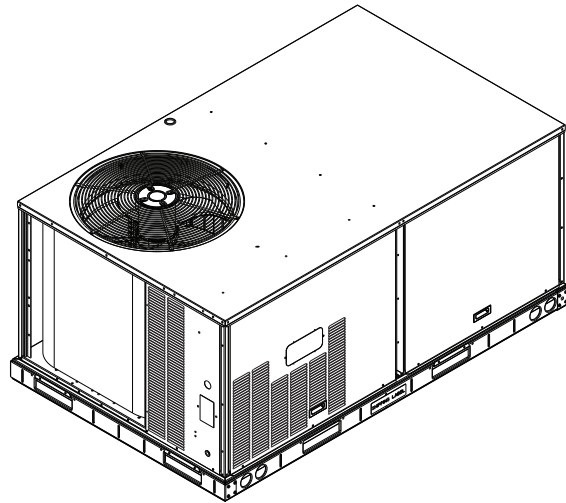

INSIDE BASERAIL DIMENSIONS
BOTTOM

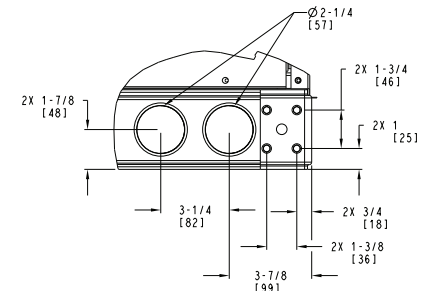

DETAIL C
TYP 4 PLCS

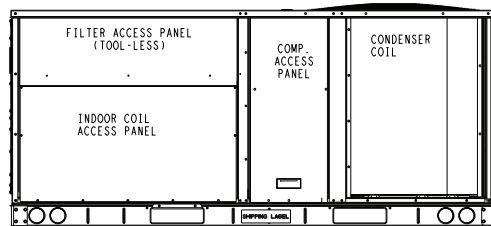

BACK

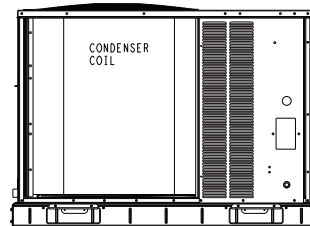

LEFT

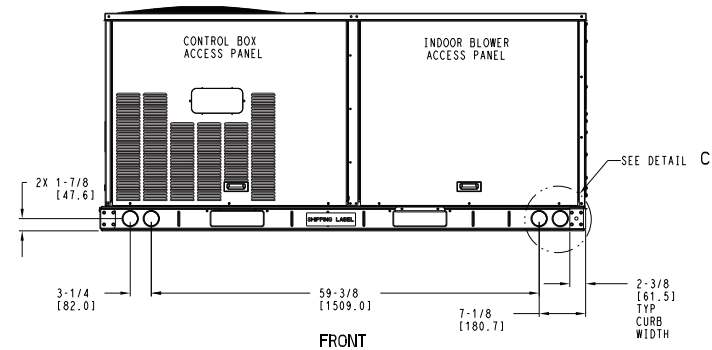

FRONT

ITC CLASSIFICATION	SHEET	DATE	SUPERCEDES	50GCO 04-06 SINGLE PACKAGE HEAT PUMP	48TC003351	REV
U.S. ECCN:NSR	3 OF 3	08/15/19	-			-



ROOF CURB DIMENSIONS — 50GCQM04-06

ROOF CURB ACCESSORY #	A
CRRFCURB001A01	14" [356]
CRRFCURB002A01	24" [610]

- NOTES:
1. ROOFCURB ACCESSORY IS SHIPPED DISASSEMBLED.
 2. INSULATED PANELS: 25.4 [1"] THK. POLYURETHANE FOAM, 44.5 [1-3/4"] # DENSITY.
 3. DIMENSIONS IN [] ARE IN MILLIMETERS.
 4. ROOFCURB: 18 GAGE STEEL.
 5. ATTACH DUCTWORK TO CURB. (FLANGES OF DUCT REST ON CURB).
 6. SERVICE CLEARANCE 4 FEET ON EACH SIDE.
 7. DIRECTION OF AIR FLOW.
 8. CONNECTOR PACKAGE CRBTMPWR001A01 IS FOR THRU-THE-CURB GAS TYPE PACKAGE CRBTMPWR003A01 IS FOR THRU-THE-BOTTOM TYPE GAS CONNECTIONS.

CONNECTOR PKG. ACC.	GAS CONNECTION TYPE	GAS FITTING	POWER WIRING FITTING	CONTROL WIRING FITTING	ACCESSORY CONVENIENCE OUTLET WIRING CONNECTOR
CRBTMPWR001A01	THRU THE CURB	3/4" [19] NPT	3/4" [19] NPT	1/2" [12.7] NPT	1/2" [12.7] NPT
CRBTMPWR003A01	THRU THE BOTTOM	1/2" [12.7] NPT			

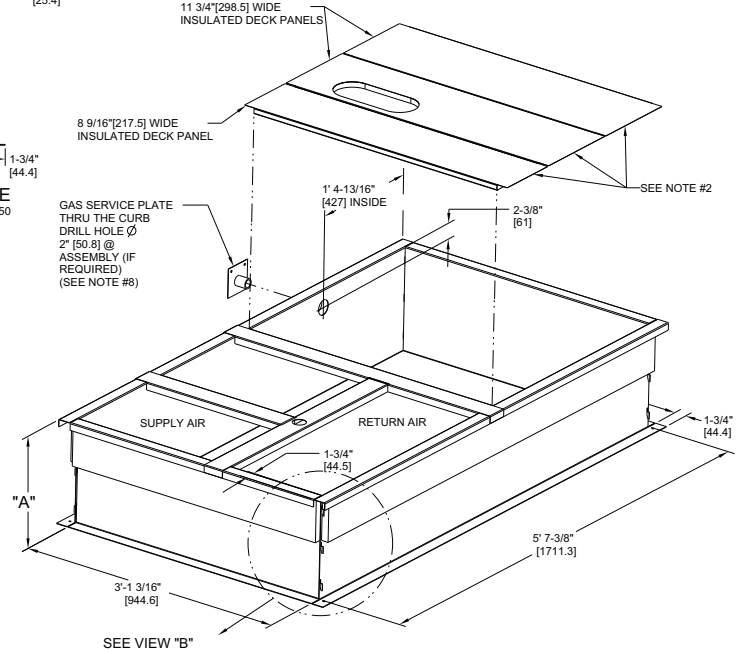
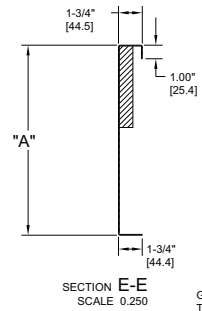
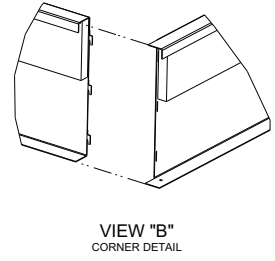
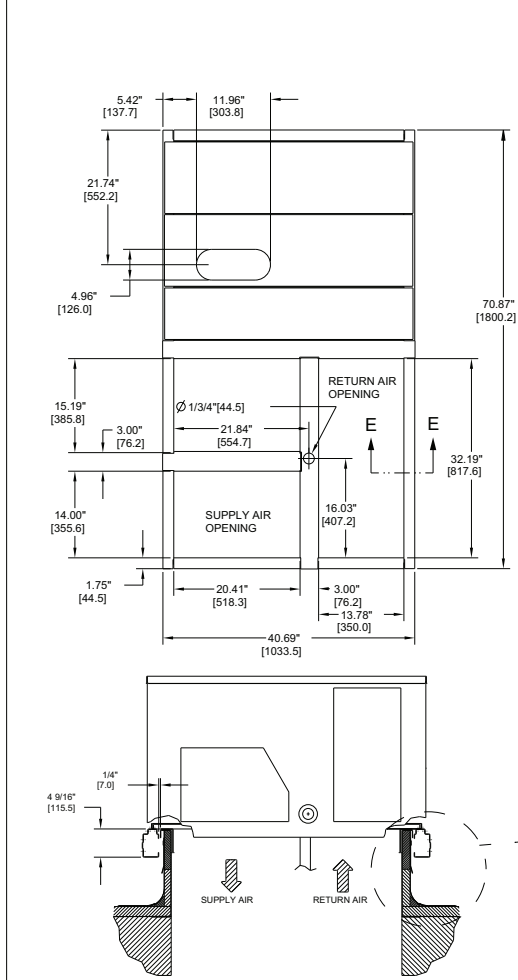

CERTIFIED DRAWING

DRAWING RELEASE LEVEL: PRODUCTION		TITLE: CURB ASY, ROOF	
THIRD ANGLE PROJECTION	UNLESS OTHERWISE SPECIFIED DIMENSIONS ARE IN INCHES TOLERANCES ON:		
MATERIAL	1 DEC ±.1	2 DEC ±.05	3 DEC ±.02
ENGINEERING REQUIREMENTS	AUTHORIZATION NUMBER: 1041738		REV: B
WEIGHT: -	ENGINEERING	MANUFACTURING	SIZE: D
SURFACE FINISH: -	DRAFTER: MMC	CHECKER: 06/17/11	DRAWING NUMBER: 48TC400427
MFG/PURCH: PURCH	MODEL (INTERNAL USE ONLY)		SHEET 5 OF 5
	NEXT DRAWING: -	SCALE: N/A	DISTRIBUTION: MMC

REV	REVISION RECORD	DATE	BY	CHKD	APPD	ECN NO.
A	OVERALL DIM. 5'-7 3/8" WAS 5'-7 7/8"; 18GA MATERIAL WA 16 GA.; NAIL FIELD SUPPLIED WAS WITH CURB	04/22/13	MMC	-	-	1067898



50GCQM04 HIGH STAGE COOLING CAPACITIES

50GCQM04			AMBIENT TEMPERATURE (F)																
			85			95			105			115			125				
			EAT (db)			EAT (db)			EAT (db)			EAT (db)			EAT (db)				
			75	80	85	75	80	85	75	80	85	75	80	85	75	80	85		
900 Cfm	EAT (wb)	58	TC	30.8	30.8	35.0	28.9	28.9	33.0	27.0	27.0	30.8	24.8	24.8	28.5	22.5	22.5	25.9	
			SHC	26.6	30.8	35.0	24.9	28.9	33.0	23.1	27.0	30.8	21.2	24.8	28.5	19.1	22.5	25.9	
		62	TC	32.6	32.6	33.5	30.3	30.3	32.1	27.9	27.9	30.7	25.3	25.3	29.1	22.6	22.6	27.0	
			SHC	24.1	28.8	33.5	22.7	27.4	32.1	21.3	26.0	30.7	19.7	24.4	29.1	17.9	22.4	27.0	
		67	TC	36.3	36.3	36.3	33.9	33.9	33.9	31.3	31.3	31.3	28.5	28.5	28.5	25.4	25.4	25.4	
			SHC	19.8	24.4	29.1	18.4	23.1	27.8	17.0	21.7	26.4	15.5	20.2	24.9	13.9	18.7	23.4	
	72	TC	40.3	40.3	40.3	37.8	37.8	37.8	35.0	35.0	35.0	32.0	32.0	32.0	28.7	28.7	28.7		
		SHC	15.4	19.9	24.5	14.1	18.6	23.2	12.7	17.3	21.9	11.2	15.8	20.4	9.6	14.2	18.9		
	76	TC	—	43.7	43.7	—	41.0	41.0	—	38.1	38.1	—	34.9	34.9	—	31.4	31.4		
		SHC	—	16.1	21.1	—	14.9	19.9	—	13.6	17.7	—	12.2	16.5	—	10.7	15.1		
	1050 Cfm	EAT (wb)	58	TC	32.8	32.8	37.2	30.8	30.8	35.1	28.7	28.7	32.8	26.5	26.5	30.3	24.0	24.0	27.5
				SHC	28.3	32.8	37.2	26.6	30.8	35.1	24.7	28.7	32.8	22.6	26.5	30.3	20.4	24.0	27.5
62			TC	33.8	33.8	37.0	31.4	31.4	35.6	28.9	28.9	33.9	26.8	26.8	30.8	24.0	24.0	28.8	
			SHC	26.2	31.6	37.0	24.8	30.2	35.6	23.2	28.6	33.9	21.0	25.9	30.8	19.2	24.0	28.8	
67			TC	37.5	37.5	37.5	35.0	35.0	35.0	32.3	32.3	32.3	29.4	29.4	29.4	26.1	26.1	26.2	
			SHC	21.2	26.6	32.0	19.8	25.2	30.7	18.4	23.8	29.2	16.9	22.3	27.7	15.3	20.7	26.2	
72		TC	41.6	41.6	41.6	38.9	38.9	38.9	36.0	36.0	36.0	32.9	32.9	32.9	29.4	29.4	29.4		
		SHC	16.1	21.4	26.7	14.7	20.1	25.4	13.3	18.6	24.0	11.8	17.2	22.5	10.2	15.6	21.0		
76		TC	—	45.0	45.0	—	42.2	42.2	—	39.2	39.2	—	35.8	35.8	—	32.2	32.2		
		SHC	—	17.1	21.8	—	15.8	20.7	—	14.4	19.5	—	13.0	18.1	—	11.4	16.7		
1200 Cfm		EAT (wb)	58	TC	34.5	34.5	39.1	32.4	32.4	36.9	30.2	30.2	34.4	27.8	27.8	31.8	25.2	25.2	28.9
				SHC	29.8	34.5	39.1	28.0	32.4	36.9	26.0	30.2	34.4	23.8	27.8	31.8	21.4	25.2	28.9
	62		TC	34.8	34.8	40.2	32.7	32.7	37.8	30.3	30.3	35.9	27.8	27.8	33.2	25.2	25.2	30.2	
			SHC	28.1	34.2	40.2	26.3	32.0	37.8	24.6	30.3	35.9	22.5	27.8	33.2	20.2	25.2	30.2	
	67		TC	38.5	38.5	38.5	35.9	35.9	35.9	33.1	33.1	33.1	30.0	30.0	30.5	26.7	26.7	28.8	
			SHC	22.6	28.7	34.8	21.2	27.3	33.5	19.7	25.9	32.0	18.2	24.3	30.5	16.5	22.7	28.8	
	72	TC	42.6	42.6	42.6	39.8	39.8	39.8	36.8	36.8	36.8	33.5	33.5	33.5	30.0	30.0	30.0		
		SHC	16.7	22.7	28.8	15.3	21.4	27.4	13.9	20.0	26.0	12.3	18.4	24.5	10.7	16.9	23.0		
	76	TC	—	46.1	46.1	—	43.1	43.1	—	40.0	40.0	—	36.5	36.5	—	32.8	32.8		
		SHC	—	17.9	23.6	—	16.6	22.4	—	15.2	21.0	—	13.7	19.6	—	12.1	18.1		
	1350 Cfm	EAT (wb)	58	TC	35.9	35.9	40.7	33.8	33.8	38.4	31.5	31.5	35.8	28.9	28.9	33.1	26.2	26.2	30.0
				SHC	31.1	35.9	40.7	29.2	33.8	38.4	27.1	31.5	35.8	24.8	28.9	33.1	22.3	26.2	30.0
62			TC	35.9	35.9	42.4	33.8	33.8	39.9	31.5	31.5	37.3	29.0	29.0	34.5	26.2	26.2	31.3	
			SHC	29.5	35.9	42.4	27.7	33.8	39.9	25.7	31.5	37.3	23.5	29.0	34.5	21.1	26.2	31.3	
67			TC	39.2	39.2	39.2	36.6	36.6	36.6	33.7	33.7	34.7	30.5	30.5	33.1	27.1	27.1	31.4	
			SHC	23.9	30.7	37.5	22.4	29.3	36.1	21.0	27.8	34.7	19.4	26.2	33.1	17.7	24.5	31.4	
72		TC	43.3	43.3	43.3	40.5	40.5	40.5	37.4	37.4	37.4	34.1	34.1	34.1	30.4	30.4	30.4		
		SHC	17.3	24.0	30.8	15.9	22.7	29.4	14.4	21.2	28.0	12.9	19.7	26.5	11.3	18.1	24.9		
76		TC	—	46.8	46.8	—	43.9	43.9	—	40.6	40.6	—	37.1	37.1	—	33.3	33.3		
		SHC	—	18.6	25.1	—	17.3	23.8	—	15.9	22.5	—	14.4	21.0	—	12.8	19.5		
1500 Cfm		EAT (wb)	58	TC	37.1	37.1	42.1	34.9	34.9	39.6	32.5	32.5	37.0	29.9	29.9	34.1	27.0	27.0	31.0
				SHC	32.2	37.1	42.1	30.2	34.9	39.6	28.0	32.5	37.0	25.7	29.9	34.1	23.1	27.0	31.0
	62		TC	37.2	37.2	43.8	35.0	35.0	41.3	32.6	32.6	38.6	29.9	29.9	35.6	27.1	27.1	32.3	
			SHC	30.6	37.2	43.8	28.6	35.0	41.3	26.6	32.6	38.6	24.3	29.9	35.6	21.8	27.1	32.3	
	67		TC	39.9	39.9	40.1	37.1	37.1	38.7	34.2	34.2	37.2	31.0	31.0	35.6	27.5	27.5	33.8	
			SHC	25.1	32.6	40.1	23.7	31.2	38.7	22.1	29.7	37.2	20.5	28.0	35.6	18.8	26.3	33.8	
	72	TC	44.0	44.0	44.0	41.1	41.1	41.1	37.9	37.9	37.9	34.5	34.5	34.5	30.8	30.8	30.8		
		SHC	17.8	25.3	32.7	16.4	23.9	31.4	14.9	22.4	29.9	13.4	20.9	28.4	11.7	19.3	26.8		
	76	TC	—	47.5	47.5	—	44.4	44.4	—	41.1	41.1	—	37.5	37.5	—	33.7	33.7		
		SHC	—	19.3	26.5	—	18.0	25.2	—	16.5	23.8	—	15.0	22.4	—	13.4	20.8		

LEGEND

- Do Not Operate
- Cfm** — Cubic Feet Per Minute (Supply Air)
- EAT (db)** — Entering Air Temperature (dry bulb)
- EAT (wb)** — Entering Air Temperature (wet bulb)
- SHC** — Sensible Heat Capacity (1000 Btuh) Gross
- TC** — Total Capacity (1000 Btuh) Gross

NOTE: See minimum-maximum airflow ratings on page 5.

50GCQM04 LOW STAGE COOLING CAPACITIES

50GCQM04			AMBIENT TEMPERATURE (F)																
			85			95			105			115			125				
			EAT (db)			EAT (db)			EAT (db)			EAT (db)			EAT (db)				
			75	80	85	75	80	85	75	80	85	75	80	85	75	80	85		
750 Cfm	EAT (wb)	58	TC	23.2	23.2	26.2	22.0	22.0	24.9	20.8	20.8	23.5	19.4	19.4	21.9	17.9	17.9	20.2	
			SHC	20.2	23.2	26.2	19.2	22.0	24.9	18.1	20.8	23.5	16.8	19.4	21.9	15.5	17.9	20.2	
		62	TC	23.7	23.7	26.3	22.3	22.3	25.5	21.3	21.3	22.9	19.4	19.4	22.8	17.9	17.9	21.0	
			SHC	18.9	22.6	26.3	18.1	21.8	25.5	16.5	19.7	22.9	16.0	19.4	22.8	14.7	17.9	21.0	
		67	TC	26.4	26.4	26.4	24.8	24.8	24.8	23.1	23.1	23.1	21.2	21.2	21.2	19.2	19.2	19.8	
			SHC	15.4	19.1	22.8	14.7	18.4	22.1	13.9	17.7	21.4	13.1	16.9	20.6	12.3	16.0	19.8	
	72	TC	29.3	29.3	29.3	27.6	27.6	27.6	25.8	25.8	25.8	23.8	23.8	23.8	21.5	21.5	21.5		
		SHC	11.8	15.4	19.0	11.1	14.7	18.4	10.4	14.0	17.7	9.6	13.3	16.9	8.7	12.4	16.1		
	76	TC	—	31.6	31.6	—	29.9	29.9	—	28.0	28.0	—	25.9	25.9	—	23.5	23.5		
		SHC	—	12.3	16.4	—	11.7	14.8	—	11.0	14.4	—	10.3	13.7	—	9.5	13.0		
	900 Cfm	EAT (wb)	58	TC	24.7	24.7	27.9	23.4	23.4	26.5	22.1	22.1	24.9	20.6	20.6	23.3	18.9	18.9	21.4
				SHC	21.5	24.7	27.9	20.4	23.4	26.5	19.2	22.1	24.9	17.9	20.6	23.3	16.4	18.9	21.4
62			TC	25.0	25.0	28.2	23.5	23.5	27.5	22.1	22.1	25.9	20.6	20.6	24.2	19.0	19.0	22.3	
			SHC	20.1	24.1	28.2	19.4	23.5	27.5	18.3	22.1	25.9	17.0	20.6	24.2	15.6	19.0	22.3	
67			TC	27.2	27.2	27.2	25.6	25.6	25.6	23.8	23.8	24.0	21.8	21.8	23.2	19.7	19.7	22.3	
			SHC	16.6	21.0	25.4	15.9	20.3	24.7	15.1	19.5	24.0	14.3	18.7	23.2	13.4	17.8	22.3	
72		TC	30.1	30.1	30.1	28.4	28.4	28.4	26.5	26.5	26.5	24.4	24.4	24.4	22.1	22.1	22.1		
		SHC	12.3	16.6	20.9	11.6	16.0	20.3	10.9	15.2	19.6	10.1	14.4	18.8	9.2	13.6	18.0		
76		TC	—	32.7	32.7	—	30.8	30.8	—	28.8	28.8	—	26.6	26.6	—	24.1	24.1		
		SHC	—	13.1	17.0	—	12.4	16.5	—	11.7	15.9	—	11.0	15.2	—	10.1	14.4		
1050 Cfm		EAT (wb)	58	TC	25.9	25.9	29.2	24.6	24.6	27.7	23.1	23.1	26.1	21.6	21.6	24.4	19.8	19.8	22.4
				SHC	22.6	25.9	29.2	21.4	24.6	27.7	20.1	23.1	26.1	18.7	21.6	24.4	17.2	19.8	22.4
	62		TC	25.9	25.9	30.4	24.6	24.6	28.9	23.2	23.2	27.2	21.6	21.6	25.3	19.8	19.8	23.3	
			SHC	21.5	25.9	30.4	20.4	24.6	28.9	19.2	23.2	27.2	17.8	21.6	25.3	16.3	19.8	23.3	
	67		TC	27.9	27.9	27.9	26.2	26.2	27.1	24.3	24.3	26.4	22.3	22.3	25.5	20.1	20.1	24.4	
			SHC	17.7	22.8	27.8	17.0	22.1	27.1	16.2	21.3	26.4	15.4	20.5	25.5	14.4	19.4	24.4	
	72	TC	30.8	30.8	30.8	29.0	29.0	29.0	27.0	27.0	27.0	24.9	24.9	24.9	22.5	22.5	22.5		
		SHC	12.8	17.8	22.7	12.1	17.1	22.1	11.4	16.4	21.4	10.5	15.6	20.6	9.7	14.7	19.8		
	76	TC	—	33.4	33.4	—	31.5	31.5	—	29.4	29.4	—	27.1	27.1	—	24.6	24.6		
		SHC	—	13.7	18.5	—	13.1	17.9	—	12.4	17.2	—	11.6	16.5	—	10.8	15.7		
	1200 Cfm	EAT (wb)	58	TC	26.9	26.9	30.4	25.5	25.5	28.8	24.0	24.0	27.1	22.3	22.3	25.2	20.5	20.5	23.2
				SHC	23.5	26.9	30.4	22.2	25.5	28.8	20.9	24.0	27.1	19.4	22.3	25.2	17.8	20.5	23.2
62			TC	26.9	26.9	31.6	25.5	25.5	29.9	24.0	24.0	28.2	22.4	22.4	26.3	20.5	20.5	24.1	
			SHC	22.3	26.9	31.6	21.2	25.5	29.9	19.9	24.0	28.2	18.5	22.4	26.3	16.9	20.5	24.1	
67			TC	28.4	28.4	30.2	26.6	26.6	29.5	24.7	24.7	28.6	22.6	22.6	27.6	20.6	20.6	25.7	
			SHC	18.8	24.5	30.2	18.1	23.8	29.5	17.3	22.9	28.6	16.3	22	27.6	15.1	20.4	25.7	
72		TC	31.3	31.3	31.3	29.4	29.4	29.4	27.4	27.4	27.4	25.2	25.2	25.2	22.8	22.8	22.8		
		SHC	13.3	18.9	24.5	12.6	18.2	23.8	11.8	17.5	23.1	11.0	16.7	22.3	10.1	15.8	21.5		
76		TC	—	33.9	33.9	—	32.0	32.0	—	29.8	29.8	—	27.5	27.5	—	24.9	24.9		
		SHC	—	14.3	19.8	—	13.7	19.1	—	12.9	18.5	—	12.2	17.7	—	11.3	16.9		
1350 Cfm		EAT (wb)	58	TC	27.8	27.8	31.3	26.3	26.3	29.7	24.8	24.8	27.9	23.0	23.0	26.0	21.1	21.1	23.8
				SHC	24.2	27.8	31.3	22.9	26.3	29.7	21.6	24.8	27.9	20.0	23.0	26.0	18.3	21.1	23.8
	62		TC	27.8	27.8	32.5	26.3	26.3	30.8	24.7	24.7	29.0	23.0	23.0	27.0	21.1	21.1	24.8	
			SHC	23.0	27.8	32.5	21.8	26.3	30.8	20.5	24.7	29.0	19.0	23.0	27.0	17.4	21.1	24.8	
	67		TC	28.7	28.7	32.4	27.0	27.0	31.5	25.0	25.0	30.6	23.1	23.1	28.7	21.1	21.1	26.7	
			SHC	19.8	26.1	32.4	19.0	25.3	31.5	18.2	24.4	30.6	17.0	22.8	28.7	15.6	21.1	26.7	
	72	TC	31.7	31.7	31.7	29.8	29.8	29.8	27.8	27.8	27.8	25.5	25.5	25.5	23.0	23.0	23.1		
		SHC	13.7	19.9	26.2	13.0	19.2	25.5	12.2	18.5	24.8	11.4	17.7	24.0	10.5	16.8	23.1		
	76	TC	—	34.4	34.4	—	32.4	32.4	—	30.2	30.2	—	27.8	27.8	—	25.2	25.2		
		SHC	—	14.9	21.0	—	14.2	20.4	—	13.5	19.7	—	12.7	18.9	—	11.9	18.1		

LEGEND

- Do Not Operate
- Cfm** — Cubic Feet Per Minute (Supply Air)
- EAT (db)** — Entering Air Temperature (dry bulb)
- EAT (wb)** — Entering Air Temperature (wet bulb)
- SHC** — Sensible Heat Capacity (1000 Btuh) Gross
- TC** — Total Capacity (1000 Btuh) Gross

NOTE: See minimum-maximum airflow ratings on page 5.



50GCQM05 HIGH STAGE COOLING CAPACITIES

50GCQM05			AMBIENT TEMPERATURE (F)																
			85			95			105			115			125				
			EAT (db)			EAT (db)			EAT (db)			EAT (db)			EAT (db)				
			75	80	85	75	80	85	75	80	85	75	80	85	75	80	85		
1200 Cfm	EAT (wb)	58	TC	41.7	41.7	47.4	39.2	39.2	44.7	36.6	36.6	41.8	33.7	33.7	38.6	30.7	30.7	35.4	
			SHC	36.0	41.7	47.4	33.8	39.2	44.7	31.3	36.6	41.8	28.7	33.7	38.6	26.1	30.7	35.4	
		62	TC	44.1	44.1	45.3	41.0	41.0	43.4	37.8	37.8	41.5	34.2	34.2	39.4	30.8	30.8	36.4	
			SHC	32.6	38.9	45.3	30.7	37.1	43.4	28.8	35.2	41.5	26.8	33.1	39.4	24.2	30.3	36.4	
		67	TC	48.9	48.9	48.9	45.7	45.7	45.7	42.2	42.2	42.2	38.4	38.4	38.4	34.4	34.4	34.4	
			SHC	26.7	33.0	39.3	24.8	31.2	37.5	22.9	29.3	35.6	20.9	27.3	33.7	18.9	25.2	31.6	
	72	TC	54.2	54.2	54.2	50.7	50.7	50.7	46.9	46.9	46.9	42.9	42.9	42.9	38.6	38.6	38.6		
		SHC	20.7	26.9	33.1	18.8	25.1	31.3	16.9	23.2	29.5	15.0	21.3	27.5	12.9	19.2	25.5		
	76	TC	—	58.4	58.4	—	54.7	54.7	—	50.9	50.9	—	46.6	46.6	—	42.1	42.1		
		SHC	—	21.7	28.3	—	20.0	25.5	—	18.2	24.1	—	16.3	22.3	—	14.3	20.4		
	1400 Cfm	EAT (wb)	58	TC	44.4	44.4	50.4	41.7	41.7	47.5	38.9	38.9	44.4	35.8	35.8	41.0	32.5	32.5	37.4
				SHC	38.4	44.4	50.4	36.0	41.7	47.5	33.4	38.9	44.4	30.6	35.8	41.0	27.7	32.5	37.4
62			TC	45.6	45.6	50.2	42.4	42.4	48.2	39.1	39.1	46.0	36.0	36.0	42.6	32.6	32.6	39.1	
			SHC	35.5	42.9	50.2	33.6	40.9	48.2	31.5	38.7	46.0	28.9	35.8	42.6	26.1	32.6	39.1	
67			TC	50.6	50.6	50.6	47.1	47.1	47.1	43.5	43.5	43.5	39.6	39.6	39.6	35.4	35.4	35.4	
			SHC	28.6	36.0	43.3	26.8	34.1	41.5	24.8	32.2	39.6	22.8	30.2	37.5	20.7	28.1	35.4	
72		TC	55.8	55.8	55.8	52.2	52.2	52.2	48.3	48.3	48.3	44.1	44.1	44.1	39.6	39.6	39.6		
		SHC	21.6	28.8	36.1	19.8	27.0	34.3	17.8	25.1	32.4	15.8	23.1	30.4	13.7	21.0	28.3		
76		TC	—	60.1	60.1	—	56.4	56.4	—	52.4	52.4	—	47.9	47.9	—	43.2	43.2		
		SHC	—	23.0	29.7	—	21.2	28.1	—	19.4	26.4	—	17.4	24.5	—	15.3	22.5		
1600 Cfm		EAT (wb)	58	TC	46.6	46.6	52.9	43.8	43.8	49.8	40.8	40.8	46.5	37.6	37.6	43.0	34.1	34.1	39.2
				SHC	40.4	46.6	52.9	37.8	43.8	49.8	35.1	40.8	46.5	32.2	37.6	43.0	29.1	34.1	39.2
	62		TC	47.4	47.4	53.0	44.3	44.3	50.7	40.9	40.9	48.5	37.7	37.7	44.9	34.2	34.2	40.9	
			SHC	37.4	45.2	53.0	35.3	43.0	50.7	33.3	40.9	48.5	30.4	37.7	44.9	27.4	34.2	40.9	
	67		TC	51.8	51.8	51.8	48.2	48.2	48.2	44.5	44.5	44.5	40.4	40.4	41.3	36.1	36.1	39.1	
			SHC	30.5	38.8	47.2	28.6	36.9	45.3	26.6	35.0	43.3	24.6	32.9	41.3	22.4	30.8	39.1	
	72	TC	57.1	57.1	57.1	53.3	53.3	53.3	49.2	49.2	49.2	44.9	44.9	44.9	40.3	40.3	40.3		
		SHC	22.5	30.7	39.0	20.6	28.8	37.1	18.6	26.9	35.2	16.6	24.9	33.2	14.4	22.7	31.1		
	76	TC	—	61.6	61.6	—	57.7	57.7	—	53.4	53.4	—	48.8	48.8	—	43.9	43.9		
		SHC	—	24.1	32.0	—	22.3	30.2	—	20.3	28.4	—	18.4	26.5	—	16.3	24.4		
	1800 Cfm	EAT (wb)	58	TC	48.5	48.5	55.0	45.6	45.6	51.8	42.5	42.5	48.4	39.1	39.1	44.7	35.4	35.4	40.6
				SHC	42.1	48.5	55.0	39.4	45.6	51.8	36.6	42.5	48.4	33.5	39.1	44.7	30.3	35.4	40.6
62			TC	48.8	48.8	56.6	45.7	45.7	53.9	42.5	42.5	50.4	39.1	39.1	46.6	35.5	35.5	42.4	
			SHC	39.7	48.2	56.6	37.4	45.7	53.9	34.6	42.5	50.4	31.7	39.1	46.6	28.6	35.5	42.4	
67			TC	52.8	52.8	52.8	49.1	49.1	49.1	45.2	45.2	47.0	41.1	41.1	44.9	36.6	36.6	42.6	
			SHC	32.3	41.6	50.9	30.3	39.7	49.0	28.3	37.7	47.0	26.2	35.6	44.9	24.0	33.3	42.6	
72		TC	58.1	58.1	58.1	54.2	54.2	54.2	50.0	50.0	50.0	45.6	45.6	45.6	40.9	40.9	40.9		
		SHC	23.2	32.5	41.7	21.3	30.6	39.8	19.3	28.6	37.9	17.3	26.6	35.9	15.1	24.4	33.8		
76		TC	—	62.7	62.7	—	58.6	58.6	—	54.2	54.2	—	49.6	49.6	—	44.6	44.6		
		SHC	—	25.1	34.0	—	23.2	32.2	—	21.3	30.3	—	19.3	28.4	—	17.2	26.3		
2000 Cfm		EAT (wb)	58	TC	50.2	50.2	56.8	47.1	47.1	53.5	43.9	43.9	49.9	40.4	40.4	46.1	36.6	36.6	41.9
				SHC	43.5	50.2	56.8	40.7	47.1	53.5	37.8	43.9	49.9	34.7	40.4	46.1	31.3	36.6	41.9
	62		TC	50.2	50.2	59.1	47.2	47.2	55.7	43.9	43.9	52.0	40.4	40.4	48.0	36.6	36.6	43.7	
			SHC	41.3	50.2	59.1	38.7	47.2	55.7	35.8	43.9	52.0	32.8	40.4	48.0	29.5	36.6	43.7	
	67		TC	53.6	53.6	54.5	49.8	49.8	52.5	45.9	45.9	50.5	41.6	41.6	48.3	37.1	37.1	45.9	
			SHC	33.9	44.2	54.5	32.0	42.3	52.5	30.0	40.2	50.5	27.8	38.1	48.3	25.5	35.7	45.9	
	72	TC	59.0	59.0	59.0	55.0	55.0	55.0	50.7	50.7	50.7	46.2	46.2	46.2	41.4	41.4	41.4		
		SHC	24.0	34.2	44.4	22.0	32.3	42.5	20.0	30.3	40.5	18.0	28.2	38.5	15.8	26.1	36.3		
	76	TC	—	63.6	63.6	—	59.4	59.4	—	54.9	54.9	—	50.2	50.2	—	45.1	45.1		
		SHC	—	26.0	35.9	—	24.1	34.1	—	22.2	32.2	—	20.2	30.2	—	18.0	28.1		

LEGEND

- Do Not Operate
- Cfm** — Cubic Feet Per Minute (Supply Air)
- EAT (db)** — Entering Air Temperature (dry bulb)
- EAT (wb)** — Entering Air Temperature (wet bulb)
- SHC** — Sensible Heat Capacity (1000 Btuh) Gross
- TC** — Total Capacity (1000 Btuh) Gross

NOTE: See minimum-maximum airflow ratings on page 5.

50GCQM05 LOW STAGE COOLING CAPACITIES

50GCQM05			AMBIENT TEMPERATURE (F)																
			85			95			105			115			125				
			EAT (db)			EAT (db)			EAT (db)			EAT (db)			EAT (db)				
			75	80	85	75	80	85	75	80	85	75	80	85	75	80	85		
1000 Cfm	EAT (wb)	58	TC	29.9	29.9	34.2	27.3	27.3	31.4	24.5	24.5	28.3	21.5	21.5	25.0	18.2	18.2	21.4	
			SHC	25.6	29.9	34.2	23.3	27.3	31.4	20.7	24.5	28.3	18.0	21.5	25.0	15.0	18.2	21.4	
		62	TC	30.7	30.7	34.5	27.6	27.6	32.5	24.6	24.6	29.7	21.5	21.5	26.2	18.2	18.2	22.5	
			SHC	23.8	29.2	34.5	21.8	27.2	32.5	19.5	24.6	29.7	16.8	21.5	26.2	13.9	18.2	22.5	
		67	TC	34.7	34.7	34.7	31.6	31.6	31.6	28.0	28.0	28.0	24.0	24.0	24.0	19.8	19.8	21.7	
			SHC	19.1	24.4	29.7	17.3	22.7	28.0	15.3	20.7	26.0	13.2	18.6	23.9	11.0	16.4	21.7	
	72	TC	38.9	38.9	38.9	35.8	35.8	35.8	32.1	32.1	32.1	28.0	28.0	28.0	23.6	23.6	23.6		
		SHC	14.4	19.5	24.6	12.6	17.9	23.1	10.7	16.0	21.3	8.6	13.9	19.3	6.4	11.8	17.1		
	76	TC	—	42.6	42.6	—	39.4	39.4	—	35.7	35.7	—	31.4	31.4	—	26.8	26.8		
		SHC	—	15.6	20.2	—	14.0	18.8	—	12.2	17.3	—	10.2	15.4	—	8.0	13.3		
	1200 Cfm	EAT (wb)	58	TC	32.4	32.4	37.0	29.7	29.7	34.0	26.7	26.7	30.8	23.5	23.5	27.2	19.9	19.9	23.3
				SHC	27.9	32.4	37.0	25.4	29.7	34.0	22.7	26.7	30.8	19.7	23.5	27.2	16.5	19.9	23.3
62			TC	32.5	32.5	38.6	29.7	29.7	35.5	26.8	26.8	32.2	23.5	23.5	28.5	19.9	19.9	24.5	
			SHC	26.4	32.5	38.6	24.0	29.7	35.5	21.3	26.8	32.2	18.5	23.5	28.5	15.4	19.9	24.5	
67			TC	36.2	36.2	36.2	32.8	32.8	32.8	29.1	29.1	30.0	25.0	25.0	27.9	20.6	20.6	25.5	
			SHC	21.2	27.6	34.0	19.3	25.7	32.1	17.2	23.6	30.0	15.1	21.5	27.9	12.8	19.2	25.5	
72		TC	40.6	40.6	40.6	37.2	37.2	37.2	33.3	33.3	33.3	29.0	29.0	29.0	24.4	24.4	24.4		
		SHC	15.4	21.6	27.8	13.6	19.9	26.3	11.6	17.9	24.3	9.5	15.8	22.2	7.2	13.6	20.0		
76		TC	—	44.5	44.5	—	41.0	41.0	—	36.9	36.9	—	32.5	32.5	—	27.7	27.7		
		SHC	—	16.9	22.8	—	15.2	21.4	—	13.3	19.5	—	11.2	17.5	—	9.1	15.3		
1400 Cfm		EAT (wb)	58	TC	34.5	34.5	39.3	31.6	31.6	36.1	28.5	28.5	32.7	25.0	25.0	29.0	21.3	21.3	24.9
				SHC	29.7	34.5	39.3	27.1	31.6	36.1	24.2	28.5	32.7	21.1	25.0	29.0	17.8	21.3	24.9
	62		TC	34.5	34.5	40.9	31.6	31.6	37.7	28.5	28.5	34.2	25.1	25.1	30.3	21.4	21.4	26.1	
			SHC	28.1	34.5	40.9	25.6	31.6	37.7	22.8	28.5	34.2	19.8	25.1	30.3	16.6	21.4	26.1	
	67		TC	37.3	37.3	37.9	33.7	33.7	36.0	29.9	29.9	33.9	25.7	25.7	31.6	21.5	21.5	28.3	
			SHC	23.1	30.5	37.9	21.1	28.5	36.0	19.1	26.5	33.9	16.8	24.2	31.6	14.2	21.2	28.3	
	72	TC	41.8	41.8	41.8	38.2	38.2	38.2	34.2	34.2	34.2	29.8	29.8	29.8	25.0	25.0	25.0		
		SHC	16.3	23.6	30.9	14.4	21.8	29.1	12.4	19.8	27.1	10.2	17.6	25.0	8.0	15.4	22.8		
	76	TC	—	45.8	45.8	—	42.0	42.0	—	37.8	37.8	—	33.2	33.2	—	28.3	28.3		
		SHC	—	18.1	25.2	—	16.3	23.5	—	14.3	21.5	—	12.2	19.5	—	10.0	17.3		
	1600 Cfm	EAT (wb)	58	TC	36.2	36.2	41.1	33.2	33.2	37.9	29.9	29.9	34.3	26.3	26.3	30.4	22.5	22.5	26.2
				SHC	31.2	36.2	41.1	28.5	33.2	37.9	25.5	29.9	34.3	22.3	26.3	30.4	18.8	22.5	26.2
62			TC	36.2	36.2	42.9	33.2	33.2	39.5	29.9	29.9	35.8	26.4	26.4	31.8	22.5	22.5	27.4	
			SHC	29.6	36.2	42.9	26.9	33.2	39.5	24.1	29.9	35.8	20.9	26.4	31.8	17.6	22.5	27.4	
67			TC	38.1	38.1	41.7	34.5	34.5	39.6	30.5	30.5	37.4	26.5	26.5	34.4	22.6	22.6	29.9	
			SHC	24.9	33.3	41.7	22.9	31.2	39.6	20.7	29.1	37.4	18.2	26.3	34.4	15.2	22.6	29.9	
72		TC	42.7	42.7	42.7	38.9	38.9	38.9	34.8	34.8	34.8	30.3	30.3	30.3	25.4	25.4	25.5		
		SHC	17.1	25.5	33.8	15.2	23.6	31.9	13.1	21.5	29.9	11.0	19.3	27.7	8.7	17.1	25.5		
76		TC	—	46.7	46.7	—	42.8	42.8	—	38.5	38.5	—	33.8	33.8	—	28.8	28.8		
		SHC	—	19.2	27.3	—	17.3	25.4	—	15.2	23.5	—	13.1	21.4	—	10.9	19.2		
1800 Cfm		EAT (wb)	58	TC	37.6	37.6	42.7	34.5	34.5	39.3	31.1	31.1	35.7	27.4	27.4	31.6	23.4	23.4	27.2
				SHC	32.5	37.6	42.7	29.7	34.5	39.3	26.6	31.1	35.7	23.2	27.4	31.6	19.6	23.4	27.2
	62		TC	37.6	37.6	44.5	34.5	34.5	41.0	31.2	31.2	37.2	27.5	27.5	33.0	23.4	23.4	28.5	
			SHC	30.8	37.6	44.5	28.1	34.5	41.0	25.1	31.2	37.2	21.9	27.5	33.0	18.4	23.4	28.5	
	67		TC	38.7	38.7	45.2	35.1	35.1	43.1	31.2	31.2	40.3	27.5	27.5	35.9	23.5	23.5	31.1	
			SHC	26.5	35.9	45.2	24.5	33.8	43.1	22.1	31.2	40.3	19.1	27.5	35.9	15.9	23.5	31.1	
	72	TC	43.3	43.3	43.3	39.5	39.5	39.5	35.3	35.3	35.3	30.7	30.7	30.7	25.8	25.8	28.1		
		SHC	17.9	27.2	36.5	15.9	25.3	34.6	13.9	23.2	32.6	11.7	21.0	30.4	9.4	18.7	28.1		
	76	TC	—	47.3	47.3	—	43.4	43.4	—	39.0	39.0	—	34.3	34.3	—	29.1	29.1		
		SHC	—	20.1	29.2	—	18.2	27.3	—	16.1	25.3	—	14.0	23.2	—	11.8	21.0		

LEGEND

- Do Not Operate
- Cfm** — Cubic Feet Per Minute (Supply Air)
- EAT (db)** — Entering Air Temperature (dry bulb)
- EAT (wb)** — Entering Air Temperature (wet bulb)
- SHC** — Sensible Heat Capacity (1000 Btuh) Gross
- TC** — Total Capacity (1000 Btuh) Gross

NOTE: See minimum-maximum airflow ratings on page 5.



50GCQM06 HIGH STAGE COOLING CAPACITIES

50GCQM06			AMBIENT TEMPERATURE (F)																
			85			95			105			115			125				
			EAT (db)			EAT (db)			EAT (db)			EAT (db)			EAT (db)				
			75	80	85	75	80	85	75	80	85	75	80	85	75	80	85		
1500 Cfm	EAT (wb)	58	TC	54.3	54.3	61.3	51.9	51.9	58.7	49.5	49.5	55.9	46.8	46.8	52.9	43.9	43.9	49.7	
			SHC	47.3	54.3	61.3	45.2	51.9	58.7	43.0	49.5	55.9	40.6	46.8	52.9	38.1	43.9	49.7	
		62	TC	56.6	56.6	59.3	53.7	53.7	57.8	50.5	50.5	56.2	47.2	47.2	54.3	44.0	44.0	51.5	
			SHC	43.2	51.2	59.3	41.7	49.7	57.8	40.1	48.1	56.2	38.3	46.3	54.3	36.1	43.8	51.5	
		67	TC	62.6	62.6	62.6	59.3	59.3	59.3	55.9	55.9	55.9	52.2	52.2	52.2	48.3	48.3	48.3	
			SHC	35.4	43.5	51.5	34.0	42.0	50.0	32.4	40.5	48.5	30.8	38.8	46.9	29.1	37.1	45.2	
	72	TC	68.9	68.9	68.9	65.5	65.5	65.5	61.8	61.8	61.8	57.9	57.9	57.9	53.6	53.6	53.6		
		SHC	27.6	35.5	43.3	26.2	34.1	42.0	24.6	32.5	40.5	23.0	31.0	38.9	21.3	29.3	37.3		
	76	TC	—	74.4	74.4	—	70.8	70.8	—	66.9	66.9	—	62.7	62.7	—	58.1	58.1		
		SHC	—	28.9	37.2	—	27.6	34.7	—	26.1	33.5	—	24.5	32.1	—	22.9	30.6		
	1750 Cfm	EAT (wb)	58	TC	57.5	57.5	64.9	55.0	55.0	62.1	52.3	52.3	59.1	49.4	49.4	55.8	46.2	46.2	52.3
				SHC	50.1	57.5	64.9	47.8	55.0	62.1	45.5	52.3	59.1	42.9	49.4	55.8	40.2	46.2	52.3
62			TC	58.5	58.5	65.4	55.4	55.4	63.7	52.5	52.5	61.0	49.4	49.4	58.1	46.3	46.3	54.4	
			SHC	46.8	56.1	65.4	45.2	54.4	63.7	43.1	52.0	61.0	40.8	49.4	58.1	38.2	46.3	54.4	
67			TC	64.4	64.4	64.4	61.1	61.1	61.1	57.5	57.5	57.5	53.6	53.6	53.6	49.5	49.5	50.0	
			SHC	37.8	47.1	56.4	36.3	45.6	55.0	34.7	44.1	53.4	33.1	42.4	51.8	31.3	40.7	50.0	
72		TC	70.7	70.7	70.7	67.2	67.2	67.2	63.4	63.4	63.4	59.2	59.2	59.2	54.8	54.8	54.8		
		SHC	28.6	37.6	46.7	27.1	36.3	45.4	25.6	34.8	44.0	24.0	33.2	42.4	22.2	31.5	40.7		
76		TC	—	76.3	76.3	—	72.5	72.5	—	68.4	68.4	—	64.0	64.0	—	59.3	59.3		
		SHC	—	30.2	38.7	—	28.8	37.5	—	27.3	36.2	—	25.7	34.7	—	24.1	33.1		
2000 Cfm		EAT (wb)	58	TC	60.1	60.1	67.9	57.5	57.5	64.9	54.6	54.6	61.7	51.5	51.5	58.3	48.2	48.2	54.5
				SHC	52.4	60.1	67.9	50.1	57.5	64.9	47.5	54.6	61.7	44.8	51.5	58.3	41.9	48.2	54.5
	62		TC	60.6	60.6	69.6	57.5	57.5	67.5	54.7	54.7	64.1	51.6	51.6	60.6	48.3	48.3	56.7	
			SHC	49.5	59.5	69.6	47.6	57.5	67.5	45.2	54.7	64.1	42.6	51.6	60.6	39.8	48.3	56.7	
	67		TC	65.7	65.7	65.7	62.3	62.3	62.3	58.6	58.6	58.6	54.7	54.7	56.5	50.4	50.4	54.7	
			SHC	39.9	50.4	60.9	38.5	49.1	59.6	36.9	47.5	58.1	35.3	45.9	56.5	33.5	44.1	54.7	
	72	TC	72.1	72.1	72.1	68.4	68.4	68.4	64.4	64.4	64.4	60.2	60.2	60.2	55.7	55.7	55.7		
		SHC	29.5	39.7	50.0	28.0	38.3	48.6	26.4	36.8	47.1	24.8	35.2	45.6	23.1	33.5	44.0		
	76	TC	—	77.7	77.7	—	73.8	73.8	—	69.6	69.6	—	65.1	65.1	—	60.2	60.2		
		SHC	—	31.4	41.3	—	30.0	40.0	—	28.4	38.6	—	26.8	37.0	—	25.2	35.4		
	2250 Cfm	EAT (wb)	58	TC	62.4	62.4	70.4	59.6	59.6	67.3	56.6	56.6	63.9	53.4	53.4	60.3	49.9	49.9	56.4
				SHC	54.4	62.4	70.4	51.9	59.6	67.3	49.3	56.6	63.9	46.4	53.4	60.3	43.3	49.9	56.4
62			TC	62.5	62.5	73.2	59.7	59.7	69.9	56.7	56.7	66.5	53.4	53.4	62.7	49.9	49.9	58.6	
			SHC	51.8	62.5	73.2	49.4	59.7	69.9	46.9	56.7	66.5	44.1	53.4	62.7	41.2	49.9	58.6	
67			TC	66.7	66.7	66.7	63.3	63.3	64.2	59.5	59.5	62.6	55.5	55.5	61.0	51.1	51.1	59.2	
			SHC	41.8	53.4	65.0	40.6	52.4	64.2	39.0	50.8	62.6	37.3	49.2	61.0	35.5	47.4	59.2	
72		TC	73.2	73.2	73.2	69.4	69.4	69.4	65.4	65.4	65.4	61.0	61.0	61.0	56.4	56.4	56.4		
		SHC	30.3	41.7	53.1	28.8	40.3	51.8	27.3	38.8	50.4	25.6	37.2	48.9	23.9	35.6	47.2		
76		TC	—	78.9	78.9	—	74.8	74.8	—	70.5	70.5	—	65.9	65.9	—	61.0	61.0		
		SHC	—	32.4	43.6	—	31.0	42.2	—	29.5	40.8	—	27.9	39.2	—	26.2	37.6		
2500 Cfm		EAT (wb)	58	TC	64.4	64.4	72.6	61.4	61.4	69.4	58.3	58.3	65.8	54.9	54.9	62.1	51.3	51.3	58.0
				SHC	56.1	64.4	72.6	53.5	61.4	69.4	50.7	58.3	65.8	47.8	54.9	62.1	44.6	51.3	58.0
	62		TC	64.4	64.4	75.5	61.5	61.5	72.1	58.4	58.4	68.4	55.0	55.0	64.5	51.3	51.3	60.3	
			SHC	53.4	64.4	75.5	50.9	61.5	72.1	48.3	58.4	68.4	45.4	55.0	64.5	42.4	51.3	60.3	
	67		TC	67.7	67.7	69.7	64.2	64.2	68.5	60.3	60.3	67.0	56.2	56.2	65.4	51.8	51.8	63.4	
			SHC	44.0	56.9	69.7	42.6	55.5	68.5	41.0	54.0	67.0	39.3	52.4	65.4	37.4	50.4	63.4	
	72	TC	74.2	74.2	74.2	70.3	70.3	70.3	66.1	66.1	66.1	61.7	61.7	61.7	57.0	57.0	57.0		
		SHC	31.1	43.7	56.3	29.6	42.3	55.0	28.1	40.8	53.6	26.4	39.2	52.0	24.7	37.5	50.4		
	76	TC	—	79.8	79.8	—	75.7	75.7	—	71.3	71.3	—	66.6	66.6	—	61.6	61.6		
		SHC	—	33.5	45.8	—	32.1	44.4	—	30.5	43.0	—	28.9	41.4	—	27.2	39.8		

LEGEND

- Do Not Operate
- Cfm** — Cubic Feet Per Minute (Supply Air)
- EAT (db)** — Entering Air Temperature (dry bulb)
- EAT (wb)** — Entering Air Temperature (wet bulb)
- SHC** — Sensible Heat Capacity (1000 Btuh) Gross
- TC** — Total Capacity (1000 Btuh) Gross

NOTE: See minimum-maximum airflow ratings on page 5.



50GCQM06 LOW STAGE COOLING CAPACITIES

50GCQM06			AMBIENT TEMPERATURE (F)																
			85			95			105			115			125				
			EAT (db)			EAT (db)			EAT (db)			EAT (db)			EAT (db)				
			75	80	85	75	80	85	75	80	85	75	80	85	75	80	85		
1250 Cfm	EAT (wb)	58	TC	38.8	38.8	44.0	36.3	36.3	41.3	33.7	33.7	38.5	30.9	30.9	35.4	27.8	27.8	32.0	
			SHC	33.5	38.8	44.0	31.3	36.3	41.3	28.9	33.7	38.5	26.4	30.9	35.4	23.6	27.8	32.0	
		62	TC	39.4	39.4	44.9	36.5	36.5	42.9	33.8	33.8	40.1	30.9	30.9	36.9	27.9	27.9	33.4	
			SHC	31.4	38.1	44.9	29.6	36.3	42.9	27.4	33.8	40.1	24.9	30.9	36.9	22.3	27.9	33.4	
		67	TC	44.3	44.3	44.3	41.1	41.1	41.1	37.7	37.7	37.7	34.0	34.0	34.0	30.0	30.0	31.6	
			SHC	25.4	32.1	38.9	23.7	30.5	37.2	21.9	28.7	35.4	20.1	26.8	33.6	18.1	24.9	31.6	
	72	TC	49.4	49.4	49.4	46.2	46.2	46.2	42.6	42.6	42.6	38.7	38.7	38.7	34.5	34.5	34.5		
		SHC	19.2	25.8	32.4	17.5	24.2	30.9	15.8	22.5	29.2	14.0	20.7	27.4	12.1	18.8	25.5		
	76	TC	—	53.9	53.9	—	50.5	50.5	—	46.7	46.7	—	42.7	42.7	—	38.3	38.3		
		SHC	—	20.7	26.9	—	19.1	25.5	—	17.4	23.9	—	15.6	22.2	—	13.8	20.4		
	1500 Cfm	EAT (wb)	58	TC	41.7	41.7	47.3	39.1	39.1	44.4	36.3	36.3	41.4	33.3	33.3	38.0	30.0	30.0	34.4
				SHC	36.1	41.7	47.3	33.8	39.1	44.4	31.2	36.3	41.4	28.5	33.3	38.0	25.6	30.0	34.4
62			TC	41.8	41.8	49.3	39.2	39.2	46.3	36.3	36.3	43.1	33.3	33.3	39.7	30.0	30.0	35.9	
			SHC	34.3	41.8	49.3	32.0	39.2	46.3	29.6	36.3	43.1	26.9	33.3	39.7	24.1	30.0	35.9	
67			TC	45.9	45.9	45.9	42.5	42.5	42.5	39.0	39.0	40.4	35.1	35.1	38.5	31.0	31.0	36.5	
			SHC	27.9	35.9	43.9	26.1	34.2	42.2	24.3	32.4	40.4	22.4	30.5	38.5	20.4	28.5	36.5	
72		TC	51.0	51.0	51.0	47.5	47.5	47.5	43.8	43.8	43.8	39.8	39.8	39.8	35.5	35.5	35.5		
		SHC	20.2	28.1	35.9	18.6	26.5	34.4	16.8	24.8	32.7	15.0	23.0	31.0	13.0	21.1	29.1		
76		TC	—	55.4	55.4	—	51.8	51.8	—	47.9	47.9	—	43.7	43.7	—	39.2	39.2		
		SHC	—	21.9	29.5	—	20.3	28.0	—	18.6	26.3	—	16.8	24.6	—	15.0	22.8		
1750 Cfm		EAT (wb)	58	TC	44.1	44.1	50.0	41.4	41.4	47.0	38.4	38.4	43.7	35.2	35.2	40.2	31.7	31.7	36.3
				SHC	38.2	44.1	50.0	35.8	41.4	47.0	33.1	38.4	43.7	30.2	35.2	40.2	27.1	31.7	36.3
	62		TC	44.2	44.2	52.0	41.4	41.4	48.9	38.4	38.4	45.5	35.2	35.2	41.9	31.8	31.8	37.9	
			SHC	36.3	44.2	52.0	33.9	41.4	48.9	31.3	38.4	45.5	28.6	35.2	41.9	25.6	31.8	37.9	
	67		TC	47.0	47.0	48.8	43.6	43.6	47.1	39.9	39.9	45.2	36.0	36.0	43.2	31.9	31.9	40.9	
			SHC	30.2	39.5	48.8	28.4	37.7	47.1	26.6	35.9	45.2	24.6	33.9	43.2	22.5	31.7	40.9	
	72	TC	52.1	52.1	52.1	48.5	48.5	48.5	44.7	44.7	44.7	40.6	40.6	40.6	36.2	36.2	36.2		
		SHC	21.2	30.2	39.2	19.5	28.6	37.7	17.7	26.9	36.0	15.9	25.1	34.3	13.9	23.2	32.5		
	76	TC	—	56.6	56.6	—	52.8	52.8	—	48.8	48.8	—	44.5	44.5	—	39.9	39.9		
		SHC	—	23.1	31.9	—	21.5	30.3	—	19.7	28.7	—	17.9	26.9	—	16.0	25.1		
	2000 Cfm	EAT (wb)	58	TC	46.1	46.1	52.2	43.2	43.2	49.0	40.1	40.1	45.6	36.7	36.7	41.9	33.1	33.1	37.9
				SHC	40.0	46.1	52.2	37.4	43.2	49.0	34.6	40.1	45.6	31.6	36.7	41.9	28.3	33.1	37.9
62			TC	46.1	46.1	54.2	43.3	43.3	51.0	40.1	40.1	47.5	36.8	36.8	43.7	33.2	33.2	39.6	
			SHC	38.0	46.1	54.2	35.5	43.3	51.0	32.8	40.1	47.5	29.9	36.8	43.7	26.8	33.2	39.6	
67			TC	47.9	47.9	53.5	44.4	44.4	51.7	40.7	40.7	49.7	36.8	36.8	47.2	32.4	32.4	42.7	
			SHC	32.3	42.9	53.5	30.5	41.1	51.7	28.7	39.2	49.7	26.5	36.8	47.2	22.1	32.4	42.7	
72		TC	53.0	53.0	53.0	49.3	49.3	49.3	45.4	45.4	45.4	41.2	41.2	41.2	36.7	36.7	36.7		
		SHC	22.1	32.3	42.5	20.3	30.6	40.9	18.6	28.9	39.3	16.7	27.1	37.6	14.8	25.3	35.7		
76		TC	—	57.4	57.4	—	53.6	53.6	—	49.5	49.5	—	45.1	45.1	—	40.4	40.4		
		SHC	—	24.2	34.1	—	22.5	32.5	—	20.8	30.8	—	19.0	29.1	—	17.1	27.3		
2250 Cfm		EAT (wb)	58	TC	47.8	47.8	54.0	44.8	44.8	50.7	41.5	41.5	47.2	38.1	38.1	43.4	34.3	34.3	39.2
				SHC	41.5	47.8	54.0	38.8	44.8	50.7	35.9	41.5	47.2	32.7	38.1	43.4	29.4	34.3	39.2
	62		TC	47.8	47.8	56.2	44.8	44.8	52.8	41.6	41.6	49.1	38.1	38.1	45.2	34.3	34.3	40.9	
			SHC	39.4	47.8	56.2	36.8	44.8	52.8	34.0	41.6	49.1	31.0	38.1	45.2	27.8	34.3	40.9	
	67		TC	48.7	48.7	57.9	45.2	45.2	56.0	41.7	41.7	52.9	37.6	37.6	48.8	34.4	34.4	44.2	
			SHC	34.4	46.1	57.9	32.5	44.3	56.0	30.2	41.6	52.9	26.4	37.6	48.8	24.5	34.4	44.2	
	72	TC	53.7	53.7	53.7	50.0	50.0	50.0	46.0	46.0	46.0	41.7	41.7	41.7	37.1	37.1	38.9		
		SHC	22.9	34.2	45.6	21.2	32.6	44.1	19.4	30.9	42.5	17.5	29.1	40.7	15.6	27.2	38.9		
	76	TC	—	58.1	58.1	—	54.2	54.2	—	50.0	50.0	—	45.6	45.6	—	40.8	40.8		
		SHC	—	25.2	36.1	—	23.5	34.6	—	21.8	33.0	—	20.0	31.3	—	18.1	29.5		

LEGEND

- Do Not Operate
- Cfm** — Cubic Feet Per Minute (Supply Air)
- EAT (db)** — Entering Air Temperature (dry bulb)
- EAT (wb)** — Entering Air Temperature (wet bulb)
- SHC** — Sensible Heat Capacity (1000 Btuh) Gross
- TC** — Total Capacity (1000 Btuh) Gross

NOTE: See minimum-maximum airflow ratings on page 5.



50GCQM04 HEATING CAPACITIES

50GCQM04 (3 Tons)											
Return Air (°F db)	CFM (Standard Air)		Temperature Air Entering Outdoor Coil (°F db at 70% rh)								
			-10	0	10	17	30	40	47	50	60
55	900	Capacity	9.6	13.1	16.9	19.8	25.8	31.0	35.4	36.7	42.5
		Int. Cap.	8.9	12.0	15.5	18.0	22.6	31.0	35.4	36.7	42.5
	1200	Capacity	10.0	13.6	17.6	20.5	26.7	32.6	36.7	38.0	43.9
		Int. Cap.	9.2	12.5	16.1	18.7	23.4	32.6	36.7	38.0	43.9
	1500	Capacity	10.7	14.4	18.4	21.5	27.9	33.7	37.8	39.1	44.8
		Int. Cap.	9.9	13.2	16.9	19.6	24.5	33.7	37.8	39.1	44.8
70	900	Capacity	7.3	10.8	14.6	17.5	23.3	28.3	32.4	34.0	40.1
		Int. Cap.	6.7	9.9	13.4	16.0	20.4	28.3	32.4	34.0	40.1
	1200	Capacity	7.7	11.3	15.3	18.3	24.4	29.6	34.3	35.7	41.6
		Int. Cap.	7.1	10.4	14.1	16.7	21.4	29.6	34.3	35.7	41.6
	1500	Capacity	8.4	12.2	16.3	19.3	25.6	31.1	35.7	37.1	42.8
		Int. Cap.	7.8	11.2	14.9	17.6	22.4	31.1	35.7	37.1	42.8
80	900	Capacity	5.4	9.0	12.9	15.8	21.6	26.5	30.3	31.8	38.2
		Int. Cap.	5.0	8.3	11.9	14.4	19.0	26.5	30.3	31.8	38.2
	1200	Capacity	5.8	9.6	13.6	16.6	22.7	27.8	32.1	33.7	40.0
		Int. Cap.	5.4	8.8	12.5	15.2	19.8	27.8	32.1	33.7	40.0
	1500	Capacity	6.6	10.4	14.5	17.6	23.8	29.1	33.7	35.4	41.3
		Int. Cap.	6.1	9.6	13.3	16.1	20.9	29.1	33.7	35.4	41.3

LEGEND

Capacity — Instantaneous Capacity (1000 Btuh) - includes indoor fan motor heat at AHRI static conditions

Int. Cap. — Integrated Capacity = instantaneous capacity minus the effects of frost on the OD coil and the heat required to defrost it

rh — Relative Humidity

db — Dry Bulb

50GCQM05 HEATING CAPACITIES

		50GCQM05 (4 Tons)									
Return Air (°F db)	CFM (Standard Air)	Temperature Air Entering Outdoor Coil (°F db at 70% rh)									
		-10	0	10	17	30	40	47	50	60	
55	900	Capacity	12.8	18.0	23.3	27.2	34.8	41.4	47.1	48.8	56.0
		Int. Cap.	11.8	16.6	21.4	24.8	30.5	41.4	47.1	48.8	56.0
	1200	Capacity	12.9	18.3	23.8	27.9	35.6	43.1	48.2	49.9	56.9
		Int. Cap.	12.0	16.9	21.8	25.4	31.2	43.1	48.2	49.9	56.9
	1500	Capacity	13.8	19.3	24.8	29.2	37.0	44.4	49.3	50.9	57.5
		Int. Cap.	12.8	17.8	22.8	26.6	32.4	44.4	49.3	50.9	57.5
70	900	Capacity	10.4	15.7	20.9	24.7	32.3	38.4	43.5	45.5	53.5
		Int. Cap.	9.6	14.4	19.2	22.5	28.3	38.4	43.5	45.5	53.5
	1200	Capacity	10.7	16.1	21.5	25.4	33.5	39.5	45.6	47.5	54.7
		Int. Cap.	9.9	14.8	19.8	23.1	29.3	39.5	45.6	47.5	54.7
	1500	Capacity	11.6	17.2	22.7	26.6	34.7	41.3	47.2	48.9	55.7
		Int. Cap.	10.7	15.8	20.8	24.2	30.4	41.3	47.2	48.9	55.7
80	900	Capacity	8.4	13.8	19.1	22.8	30.3	36.9	41.3	43.1	51.3
		Int. Cap.	7.8	12.7	17.5	20.8	26.6	36.9	41.3	43.1	51.3
	1200	Capacity	8.7	14.2	19.7	23.6	31.4	37.9	42.9	45.0	53.0
		Int. Cap.	8.0	13.1	18.1	21.5	27.5	37.9	42.9	45.0	53.0
	1500	Capacity	9.6	15.3	20.9	24.8	32.9	39.3	44.9	46.9	54.2
		Int. Cap.	8.9	14.1	19.2	22.6	28.8	39.3	44.9	46.9	54.2

LEGEND

Capacity — Instantaneous Capacity (1000 Btuh) - includes indoor fan motor heat at AHRI static conditions

Int. Cap. — Integrated Capacity = instantaneous capacity minus the effects of frost on the OD coil and the heat required to defrost it

rh — Relative Humidity

db — Dry Bulb

50GCQM06 HEATING CAPACITIES

		50GCQM05 (5 Tons)									
Return Air (°F db)	CFM (Standard Air)	Temperature Air Entering Outdoor Coil (°F db at 70% rh)									
		-10	0	10	17	30	40	47	50	60	
55	900	Capacity	14.5	20.5	27.0	31.8	42.0	49.9	56.5	58.6	67.1
		Int. Cap.	13.4	18.9	24.8	29.0	36.8	49.9	56.5	58.6	67.1
	1200	Capacity	16.2	22.4	29.0	34.0	44.2	52.6	58.9	60.8	68.4
		Int. Cap.	14.9	20.6	26.6	31.0	38.8	52.6	58.9	60.8	68.4
	1500	Capacity	17.2	23.5	30.2	35.4	45.6	53.7	59.2	60.8	67.3
		Int. Cap.	15.9	21.6	27.7	32.3	40.0	53.7	59.2	60.8	67.3
70	900	Capacity	11.2	17.4	23.8	28.6	38.6	46.9	53.3	55.3	63.9
		Int. Cap.	10.4	16.0	21.9	26.1	33.9	46.9	53.3	55.3	63.9
	1200	Capacity	12.9	19.2	25.9	30.8	41.5	49.4	55.9	57.8	65.9
		Int. Cap.	11.9	17.7	23.7	28.1	36.4	49.4	55.9	57.8	65.9
	1500	Capacity	13.9	20.4	27.1	32.1	42.9	51.0	57.0	58.8	65.8
		Int. Cap.	12.9	18.7	24.9	29.3	37.6	51.0	57.0	58.8	65.8
80	900	Capacity	8.8	15.0	21.6	26.3	35.9	44.7	50.9	53.2	61.7
		Int. Cap.	8.1	13.8	19.8	24.0	31.5	44.7	50.9	53.2	61.7
	1200	Capacity	10.5	16.9	23.6	28.5	38.6	47.4	53.7	55.9	63.9
		Int. Cap.	9.7	15.5	21.7	26.0	33.8	47.4	53.7	55.9	63.9
	1500	Capacity	11.5	18.0	24.8	29.9	40.4	49.0	55.1	56.9	64.2
		Int. Cap.	10.6	16.6	22.8	27.2	35.4	49.0	55.1	56.9	64.2

LEGEND

- Indicates operation not permissible
- Capacity** — Instantaneous Capacity (1000 Btuh) - includes indoor fan motor heat at AHRI static conditions
- Int. Cap.** — Integrated Capacity = instantaneous capacity minus the effects of frost on the OD coil and the heat required to defrost it
- rh** — Relative Humidity
- db** — Dry Bulb

PRESSURE DROPS FOR ELECTRIC HEATING UNITS

PRESSURE DROP FOR ELECTRIC HEAT 3 TON UNITS - 1 STAGE HEAT

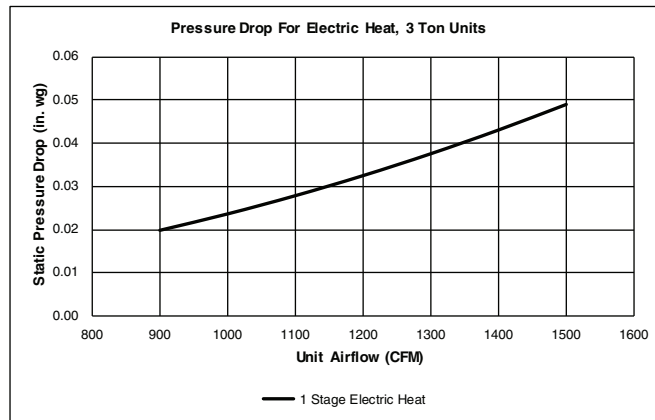

PRESSURE DROP FOR ELECTRIC HEAT 4 AND 5 TON UNITS - 1 AND 2 STAGE HEAT

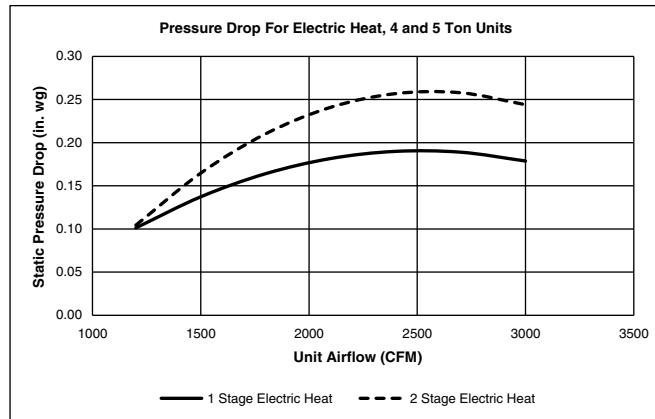



FIELD-INSTALLED ACCESSORY ELECTRIC HEATER DATA

50GCQ UNIT SIZE	VOLTAGE	HEATER MODEL NUMBER*	NUMBER OF STAGES
04	208/230	CRHEATER323A00	1
		CRHEATER324A00	1
		CRHEATER325A00	1
		CRHEATER326A00	1
		CRHEATER327A00	2
		CRHEATER328A00	1
	460	CRHEATER333A00	1
		CRHEATER334A00	1
		CRHEATER335A00	1
		CRHEATER336A00	1
	575	CRHEATER339A00	1
		CRHEATER340A00	1
05	208/230	CRHEATER323A00	1
		CRHEATER324A00	1
		CRHEATER325A00	1
		CRHEATER326A00	1
		CRHEATER327A00	2
		CRHEATER328A00	1
		CRHEATER329A00	2
		CRHEATER330A00†	2
		CRHEATER331A00**	2
		460	CRHEATER333A00
	CRHEATER335A00		1
	CRHEATER336A00		1
	CRHEATER337A00		2
	575	CRHEATER339A00	1
		CRHEATER340A00	1
	06	208/230	CRHEATER324A00
CRHEATER325A00			1
CRHEATER326A00			1
CRHEATER327A00			2
CRHEATER328A00			1
CRHEATER329A00			2
CRHEATER331A00			2
CRHEATER332A00			2
460		CRHEATER333A00	1
		CRHEATER335A00	1
		CRHEATER336A00	1
		CRHEATER337A00	2
575		CRHEATER338A00	2
		CRHEATER340A00	1
		CRHEATER341A00	2

*Check heater nameplate for model number.

†Do not use with size 05 horizontal supply duct configuration units.

**Do not use with size 05 vertical supply duct configuration units.

USE OF CRHEATER330A00 FOR 50GCQ UNITS (WITH OR WITHOUT NON-FUSED DISCONNECT)

DUCT CONFIGURATION	50GCQ UNIT SIZE		
	04	05	06
Vertical Supply	Not available	Available	Not available
Horizontal Supply	Not available	Not available	Not available

USE OF CRHEATER331A00 FOR 50GCQ UNITS (WITH OR WITHOUT NON-FUSED DISCONNECT)

DUCT CONFIGURATION	50GCQ UNIT SIZE		
	04	05	06
Vertical Supply	Not available	Not available	Available
Horizontal Supply	Not available	Available	Available

ECONOMIZER BAROMETRIC RELIEF AND STATIC PRESSURE

Horizontal Economizer Barometric Relief

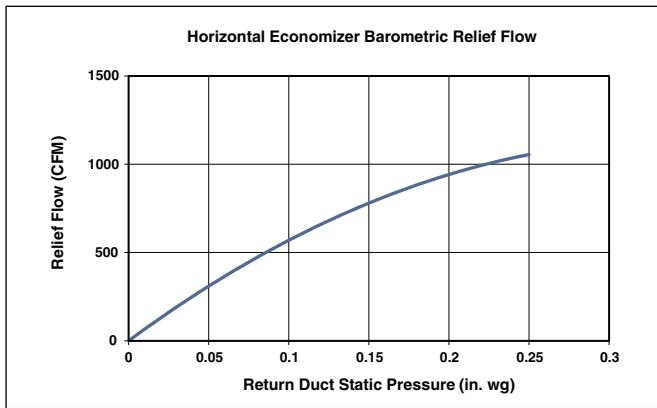

Vertical Economizer Barometric Relief

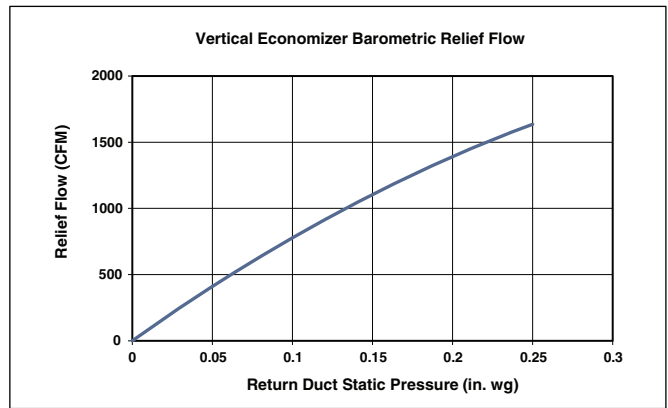

Horizontal Economizer Damper Leakage

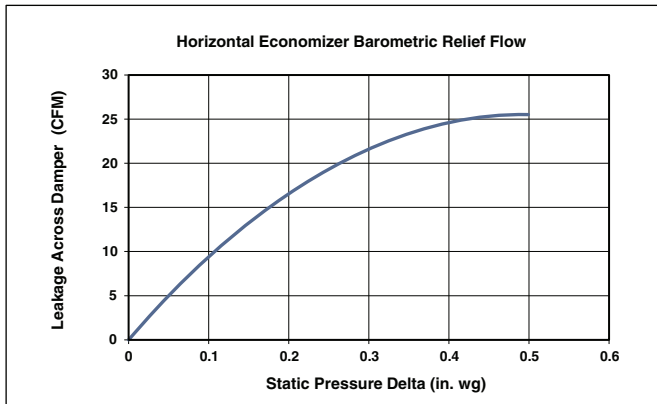

Vertical Economizer Damper Leakage

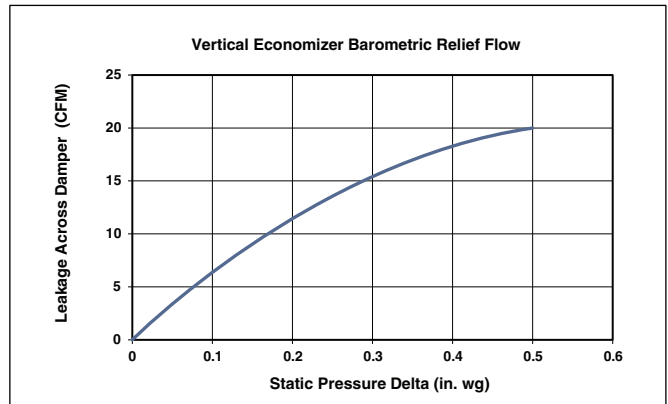

MERV-8 filters pressure drop

NOTE: For factory-installed MERV-8 filters, no additional pressure drop adjustments are necessary. The standard fan tables accommodate usage.

GENERAL FAN PERFORMANCE NOTES

1. Interpolation is permissible. Do not extrapolate.
2. External static pressure is the static pressure difference between the return duct and the supply duct plus the static pressure caused by any FIOPs or accessories.
3. Tabular data accounts for pressure loss due to clean filters, unit casing, and wet coils.
4. Factory options and accessories may effect static pressure losses. Selection software is available, through your salesperson, to help you select the best motor/drive combination for your application.
5. The fan performance tables offer motor/drive recommendations. In cases when two motor/drive combinations would work, Carrier recommends the lower horsepower option.
6. For information on the electrical properties of Carrier motors, please see the Electrical Data section of this book.
7. For more information on the performance limits of Carrier motors, see the application data section of this book.
8. The EPACT (Energy Policy Act of 1992) regulates energy requirements for specific types of indoor fan motors. Motors regulated by EPACT include any general purpose, T-frame (three-digit, 143 and larger), single-speed, foot mounted, polyphase, squirrel cage induction motors of NEMA (National Electrical Manufacturers Association) design A and B, manufactured for use in the United States. Ranging from 1 to 200 Hp, these continuous-duty motors operate on 230 and 460 volt, 60 Hz power. If a motor does not fit into these specifications, the motor does not have to be replaced by an EPACT compliant energy-efficient motor. Variable-speed motors are exempt from EPACT compliance requirements.

50GQM04 SINGLE PHASE — 3 TON VERTICAL SUPPLY (RPM - BHP)

CFM	AVAILABLE EXTERNAL STATIC PRESSURE (in. wg)									
	0.2		0.4		0.6		0.8		1.0	
	RPM	BHP	RPM	BHP	RPM	BHP	RPM	BHP	RPM	BHP
900	1059	0.08	1325	0.16	1541	0.25	1718	0.35	1870	0.46
975	1102	0.09	1356	0.17	1572	0.27	1751	0.37	1906	0.48
1050	1149	0.11	1388	0.19	1602	0.29	1783	0.39	1940	0.51
1125	1198	0.12	1422	0.20	1632	0.30	1814	0.42	1973	0.53
1200	1250	0.14	1459	0.22	1662	0.32	1844	0.44	2005	0.56
1275	1303	0.15	1499	0.23	1695	0.34	1874	0.46	2035	0.59
1350	1357	0.17	1542	0.26	1728	0.36	1905	0.48	2065	0.61
1425	1413	0.20	1587	0.28	1764	0.38	1936	0.51	2095	0.64
1500	1469	0.22	1635	0.30	1803	0.41	1969	0.53	2126	0.67

CFM	AVAILABLE EXTERNAL STATIC PRESSURE (in. wg)									
	1.2		1.4		1.6		1.8		2.0	
	RPM	BHP	RPM	BHP	RPM	BHP	RPM	BHP	RPM	BHP
900	2006	0.56	2129	0.67	2244	0.79	2352	0.91	2453	1.03
975	2043	0.59	2168	0.71	2283	0.83	2391	0.95	—	—
1050	2079	0.63	2205	0.75	2322	0.87	2430	1.00	—	—
1125	2114	0.66	2242	0.78	2359	0.91	2468	1.05	—	—
1200	2147	0.69	2277	0.82	2395	0.96	—	—	—	—
1275	2180	0.72	2310	0.86	2430	1.00	—	—	—	—
1350	2211	0.75	2343	0.90	2464	1.04	—	—	—	—
1425	2241	0.78	2374	0.93	—	—	—	—	—	—
1500	2271	0.82	2405	0.97	—	—	—	—	—	—

Standard Static 1059-1890 RPM, 0.44 Max BHP

Medium Static 1059-2190 RPM, 0.71 Max BHP

High Static 1059-2490 RPM, 1.07 Max BHP

50GQM04 SINGLE PHASE - STANDARD STATIC — 3 TON VERTICAL SUPPLY (RPM - VDC)

CFM	AVAILABLE EXTERNAL STATIC PRESSURE (in. wg)									
	0.2		0.4		0.6		0.8		1.0	
	RPM	Vdc	RPM	Vdc	RPM	Vdc	RPM	Vdc	RPM	Vdc
900	1060	5.6	1325	7.0	1541	8.2	1718	9.1	1871	9.9
975	1103	5.8	1355	7.2	1572	8.3	1752	9.3	—	—
1050	1150	6.1	1387	7.3	1602	8.5	1784	9.4	—	—
1125	1198	6.3	1422	7.5	1632	8.6	1815	9.6	—	—
1200	1249	6.6	1459	7.7	1662	8.8	1845	9.8	—	—
1275	1303	6.9	1499	7.9	1694	9.0	1874	9.9	—	—
1350	1357	7.2	1542	8.2	1728	9.1	—	—	—	—
1425	1413	7.5	1587	8.4	1765	9.3	—	—	—	—
1500	1469	7.8	1635	8.7	1803	9.5	—	—	—	—

CFM	AVAILABLE EXTERNAL STATIC PRESSURE (in. wg)									
	1.2		1.4		1.6		1.8		2.0	
	RPM	Vdc	RPM	Vdc	RPM	Vdc	RPM	Vdc	RPM	Vdc
900	—	—	—	—	—	—	—	—	—	—
975	—	—	—	—	—	—	—	—	—	—
1050	—	—	—	—	—	—	—	—	—	—
1125	—	—	—	—	—	—	—	—	—	—
1200	—	—	—	—	—	—	—	—	—	—
1275	—	—	—	—	—	—	—	—	—	—
1350	—	—	—	—	—	—	—	—	—	—
1425	—	—	—	—	—	—	—	—	—	—
1500	—	—	—	—	—	—	—	—	—	—

Standard Static 1060-1890 RPM



50GCQM04 SINGLE PHASE - MEDIUM STATIC — 3 TON VERTICAL SUPPLY (RPM - VDC)

CFM	AVAILABLE EXTERNAL STATIC PRESSURE (in. wg)									
	0.2		0.4		0.6		0.8		1.0	
	RPM	Vdc	RPM	Vdc	RPM	Vdc	RPM	Vdc	RPM	Vdc
900	1060	4.8	1325	6.1	1541	7.0	1718	7.8	1871	8.5
975	1103	5.0	1355	6.2	1572	7.2	1752	8.0	1906	8.7
1050	1150	5.3	1387	6.3	1602	7.3	1784	8.1	1941	8.9
1125	1198	5.5	1422	6.5	1632	7.5	1815	8.3	1974	9.0
1200	1249	5.7	1459	6.7	1662	7.6	1845	8.4	2005	9.2
1275	1303	5.9	1499	6.8	1694	7.7	1874	8.6	2036	9.3
1350	1357	6.2	1542	7.0	1728	7.9	1905	8.7	2066	9.4
1425	1413	6.5	1587	7.2	1765	8.1	1936	8.8	2095	9.6
1500	1469	6.7	1635	7.5	1803	8.2	1969	9.0	2126	9.7

CFM	AVAILABLE EXTERNAL STATIC PRESSURE (in. wg)									
	1.2		1.4		1.6		1.8		2.0	
	RPM	Vdc	RPM	Vdc	RPM	Vdc	RPM	Vdc	RPM	Vdc
900	2006	9.2	2130	9.7	—	—	—	—	—	—
975	2044	9.3	2168	9.9	—	—	—	—	—	—
1050	2080	9.5	—	—	—	—	—	—	—	—
1125	2115	9.7	—	—	—	—	—	—	—	—
1200	2148	9.8	—	—	—	—	—	—	—	—
1275	2180	10.0	—	—	—	—	—	—	—	—
1350	—	—	—	—	—	—	—	—	—	—
1425	—	—	—	—	—	—	—	—	—	—
1500	—	—	—	—	—	—	—	—	—	—

Medium Static 1060-2190 RPM

50GCQM04 SINGLE PHASE - HIGH STATIC — 3 TON VERTICAL SUPPLY (RPM - VDC)

CFM	AVAILABLE EXTERNAL STATIC PRESSURE (in. wg)									
	0.2		0.4		0.6		0.8		1.0	
	RPM	Vdc	RPM	Vdc	RPM	Vdc	RPM	Vdc	RPM	Vdc
900	1060	4.3	1325	5.3	1541	6.2	1718	6.9	1871	7.5
975	1103	4.4	1355	5.4	1572	6.3	1752	7.0	1906	7.7
1050	1150	4.6	1387	5.6	1602	6.4	1784	7.2	1941	7.8
1125	1198	4.8	1422	5.7	1632	6.6	1815	7.3	1974	7.9
1200	1249	5.0	1459	5.9	1662	6.7	1845	7.4	2005	8.1
1275	1303	5.2	1499	6.0	1694	6.8	1874	7.5	2036	8.2
1350	1357	5.4	1542	6.2	1728	6.9	1905	7.7	2066	8.3
1425	1413	5.7	1587	6.4	1765	7.1	1936	7.8	2095	8.4
1500	1469	5.9	1635	6.6	1803	7.2	1969	7.9	2126	8.5

CFM	AVAILABLE EXTERNAL STATIC PRESSURE (in. wg)									
	1.2		1.4		1.6		1.8		2.0	
	RPM	Vdc	RPM	Vdc	RPM	Vdc	RPM	Vdc	RPM	Vdc
900	2006	8.1	2130	8.6	2244	9.0	2352	9.4	2453	9.9
975	2044	8.2	2168	8.7	2283	9.2	2391	9.6	—	—
1050	2080	8.4	2206	8.9	2322	9.3	2430	9.8	—	—
1125	2115	8.5	2242	9.0	2359	9.5	2468	9.9	—	—
1200	2148	8.6	2277	9.1	2396	9.6	—	—	—	—
1275	2180	8.8	2311	9.3	2431	9.8	—	—	—	—
1350	2211	8.9	2343	9.4	2465	9.9	—	—	—	—
1425	2241	9.0	2375	9.5	—	—	—	—	—	—
1500	2271	9.1	2405	9.7	—	—	—	—	—	—

High Static 1060-2490 RPM

50GCQM04 THREE PHASE — 3 TON VERTICAL SUPPLY (RPM - BHP)

CFM	AVAILABLE EXTERNAL STATIC PRESSURE (in. wg)									
	0.2		0.4		0.6		0.8		1.0	
	RPM	BHP	RPM	BHP	RPM	BHP	RPM	BHP	RPM	BHP
900	1058	0.08	1325	0.16	1541	0.25	1718	0.35	1870	0.46
975	1102	0.09	1356	0.17	1572	0.27	1751	0.37	1906	0.48
1050	1149	0.11	1388	0.19	1602	0.29	1783	0.39	1940	0.51
1125	1198	0.12	1422	0.20	1632	0.30	1814	0.42	1973	0.53
1200	1250	0.14	1459	0.22	1662	0.32	1844	0.44	2005	0.56
1275	1303	0.15	1499	0.23	1695	0.34	1874	0.46	2035	0.59
1350	1357	0.17	1542	0.26	1728	0.36	1905	0.48	2065	0.61
1425	1413	0.20	1587	0.28	1764	0.38	1936	0.51	2095	0.64
1500	1469	0.22	1635	0.30	1803	0.41	1969	0.53	2126	0.67

CFM	AVAILABLE EXTERNAL STATIC PRESSURE (in. wg)									
	1.2		1.4		1.6		1.8		2.0	
	RPM	BHP	RPM	BHP	RPM	BHP	RPM	BHP	RPM	BHP
900	2006	0.56	2129	0.67	2244	0.79	2352	0.91	2453	1.03
975	2043	0.59	2168	0.71	2283	0.83	2391	0.95	—	—
1050	2079	0.63	2205	0.75	2322	0.87	2430	1.00	—	—
1125	2114	0.66	2242	0.78	2359	0.91	2468	1.05	—	—
1200	2147	0.69	2277	0.82	2395	0.96	—	—	—	—
1275	2180	0.72	2310	0.86	2430	1.00	—	—	—	—
1350	2211	0.75	2343	0.90	2464	1.04	—	—	—	—
1425	2241	0.78	2374	0.93	—	—	—	—	—	—
1500	2271	0.82	2405	0.97	—	—	—	—	—	—

Standard Static 1058-1890 RPM, 0.44 Max BHP

Medium Static 1058-2190 RPM, 0.71 Max BHP

High Static 1058-2490 RPM, 1.07 Max BHP

50GCQM04 THREE PHASE - STANDARD STATIC — 3 TON VERTICAL SUPPLY (RPM - VDC)

CFM	AVAILABLE EXTERNAL STATIC PRESSURE (in. wg)									
	0.2		0.4		0.6		0.8		1.0	
	RPM	Vdc	RPM	Vdc	RPM	Vdc	RPM	Vdc	RPM	Vdc
900	1060	5.6	1325	7.0	1541	8.2	1718	9.1	1871	9.9
975	1103	5.8	1355	7.2	1572	8.3	1752	9.3	—	—
1050	1150	6.1	1387	7.3	1602	8.5	1784	9.4	—	—
1125	1198	6.3	1422	7.5	1632	8.6	1815	9.6	—	—
1200	1249	6.6	1460	7.7	1662	8.8	1845	9.8	—	—
1275	1303	6.9	1499	7.9	1694	9.0	1874	9.9	—	—
1350	1357	7.2	1542	8.2	1728	9.1	—	—	—	—
1425	1413	7.5	1587	8.4	1765	9.3	—	—	—	—
1500	1469	7.8	1635	8.7	1803	9.5	—	—	—	—

CFM	AVAILABLE EXTERNAL STATIC PRESSURE (in. wg)									
	1.2		1.4		1.6		1.8		2.0	
	RPM	Vdc	RPM	Vdc	RPM	Vdc	RPM	Vdc	RPM	Vdc
900	—	—	—	—	—	—	—	—	—	—
975	—	—	—	—	—	—	—	—	—	—
1050	—	—	—	—	—	—	—	—	—	—
1125	—	—	—	—	—	—	—	—	—	—
1200	—	—	—	—	—	—	—	—	—	—
1275	—	—	—	—	—	—	—	—	—	—
1350	—	—	—	—	—	—	—	—	—	—
1425	—	—	—	—	—	—	—	—	—	—
1500	—	—	—	—	—	—	—	—	—	—

Standard Static 1060-1890 RPM

50GCQM04 THREE PHASE - MEDIUM STATIC — 3 TON VERTICAL SUPPLY (RPM - VDC)

CFM	AVAILABLE EXTERNAL STATIC PRESSURE (in. wg)									
	0.2		0.4		0.6		0.8		1.0	
	RPM	Vdc	RPM	Vdc	RPM	Vdc	RPM	Vdc	RPM	Vdc
900	1060	4.8	1325	6.1	1541	7.0	1718	7.8	1871	8.5
975	1103	5.0	1355	6.2	1572	7.2	1752	8.0	1906	8.7
1050	1150	5.3	1387	6.3	1602	7.3	1784	8.1	1941	8.9
1125	1198	5.5	1422	6.5	1632	7.5	1815	8.3	1974	9.0
1200	1249	5.7	1460	6.7	1662	7.6	1845	8.4	2005	9.2
1275	1303	5.9	1499	6.8	1694	7.7	1874	8.6	2036	9.3
1350	1357	6.2	1542	7.0	1728	7.9	1905	8.7	2066	9.4
1425	1413	6.5	1587	7.2	1765	8.1	1936	8.8	2095	9.6
1500	1469	6.7	1635	7.5	1803	8.2	1969	9.0	2126	9.7

CFM	AVAILABLE EXTERNAL STATIC PRESSURE (in. wg)									
	1.2		1.4		1.6		1.8		2.0	
	RPM	Vdc	RPM	Vdc	RPM	Vdc	RPM	Vdc	RPM	Vdc
900	2006	9.2	2130	9.7	—	—	—	—	—	—
975	2044	9.3	2169	9.9	—	—	—	—	—	—
1050	2080	9.5	—	—	—	—	—	—	—	—
1125	2115	9.7	—	—	—	—	—	—	—	—
1200	2148	9.8	—	—	—	—	—	—	—	—
1275	2180	10.0	—	—	—	—	—	—	—	—
1350	—	—	—	—	—	—	—	—	—	—
1425	—	—	—	—	—	—	—	—	—	—
1500	—	—	—	—	—	—	—	—	—	—

Medium Static 1060-2190 RPM

50GCQM04 THREE PHASE - HIGH STATIC — 3 TON VERTICAL SUPPLY (RPM - VDC)

CFM	AVAILABLE EXTERNAL STATIC PRESSURE (in. wg)									
	0.2		0.4		0.6		0.8		1.0	
	RPM	Vdc	RPM	Vdc	RPM	Vdc	RPM	Vdc	RPM	Vdc
900	1060	4.3	1325	5.3	1541	6.2	1718	6.9	1871	7.5
975	1103	4.4	1355	5.4	1572	6.3	1752	7.0	1906	7.7
1050	1150	4.6	1387	5.6	1602	6.4	1784	7.2	1941	7.8
1125	1198	4.8	1422	5.7	1632	6.6	1815	7.3	1974	7.9
1200	1249	5.0	1460	5.9	1662	6.7	1845	7.4	2005	8.1
1275	1303	5.2	1499	6.0	1694	6.8	1874	7.5	2036	8.2
1350	1357	5.4	1542	6.2	1728	6.9	1905	7.7	2066	8.3
1425	1413	5.7	1587	6.4	1765	7.1	1936	7.8	2095	8.4
1500	1469	5.9	1635	6.6	1803	7.2	1969	7.9	2126	8.5

CFM	AVAILABLE EXTERNAL STATIC PRESSURE (in. wg)									
	1.2		1.4		1.6		1.8		2.0	
	RPM	Vdc	RPM	Vdc	RPM	Vdc	RPM	Vdc	RPM	Vdc
900	2006	8.1	2130	8.6	2245	9.0	2352	9.4	2454	9.9
975	2044	8.2	2169	8.7	2284	9.2	2391	9.6	—	—
1050	2080	8.4	2206	8.9	2322	9.3	2430	9.8	—	—
1125	2115	8.5	2242	9.0	2360	9.5	2469	9.9	—	—
1200	2148	8.6	2277	9.1	2396	9.6	—	—	—	—
1275	2180	8.8	2311	9.3	2431	9.8	—	—	—	—
1350	2211	8.9	2343	9.4	2465	9.9	—	—	—	—
1425	2241	9.0	2375	9.5	—	—	—	—	—	—
1500	2271	9.1	2405	9.7	—	—	—	—	—	—

High Static 1060-2490 RPM

50GQM05 SINGLE PHASE — 4 TON VERTICAL SUPPLY (RPM - BHP)

CFM	AVAILABLE EXTERNAL STATIC PRESSURE (in. wg)									
	0.2		0.4		0.6		0.8		1.0	
	RPM	BHP	RPM	BHP	RPM	BHP	RPM	BHP	RPM	BHP
1200	1048	0.12	1251	0.21	1431	0.32	1590	0.43	1735	0.56
1300	1102	0.14	1293	0.23	1467	0.34	1622	0.46	1765	0.59
1400	1158	0.17	1337	0.26	1505	0.36	1657	0.49	1796	0.62
1500	1217	0.19	1383	0.28	1545	0.39	1693	0.52	1830	0.65
1600	1277	0.22	1432	0.31	1587	0.42	1731	0.55	1865	0.69
1700	1340	0.25	1483	0.34	1631	0.46	1771	0.59	1902	0.73
1800	1404	0.29	1536	0.38	1677	0.50	1812	0.63	1940	0.77
1900	1469	0.33	1592	0.42	1724	0.54	1855	0.67	1980	0.81
2000	1535	0.38	1649	0.47	1774	0.58	1900	0.72	2021	0.86

CFM	AVAILABLE EXTERNAL STATIC PRESSURE (in. wg)									
	1.2		1.4		1.6		1.8		2.0	
	RPM	BHP	RPM	BHP	RPM	BHP	RPM	BHP	RPM	BHP
1200	1869	0.70	1994	0.86	2111	1.02	2221	1.18	2324	1.35
1300	1897	0.73	2020	0.89	2136	1.05	2246	1.22	2350	1.39
1400	1926	0.76	2048	0.92	2162	1.08	2271	1.25	2375	1.43
1500	1957	0.80	2077	0.95	2190	1.12	2298	1.29	2400	1.47
1600	1990	0.84	2107	0.99	2219	1.16	2325	1.33	2427	1.52
1700	2024	0.88	2140	1.04	2250	1.20	2354	1.38	2455	1.56
1800	2060	0.92	2174	1.08	2282	1.25	2385	1.43	—	—
1900	2097	0.97	2209	1.13	2315	1.30	2417	1.48	—	—
2000	2136	1.02	2246	1.19	2350	1.36	2451	1.54	—	—

Standard Static 1048-1900 RPM, 0.72 Max BHP

Medium Static 1047-2170 RPM, 1.06 Max BHP

High Static 1047-2460 RPM, 1.53 Max BHP

50GQM05 SINGLE PHASE - STANDARD STATIC — 4 TON VERTICAL SUPPLY (RPM - VDC)

CFM	AVAILABLE EXTERNAL STATIC PRESSURE (in. wg)									
	0.2		0.4		0.6		0.8		1.0	
	RPM	Vdc	RPM	Vdc	RPM	Vdc	RPM	Vdc	RPM	Vdc
1200	1047	5.5	1251	6.6	1431	7.5	1590	8.4	1735	9.1
1300	1101	5.8	1293	6.8	1467	7.7	1622	8.5	1765	9.3
1400	1158	6.1	1337	7.0	1505	7.9	1657	8.7	1796	9.5
1500	1217	6.4	1383	7.3	1545	8.1	1693	8.9	1830	9.6
1600	1278	6.7	1432	7.5	1587	8.4	1731	9.1	1865	9.8
1700	1340	7.1	1483	7.8	1631	8.6	1771	9.3	—	—
1800	1404	7.4	1536	8.1	1677	8.8	1812	9.5	—	—
1900	1469	7.7	1592	8.4	1724	9.1	1855	9.8	—	—
2000	1535	8.1	1649	8.7	1774	9.3	1900	10.0	—	—

CFM	AVAILABLE EXTERNAL STATIC PRESSURE (in. wg)									
	1.2		1.4		1.6		1.8		2.0	
	RPM	Vdc	RPM	Vdc	RPM	Vdc	RPM	Vdc	RPM	Vdc
1200	1869	9.8	—	—	—	—	—	—	—	—
1300	1897	10.0	—	—	—	—	—	—	—	—
1400	—	—	—	—	—	—	—	—	—	—
1500	—	—	—	—	—	—	—	—	—	—
1600	—	—	—	—	—	—	—	—	—	—
1700	—	—	—	—	—	—	—	—	—	—
1800	—	—	—	—	—	—	—	—	—	—
1900	—	—	—	—	—	—	—	—	—	—
2000	—	—	—	—	—	—	—	—	—	—

Standard Static 1047-1900 RPM



50GCQM05 SINGLE PHASE - MEDIUM STATIC — 4 TON VERTICAL SUPPLY (RPM - VDC)

CFM	AVAILABLE EXTERNAL STATIC PRESSURE (in. wg)									
	0.2		0.4		0.6		0.8		1.0	
	RPM	Vdc	RPM	Vdc	RPM	Vdc	RPM	Vdc	RPM	Vdc
1200	1047	4.8	1251	5.8	1431	6.6	1590	7.3	1735	8.0
1300	1101	5.1	1293	6.0	1467	6.8	1622	7.5	1765	8.1
1400	1158	5.3	1337	6.2	1505	6.9	1657	7.6	1796	8.3
1500	1217	5.6	1383	6.4	1545	7.1	1693	7.8	1830	8.4
1600	1278	5.9	1432	6.6	1587	7.3	1731	8.0	1865	8.6
1700	1340	6.2	1483	6.8	1631	7.5	1771	8.2	1902	8.8
1800	1404	6.5	1536	7.1	1677	7.7	1812	8.4	1940	8.9
1900	1469	6.8	1592	7.3	1724	7.9	1855	8.5	1980	9.1
2000	1535	7.1	1649	7.6	1774	8.2	1900	8.8	2021	9.3

CFM	AVAILABLE EXTERNAL STATIC PRESSURE (in. wg)									
	1.2		1.4		1.6		1.8		2.0	
	RPM	Vdc	RPM	Vdc	RPM	Vdc	RPM	Vdc	RPM	Vdc
1200	1869	8.6	1994	9.2	2111	9.7	—	—	—	—
1300	1897	8.7	2020	9.3	2136	9.8	—	—	—	—
1400	1926	8.9	2047	9.4	2162	10.0	—	—	—	—
1500	1957	9.0	2077	9.6	—	—	—	—	—	—
1600	1990	9.2	2107	9.7	—	—	—	—	—	—
1700	2024	9.3	2140	9.9	—	—	—	—	—	—
1800	2060	9.5	—	—	—	—	—	—	—	—
1900	2097	9.7	—	—	—	—	—	—	—	—
2000	2136	9.8	—	—	—	—	—	—	—	—

Medium Static 1047-2170 RPM

50GCQM05 SINGLE PHASE - HIGH STATIC — 4 TON VERTICAL SUPPLY (RPM - VDC)

CFM	AVAILABLE EXTERNAL STATIC PRESSURE (in. wg)									
	0.2		0.4		0.6		0.8		1.0	
	RPM	Vdc	RPM	Vdc	RPM	Vdc	RPM	Vdc	RPM	Vdc
1200	1047	4.3	1251	5.1	1431	5.8	1590	6.5	1735	7.1
1300	1101	4.5	1293	5.3	1467	6.0	1622	6.6	1765	7.2
1400	1158	4.7	1337	5.4	1505	6.1	1657	6.7	1796	7.3
1500	1217	4.9	1383	5.6	1545	6.3	1693	6.9	1830	7.4
1600	1278	5.2	1432	5.8	1587	6.5	1731	7.0	1865	7.6
1700	1340	5.4	1483	6.0	1631	6.6	1771	7.2	1902	7.7
1800	1404	5.7	1536	6.2	1677	6.8	1812	7.4	1940	7.9
1900	1469	6.0	1592	6.5	1724	7.0	1855	7.5	1980	8.0
2000	1535	6.2	1649	6.7	1774	7.2	1900	7.7	2021	8.2

CFM	AVAILABLE EXTERNAL STATIC PRESSURE (in. wg)									
	1.2		1.4		1.6		1.8		2.0	
	RPM	Vdc	RPM	Vdc	RPM	Vdc	RPM	Vdc	RPM	Vdc
1200	1869	7.6	1994	8.1	2111	8.6	2221	9.0	2324	9.4
1300	1897	7.7	2020	8.2	2136	8.7	2246	9.1	2350	9.6
1400	1926	7.8	2047	8.3	2162	8.8	2271	9.2	2375	9.7
1500	1957	8.0	2077	8.4	2190	8.9	2297	9.3	2400	9.8
1600	1990	8.1	2107	8.6	2219	9.0	2325	9.5	2427	9.9
1700	2024	8.2	2140	8.7	2249	9.1	2354	9.6	2455	10.0
1800	2060	8.4	2174	8.8	2282	9.3	2385	9.7	—	—
1900	2097	8.5	2209	9.0	2315	9.4	2417	9.8	—	—
2000	2136	8.7	2246	9.1	2350	9.6	2450	10.0	—	—

High Static 1047-2460 RPM

50GCQM05 THREE PHASE — 4 TON VERTICAL SUPPLY (RPM - BHP)

CFM	AVAILABLE EXTERNAL STATIC PRESSURE (in. wg)									
	0.2		0.4		0.6		0.8		1.0	
	RPM	BHP	RPM	BHP	RPM	BHP	RPM	BHP	RPM	BHP
1200	1047	0.12	1252	0.21	1431	0.32	1590	0.43	1735	0.56
1300	1102	0.14	1293	0.23	1467	0.34	1622	0.46	1765	0.59
1400	1158	0.17	1337	0.26	1505	0.36	1657	0.49	1796	0.62
1500	1217	0.19	1383	0.28	1545	0.39	1693	0.52	1830	0.65
1600	1278	0.22	1432	0.31	1587	0.42	1732	0.55	1865	0.69
1700	1341	0.25	1483	0.34	1631	0.46	1771	0.59	1902	0.73
1800	1404	0.29	1536	0.38	1676	0.50	1813	0.63	1940	0.77
1900	1470	0.33	1592	0.42	1724	0.54	1855	0.67	1980	0.81
2000	1536	0.38	1649	0.47	1774	0.58	1900	0.72	2021	0.86

CFM	AVAILABLE EXTERNAL STATIC PRESSURE (in. wg)									
	1.2		1.4		1.6		1.8		2.0	
	RPM	BHP	RPM	BHP	RPM	BHP	RPM	BHP	RPM	BHP
1200	1869	0.70	1994	0.86	2111	1.02	2221	1.18	2324	1.35
1300	1897	0.73	2020	0.89	2136	1.05	2246	1.22	2350	1.39
1400	1926	0.76	2047	0.92	2162	1.08	2271	1.25	2375	1.43
1500	1957	0.80	2077	0.95	2190	1.12	2297	1.29	2400	1.47
1600	1990	0.84	2107	0.99	2219	1.16	2325	1.33	2427	1.52
1700	2024	0.88	2140	1.04	2250	1.20	2354	1.38	2455	1.56
1800	2060	0.92	2174	1.08	2282	1.25	2385	1.43	2484	1.61
1900	2098	0.97	2209	1.13	2315	1.30	2417	1.48	2515	1.67
2000	2137	1.02	2246	1.19	2351	1.36	2451	1.54	2547	1.73

Standard Static 1047-1900 RPM, 0.72 Max BHP

Medium Static 1047-2170 RPM, 1.06 Max BHP

High Static 1047-2660 RPM, 1.96 Max BHP

50GCQM05 THREE PHASE - STANDARD STATIC — 4 TON VERTICAL SUPPLY (RPM - VDC)

CFM	AVAILABLE EXTERNAL STATIC PRESSURE (in. wg)									
	0.2		0.4		0.6		0.8		1.0	
	RPM	Vdc	RPM	Vdc	RPM	Vdc	RPM	Vdc	RPM	Vdc
1200	1047	5.5	1251	6.6	1431	7.5	1590	8.4	1735	9.1
1300	1101	5.8	1293	6.8	1467	7.7	1622	8.5	1765	9.3
1400	1158	6.1	1337	7.0	1505	7.9	1657	8.7	1796	9.5
1500	1217	6.4	1383	7.3	1545	8.1	1693	8.9	1830	9.6
1600	1277	6.7	1432	7.5	1587	8.4	1731	9.1	1865	9.8
1700	1340	7.1	1483	7.8	1631	8.6	1771	9.3	—	—
1800	1404	7.4	1536	8.1	1677	8.8	1812	9.5	—	—
1900	1469	7.7	1592	8.4	1724	9.1	1855	9.8	—	—
2000	1535	8.1	1649	8.7	1774	9.3	1900	10.0	—	—

CFM	AVAILABLE EXTERNAL STATIC PRESSURE (in. wg)									
	1.2		1.4		1.6		1.8		2.0	
	RPM	Vdc	RPM	Vdc	RPM	Vdc	RPM	Vdc	RPM	Vdc
1200	1869	9.8	—	—	—	—	—	—	—	—
1300	1897	10.0	—	—	—	—	—	—	—	—
1400	—	—	—	—	—	—	—	—	—	—
1500	—	—	—	—	—	—	—	—	—	—
1600	—	—	—	—	—	—	—	—	—	—
1700	—	—	—	—	—	—	—	—	—	—
1800	—	—	—	—	—	—	—	—	—	—
1900	—	—	—	—	—	—	—	—	—	—
2000	—	—	—	—	—	—	—	—	—	—

Standard Static 1047-1900 RPM

50GCQM05 THREE PHASE - MEDIUM STATIC — 4 TON VERTICAL SUPPLY (RPM - VDC)

CFM	AVAILABLE EXTERNAL STATIC PRESSURE (in. wg)									
	0.2		0.4		0.6		0.8		1.0	
	RPM	Vdc	RPM	Vdc	RPM	Vdc	RPM	Vdc	RPM	Vdc
1200	1047	4.8	1251	5.8	1431	6.6	1590	7.3	1735	8.0
1300	1101	5.1	1293	6.0	1467	6.8	1622	7.5	1765	8.1
1400	1158	5.3	1337	6.2	1505	6.9	1657	7.6	1796	8.3
1500	1217	5.6	1383	6.4	1545	7.1	1693	7.8	1830	8.4
1600	1277	5.9	1432	6.6	1587	7.3	1731	8.0	1865	8.6
1700	1340	6.2	1483	6.8	1631	7.5	1771	8.2	1902	8.8
1800	1404	6.5	1536	7.1	1677	7.7	1812	8.4	1940	8.9
1900	1469	6.8	1592	7.3	1724	7.9	1855	8.5	1980	9.1
2000	1535	7.1	1649	7.6	1774	8.2	1900	8.8	2021	9.3

CFM	AVAILABLE EXTERNAL STATIC PRESSURE (in. wg)									
	1.2		1.4		1.6		1.8		2.0	
	RPM	Vdc	RPM	Vdc	RPM	Vdc	RPM	Vdc	RPM	Vdc
1200	1869	8.6	1994	9.2	2111	9.7	—	—	—	—
1300	1897	8.7	2020	9.3	2136	9.8	—	—	—	—
1400	1926	8.9	2048	9.4	2162	10.0	—	—	—	—
1500	1957	9.0	2077	9.6	—	—	—	—	—	—
1600	1990	9.2	2107	9.7	—	—	—	—	—	—
1700	2024	9.3	2140	9.9	—	—	—	—	—	—
1800	2060	9.5	—	—	—	—	—	—	—	—
1900	2097	9.7	—	—	—	—	—	—	—	—
2000	2136	9.8	—	—	—	—	—	—	—	—

Medium Static 1047-2170 RPM

50GCQM05 THREE PHASE - HIGH STATIC — 4 TON VERTICAL SUPPLY (RPM - VDC)

CFM	AVAILABLE EXTERNAL STATIC PRESSURE (in. wg)									
	0.2		0.4		0.6		0.8		1.0	
	RPM	Vdc	RPM	Vdc	RPM	Vdc	RPM	Vdc	RPM	Vdc
1200	1047	3.9	1251	4.7	1431	5.4	1590	6.0	1735	6.5
1300	1101	4.1	1293	4.9	1467	5.5	1622	6.1	1765	6.6
1400	1158	4.4	1337	5.0	1505	5.7	1657	6.2	1796	6.8
1500	1217	4.6	1383	5.2	1545	5.8	1693	6.4	1830	6.9
1600	1277	4.8	1432	5.4	1587	6.0	1731	6.5	1865	7.0
1700	1340	5.0	1483	5.6	1631	6.1	1771	6.7	1902	7.2
1800	1404	5.3	1536	5.8	1677	6.3	1812	6.8	1940	7.3
1900	1469	5.5	1592	6.0	1724	6.5	1855	7.0	1980	7.4
2000	1535	5.8	1649	6.2	1774	6.7	1900	7.1	2021	7.6

CFM	AVAILABLE EXTERNAL STATIC PRESSURE (in. wg)									
	1.2		1.4		1.6		1.8		2.0	
	RPM	Vdc	RPM	Vdc	RPM	Vdc	RPM	Vdc	RPM	Vdc
1200	1869	7.0	1994	7.5	2111	7.9	2221	8.3	2324	8.7
1300	1897	7.1	2020	7.6	2136	8.0	2246	8.4	2350	8.8
1400	1926	7.2	2048	7.7	2162	8.1	2271	8.5	2375	8.9
1500	1957	7.4	2077	7.8	2190	8.2	2298	8.6	2400	9.0
1600	1990	7.5	2107	7.9	2219	8.3	2325	8.7	2427	9.1
1700	2024	7.6	2140	8.0	2250	8.5	2354	8.8	2455	9.2
1800	2060	7.7	2174	8.2	2282	8.6	2385	9.0	2484	9.3
1900	2097	7.9	2209	8.3	2315	8.7	2417	9.1	2515	9.5
2000	2136	8.0	2246	8.4	2350	8.8	2451	9.2	2547	9.6

High Static 1047-2660 RPM

50GQM06 SINGLE PHASE — 5 TON VERTICAL SUPPLY (RPM - BHP)

CFM	AVAILABLE EXTERNAL STATIC PRESSURE (in. wg)									
	0.2		0.4		0.6		0.8		1.0	
	RPM	BHP	RPM	BHP	RPM	BHP	RPM	BHP	RPM	BHP
1500	1228	0.20	1394	0.29	1554	0.40	1701	0.53	1836	0.66
1625	1305	0.24	1457	0.33	1609	0.44	1750	0.57	1882	0.71
1750	1384	0.28	1523	0.37	1666	0.49	1802	0.62	1930	0.76
1875	1466	0.33	1592	0.43	1726	0.54	1857	0.67	1981	0.82
2000	1549	0.39	1664	0.48	1789	0.60	1914	0.74	2034	0.88
2125	1633	0.46	1738	0.55	1855	0.67	1974	0.81	2089	0.95
2250	1718	0.53	1816	0.63	1924	0.74	2036	0.88	2146	1.03
2375	1803	0.61	1894	0.71	1995	0.83	2100	0.97	2206	1.12
2500	1889	0.70	1974	0.80	2068	0.92	2167	1.06	2268	1.21

CFM	AVAILABLE EXTERNAL STATIC PRESSURE (in. wg)									
	1.2		1.4		1.6		1.8		2.0	
	RPM	BHP	RPM	BHP	RPM	BHP	RPM	BHP	RPM	BHP
1500	1961	0.80	2079	0.96	2191	1.12	2298	1.29	2399	1.47
1625	2004	0.85	2120	1.01	2230	1.18	2335	1.35	2435	1.53
1750	2050	0.91	2163	1.07	2271	1.24	2374	1.41	2472	1.60
1875	2098	0.97	2208	1.13	2314	1.31	2415	1.48	2512	1.67
2000	2148	1.04	2256	1.21	2359	1.38	2458	1.56	2553	1.75
2125	2200	1.11	2305	1.28	2407	1.46	2504	1.64	2597	1.83
2250	2254	1.20	2357	1.37	2456	1.55	2551	1.73	2643	1.93
2375	2310	1.28	2410	1.46	2507	1.64	2600	1.83	—	—
2500	2368	1.38	2466	1.56	2560	1.75	2651	1.94	—	—

Standard Static 1228-2150 RPM, 1.06 Max BHP

Medium Static 1228-2390 RPM, 1.44 Max BHP

High Static 1228-2660 RPM, 1.96 Max BHP

50GQM06 SINGLE PHASE - STANDARD STATIC — 5 TON VERTICAL SUPPLY (RPM - VDC)

CFM	AVAILABLE EXTERNAL STATIC PRESSURE (in. wg)									
	0.2		0.4		0.6		0.8		1.0	
	RPM	Vdc	RPM	Vdc	RPM	Vdc	RPM	Vdc	RPM	Vdc
1500	1228	5.7	1394	6.5	1554	7.2	1701	7.9	1835	8.5
1625	1305	6.1	1456	6.8	1609	7.5	1750	8.1	1881	8.7
1750	1385	6.4	1523	7.1	1666	7.7	1802	8.4	1930	9.0
1875	1466	6.8	1592	7.4	1726	8.0	1857	8.6	1981	9.2
2000	1549	7.2	1664	7.7	1789	8.3	1914	8.9	2034	9.5
2125	1633	7.6	1739	8.1	1855	8.6	1974	9.2	2089	9.7
2250	1718	8.0	1816	8.4	1924	8.9	2036	9.5	2146	10.0
2375	1803	8.4	1894	8.8	1995	9.3	2100	9.8	—	—
2500	1890	8.8	1974	9.2	2068	9.6	—	—	—	—

CFM	AVAILABLE EXTERNAL STATIC PRESSURE (in. wg)									
	1.2		1.4		1.6		1.8		2.0	
	RPM	Vdc	RPM	Vdc	RPM	Vdc	RPM	Vdc	RPM	Vdc
1500	1961	9.1	2079	9.7	—	—	—	—	—	—
1625	2004	9.3	2120	9.9	—	—	—	—	—	—
1750	2050	9.5	—	—	—	—	—	—	—	—
1875	2098	9.8	—	—	—	—	—	—	—	—
2000	2148	10.0	—	—	—	—	—	—	—	—
2125	—	—	—	—	—	—	—	—	—	—
2250	—	—	—	—	—	—	—	—	—	—
2375	—	—	—	—	—	—	—	—	—	—
2500	—	—	—	—	—	—	—	—	—	—

Standard Static 1228-2150 RPM



50GCQM06 SINGLE PHASE - MEDIUM STATIC — 5 TON VERTICAL SUPPLY (RPM - VDC)

CFM	AVAILABLE EXTERNAL STATIC PRESSURE (in. wg)									
	0.2		0.4		0.6		0.8		1.0	
	RPM	Vdc	RPM	Vdc	RPM	Vdc	RPM	Vdc	RPM	Vdc
1500	1228	5.1	1394	5.8	1554	6.5	1701	7.1	1835	7.7
1625	1305	5.5	1456	6.1	1609	6.7	1750	7.3	1881	7.9
1750	1385	5.8	1523	6.4	1666	7.0	1802	7.5	1930	8.1
1875	1466	6.1	1592	6.7	1726	7.2	1857	7.8	1981	8.3
2000	1549	6.5	1664	7.0	1789	7.5	1914	8.0	2034	8.5
2125	1633	6.8	1739	7.3	1855	7.8	1974	8.3	2089	8.7
2250	1718	7.2	1816	7.6	1924	8.1	2036	8.5	2146	9.0
2375	1803	7.5	1894	7.9	1995	8.3	2100	8.8	2206	9.2
2500	1890	7.9	1974	8.3	2068	8.7	2167	9.1	2268	9.5

CFM	AVAILABLE EXTERNAL STATIC PRESSURE (in. wg)									
	1.2		1.4		1.6		1.8		2.0	
	RPM	Vdc	RPM	Vdc	RPM	Vdc	RPM	Vdc	RPM	Vdc
1500	1961	8.2	2079	8.7	2191	9.2	2297	9.6	—	—
1625	2004	8.4	2120	8.9	2229	9.3	2334	9.8	—	—
1750	2050	8.6	2163	9.1	2270	9.5	2373	9.9	—	—
1875	2098	8.8	2208	9.2	2314	9.7	—	—	—	—
2000	2148	9.0	2256	9.4	2359	9.9	—	—	—	—
2125	2200	9.2	2305	9.6	—	—	—	—	—	—
2250	2254	9.4	2357	9.9	—	—	—	—	—	—
2375	2310	9.7	—	—	—	—	—	—	—	—
2500	2368	9.9	—	—	—	—	—	—	—	—

Medium Static 1228-2390 RPM

50GCQM06 SINGLE PHASE - HIGH STATIC — 5 TON VERTICAL SUPPLY (RPM - VDC)

CFM	AVAILABLE EXTERNAL STATIC PRESSURE (in. wg)									
	0.2		0.4		0.6		0.8		1.0	
	RPM	Vdc	RPM	Vdc	RPM	Vdc	RPM	Vdc	RPM	Vdc
1500	1228	4.6	1394	5.2	1554	5.8	1701	6.4	1835	6.9
1625	1305	4.9	1456	5.5	1609	6.0	1750	6.6	1881	7.1
1750	1385	5.2	1523	5.7	1666	6.3	1802	6.8	1930	7.3
1875	1466	5.5	1592	6.0	1726	6.5	1857	7.0	1981	7.4
2000	1549	5.8	1664	6.3	1789	6.7	1914	7.2	2034	7.6
2125	1633	6.1	1739	6.5	1855	7.0	1974	7.4	2089	7.9
2250	1718	6.5	1816	6.8	1924	7.2	2036	7.7	2146	8.1
2375	1803	6.8	1894	7.1	1995	7.5	2100	7.9	2206	8.3
2500	1890	7.1	1974	7.4	2068	7.8	2167	8.1	2268	8.5

CFM	AVAILABLE EXTERNAL STATIC PRESSURE (in. wg)									
	1.2		1.4		1.6		1.8		2.0	
	RPM	Vdc	RPM	Vdc	RPM	Vdc	RPM	Vdc	RPM	Vdc
1500	1961	7.4	2079	7.8	2191	8.2	2297	8.6	2399	9.0
1625	2004	7.5	2120	8.0	2229	8.4	2334	8.8	2434	9.2
1750	2050	7.7	2163	8.1	2270	8.5	2373	8.9	2472	9.3
1875	2098	7.9	2208	8.3	2314	8.7	2414	9.1	2511	9.4
2000	2148	8.1	2256	8.5	2359	8.9	2458	9.2	2553	9.6
2125	2200	8.3	2305	8.7	2407	9.0	2504	9.4	2597	9.8
2250	2254	8.5	2357	8.9	2456	9.2	2551	9.6	2643	9.9
2375	2310	8.7	2410	9.1	2507	9.4	2600	9.8	—	—
2500	2368	8.9	2465	9.3	2560	9.6	2651	10.0	—	—

High Static 1228-2660 RPM

50GCQM06 THREE PHASE — 5 TON VERTICAL SUPPLY (RPM - BHP)

CFM	AVAILABLE EXTERNAL STATIC PRESSURE (in. wg)									
	0.2		0.4		0.6		0.8		1.0	
	RPM	BHP	RPM	BHP	RPM	BHP	RPM	BHP	RPM	BHP
1500	1228	0.20	1394	0.29	1554	0.40	1701	0.53	1836	0.66
1625	1305	0.24	1457	0.33	1609	0.44	1750	0.57	1882	0.71
1750	1384	0.28	1523	0.37	1666	0.49	1802	0.62	1930	0.76
1875	1466	0.33	1592	0.43	1726	0.54	1857	0.67	1981	0.82
2000	1549	0.39	1664	0.48	1789	0.60	1914	0.74	2034	0.88
2125	1633	0.46	1739	0.55	1855	0.67	1974	0.81	2089	0.95
2250	1718	0.53	1816	0.63	1924	0.74	2036	0.88	2146	1.03
2375	1803	0.61	1894	0.71	1995	0.83	2100	0.97	2206	1.12
2500	1890	0.70	1974	0.80	2068	0.92	2167	1.06	2268	1.21

CFM	AVAILABLE EXTERNAL STATIC PRESSURE (in. wg)									
	1.2		1.4		1.6		1.8		2.0	
	RPM	BHP	RPM	BHP	RPM	BHP	RPM	BHP	RPM	BHP
1500	1961	0.80	2079	0.96	2191	1.12	2297	1.29	2399	1.47
1625	2004	0.85	2120	1.01	2230	1.18	2334	1.35	2434	1.53
1750	2050	0.91	2163	1.07	2270	1.24	2373	1.41	2472	1.60
1875	2098	0.97	2208	1.13	2314	1.31	2414	1.48	2511	1.67
2000	2148	1.04	2256	1.21	2359	1.38	2458	1.56	2553	1.75
2125	2200	1.11	2305	1.28	2407	1.46	2504	1.64	2597	1.83
2250	2254	1.20	2357	1.37	2456	1.55	2551	1.73	2643	1.93
2375	2310	1.28	2410	1.46	2507	1.64	2600	1.83	2690	2.03
2500	2368	1.38	2465	1.56	2560	1.75	2651	1.94	2739	2.14

Standard Static 1228-2150 RPM, 1.06 Max BHP

Medium Static 1228-2390 RPM, 1.44 Max BHP

High Static 1228-2836 RPM, 2.43 Max BHP

50GCQM06 THREE PHASE - STANDARD STATIC — 5 TON VERTICAL SUPPLY (RPM - VDC)

CFM	AVAILABLE EXTERNAL STATIC PRESSURE (in. wg)									
	0.2		0.4		0.6		0.8		1.0	
	RPM	Vdc	RPM	Vdc	RPM	Vdc	RPM	Vdc	RPM	Vdc
1500	1227	5.7	1394	6.5	1554	7.2	1701	7.9	1835	8.5
1625	1305	6.1	1456	6.8	1609	7.5	1750	8.1	1881	8.7
1750	1385	6.4	1523	7.1	1666	7.7	1802	8.4	1930	9.0
1875	1466	6.8	1592	7.4	1726	8.0	1857	8.6	1981	9.2
2000	1549	7.2	1664	7.7	1789	8.3	1914	8.9	2034	9.5
2125	1632	7.6	1739	8.1	1855	8.6	1974	9.2	2089	9.7
2250	1718	8.0	1816	8.4	1924	8.9	2035	9.5	2146	10.0
2375	1803	8.4	1894	8.8	1994	9.3	2100	9.8	—	—
2500	1890	8.8	1974	9.2	2068	9.6	—	—	—	—

CFM	AVAILABLE EXTERNAL STATIC PRESSURE (in. wg)									
	1.2		1.4		1.6		1.8		2.0	
	RPM	Vdc	RPM	Vdc	RPM	Vdc	RPM	Vdc	RPM	Vdc
1500	1961	9.1	2079	9.7	—	—	—	—	—	—
1625	2004	9.3	2120	9.9	—	—	—	—	—	—
1750	2050	9.5	—	—	—	—	—	—	—	—
1875	2097	9.8	—	—	—	—	—	—	—	—
2000	2147	10.0	—	—	—	—	—	—	—	—
2125	—	—	—	—	—	—	—	—	—	—
2250	—	—	—	—	—	—	—	—	—	—
2375	—	—	—	—	—	—	—	—	—	—
2500	—	—	—	—	—	—	—	—	—	—

Standard Static 1227-2150 RPM

50GCQM06 THREE PHASE - MEDIUM STATIC — 5 TON VERTICAL SUPPLY (RPM - VDC)

CFM	AVAILABLE EXTERNAL STATIC PRESSURE (in. wg)									
	0.2		0.4		0.6		0.8		1.0	
	RPM	Vdc	RPM	Vdc	RPM	Vdc	RPM	Vdc	RPM	Vdc
1500	1227	5.1	1394	5.8	1554	6.5	1701	7.1	1835	7.7
1625	1305	5.5	1456	6.1	1609	6.7	1750	7.3	1881	7.9
1750	1385	5.8	1523	6.4	1666	7.0	1802	7.5	1930	8.1
1875	1466	6.1	1592	6.7	1726	7.2	1857	7.8	1981	8.3
2000	1549	6.5	1664	7.0	1789	7.5	1914	8.0	2034	8.5
2125	1632	6.8	1739	7.3	1855	7.8	1974	8.3	2089	8.7
2250	1718	7.2	1816	7.6	1924	8.1	2035	8.5	2146	9.0
2375	1803	7.5	1894	7.9	1994	8.3	2100	8.8	2206	9.2
2500	1890	7.9	1974	8.3	2068	8.7	2167	9.1	2268	9.5

CFM	AVAILABLE EXTERNAL STATIC PRESSURE (in. wg)									
	1.2		1.4		1.6		1.8		2.0	
	RPM	Vdc	RPM	Vdc	RPM	Vdc	RPM	Vdc	RPM	Vdc
1500	1961	8.2	2079	8.7	2191	9.2	2297	9.6	—	—
1625	2004	8.4	2120	8.9	2229	9.3	2334	9.8	—	—
1750	2050	8.6	2163	9.1	2270	9.5	2373	9.9	—	—
1875	2097	8.8	2208	9.2	2314	9.7	—	—	—	—
2000	2147	9.0	2256	9.4	2359	9.9	—	—	—	—
2125	2199	9.2	2305	9.6	—	—	—	—	—	—
2250	2254	9.4	2357	9.9	—	—	—	—	—	—
2375	2310	9.7	—	—	—	—	—	—	—	—
2500	2367	9.9	—	—	—	—	—	—	—	—

Medium Static 1227-2390 RPM

50GCQM06 THREE PHASE - HIGH STATIC — 5 TON VERTICAL SUPPLY (RPM - VDC)

CFM	AVAILABLE EXTERNAL STATIC PRESSURE (in. wg)									
	0.2		0.4		0.6		0.8		1.0	
	RPM	Vdc	RPM	Vdc	RPM	Vdc	RPM	Vdc	RPM	Vdc
1500	1227	4.3	1394	4.9	1554	5.5	1701	6.0	1835	6.5
1625	1305	4.6	1456	5.1	1609	5.7	1750	6.2	1881	6.6
1750	1385	4.9	1523	5.4	1666	5.9	1802	6.4	1930	6.8
1875	1466	5.2	1592	5.6	1726	6.1	1857	6.5	1981	7.0
2000	1549	5.5	1664	5.9	1789	6.3	1914	6.7	2034	7.2
2125	1632	5.8	1739	6.1	1855	6.5	1974	7.0	2089	7.4
2250	1718	6.1	1816	6.4	1924	6.8	2035	7.2	2146	7.6
2375	1803	6.4	1894	6.7	1994	7.0	2100	7.4	2206	7.8
2500	1890	6.7	1974	7.0	2068	7.3	2167	7.6	2268	8.0

CFM	AVAILABLE EXTERNAL STATIC PRESSURE (in. wg)									
	1.2		1.4		1.6		1.8		2.0	
	RPM	Vdc	RPM	Vdc	RPM	Vdc	RPM	Vdc	RPM	Vdc
1500	1961	6.9	2079	7.3	2191	7.7	2297	8.1	2399	8.5
1625	2004	7.1	2120	7.5	2229	7.9	2334	8.2	2434	8.6
1750	2050	7.2	2163	7.6	2270	8.0	2373	8.4	2472	8.7
1875	2097	7.4	2208	7.8	2314	8.2	2414	8.5	2511	8.9
2000	2147	7.6	2256	8.0	2359	8.3	2458	8.7	2553	9.0
2125	2199	7.8	2305	8.1	2406	8.5	2503	8.8	2597	9.2
2250	2254	7.9	2357	8.3	2456	8.7	2551	9.0	2643	9.3
2375	2310	8.1	2410	8.5	2507	8.8	2600	9.2	2690	9.5
2500	2367	8.3	2465	8.7	2560	9.0	2651	9.3	2739	9.7

High Static 1227-2836 RPM

50GCQM04 SINGLE PHASE — 3 TON HORIZONTAL SUPPLY (RPM - BHP)

CFM	AVAILABLE EXTERNAL STATIC PRESSURE (in. wg)									
	0.2		0.4		0.6		0.8		1.0	
	RPM	BHP	RPM	BHP	RPM	BHP	RPM	BHP	RPM	BHP
900	1036	0.08	1301	0.15	1517	0.24	1698	0.34	1855	0.44
975	1077	0.09	1331	0.16	1546	0.26	1727	0.36	1885	0.47
1050	1119	0.10	1362	0.18	1574	0.27	1755	0.38	1915	0.49
1125	1164	0.11	1394	0.19	1603	0.29	1783	0.39	1944	0.51
1200	1211	0.12	1429	0.20	1632	0.30	1813	0.41	1972	0.53
1275	1261	0.14	1466	0.22	1663	0.32	1841	0.43	2000	0.56
1350	1312	0.16	1506	0.24	1695	0.34	1870	0.46	2029	0.58
1425	1365	0.18	1547	0.26	1729	0.36	1901	0.48	2057	0.61
1500	1419	0.20	1591	0.28	1765	0.38	1932	0.50	2087	0.63

CFM	AVAILABLE EXTERNAL STATIC PRESSURE (in. wg)									
	1.2		1.4		1.6		1.8		2.0	
	RPM	BHP	RPM	BHP	RPM	BHP	RPM	BHP	RPM	BHP
900	1996	0.55	2123	0.67	2242	0.78	2352	0.91	2455	1.03
975	2027	0.58	2157	0.70	2276	0.82	2387	0.95	—	—
1050	2058	0.61	2189	0.73	2309	0.86	2421	0.99	—	—
1125	2088	0.63	2219	0.76	2341	0.89	2454	1.03	—	—
1200	2117	0.66	2249	0.79	2372	0.93	2486	1.07	—	—
1275	2146	0.69	2278	0.82	2402	0.97	—	—	—	—
1350	2174	0.72	2307	0.86	2431	1.00	—	—	—	—
1425	2202	0.74	2336	0.89	2460	1.04	—	—	—	—
1500	2230	0.77	2364	0.92	2488	1.07	—	—	—	—

Standard Static 1036-1890 RPM, 0.44 Max BHP

Medium Static 1036-2190 RPM, 0.71 Max BHP

High Static 1036-2490 RPM, 1.07 Max BHP

50GCQM04 SINGLE PHASE - STANDARD STATIC — 3 TON HORIZONTAL SUPPLY (RPM - VDC)

CFM	AVAILABLE EXTERNAL STATIC PRESSURE (in. wg)									
	0.2		0.4		0.6		0.8		1.0	
	RPM	Vdc	RPM	Vdc	RPM	Vdc	RPM	Vdc	RPM	Vdc
900	1036	5.5	1301	6.9	1517	8.0	1698	9.0	1855	9.8
975	1077	5.7	1331	7.0	1546	8.2	1727	9.1	1885	10.0
1050	1119	5.9	1362	7.2	1574	8.3	1755	9.3	—	—
1125	1164	6.2	1394	7.4	1603	8.5	1783	9.4	—	—
1200	1211	6.4	1429	7.6	1632	8.6	1813	9.6	—	—
1275	1261	6.7	1466	7.8	1663	8.8	1841	9.7	—	—
1350	1312	6.9	1506	8.0	1695	9.0	1870	9.9	—	—
1425	1365	7.2	1547	8.2	1729	9.1	—	—	—	—
1500	1419	7.5	1591	8.4	1765	9.3	—	—	—	—

CFM	AVAILABLE EXTERNAL STATIC PRESSURE (in. wg)									
	1.2		1.4		1.6		1.8		2.0	
	RPM	Vdc	RPM	Vdc	RPM	Vdc	RPM	Vdc	RPM	Vdc
900	—	—	—	—	—	—	—	—	—	—
975	—	—	—	—	—	—	—	—	—	—
1050	—	—	—	—	—	—	—	—	—	—
1125	—	—	—	—	—	—	—	—	—	—
1200	—	—	—	—	—	—	—	—	—	—
1275	—	—	—	—	—	—	—	—	—	—
1350	—	—	—	—	—	—	—	—	—	—
1425	—	—	—	—	—	—	—	—	—	—
1500	—	—	—	—	—	—	—	—	—	—

Standard Static 1036-1890 RPM

50GCQM04 SINGLE PHASE - MEDIUM STATIC — 3 TON HORIZONTAL SUPPLY (RPM - VDC)

CFM	AVAILABLE EXTERNAL STATIC PRESSURE (in. wg)									
	0.2		0.4		0.6		0.8		1.0	
	RPM	Vdc	RPM	Vdc	RPM	Vdc	RPM	Vdc	RPM	Vdc
900	1036	4.7	1301	5.9	1517	6.9	1698	7.8	1855	8.5
975	1077	4.9	1331	6.1	1546	7.1	1727	7.9	1885	8.6
1050	1119	5.1	1362	6.2	1574	7.2	1755	8.0	1915	8.7
1125	1164	5.3	1394	6.4	1603	7.3	1783	8.1	1944	8.9
1200	1211	5.5	1429	6.5	1632	7.5	1813	8.3	1972	9.0
1275	1261	5.8	1466	6.7	1663	7.6	1841	8.4	2000	9.1
1350	1312	6.0	1506	6.9	1695	7.7	1870	8.5	2029	9.3
1425	1365	6.2	1547	7.1	1729	7.9	1901	8.7	2057	9.4
1500	1419	6.5	1591	7.3	1765	8.1	1932	8.8	2087	9.5

CFM	AVAILABLE EXTERNAL STATIC PRESSURE (in. wg)									
	1.2		1.4		1.6		1.8		2.0	
	RPM	Vdc	RPM	Vdc	RPM	Vdc	RPM	Vdc	RPM	Vdc
900	1996	9.1	2123	9.7	—	—	—	—	—	—
975	2027	9.3	2157	9.8	—	—	—	—	—	—
1050	2058	9.4	2189	10.0	—	—	—	—	—	—
1125	2088	9.5	—	—	—	—	—	—	—	—
1200	2117	9.7	—	—	—	—	—	—	—	—
1275	2146	9.8	—	—	—	—	—	—	—	—
1350	2174	9.9	—	—	—	—	—	—	—	—
1425	—	—	—	—	—	—	—	—	—	—
1500	—	—	—	—	—	—	—	—	—	—

Medium Static 1036-2190 RPM

50GCQM04 SINGLE PHASE - HIGH STATIC — 3 TON HORIZONTAL SUPPLY (RPM - VDC)

CFM	AVAILABLE EXTERNAL STATIC PRESSURE (in. wg)									
	0.2		0.4		0.6		0.8		1.0	
	RPM	Vdc	RPM	Vdc	RPM	Vdc	RPM	Vdc	RPM	Vdc
900	1036	4.2	1301	5.2	1517	6.1	1698	6.8	1855	7.4
975	1077	4.3	1331	5.3	1546	6.2	1727	6.9	1885	7.6
1050	1119	4.5	1362	5.5	1574	6.3	1755	7.0	1915	7.7
1125	1164	4.7	1394	5.6	1603	6.4	1783	7.2	1944	7.8
1200	1211	4.9	1429	5.7	1632	6.6	1813	7.3	1972	7.9
1275	1261	5.1	1466	5.9	1663	6.7	1841	7.4	2000	8.0
1350	1312	5.3	1506	6.0	1695	6.8	1870	7.5	2029	8.1
1425	1365	5.5	1547	6.2	1729	6.9	1901	7.6	2057	8.3
1500	1419	5.7	1591	6.4	1765	7.1	1932	7.8	2087	8.4

CFM	AVAILABLE EXTERNAL STATIC PRESSURE (in. wg)									
	1.2		1.4		1.6		1.8		2.0	
	RPM	Vdc	RPM	Vdc	RPM	Vdc	RPM	Vdc	RPM	Vdc
900	1996	8.0	2123	8.5	2242	9.0	2352	9.4	2455	9.9
975	2027	8.1	2157	8.7	2276	9.1	2387	9.6	—	—
1050	2058	8.3	2189	8.8	2309	9.3	2421	9.7	—	—
1125	2088	8.4	2219	8.9	2341	9.4	2454	9.9	—	—
1200	2117	8.5	2249	9.0	2372	9.5	2486	10.0	—	—
1275	2146	8.6	2278	9.1	2402	9.6	—	—	—	—
1350	2174	8.7	2307	9.3	2431	9.8	—	—	—	—
1425	2202	8.8	2336	9.4	2460	9.9	—	—	—	—
1500	2230	9.0	2364	9.5	2488	10.0	—	—	—	—

High Static 1036-2490 RPM

50GCQM04 THREE PHASE — 3 TON HORIZONTAL SUPPLY (RPM - BHP)

CFM	AVAILABLE EXTERNAL STATIC PRESSURE (in. wg)									
	0.2		0.4		0.6		0.8		1.0	
	RPM	BHP	RPM	BHP	RPM	BHP	RPM	BHP	RPM	BHP
900	1037	0.08	1301	0.15	1517	0.24	1698	0.34	1855	0.44
975	1076	0.09	1330	0.16	1545	0.26	1727	0.36	1886	0.47
1050	1119	0.10	1361	0.18	1574	0.27	1755	0.38	1915	0.49
1125	1164	0.11	1394	0.19	1602	0.29	1784	0.40	1944	0.51
1200	1212	0.12	1430	0.20	1632	0.30	1813	0.41	1972	0.53
1275	1261	0.14	1466	0.22	1663	0.32	1840	0.43	2001	0.56
1350	1313	0.16	1506	0.24	1695	0.34	1870	0.46	2029	0.58
1425	1366	0.18	1547	0.26	1729	0.36	1900	0.48	2057	0.61
1500	1420	0.20	1591	0.28	1765	0.38	1932	0.50	2087	0.63

CFM	AVAILABLE EXTERNAL STATIC PRESSURE (in. wg)									
	1.2		1.4		1.6		1.8		2.0	
	RPM	BHP	RPM	BHP	RPM	BHP	RPM	BHP	RPM	BHP
900	1996	0.55	2124	0.67	2242	0.78	2352	0.91	2455	1.03
975	2028	0.58	2157	0.70	2276	0.82	2387	0.95	—	—
1050	2058	0.61	2189	0.73	2309	0.86	2421	0.99	—	—
1125	2088	0.63	2219	0.76	2341	0.89	2454	1.03	—	—
1200	2117	0.66	2249	0.79	2372	0.93	2486	1.07	—	—
1275	2146	0.69	2278	0.82	2402	0.97	—	—	—	—
1350	2174	0.72	2307	0.86	2431	1.00	—	—	—	—
1425	2203	0.74	2336	0.89	2460	1.04	—	—	—	—
1500	2230	0.77	2364	0.92	2488	1.07	—	—	—	—

Standard Static 1137-1890 RPM, 0.44 Max BHP

Medium Static 1137-2190 RPM, 0.71 Max BHP

High Static 1137-2490 RPM, 1.07 Max BHP

50GCQM04 THREE PHASE - STANDARD STATIC — 3 TON HORIZONTAL SUPPLY (RPM - VDC)

CFM	AVAILABLE EXTERNAL STATIC PRESSURE (in. wg)									
	0.2		0.4		0.6		0.8		1.0	
	RPM	Vdc	RPM	Vdc	RPM	Vdc	RPM	Vdc	RPM	Vdc
900	1037	5.5	1301	6.9	1517	8.0	1698	9.0	1855	9.8
975	1076	5.7	1330	7.0	1545	8.2	1727	9.1	1886	10.0
1050	1119	5.9	1361	7.2	1574	8.3	1755	9.3	—	—
1125	1164	6.2	1394	7.4	1602	8.5	1784	9.4	—	—
1200	1212	6.4	1430	7.6	1632	8.6	1813	9.6	—	—
1275	1261	6.7	1466	7.8	1663	8.8	1840	9.7	—	—
1350	1313	6.9	1506	8.0	1695	9.0	1870	9.9	—	—
1425	1366	7.2	1547	8.2	1729	9.1	—	—	—	—
1500	1420	7.5	1591	8.4	1765	9.3	—	—	—	—

CFM	AVAILABLE EXTERNAL STATIC PRESSURE (in. wg)									
	1.2		1.4		1.6		1.8		2.0	
	RPM	Vdc	RPM	Vdc	RPM	Vdc	RPM	Vdc	RPM	Vdc
900	—	—	—	—	—	—	—	—	—	—
975	—	—	—	—	—	—	—	—	—	—
1050	—	—	—	—	—	—	—	—	—	—
1125	—	—	—	—	—	—	—	—	—	—
1200	—	—	—	—	—	—	—	—	—	—
1275	—	—	—	—	—	—	—	—	—	—
1350	—	—	—	—	—	—	—	—	—	—
1425	—	—	—	—	—	—	—	—	—	—
1500	—	—	—	—	—	—	—	—	—	—

Standard Static 1137-1890 RPM



50GCQM04 THREE PHASE - MEDIUM STATIC — 3 TON HORIZONTAL SUPPLY (RPM - VDC)

CFM	AVAILABLE EXTERNAL STATIC PRESSURE (in. wg)									
	0.2		0.4		0.6		0.8		1.0	
	RPM	Vdc	RPM	Vdc	RPM	Vdc	RPM	Vdc	RPM	Vdc
900	1037	4.7	1301	5.9	1517	6.9	1698	7.8	1855	8.5
975	1076	4.9	1330	6.1	1545	7.1	1727	7.9	1886	8.6
1050	1119	5.1	1361	6.2	1574	7.2	1755	8.0	1915	8.7
1125	1164	5.3	1394	6.4	1602	7.3	1784	8.1	1944	8.9
1200	1212	5.5	1430	6.5	1632	7.5	1813	8.3	1972	9.0
1275	1261	5.8	1466	6.7	1663	7.6	1840	8.4	2001	9.1
1350	1313	6.0	1506	6.9	1695	7.7	1870	8.5	2029	9.3
1425	1366	6.2	1547	7.1	1729	7.9	1900	8.7	2057	9.4
1500	1420	6.5	1591	7.3	1765	8.1	1932	8.8	2087	9.5

CFM	AVAILABLE EXTERNAL STATIC PRESSURE (in. wg)									
	1.2		1.4		1.6		1.8		2.0	
	RPM	Vdc	RPM	Vdc	RPM	Vdc	RPM	Vdc	RPM	Vdc
900	1996	9.1	2124	9.7	—	—	—	—	—	—
975	2028	9.3	2157	9.8	—	—	—	—	—	—
1050	2058	9.4	2189	10.0	—	—	—	—	—	—
1125	2088	9.5	—	—	—	—	—	—	—	—
1200	2117	9.7	—	—	—	—	—	—	—	—
1275	2146	9.8	—	—	—	—	—	—	—	—
1350	2174	9.9	—	—	—	—	—	—	—	—
1425	—	—	—	—	—	—	—	—	—	—
1500	—	—	—	—	—	—	—	—	—	—

Medium Static 1137-2190 RPM

50GCQM04 THREE PHASE - HIGH STATIC — 3 TON HORIZONTAL SUPPLY (RPM - VDC)

CFM	AVAILABLE EXTERNAL STATIC PRESSURE (in. wg)									
	0.2		0.4		0.6		0.8		1.0	
	RPM	Vdc	RPM	Vdc	RPM	Vdc	RPM	Vdc	RPM	Vdc
900	1037	4.2	1301	5.2	1517	6.1	1698	6.8	1855	7.4
975	1076	4.3	1330	5.3	1545	6.2	1727	6.9	1886	7.6
1050	1119	4.5	1361	5.5	1574	6.3	1755	7.0	1915	7.7
1125	1164	4.7	1394	5.6	1602	6.4	1784	7.2	1944	7.8
1200	1212	4.9	1430	5.7	1632	6.6	1813	7.3	1972	7.9
1275	1261	5.1	1466	5.9	1663	6.7	1840	7.4	2001	8.0
1350	1313	5.3	1506	6.0	1695	6.8	1870	7.5	2029	8.1
1425	1366	5.5	1547	6.2	1729	6.9	1900	7.6	2057	8.3
1500	1420	5.7	1591	6.4	1765	7.1	1932	7.8	2087	8.4

CFM	AVAILABLE EXTERNAL STATIC PRESSURE (in. wg)									
	1.2		1.4		1.6		1.8		2.0	
	RPM	Vdc	RPM	Vdc	RPM	Vdc	RPM	Vdc	RPM	Vdc
900	1996	8.0	2124	8.5	2242	9.0	2352	9.4	2455	9.9
975	2028	8.1	2157	8.7	2276	9.1	2387	9.6	—	—
1050	2058	8.3	2189	8.8	2309	9.3	2421	9.7	—	—
1125	2088	8.4	2219	8.9	2341	9.4	2454	9.9	—	—
1200	2117	8.5	2249	9.0	2372	9.5	2486	10.0	—	—
1275	2146	8.6	2278	9.1	2402	9.6	—	—	—	—
1350	2174	8.7	2307	9.3	2431	9.8	—	—	—	—
1425	2203	8.8	2336	9.4	2460	9.9	—	—	—	—
1500	2230	9.0	2364	9.5	2488	10.0	—	—	—	—

High Static 1137-2490 RPM

50GCQM05 SINGLE PHASE — 4 TON HORIZONTAL SUPPLY (RPM - BHP)

CFM	AVAILABLE EXTERNAL STATIC PRESSURE (in. wg)									
	0.2		0.4		0.6		0.8		1.0	
	RPM	BHP	RPM	BHP	RPM	BHP	RPM	BHP	RPM	BHP
1200	1021	0.11	1227	0.19	1417	0.30	1586	0.42	1738	0.55
1300	1073	0.13	1265	0.21	1447	0.31	1612	0.43	1762	0.57
1400	1128	0.15	1305	0.23	1479	0.33	1640	0.46	1788	0.59
1500	1185	0.17	1349	0.25	1514	0.36	1670	0.48	1815	0.61
1600	1244	0.20	1396	0.28	1553	0.38	1703	0.51	1844	0.64
1700	1304	0.23	1446	0.31	1593	0.41	1737	0.53	1875	0.67
1800	1365	0.26	1498	0.34	1636	0.45	1774	0.57	1907	0.71
1900	1427	0.29	1551	0.38	1681	0.48	1813	0.60	1942	0.74
2000	1490	0.33	1607	0.42	1730	0.52	1855	0.65	1978	0.78

CFM	AVAILABLE EXTERNAL STATIC PRESSURE (in. wg)									
	1.2		1.4		1.6		1.8		2.0	
	RPM	BHP	RPM	BHP	RPM	BHP	RPM	BHP	RPM	BHP
1200	1875	0.69	2003	0.84	2123	1.00	2237	1.17	2345	1.35
1300	1899	0.71	2026	0.86	2145	1.02	2258	1.19	2365	1.37
1400	1925	0.74	2050	0.89	2169	1.05	2280	1.22	2387	1.40
1500	1950	0.76	2076	0.92	2193	1.08	2304	1.26	2409	1.44
1600	1977	0.79	2101	0.95	2218	1.12	2328	1.29	2433	1.47
1700	2005	0.82	2127	0.98	2244	1.15	2353	1.33	2457	1.51
1800	2034	0.86	2155	1.02	2270	1.19	2379	1.37	—	—
1900	2066	0.89	2184	1.06	2297	1.23	2405	1.41	—	—
2000	2099	0.94	2215	1.10	2326	1.27	2432	1.45	—	—

Standard Static 1021-1900 RPM, 0.72 Max BHP

Medium Static 1021-2170 RPM, 1.06 Max BHP

High Static 1021-2460 RPM, 1.53 Max BHP

50GCQM05 SINGLE PHASE - STANDARD STATIC — 4 TON HORIZONTAL SUPPLY (RPM - VDC)

CFM	AVAILABLE EXTERNAL STATIC PRESSURE (in. wg)									
	0.2		0.4		0.6		0.8		1.0	
	RPM	Vdc	RPM	Vdc	RPM	Vdc	RPM	Vdc	RPM	Vdc
1200	1021	5.4	1227	6.5	1417	7.5	1586	8.3	1738	9.1
1300	1073	5.6	1265	6.7	1447	7.6	1612	8.5	1762	9.3
1400	1128	5.9	1305	6.9	1479	7.8	1640	8.6	1788	9.4
1500	1185	6.2	1349	7.1	1514	8.0	1670	8.8	1815	9.6
1600	1244	6.5	1396	7.3	1553	8.2	1703	9.0	1844	9.7
1700	1304	6.9	1446	7.6	1593	8.4	1737	9.1	1875	9.9
1800	1365	7.2	1498	7.9	1636	8.6	1774	9.3	—	—
1900	1427	7.5	1551	8.2	1681	8.8	1813	9.5	—	—
2000	1490	7.8	1607	8.5	1730	9.1	1855	9.8	—	—

CFM	AVAILABLE EXTERNAL STATIC PRESSURE (in. wg)									
	1.2		1.4		1.6		1.8		2.0	
	RPM	Vdc	RPM	Vdc	RPM	Vdc	RPM	Vdc	RPM	Vdc
1200	1875	9.9	—	—	—	—	—	—	—	—
1300	1899	10.0	—	—	—	—	—	—	—	—
1400	—	—	—	—	—	—	—	—	—	—
1500	—	—	—	—	—	—	—	—	—	—
1600	—	—	—	—	—	—	—	—	—	—
1700	—	—	—	—	—	—	—	—	—	—
1800	—	—	—	—	—	—	—	—	—	—
1900	—	—	—	—	—	—	—	—	—	—
2000	—	—	—	—	—	—	—	—	—	—

Standard Static 1021-1900 RPM



50GCQM05 SINGLE PHASE - MEDIUM STATIC — 4 TON HORIZONTAL SUPPLY (RPM - VDC)

CFM	AVAILABLE EXTERNAL STATIC PRESSURE (in. wg)									
	0.2		0.4		0.6		0.8		1.0	
	RPM	Vdc	RPM	Vdc	RPM	Vdc	RPM	Vdc	RPM	Vdc
1200	1021	4.7	1227	5.7	1417	6.5	1586	7.3	1738	8.0
1300	1073	4.9	1265	5.8	1447	6.7	1612	7.4	1762	8.1
1400	1128	5.2	1305	6.0	1479	6.8	1640	7.6	1788	8.2
1500	1185	5.5	1349	6.2	1514	7.0	1670	7.7	1815	8.4
1600	1244	5.7	1396	6.4	1553	7.2	1703	7.8	1844	8.5
1700	1304	6.0	1446	6.7	1593	7.3	1737	8.0	1875	8.6
1800	1365	6.3	1498	6.9	1636	7.5	1774	8.2	1907	8.8
1900	1427	6.6	1551	7.1	1681	7.7	1813	8.4	1942	8.9
2000	1490	6.9	1607	7.4	1730	8.0	1855	8.5	1978	9.1

CFM	AVAILABLE EXTERNAL STATIC PRESSURE (in. wg)									
	1.2		1.4		1.6		1.8		2.0	
	RPM	Vdc	RPM	Vdc	RPM	Vdc	RPM	Vdc	RPM	Vdc
1200	1875	8.6	2003	9.2	2123	9.8	—	—	—	—
1300	1899	8.8	2026	9.3	2145	9.9	—	—	—	—
1400	1925	8.9	2050	9.4	2169	10.0	—	—	—	—
1500	1950	9.0	2076	9.6	—	—	—	—	—	—
1600	1977	9.1	2101	9.7	—	—	—	—	—	—
1700	2005	9.2	2127	9.8	—	—	—	—	—	—
1800	2034	9.4	2155	9.9	—	—	—	—	—	—
1900	2066	9.5	—	—	—	—	—	—	—	—
2000	2099	9.7	—	—	—	—	—	—	—	—

Medium Static 1021-2170 RPM

50GCQM05 SINGLE PHASE - HIGH STATIC — 4 TON HORIZONTAL SUPPLY (RPM - VDC)

CFM	AVAILABLE EXTERNAL STATIC PRESSURE (in. wg)									
	0.2		0.4		0.6		0.8		1.0	
	RPM	Vdc	RPM	Vdc	RPM	Vdc	RPM	Vdc	RPM	Vdc
1200	1021	4.2	1227	5.0	1417	5.8	1586	6.4	1738	7.1
1300	1073	4.4	1265	5.1	1447	5.9	1612	6.6	1762	7.2
1400	1128	4.6	1305	5.3	1479	6.0	1640	6.7	1788	7.3
1500	1185	4.8	1349	5.5	1514	6.2	1670	6.8	1815	7.4
1600	1244	5.1	1396	5.7	1553	6.3	1703	6.9	1844	7.5
1700	1304	5.3	1446	5.9	1593	6.5	1737	7.1	1875	7.6
1800	1365	5.5	1498	6.1	1636	6.7	1774	7.2	1907	7.8
1900	1427	5.8	1551	6.3	1681	6.8	1813	7.4	1942	7.9
2000	1490	6.1	1607	6.5	1730	7.0	1855	7.5	1978	8.0

CFM	AVAILABLE EXTERNAL STATIC PRESSURE (in. wg)									
	1.2		1.4		1.6		1.8		2.0	
	RPM	Vdc	RPM	Vdc	RPM	Vdc	RPM	Vdc	RPM	Vdc
1200	1875	7.6	2003	8.1	2123	8.6	2237	9.1	2345	9.5
1300	1899	7.7	2026	8.2	2145	8.7	2258	9.2	2365	9.6
1400	1925	7.8	2050	8.3	2169	8.8	2280	9.3	2387	9.7
1500	1950	7.9	2076	8.4	2193	8.9	2304	9.4	2409	9.8
1600	1977	8.0	2101	8.5	2218	9.0	2328	9.5	2433	9.9
1700	2005	8.2	2127	8.6	2244	9.1	2353	9.6	2457	10.0
1800	2034	8.3	2155	8.8	2270	9.2	2379	9.7	—	—
1900	2066	8.4	2184	8.9	2297	9.3	2405	9.8	—	—
2000	2099	8.5	2215	9.0	2326	9.5	2432	9.9	—	—

High Static 1021-2460 RPM

50GCQM05 THREE PHASE — 4 TON HORIZONTAL SUPPLY (RPM - BHP)

CFM	AVAILABLE EXTERNAL STATIC PRESSURE (in. wg)									
	0.2		0.4		0.6		0.8		1.0	
	RPM	BHP	RPM	BHP	RPM	BHP	RPM	BHP	RPM	BHP
1200	1022	0.11	1228	0.19	1417	0.30	1586	0.42	1737	0.55
1300	1074	0.13	1265	0.21	1447	0.31	1613	0.44	1762	0.57
1400	1129	0.15	1306	0.23	1479	0.33	1641	0.46	1788	0.59
1500	1186	0.17	1350	0.25	1514	0.36	1671	0.48	1816	0.62
1600	1244	0.20	1397	0.28	1553	0.38	1703	0.51	1845	0.64
1700	1304	0.23	1446	0.31	1593	0.41	1737	0.53	1875	0.67
1800	1365	0.26	1498	0.34	1636	0.45	1774	0.57	1907	0.71
1900	1427	0.29	1552	0.38	1682	0.48	1814	0.61	1942	0.74
2000	1490	0.33	1607	0.42	1730	0.52	1855	0.65	1978	0.78

CFM	AVAILABLE EXTERNAL STATIC PRESSURE (in. wg)									
	1.2		1.4		1.6		1.8		2.0	
	RPM	BHP	RPM	BHP	RPM	BHP	RPM	BHP	RPM	BHP
1200	1875	0.69	2003	0.84	2123	1.00	2237	1.17	2345	1.35
1300	1899	0.71	2026	0.86	2145	1.02	2258	1.19	2365	1.37
1400	1924	0.74	2050	0.89	2169	1.05	2280	1.22	2387	1.40
1500	1950	0.76	2075	0.92	2193	1.08	2304	1.26	2409	1.44
1600	1977	0.79	2101	0.95	2218	1.12	2328	1.29	2433	1.47
1700	2005	0.82	2128	0.98	2243	1.15	2353	1.33	2457	1.51
1800	2035	0.86	2156	1.02	2270	1.19	2379	1.37	2482	1.55
1900	2066	0.89	2185	1.06	2298	1.23	2405	1.41	2508	1.60
2000	2099	0.94	2215	1.10	2326	1.27	2433	1.46	2535	1.65

Standard Static 1022-1900 RPM, 0.72 Max BHP

Medium Static 1022-2170 RPM, 1.06 Max BHP

High Static 1022-2660 RPM, 1.96 Max BHP

50GCQM05 THREE PHASE - STANDARD STATIC — 4 TON HORIZONTAL SUPPLY (RPM - VDC)

CFM	AVAILABLE EXTERNAL STATIC PRESSURE (in. wg)									
	0.2		0.4		0.6		0.8		1.0	
	RPM	Vdc	RPM	Vdc	RPM	Vdc	RPM	Vdc	RPM	Vdc
1200	1022	5.4	1228	6.5	1417	7.5	1586	8.3	1737	9.1
1300	1074	5.7	1265	6.7	1447	7.6	1613	8.5	1762	9.3
1400	1129	5.9	1306	6.9	1479	7.8	1641	8.6	1788	9.4
1500	1186	6.2	1350	7.1	1514	8.0	1671	8.8	1816	9.6
1600	1244	6.5	1397	7.4	1553	8.2	1703	9.0	1845	9.7
1700	1304	6.9	1446	7.6	1593	8.4	1737	9.1	1875	9.9
1800	1365	7.2	1498	7.9	1636	8.6	1774	9.3	—	—
1900	1427	7.5	1552	8.2	1682	8.9	1814	9.5	—	—
2000	1490	7.8	1607	8.5	1730	9.1	1855	9.8	—	—

CFM	AVAILABLE EXTERNAL STATIC PRESSURE (in. wg)									
	1.2		1.4		1.6		1.8		2.0	
	RPM	Vdc	RPM	Vdc	RPM	Vdc	RPM	Vdc	RPM	Vdc
1200	875	9.9	—	—	—	—	—	—	—	—
1300	1899	10.0	—	—	—	—	—	—	—	—
1400	—	—	—	—	—	—	—	—	—	—
1500	—	—	—	—	—	—	—	—	—	—
1600	—	—	—	—	—	—	—	—	—	—
1700	—	—	—	—	—	—	—	—	—	—
1800	—	—	—	—	—	—	—	—	—	—
1900	—	—	—	—	—	—	—	—	—	—
2000	—	—	—	—	—	—	—	—	—	—

Standard Static 1022-1900 RPM



50GCQM05 THREE PHASE - MEDIUM STATIC — 4 TON HORIZONTAL SUPPLY (RPM - VDC)

CFM	AVAILABLE EXTERNAL STATIC PRESSURE (in. wg)									
	0.2		0.4		0.6		0.8		1.0	
	RPM	Vdc	RPM	Vdc	RPM	Vdc	RPM	Vdc	RPM	Vdc
1200	1022	4.7	1228	5.7	1417	6.5	1586	7.3	1737	8.0
1300	1074	4.9	1265	5.8	1447	6.7	1613	7.4	1762	8.1
1400	1129	5.2	1306	6.0	1479	6.8	1641	7.6	1788	8.2
1500	1186	5.5	1350	6.2	1514	7.0	1671	7.7	1816	8.4
1600	1244	5.7	1397	6.4	1553	7.2	1703	7.8	1845	8.5
1700	1304	6.0	1446	6.7	1593	7.3	1737	8.0	1875	8.6
1800	1365	6.3	1498	6.9	1636	7.5	1774	8.2	1907	8.8
1900	1427	6.6	1552	7.2	1682	7.8	1814	8.4	1942	8.9
2000	1490	6.9	1607	7.4	1730	8.0	1855	8.5	1978	9.1

CFM	AVAILABLE EXTERNAL STATIC PRESSURE (in. wg)									
	1.2		1.4		1.6		1.8		2.0	
	RPM	Vdc	RPM	Vdc	RPM	Vdc	RPM	Vdc	RPM	Vdc
1200	1875	8.6	2003	9.2	2123	9.8	—	—	—	—
1300	1899	8.8	2026	9.3	2145	9.9	—	—	—	—
1400	1924	8.9	2050	9.4	2169	10.0	—	—	—	—
1500	1950	9.0	2075	9.6	—	—	—	—	—	—
1600	1977	9.1	2101	9.7	—	—	—	—	—	—
1700	2005	9.2	2128	9.8	—	—	—	—	—	—
1800	2035	9.4	2156	9.9	—	—	—	—	—	—
1900	2066	9.5	—	—	—	—	—	—	—	—
2000	2099	9.7	—	—	—	—	—	—	—	—

Medium Static 1022-2170 RPM

50GCQM05 THREE PHASE - HIGH STATIC — 4 TON HORIZONTAL SUPPLY (RPM - VDC)

CFM	AVAILABLE EXTERNAL STATIC PRESSURE (in. wg)									
	0.2		0.4		0.6		0.8		1.0	
	RPM	Vdc	RPM	Vdc	RPM	Vdc	RPM	Vdc	RPM	Vdc
1200	1022	3.8	1228	4.6	1417	5.3	1586	6.0	1737	6.5
1300	1074	4.0	1265	4.8	1447	5.4	1613	6.1	1762	6.6
1400	1129	4.2	1306	4.9	1479	5.6	1641	6.2	1788	6.7
1500	1186	4.5	1350	5.1	1514	5.7	1671	6.3	1816	6.8
1600	1244	4.7	1397	5.3	1553	5.8	1703	6.4	1845	6.9
1700	1304	4.9	1446	5.4	1593	6.0	1737	6.5	1875	7.0
1800	1365	5.1	1498	5.6	1636	6.2	1774	6.7	1907	7.2
1900	1427	5.4	1552	5.8	1682	6.3	1814	6.8	1942	7.3
2000	1490	5.6	1607	6.0	1730	6.5	1855	7.0	1978	7.4

CFM	AVAILABLE EXTERNAL STATIC PRESSURE (in. wg)									
	1.2		1.4		1.6		1.8		2.0	
	RPM	Vdc	RPM	Vdc	RPM	Vdc	RPM	Vdc	RPM	Vdc
1200	1875	7.0	2003	7.5	2123	8.0	2237	8.4	2345	8.8
1300	1899	7.1	2026	7.6	2145	8.1	2258	8.5	2365	8.9
1400	1924	7.2	2050	7.7	2169	8.2	2280	8.6	2387	9.0
1500	1950	7.3	2075	7.8	2193	8.2	2304	8.7	2409	9.1
1600	1977	7.4	2101	7.9	2218	8.3	2328	8.8	2433	9.1
1700	2005	7.5	2128	8.0	2243	8.4	2353	8.8	2457	9.2
1800	2035	7.7	2156	8.1	2270	8.5	2379	8.9	2482	9.3
1900	2066	7.8	2185	8.2	2298	8.6	2405	9.0	2508	9.4
2000	2099	7.9	2215	8.3	2326	8.7	2433	9.1	2535	9.5

High Static 1022-2660 RPM

50GCQM06 SINGLE PHASE — 5 TON HORIZONTAL SUPPLY (RPM - BHP)

CFM	AVAILABLE EXTERNAL STATIC PRESSURE (in. wg)									
	0.2		0.4		0.6		0.8		1.0	
	RPM	BHP	RPM	BHP	RPM	BHP	RPM	BHP	RPM	BHP
1500	1197	0.18	1361	0.26	1524	0.36	1679	0.49	1822	0.62
1625	1271	0.21	1421	0.29	1574	0.40	1721	0.52	1860	0.66
1750	1347	0.25	1485	0.33	1627	0.44	1767	0.56	1901	0.70
1875	1425	0.29	1553	0.38	1684	0.49	1817	0.61	1945	0.75
2000	1504	0.35	1623	0.43	1745	0.54	1870	0.66	1992	0.80
2125	1585	0.40	1695	0.49	1809	0.60	1926	0.72	2043	0.86
2250	1666	0.47	1769	0.56	1876	0.67	1986	0.79	2096	0.93
2375	1747	0.54	1844	0.63	1945	0.74	2049	0.87	2153	1.01
2500	1830	0.62	1921	0.71	2016	0.82	2114	0.95	2213	1.09

CFM	AVAILABLE EXTERNAL STATIC PRESSURE (in. wg)									
	1.2		1.4		1.6		1.8		2.0	
	RPM	BHP	RPM	BHP	RPM	BHP	RPM	BHP	RPM	BHP
1500	1954	0.77	2078	0.92	2194	1.09	2304	1.26	2408	1.44
1625	1990	0.81	2112	0.97	2227	1.13	2336	1.31	2439	1.49
1750	2028	0.85	2148	1.01	2262	1.18	2370	1.36	2472	1.54
1875	2068	0.90	2186	1.06	2298	1.23	2404	1.41	2506	1.60
2000	2111	0.95	2226	1.12	2336	1.29	2441	1.48	2541	1.66
2125	2157	1.02	2268	1.18	2375	1.36	2478	1.54	2578	1.73
2250	2206	1.08	2313	1.25	2417	1.43	2518	1.61	2616	1.81
2375	2257	1.16	2361	1.33	2461	1.50	2560	1.69	2655	1.89
2500	2312	1.24	2411	1.41	2508	1.59	2604	1.78	—	—

Standard Static 1197-2150 RPM, 1.06 Max BHP

Medium Static 1197-2390 RPM, 1.44 Max BHP

High Static 1197-2660 RPM, 1.96 Max BHP

50GCQM06 SINGLE PHASE - STANDARD STATIC — 5 TON HORIZONTAL SUPPLY (RPM - VDC)

CFM	AVAILABLE EXTERNAL STATIC PRESSURE (in. wg)									
	0.2		0.4		0.6		0.8		1.0	
	RPM	Vdc	RPM	Vdc	RPM	Vdc	RPM	Vdc	RPM	Vdc
1500	1197	5.6	1361	6.3	1524	7.1	1679	7.8	1822	8.5
1625	1271	5.9	1421	6.6	1574	7.3	1721	8.0	1860	8.7
1750	1347	6.3	1485	6.9	1627	7.6	1767	8.2	1901	8.8
1875	1425	6.6	1553	7.2	1684	7.8	1817	8.5	1945	9.0
2000	1504	7.0	1623	7.5	1745	8.1	1870	8.7	1992	9.3
2125	1585	7.4	1695	7.9	1809	8.4	1926	9.0	2043	9.5
2250	1666	7.7	1769	8.2	1876	8.7	1986	9.2	2096	9.7
2375	1747	8.1	1844	8.6	1945	9.0	2049	9.5	—	—
2500	1830	8.5	1921	8.9	2016	9.4	2114	9.8	—	—

CFM	AVAILABLE EXTERNAL STATIC PRESSURE (in. wg)									
	1.2		1.4		1.6		1.8		2.0	
	RPM	Vdc	RPM	Vdc	RPM	Vdc	RPM	Vdc	RPM	Vdc
1500	1954	9.1	2078	9.7	—	—	—	—	—	—
1625	1990	9.3	2112	9.8	—	—	—	—	—	—
1750	2028	9.4	2148	10.0	—	—	—	—	—	—
1875	2068	9.6	—	—	—	—	—	—	—	—
2000	2111	9.8	—	—	—	—	—	—	—	—
2125	—	—	—	—	—	—	—	—	—	—
2250	—	—	—	—	—	—	—	—	—	—
2375	—	—	—	—	—	—	—	—	—	—
2500	—	—	—	—	—	—	—	—	—	—

Standard Static 1197-2150 RPM

50GCQM06 SINGLE PHASE - MEDIUM STATIC — 5 TON HORIZONTAL SUPPLY (RPM - VDC)

CFM	AVAILABLE EXTERNAL STATIC PRESSURE (in. wg)									
	0.2		0.4		0.6		0.8		1.0	
	RPM	Vdc	RPM	Vdc	RPM	Vdc	RPM	Vdc	RPM	Vdc
1500	1197	5.0	1361	5.7	1524	6.4	1679	7.0	1822	7.6
1625	1271	5.3	1421	5.9	1574	6.6	1721	7.2	1860	7.8
1750	1347	5.6	1485	6.2	1627	6.8	1767	7.4	1901	8.0
1875	1425	6.0	1553	6.5	1684	7.0	1817	7.6	1945	8.1
2000	1504	6.3	1623	6.8	1745	7.3	1870	7.8	1992	8.3
2125	1585	6.6	1695	7.1	1809	7.6	1926	8.1	2043	8.5
2250	1666	7.0	1769	7.4	1876	7.8	1986	8.3	2096	8.8
2375	1747	7.3	1844	7.7	1945	8.1	2049	8.6	2153	9.0
2500	1830	7.7	1921	8.0	2016	8.4	2114	8.8	2213	9.3

CFM	AVAILABLE EXTERNAL STATIC PRESSURE (in. wg)									
	1.2		1.4		1.6		1.8		2.0	
	RPM	Vdc	RPM	Vdc	RPM	Vdc	RPM	Vdc	RPM	Vdc
1500	1954	8.2	2078	8.7	2194	9.2	2304	9.6	—	—
1625	1990	8.3	2112	8.8	2227	9.3	2336	9.8	—	—
1750	2028	8.5	2148	9.0	2262	9.5	2370	9.9	—	—
1875	2068	8.7	2186	9.1	2298	9.6	—	—	—	—
2000	2111	8.8	2226	9.3	2336	9.8	—	—	—	—
2125	2157	9.0	2268	9.5	2375	9.9	—	—	—	—
2250	2206	9.2	2313	9.7	—	—	—	—	—	—
2375	2257	9.4	2361	9.9	—	—	—	—	—	—
2500	2312	9.7	—	—	—	—	—	—	—	—

Medium Static 1197-2390 RPM

50GCQM06 SINGLE PHASE - HIGH STATIC — 5 TON HORIZONTAL SUPPLY (RPM - VDC)

CFM	AVAILABLE EXTERNAL STATIC PRESSURE (in. wg)									
	0.2		0.4		0.6		0.8		1.0	
	RPM	Vdc	RPM	Vdc	RPM	Vdc	RPM	Vdc	RPM	Vdc
1500	1197	4.5	1361	5.1	1524	5.7	1679	6.3	1822	6.8
1625	1271	4.8	1421	5.3	1574	5.9	1721	6.5	1860	7.0
1750	1347	5.1	1485	5.6	1627	6.1	1767	6.6	1901	7.1
1875	1425	5.4	1553	5.8	1684	6.3	1817	6.8	1945	7.3
2000	1504	5.7	1623	6.1	1745	6.6	1870	7.0	1992	7.5
2125	1585	6.0	1695	6.4	1809	6.8	1926	7.2	2043	7.7
2250	1666	6.3	1769	6.7	1876	7.1	1986	7.5	2096	7.9
2375	1747	6.6	1844	6.9	1945	7.3	2049	7.7	2153	8.1
2500	1830	6.9	1921	7.2	2016	7.6	2114	7.9	2213	8.3

CFM	AVAILABLE EXTERNAL STATIC PRESSURE (in. wg)									
	1.2		1.4		1.6		1.8		2.0	
	RPM	Vdc	RPM	Vdc	RPM	Vdc	RPM	Vdc	RPM	Vdc
1500	1954	7.3	2078	7.8	2194	8.2	2304	8.7	2408	9.1
1625	1990	7.5	2112	7.9	2227	8.4	2336	8.8	2439	9.2
1750	2028	7.6	2148	8.1	2262	8.5	2370	8.9	2472	9.3
1875	2068	7.8	2186	8.2	2298	8.6	2404	9.0	2506	9.4
2000	2111	7.9	2226	8.4	2336	8.8	2441	9.2	2541	9.6
2125	2157	8.1	2268	8.5	2375	8.9	2478	9.3	2578	9.7
2250	2206	8.3	2313	8.7	2417	9.1	2518	9.5	2616	9.8
2375	2257	8.5	2361	8.9	2461	9.3	2560	9.6	2655	10.0
2500	2312	8.7	2411	9.1	2508	9.4	2604	9.8	—	—

High Static 1197-2660 RPM

50GCQM06 THREE PHASE — 5 TON HORIZONTAL SUPPLY (RPM - BHP)

CFM	AVAILABLE EXTERNAL STATIC PRESSURE (in. wg)									
	0.2		0.4		0.6		0.8		1.0	
	RPM	BHP	RPM	BHP	RPM	BHP	RPM	BHP	RPM	BHP
1500	1197	0.18	1361	0.26	1524	0.36	1679	0.49	1822	0.62
1625	1271	0.21	1421	0.29	1574	0.40	1721	0.52	1860	0.66
1750	1347	0.25	1485	0.33	1627	0.44	1767	0.56	1901	0.70
1875	1425	0.29	1553	0.38	1684	0.49	1817	0.61	1945	0.75
2000	1504	0.35	1623	0.43	1745	0.54	1870	0.66	1992	0.80
2125	1584	0.40	1695	0.49	1809	0.60	1926	0.72	2043	0.86
2250	1665	0.47	1769	0.56	1876	0.67	1986	0.79	2096	0.93
2375	1747	0.54	1844	0.63	1945	0.74	2049	0.87	2153	1.01
2500	1830	0.62	1921	0.71	2016	0.82	2114	0.95	2213	1.09

CFM	AVAILABLE EXTERNAL STATIC PRESSURE (in. wg)									
	1.2		1.4		1.6		1.8		2.0	
	RPM	BHP	RPM	BHP	RPM	BHP	RPM	BHP	RPM	BHP
1500	1954	0.77	2078	0.92	2194	1.09	2304	1.26	2408	1.44
1625	1990	0.81	2112	0.97	2227	1.13	2336	1.31	2439	1.49
1750	2028	0.85	2148	1.01	2262	1.18	2370	1.36	2472	1.54
1875	2068	0.90	2186	1.06	2298	1.23	2404	1.41	2506	1.60
2000	2111	0.95	2226	1.12	2336	1.29	2441	1.48	2541	1.66
2125	2157	1.02	2268	1.18	2375	1.36	2478	1.54	2578	1.73
2250	2206	1.08	2313	1.25	2417	1.43	2518	1.61	2616	1.81
2375	2257	1.16	2361	1.33	2461	1.50	2560	1.69	2655	1.89
2500	2312	1.24	2411	1.41	2508	1.59	2604	1.78	2697	1.97

Standard Static 1197-2150 RPM, 1.06 Max BHP

Medium Static 1197-2390 RPM, 1.44 Max BHP

High Static 1197-2836 RPM, 2.43 Max BHP

50GCQM06 THREE PHASE - STANDARD STATIC — 5 TON HORIZONTAL SUPPLY (RPM - VDC)

CFM	AVAILABLE EXTERNAL STATIC PRESSURE (in. wg)									
	0.2		0.4		0.6		0.8		1.0	
	RPM	Vdc	RPM	Vdc	RPM	Vdc	RPM	Vdc	RPM	Vdc
1500	1197	5.6	1361	6.3	1524	7.1	1679	7.8	1822	8.5
1625	1271	5.9	1421	6.6	1574	7.3	1721	8.0	1860	8.7
1750	1347	6.3	1485	6.9	1627	7.6	1767	8.2	1901	8.8
1875	1425	6.6	1553	7.2	1684	7.8	1817	8.5	1945	9.0
2000	1504	7.0	1623	7.5	1745	8.1	1870	8.7	1992	9.3
2125	1584	7.4	1695	7.9	1809	8.4	1926	9.0	2043	9.5
2250	1665	7.7	1769	8.2	1876	8.7	1986	9.2	2096	9.7
2375	1747	8.1	1844	8.6	1945	9.0	2049	9.5	—	—
2500	1830	8.5	1921	8.9	2016	9.4	2114	9.8	—	—

CFM	AVAILABLE EXTERNAL STATIC PRESSURE (in. wg)									
	1.2		1.4		1.6		1.8		2.0	
	RPM	Vdc	RPM	Vdc	RPM	Vdc	RPM	Vdc	RPM	Vdc
1500	1954	9.1	2078	9.7	—	—	—	—	—	—
1625	1990	9.3	2112	9.8	—	—	—	—	—	—
1750	2028	9.4	2148	10.0	—	—	—	—	—	—
1875	2068	9.6	—	—	—	—	—	—	—	—
2000	2111	9.8	—	—	—	—	—	—	—	—
2125	—	—	—	—	—	—	—	—	—	—
2250	—	—	—	—	—	—	—	—	—	—
2375	—	—	—	—	—	—	—	—	—	—
2500	—	—	—	—	—	—	—	—	—	—

Standard Static 1197-2150 RPM

50GCQM06 THREE PHASE - MEDIUM STATIC — 5 TON HORIZONTAL SUPPLY (RPM - VDC)

CFM	AVAILABLE EXTERNAL STATIC PRESSURE (in. wg)									
	0.2		0.4		0.6		0.8		1.0	
	RPM	Vdc	RPM	Vdc	RPM	Vdc	RPM	Vdc	RPM	Vdc
1500	1197	5.0	1361	5.7	1524	6.4	1679	7.0	1822	7.6
1625	1271	5.3	1421	5.9	1574	6.6	1721	7.2	1860	7.8
1750	1347	5.6	1485	6.2	1627	6.8	1767	7.4	1901	8.0
1875	1425	6.0	1553	6.5	1684	7.0	1817	7.6	1945	8.1
2000	1504	6.3	1623	6.8	1745	7.3	1870	7.8	1992	8.3
2125	1584	6.6	1695	7.1	1809	7.6	1926	8.1	2043	8.5
2250	1665	7.0	1769	7.4	1876	7.8	1986	8.3	2096	8.8
2375	1747	7.3	1844	7.7	1945	8.1	2049	8.6	2153	9.0
2500	1830	7.7	1921	8.0	2016	8.4	2114	8.8	2213	9.3

CFM	AVAILABLE EXTERNAL STATIC PRESSURE (in. wg)									
	1.2		1.4		1.6		1.8		2.0	
	RPM	Vdc	RPM	Vdc	RPM	Vdc	RPM	Vdc	RPM	Vdc
1500	1954	8.2	2078	8.7	2194	9.2	2304	9.6	—	—
1625	1990	8.3	2112	8.8	2227	9.3	2336	9.8	—	—
1750	2028	8.5	2148	9.0	2262	9.5	2370	9.9	—	—
1875	2068	8.7	2186	9.1	2298	9.6	—	—	—	—
2000	2111	8.8	2226	9.3	2336	9.8	—	—	—	—
2125	2157	9.0	2268	9.5	2375	9.9	—	—	—	—
2250	2206	9.2	2313	9.7	—	—	—	—	—	—
2375	2257	9.4	2361	9.9	—	—	—	—	—	—
2500	2312	9.7	—	—	—	—	—	—	—	—

Medium Static 1197-2390 RPM

50GCQM06 THREE PHASE - HIGH STATIC — 5 TON HORIZONTAL SUPPLY (RPM - VDC)

CFM	AVAILABLE EXTERNAL STATIC PRESSURE (in. wg)									
	0.2		0.4		0.6		0.8		1.0	
	RPM	Vdc	RPM	Vdc	RPM	Vdc	RPM	Vdc	RPM	Vdc
1500	1197	4.2	1361	4.8	1524	5.4	1679	5.9	1822	6.4
1625	1271	4.5	1421	5.0	1574	5.6	1721	6.1	1860	6.6
1750	1347	4.7	1485	5.2	1627	5.7	1767	6.2	1901	6.7
1875	1425	5.0	1553	5.5	1684	5.9	1817	6.4	1945	6.9
2000	1504	5.3	1623	5.7	1745	6.2	1870	6.6	1992	7.0
2125	1584	5.6	1695	6.0	1809	6.4	1926	6.8	2043	7.2
2250	1665	5.9	1769	6.2	1876	6.6	1986	7.0	2096	7.4
2375	1747	6.2	1844	6.5	1945	6.9	2049	7.2	2153	7.6
2500	1830	6.5	1921	6.8	2016	7.1	2114	7.5	2213	7.8

CFM	AVAILABLE EXTERNAL STATIC PRESSURE (in. wg)									
	1.2		1.4		1.6		1.8		2.0	
	RPM	Vdc	RPM	Vdc	RPM	Vdc	RPM	Vdc	RPM	Vdc
1500	1954	6.9	2078	7.3	2194	7.7	2304	8.1	2408	8.5
1625	1990	7.0	2112	7.4	2227	7.9	2336	8.2	2439	8.6
1750	2028	7.2	2148	7.6	2262	8.0	2370	8.4	2472	8.7
1875	2068	7.3	2186	7.7	2298	8.1	2404	8.5	2506	8.8
2000	2111	7.4	2226	7.8	2336	8.2	2441	8.6	2541	9.0
2125	2157	7.6	2268	8.0	2375	8.4	2478	8.7	2578	9.1
2250	2206	7.8	2313	8.2	2417	8.5	2518	8.9	2616	9.2
2375	2257	8.0	2361	8.3	2461	8.7	2560	9.0	2655	9.4
2500	2312	8.2	2411	8.5	2508	8.8	2604	9.2	2697	9.5

High Static 1197-2836 RPM

Legend and Notes

Applicable for Electrical Data Tables on pages 55 to 79

LEGEND

BRKR	— Circuit Breaker
C.O.	— Convenience Outlet
FLA	— Full Load Amps
IFM	— Indoor Fan Motor
LRA	— Locked Rotor Amps
MCA	— Minimum Circuit Amps
P.E.	— Power Exhaust
Pwr'd fr/unit	— Powered From Unit
PWRD C.O.	— Powered Convenience Outlet
RLA	— Rated Load Amps
UNPWR C.O.	— Unpowered Convenience Outlet

NOTES:

1. In compliance with NEC requirements for multi-motor and combination load equipment (refer to NEC Articles 430 and 440), the overcurrent protective device for the unit shall be fuse or HACR breaker. Canadian units may be fuse or circuit breaker.
2. For 208/230 v units, where one value is show it is the same for either 208 or 230 volts.
3. **Unbalanced 3-Phase Supply Voltage**
Never operate a motor where a phase imbalance in supply voltage is greater than 2%. Use the following formula to determine the percentage of voltage imbalance.

$$\% \text{ Voltage Imbalance} = 100 \times \frac{\text{max voltage deviation from average voltage}}{\text{average voltage}}$$

Example: Supply voltage is 230-3-60

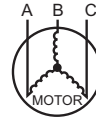

AB = 224 v
BC = 231 v
AC = 226 v

$$\begin{aligned} \text{Average Voltage} &= \frac{(224 + 231 + 226)}{3} = \frac{681}{3} \\ &= 227 \end{aligned}$$

Determine maximum deviation from average voltage.

(AB) 227 – 224 = 3 v
(BC) 231 – 227 = 4 v
(AC) 227 – 226 = 1 v

Maximum deviation is 4 v.

Determine percent of voltage imbalance.

$$\begin{aligned} \% \text{ Voltage Imbalance} &= 100 \times \frac{4}{227} \\ &= 1.76\% \end{aligned}$$

This amount of phase imbalance is satisfactory as it is below the maximum allowable 2%.

IMPORTANT: If the supply voltage phase imbalance is more than 2%, contact your local electric utility company immediately.

50GCQM04-06 COOLING ELECTRICAL DATA

50GCQ UNIT	V-Ph-Hz	UNIT VOLTAGE		COMPRESSOR		OFM (EA)		IFM			POWER EXHAUST	
		RANGE		RLA	LRA	WATTS	FLA	TYPE	EFFICIENCY AT FULL LOAD	FLA	KIT QTY	FLA (EA KIT)
		MIN	MAX									
M04	208-1-60	187	253	15.1	84	275	1.5	STD	84%	3.4	1	1.9
								MED	84%	5.1		
								HIGH	85%	7.3		
	230-1-60	187	253	15.1	84	275	1.5	STD	84%	3.4	1	1.9
								MED	84%	5.1		
								HIGH	85%	7.3		
	208-3-60	187	253	11.8	73	275	1.5	STD	84%	3.4	1	1.9
								MED	84%	5.1		
								HIGH	85%	7.3		
	230-3-60	187	253	11.8	73	275	1.5	STD	84%	3.4	1	1.9
								MED	84%	5.1		
								HIGH	85%	7.3		
	460-3-60	414	506	5.8	38	275	0.8	STD	85%	0.9	1	1.0
								MED	85%	1.2		
								HIGH	84%	1.5		
	575-3-60	518	633	4.1	26	275	0.6	STD	84%	0.8	1	1.9
								MED	84%	1.1		
								HIGH	85%	1.5		
M05	208-1-60	187	253	20.4	122	275	1.5	STD	87%	5.0	1	1.9
								MED	86%	7.1		
								HIGH	84%	8.8		
	230-1-60	187	253	20.4	122	275	1.5	STD	87%	5.0	1	1.9
								MED	86%	7.1		
								HIGH	84%	8.8		
	208-3-60	187	253	14.0	83	275	1.5	STD	87%	5.0	1	1.9
								MED	86%	7.1		
								HIGH	85%	5.1		
	230-3-60	187	253	14.0	83	275	1.5	STD	87%	5.0	1	1.9
								MED	86%	7.1		
								HIGH	85%	5.1		
	460-3-60	414	506	8.2	41	275	0.8	STD	85%	1.2	1	1.0
								MED	86%	1.5		
								HIGH	88%	2.4		
	575-3-60	518	633	4.6	33	275	0.6	STD	84%	1.1	1	1.9
								MED	85%	1.5		
								HIGH	88%	2.1		
M06	208-1-60	187	253	24.6	147	275	1.5	STD	86%	7.2	1	1.9
								MED	84%	8.6		
								HIGH	87%	8.1		
	230-1-60	187	253	24.6	147	275	1.5	STD	86%	7.2	1	1.9
								MED	84%	8.6		
								HIGH	87%	8.1		
	208-3-60	187	253	16.5	110	275	1.5	STD	86%	7.2	1	1.9
								MED	84%	8.6		
								HIGH	84%	6.4		
	230-3-60	187	253	16.5	110	275	1.5	STD	86%	7.2	1	1.9
								MED	84%	8.6		
								HIGH	84%	6.4		
	460-3-60	414	506	11.0	52	275	0.8	STD	86%	1.5	1	1.0
								MED	86%	1.9		
								HIGH	88%	2.9		
	575-3-60	518	633	8.3	39	275	0.6	STD	84%	1.5	1	1.9
								MED	85%	1.8		
								HIGH	87%	2.5		

50GCQM04 MCA MOCP ELECTRICAL DATA

50GCQ UNIT SIZE	NOM. V-Ph-Hz	IFM TYPE	ELECTRIC HEATER			NO CONVENIENCE OUTLET or UNPOWERED CONVENIENCE OUTLET							
			CRHEATER ****00	NOM (kW)	FLA	NO POWER EXHAUST				w/ POWER EXHAUST (powered from unit)			
						MCA	FUSE OR HACR BRKR	DISCONNECT SIZE		MCA	FUSE OR HACR BRKR	DISCONNECT SIZE	
							FLA	LRA			FLA	LRA	
M04	208/230-1-60	STD	NONE	—	—	24	30	23	93	26	30	25	95
			323A	3.3/4.4	15.9/18.3	44/47	50/50	41/44	109/111	46/49	50/50	43/46	111/113
			324A	4.9/6.5	23.5/27.1	54/58	60/60	50/54	117/120	56/60	60/60	52/56	119/122
			325A	6.5/8.7	31.4/36.3	63/70	70/70	59/65	124/129	65/72	70/80	61/67	126/131
			326A	7.9/10.5	37.9/43.8	72/79	80/80	67/73	131/137	74/81	80/90	69/76	133/139
		327A	9.8/13.0	46.9/54.2	83/92	90/100	77/85	140/147	85/94	90/100	79/88	142/149	
		MED	NONE	—	—	26	30	25	95	28	40	27	97
			323A	3.3/4.4	15.9/18.3	46/49	50/50	43/46	111/113	48/51	50/60	45/48	113/115
			324A	4.9/6.5	23.5/27.1	55/60	60/60	52/56	119/122	57/62	60/70	54/58	121/124
			325A	6.5/8.7	31.4/36.3	65/71	70/80	61/67	126/131	67/73	70/80	63/69	128/133
			326A	7.9/10.5	37.9/43.8	73/81	80/90	69/75	133/139	75/83	80/90	71/78	135/141
		HIGH	NONE	—	—	28	40	27	98	30	40	30	100
	323A		3.3/4.4	15.9/18.3	48/51	50/60	46/49	114/116	50/53	60/60	48/51	116/118	
	324A		4.9/6.5	23.5/27.1	58/62	60/70	55/59	122/125	59/64	60/70	57/61	124/127	
	325A		6.5/8.7	31.4/36.3	67/74	70/80	64/69	129/134	69/75	70/80	66/71	131/136	
	326A		7.9/10.5	37.9/43.8	76/83	80/90	71/78	136/142	77/85	80/90	73/80	138/144	
	208/230-3-60	STD	NONE	—	—	20	30	19	82	22	30	21	84
			323A	3.3/4.4	9.2/10.6	32/33	40/40	30/31	91/93	34/35	40/40	32/34	93/95
			324A	4.9/6.5	13.6/15.6	37/40	45/45	35/37	96/98	39/42	45/45	37/39	98/100
			325A	6.5/8.7	18.1/20.9	43/46	45/50	40/43	100/103	45/48	50/50	42/45	102/105
			326A	7.9/10.5	21.9/25.3	47/52	50/60	44/48	104/107	49/54	50/60	47/50	106/109
		328A	12.0/16.0	33.4/38.5	62/68	70/70	58/63	115/121	64/70	70/70	60/66	117/123	
		MED	NONE	—	—	22	30	21	84	24	30	23	86
			323A	3.3/4.4	9.2/10.6	33/35	40/40	32/33	93/95	35/37	40/45	34/36	95/97
			324A	4.9/6.5	13.6/15.6	39/41	45/45	37/39	98/100	41/43	45/50	39/41	100/102
			325A	6.5/8.7	18.1/20.9	44/48	50/50	42/45	102/105	46/50	50/50	44/47	104/107
			326A	7.9/10.5	21.9/25.3	49/53	50/60	46/50	106/109	51/55	60/60	49/52	108/111
		HIGH	NONE	—	—	24	30	24	87	26	30	26	89
	323A		3.3/4.4	9.2/10.6	36/37	40/45	34/36	96/98	37/39	45/45	36/38	98/100	
	324A		4.9/6.5	13.6/15.6	41/44	45/50	39/42	101/103	43/45	50/50	42/44	103/105	
	325A		6.5/8.7	18.1/20.9	47/50	50/50	45/48	105/108	49/52	50/60	47/50	107/110	
	326A		7.9/10.5	21.9/25.3	51/56	60/60	49/53	109/112	53/58	60/60	51/55	111/114	
	460-3-60	STD	NONE	—	—	9	15	9	41	10	15	10	42
			333A	6.0	7.2	18	20	17	48	19	20	18	49
			334A	8.8	10.6	23	25	21	52	24	25	22	53
			335A	11.5	13.8	27	30	24	55	28	30	26	56
336A			14.0	16.8	30	30	28	58	31	35	29	59	
MED		NONE	—	—	10	15	9	42	11	15	10	43	
		333A	6.0	7.2	19	20	17	49	20	20	18	50	
		334A	8.8	10.6	23	25	21	53	24	25	22	54	
		335A	11.5	13.8	27	30	25	56	28	30	26	57	
		336A	14.0	16.8	31	35	28	59	32	35	29	60	
HIGH		NONE	—	—	10	15	9	42	11	15	10	43	
		333A	6.0	7.2	19	20	18	49	20	20	19	50	
	334A	8.8	10.6	23	25	22	53	24	25	23	54		
	335A	11.5	13.8	27	30	25	56	28	30	26	57		
	336A	14.0	16.8	31	35	29	59	32	35	30	60		
575-3-60	STD	NONE	—	—	7	15	6	29	9	15	9	31	
		339A	10.0	9.6	19	20	17	39	21	25	20	41	
		340A	15.0	14.4	25	25	23	43	27	30	25	45	
	MED	NONE	—	—	7	15	7	30	9	15	9	32	
		339A	10.0	9.6	19	20	18	40	21	25	20	42	
		340A	15.0	14.4	25	25	23	44	27	30	25	46	
	HIGH	NONE	—	—	8	15	7	30	10	15	9	32	
		339A	10.0	9.6	20	20	18	40	22	25	20	42	
		340A	15.0	14.4	26	30	24	44	28	30	26	46	



50GCQM04 MCA MOCP ELECTRICAL DATA (cont)

50GCQ UNIT SIZE	NOM. V-Ph-Hz	IFM TYPE	ELECTRIC HEATER			w/ POWERED CONVENIENCE OUTLET								
			CRHEATER ****00	NOM (kW)	FLA	NO POWER EXHAUST				w/ POWER EXHAUST (powered from unit)				
						MCA	FUSE OR HACR BRKR	DISCONNECT SIZE		MCA	FUSE OR HACR BRKR	DISCONNECT SIZE		
							FLA	LRA			FLA	LRA		
M04	208/230-1-60	STD	NONE	—	—	—	—	—	—	—	—	—	—	—
			323A	3.3/4.4	15.9/18.3	—	—	—	—	—	—	—	—	—
			324A	4.9/6.5	23.5/27.1	—	—	—	—	—	—	—	—	—
			325A	6.5/8.7	31.4/36.3	—	—	—	—	—	—	—	—	—
			326A	7.9/10.5	37.9/43.8	—	—	—	—	—	—	—	—	—
		327A	9.8/13.0	46.9/54.2	—	—	—	—	—	—	—	—	—	
		MED	NONE	—	—	—	—	—	—	—	—	—	—	—
			323A	3.3/4.4	15.9/18.3	—	—	—	—	—	—	—	—	—
			324A	4.9/6.5	23.5/27.1	—	—	—	—	—	—	—	—	—
			325A	6.5/8.7	31.4/36.3	—	—	—	—	—	—	—	—	—
			326A	7.9/10.5	37.9/43.8	—	—	—	—	—	—	—	—	—
		327A	9.8/13.0	46.9/54.2	—	—	—	—	—	—	—	—	—	
		HIGH	NONE	—	—	—	—	—	—	—	—	—	—	—
			323A	3.3/4.4	15.9/18.3	—	—	—	—	—	—	—	—	—
			324A	4.9/6.5	23.5/27.1	—	—	—	—	—	—	—	—	—
	325A		6.5/8.7	31.4/36.3	—	—	—	—	—	—	—	—	—	
	326A		7.9/10.5	37.9/43.8	—	—	—	—	—	—	—	—	—	
	327A	9.8/13.0	46.9/54.2	—	—	—	—	—	—	—	—	—		
	208/230-3-60	STD	NONE	—	—	25	30	25	87	27	30	27	89	
			323A	3.3/4.4	9.2/10.6	36/38	45/45	35/37	96/98	38/40	45/45	37/39	98/100	
			324A	4.9/6.5	13.6/15.6	42/44	45/50	40/43	101/103	44/46	50/50	43/45	103/105	
			325A	6.5/8.7	18.1/20.9	48/51	50/60	46/49	105/108	49/53	50/60	48/51	107/110	
			326A	7.9/10.5	21.9/25.3	52/57	60/60	50/54	109/112	54/58	60/60	52/56	111/114	
		328A	12.0/16.0	33.4/38.5	67/73	70/80	63/69	120/126	69/75	70/80	65/71	122/128		
		MED	NONE	—	—	27	30	27	89	29	35	29	91	
			323A	3.3/4.4	9.2/10.6	38/40	45/45	37/39	98/100	40/42	45/50	39/41	100/102	
			324A	4.9/6.5	13.6/15.6	44/46	50/50	42/45	103/105	46/48	50/50	45/47	105/107	
			325A	6.5/8.7	18.1/20.9	49/53	50/60	47/51	107/110	51/55	60/60	50/53	109/112	
			326A	7.9/10.5	21.9/25.3	54/58	60/60	52/56	111/114	56/60	60/60	54/58	113/116	
		328A	12.0/16.0	33.4/38.5	68/75	70/80	65/71	122/128	70/77	70/80	67/73	124/130		
		HIGH	NONE	—	—	29	40	29	92	31	40	31	94	
			323A	3.3/4.4	9.2/10.6	40/42	45/50	40/41	101/103	42/44	50/50	42/44	103/105	
			324A	4.9/6.5	13.6/15.6	46/48	50/50	45/47	106/108	48/50	50/50	47/49	108/110	
	325A		6.5/8.7	18.1/20.9	51/55	60/60	50/53	110/113	53/57	60/60	52/55	112/115		
	326A		7.9/10.5	21.9/25.3	56/60	60/60	54/58	114/117	58/62	60/70	57/60	116/119		
	328A	12.0/16.0	33.4/38.5	71/77	80/80	68/73	125/131	72/79	80/80	70/76	127/133			
460-3-60	STD	NONE	—	—	12	15	11	43	13	15	12	44		
		333A	6.0	7.2	21	25	19	50	22	25	21	51		
		334A	8.8	10.6	25	25	23	54	26	30	24	55		
		335A	11.5	13.8	29	30	27	57	30	30	28	58		
		336A	14.0	16.8	33	35	30	60	34	35	32	61		
	MED	NONE	—	—	12	15	12	44	13	15	13	45		
		333A	6.0	7.2	21	25	20	51	22	25	21	52		
		334A	8.8	10.6	25	25	24	55	26	30	25	56		
		335A	11.5	13.8	29	30	27	58	30	30	29	59		
		336A	14.0	16.8	33	35	31	61	34	35	32	62		
	HIGH	NONE	—	—	12	15	12	44	13	15	13	45		
		333A	6.0	7.2	21	25	20	51	22	25	21	52		
		334A	8.8	10.6	25	25	24	55	26	30	25	56		
		335A	11.5	13.8	29	30	28	58	30	30	29	59		
		336A	14.0	16.8	33	35	31	61	34	35	32	62		
575-3-60	STD	NONE	—	—	9	15	8	31	11	15	10	33		
		339A	10.0	9.6	21	25	19	41	23	25	22	43		
		340A	15.0	14.4	27	30	25	45	29	30	27	47		
	MED	NONE	—	—	9	15	9	32	11	15	11	34		
		339A	10.0	9.6	21	25	20	42	23	25	22	44		
		340A	15.0	14.4	27	30	25	46	29	30	27	48		
	HIGH	NONE	—	—	9	15	9	32	11	15	11	34		
		339A	10.0	9.6	21	25	20	42	23	25	22	44		
		340A	15.0	14.4	27	30	26	46	29	30	28	48		
		340A	15.0	14.4	27	30	26	46	29	30	28	48		

50GCQM04 MCA MOCP ELECTRICAL DATA — WITH FACTORY-INSTALLED HACR BREAKER

50GCQ UNIT SIZE	NOM. V-Ph-Hz	IFM TYPE	ELECTRIC HEATER			NO CONVENIENCE OUTLET or UNPOWERED CONVENIENCE OUTLET								
			CRHEATER ****00	NOM (kW)	FLA	NO POWER EXHAUST				w/ POWER EXHAUST (powered from unit)				
						MCA	HACR BRKR	DISCONNECT SIZE		MCA	HACR BRKR	DISCONNECT SIZE		
								FLA	LRA			FLA	LRA	
M04	208/230-1-60	STD	NONE	—	—	24	30	23	93	26	30	25	95	
			323A	3.3/4.4	15.9/18.3	47/47	50/50	41/44	109/111	49/49	50/50	43/46	111/113	
			324A	4.9/6.5	23.5/27.1	58/58	60/60	50/54	117/120	60/60	60/60	52/56	119/122	
			325A	6.5/8.7	31.4/36.3	70/70	70/70	59/65	124/129	72/72	80/80	61/67	126/131	
			326A	7.9/10.5	37.9/43.8	79/79	80/80	67/73	131/137	81/81	90/90	69/76	133/139	
		327A	9.8/13.0	46.9/54.2	92/92	100/100	77/85	140/147	94/94	100/100	79/88	142/149		
		MED	NONE	—	—	26	30	25	95	28	40	27	97	
			323A	3.3/4.4	15.9/18.3	49/49	50/50	43/46	111/113	51/51	60/60	45/48	113/115	
			324A	4.9/6.5	23.5/27.1	60/60	60/60	52/56	119/122	62/62	70/70	54/58	121/124	
			325A	6.5/8.7	31.4/36.3	71/71	80/80	61/67	126/131	73/73	80/80	63/69	128/133	
			326A	7.9/10.5	37.9/43.8	81/81	90/90	69/75	133/139	83/83	90/90	71/78	135/141	
		327A	9.8/13.0	46.9/54.2	94/94	100/100	79/87	142/149	96/96	100/100	81/89	144/151		
	HIGH	NONE	—	—	28	40	27	98	30	40	30	100		
		323A	3.3/4.4	15.9/18.3	51/51	60/60	46/49	114/116	53/53	60/60	48/51	116/118		
		324A	4.9/6.5	23.5/27.1	62/62	70/70	55/59	122/125	64/64	70/70	57/61	124/127		
		325A	6.5/8.7	31.4/36.3	74/74	80/80	64/69	129/134	75/75	80/80	66/71	131/136		
		326A	7.9/10.5	37.9/43.8	83/83	90/90	71/78	136/142	85/85	90/90	73/80	138/144		
	327A	9.8/13.0	46.9/54.2	96/96	100/100	81/90	145/152	98/98	100/100	84/92	147/154			
	M04	208/230-3-60	STD	NONE	—	—	20	30	19	82	22	30	21	84
				323A	3.3/4.4	9.2/10.6	33/33	40/40	30/31	91/93	35/35	40/40	32/34	93/95
				324A	4.9/6.5	13.6/15.6	40/40	45/45	35/37	96/98	42/42	45/45	37/39	98/100
				325A	6.5/8.7	18.1/20.9	46/46	50/50	40/43	100/103	48/48	50/50	42/45	102/105
				326A	7.9/10.5	21.9/25.3	52/52	60/60	44/48	104/107	54/54	60/60	47/50	106/109
			328A	12.0/16.0	33.4/38.5	68/68	70/70	58/63	115/121	70/70	70/70	60/66	117/123	
MED			NONE	—	—	22	30	21	84	24	30	23	86	
			323A	3.3/4.4	9.2/10.6	35/35	40/40	32/33	93/95	37/37	45/45	34/36	95/97	
			324A	4.9/6.5	13.6/15.6	41/41	45/45	37/39	98/100	43/43	50/50	39/41	100/102	
			325A	6.5/8.7	18.1/20.9	48/48	50/50	42/45	102/105	50/50	50/50	44/47	104/107	
			326A	7.9/10.5	21.9/25.3	53/53	60/60	46/50	106/109	55/55	60/60	49/52	108/111	
328A			12.0/16.0	33.4/38.5	70/70	70/70	60/65	117/123	72/72	80/80	62/68	119/125		
HIGH		NONE	—	—	24	30	24	87	26	30	26	89		
		323A	3.3/4.4	9.2/10.6	37/37	45/45	34/36	96/98	39/39	45/45	36/38	98/100		
		324A	4.9/6.5	13.6/15.6	44/44	50/50	39/42	101/103	45/45	50/50	42/44	103/105		
		325A	6.5/8.7	18.1/20.9	50/50	50/50	45/48	105/108	52/52	60/60	47/50	107/110		
		326A	7.9/10.5	21.9/25.3	56/56	60/60	49/53	109/112	58/58	60/60	51/55	111/114		
328A		12.0/16.0	33.4/38.5	72/72	80/80	62/68	120/126	74/74	80/80	64/70	122/128			
M04		460-3-60	STD	NONE	—	—	9	15	9	41	10	15	10	42
				333A	6.0	7.2	18	20	17	48	19	20	18	49
				334A	8.8	10.6	23	25	21	52	24	25	22	53
				335A	11.5	13.8	27	30	24	55	28	30	26	56
				336A	14.0	16.8	30	30	28	58	31	35	29	59
			MED	NONE	—	—	10	15	9	42	11	15	10	43
	333A			6.0	7.2	19	20	17	49	20	20	18	50	
	334A			8.8	10.6	23	25	21	53	24	25	22	54	
	335A			11.5	13.8	27	30	25	56	28	30	26	57	
	336A			14.0	16.8	31	35	28	59	32	35	29	60	
	HIGH		NONE	—	—	10	15	9	42	11	15	10	43	
			333A	6.0	7.2	19	20	18	49	20	20	19	50	
		334A	8.8	10.6	23	25	22	53	24	25	23	54		
		335A	11.5	13.8	27	30	25	56	28	30	26	57		
		336A	14.0	16.8	31	35	29	59	32	35	30	60		
	M04	575-3-60	STD	NONE	—	—	7	15	6	29	9	15	9	31
				339A	10.0	9.6	19	20	17	39	21	25	20	41
				340A	15.0	14.4	25	25	23	43	27	30	25	45
			MED	NONE	—	—	7	15	7	30	9	15	9	32
				339A	10.0	9.6	19	20	18	40	21	25	20	42
				340A	15.0	14.4	25	25	23	44	27	30	25	46
		HIGH	NONE	—	—	8	15	7	30	10	15	9	32	
			339A	10.0	9.6	20	20	18	40	22	25	20	42	
			340A	15.0	14.4	26	30	24	44	28	30	26	46	



50GCQM04 MCA MOCP ELECTRICAL DATA — WITH FACTORY-INSTALLED HACR BREAKER (cont)

50GCQ UNIT SIZE	NOM. V-Ph-Hz	IFM TYPE	ELECTRIC HEATER			w/ POWERED CONVENIENCE OUTLET								
			CRHEATER ****00	NOM (kW)	FLA	NO POWER EXHAUST				w/ POWER EXHAUST (powered from unit)				
						MCA	HACR BRKR	DISCONNECT SIZE		MCA	HACR BRKR	DISCONNECT SIZE		
						FLA	LRA	FLA	LRA	FLA	LRA			
M04	208/230-1-60	STD	NONE	—	—	—	—	—	—	—	—	—	—	—
			323A	3.3/4.4	15.9/18.3	—	—	—	—	—	—	—	—	—
			324A	4.9/6.5	23.5/27.1	—	—	—	—	—	—	—	—	—
			325A	6.5/8.7	31.4/36.3	—	—	—	—	—	—	—	—	—
			326A	7.9/10.5	37.9/43.8	—	—	—	—	—	—	—	—	—
		327A	9.8/13.0	46.9/54.2	—	—	—	—	—	—	—	—	—	
		MED	NONE	—	—	—	—	—	—	—	—	—	—	—
			323A	3.3/4.4	15.9/18.3	—	—	—	—	—	—	—	—	—
			324A	4.9/6.5	23.5/27.1	—	—	—	—	—	—	—	—	—
			325A	6.5/8.7	31.4/36.3	—	—	—	—	—	—	—	—	—
			326A	7.9/10.5	37.9/43.8	—	—	—	—	—	—	—	—	—
		327A	9.8/13.0	46.9/54.2	—	—	—	—	—	—	—	—	—	
		HIGH	NONE	—	—	—	—	—	—	—	—	—	—	—
			323A	3.3/4.4	15.9/18.3	—	—	—	—	—	—	—	—	—
			324A	4.9/6.5	23.5/27.1	—	—	—	—	—	—	—	—	—
			325A	6.5/8.7	31.4/36.3	—	—	—	—	—	—	—	—	—
			326A	7.9/10.5	37.9/43.8	—	—	—	—	—	—	—	—	—
		327A	9.8/13.0	46.9/54.2	—	—	—	—	—	—	—	—	—	
	208/230-3-60	STD	NONE	—	—	25	30	25	87	27	30	27	89	
			323A	3.3/4.4	9.2/10.6	38/38	45/45	35/37	96/98	40/40	45/45	37/39	98/100	
			324A	4.9/6.5	13.6/15.6	44/44	50/50	40/43	101/103	46/46	50/50	43/45	103/105	
			325A	6.5/8.7	18.1/20.9	51/51	60/60	46/49	105/108	53/53	60/60	48/51	107/110	
			326A	7.9/10.5	21.9/25.3	57/57	60/60	50/54	109/112	58/58	60/60	52/56	111/114	
			328A	12.0/16.0	33.4/38.5	73/73	80/80	63/69	120/126	75/75	80/80	65/71	122/128	
		MED	NONE	—	—	27	30	27	89	29	35	29	91	
			323A	3.3/4.4	9.2/10.6	40/40	45/45	37/39	98/100	42/42	50/50	39/41	100/102	
			324A	4.9/6.5	13.6/15.6	46/46	50/50	42/45	103/105	48/48	50/50	45/47	105/107	
			325A	6.5/8.7	18.1/20.9	53/53	60/60	47/51	107/110	55/55	60/60	50/53	109/112	
			326A	7.9/10.5	21.9/25.3	58/58	60/60	52/56	111/114	60/60	60/60	54/58	113/116	
			328A	12.0/16.0	33.4/38.5	75/75	80/80	65/71	122/128	77/77	80/80	67/73	124/130	
		HIGH	NONE	—	—	29	40	29	92	31	40	31	94	
			323A	3.3/4.4	9.2/10.6	42/42	50/50	40/41	101/103	44/44	50/50	42/44	103/105	
			324A	4.9/6.5	13.6/15.6	48/48	50/50	45/47	106/108	50/50	50/50	47/49	108/110	
			325A	6.5/8.7	18.1/20.9	55/55	60/60	50/53	110/113	57/57	60/60	52/55	112/115	
			326A	7.9/10.5	21.9/25.3	60/60	60/60	54/58	114/117	62/62	70/70	57/60	116/119	
			328A	12.0/16.0	33.4/38.5	77/77	80/80	68/73	125/131	79/79	80/80	70/76	127/133	
	460-3-60	STD	NONE	—	—	12	15	11	43	13	15	12	44	
			333A	6.0	7.2	21	25	19	50	22	25	21	51	
			334A	8.8	10.6	25	25	23	54	26	30	24	55	
			335A	11.5	13.8	29	30	27	57	30	30	28	58	
			336A	14.0	16.8	33	35	30	60	34	35	32	61	
		MED	NONE	—	—	12	15	12	44	13	15	13	45	
			333A	6.0	7.2	21	25	20	51	22	25	21	52	
			334A	8.8	10.6	25	25	24	55	26	30	25	56	
			335A	11.5	13.8	29	30	27	58	30	30	29	59	
			336A	14.0	16.8	33	35	31	61	34	35	32	62	
		HIGH	NONE	—	—	12	15	12	44	13	15	13	45	
			333A	6.0	7.2	21	25	20	51	22	25	21	52	
334A			8.8	10.6	25	25	24	55	26	30	25	56		
335A			11.5	13.8	29	30	28	58	30	30	29	59		
336A			14.0	16.8	33	35	31	61	34	35	32	62		
575-3-60		STD	NONE	—	—	9	15	8	31	11	15	10	33	
			339A	10.0	9.6	21	25	19	41	23	25	22	43	
			340A	15.0	14.4	27	30	25	45	29	30	27	47	
	MED	NONE	—	—	9	15	9	32	11	15	11	34		
		339A	10.0	9.6	21	25	20	42	23	25	22	44		
		340A	15.0	14.4	27	30	25	46	29	30	27	48		
	HIGH	NONE	—	—	9	15	9	32	11	15	11	34		
		339A	10.0	9.6	21	25	20	42	23	25	22	44		
		340A	15.0	14.4	27	30	26	46	29	30	28	48		

50GCQM05 MCA MOCP ELECTRICAL DATA

50GCQ UNIT SIZE	NOM. V-Ph-Hz	IFM TYPE	ELECTRIC HEATER			NO CONVENIENCE OUTLET or UNPOWERED CONVENIENCE OUTLET							
			CRHEATER ****00	NOM (kW)	FLA	NO POWER EXHAUST				w/ POWER EXHAUST (powered from unit)			
						MCA	FUSE OR HACR BRKR	DISCONNECT SIZE		MCA	FUSE OR HACR BRKR	DISCONNECT SIZE	
								FLA	LRA			FLA	LRA
M05	208/230-1-60	STD	NONE	—	—	32	50	31	133	34	50	33	135
			323A	3.3/4.4	15.9/18.3	52/55	60/60	49/52	149/151	54/57	60/60	51/54	151/153
			325A	6.5/8.7	31.4/36.3	72/78	80/80	67/73	164/169	74/80	80/80	69/75	166/171
			327A	9.8/13.0	46.9/54.2	91/100	100/100	85/93	180/187	93/102	100/110	87/95	182/189
			329A	13.1/17.4	62.8/72.5	111/123	125/125	103/114	196/206	113/125	125/125	105/116	198/208
			330A	14.4/19.2	69.3/80.0	119/132	125/150	111/123	202/213	121/134	125/150	113/125	204/215
		331A	15.8/21.0	75.8/87.5	127/142	150/150	118/132	209/221	129/144	150/150	120/134	211/223	
		MED	NONE	—	—	35	50	33	136	36	50	36	138
			323A	3.3/4.4	15.9/18.3	54/57	60/60	52/54	152/154	56/59	60/60	54/57	154/156
			325A	6.5/8.7	31.4/36.3	74/80	80/80	69/75	167/172	76/82	80/90	72/77	169/174
			327A	9.8/13.0	46.9/54.2	93/102	100/110	87/96	183/190	95/104	100/110	89/98	185/192
			329A	13.1/17.4	62.8/72.5	113/125	125/125	106/117	199/209	115/127	125/150	108/119	201/211
			330A	14.4/19.2	69.3/80.0	121/135	125/150	113/125	205/216	123/136	125/150	115/128	207/218
		331A	15.8/21.0	75.8/87.5	129/144	150/150	121/134	212/224	131/146	150/150	123/136	214/226	
		HIGH	NONE	—	—	36	50	35	138	38	50	37	140
			323A	3.3/4.4	15.9/18.3	56/59	60/60	54/56	154/156	58/61	60/70	56/59	156/158
			325A	6.5/8.7	31.4/36.3	76/82	80/90	71/77	169/174	77/84	80/90	74/79	171/176
			327A	9.8/13.0	46.9/54.2	95/104	100/110	89/98	185/192	97/106	100/110	91/100	187/194
			329A	13.1/17.4	62.8/72.5	115/127	125/150	108/119	201/211	117/129	125/150	110/121	203/213
			330A	14.4/19.2	69.3/80.0	123/136	125/150	115/127	207/218	125/138	125/150	117/129	209/220
		331A	15.8/21.0	75.8/87.5	131/146	150/150	122/136	214/226	133/148	150/150	125/138	216/228	
	208/230-3-60	STD	NONE	—	—	24	30	24	94	26	30	26	96
			323A	3.3/4.4	9.2/10.6	36/38	45/45	34/36	103/105	38/40	45/50	36/38	105/107
			324A	4.9/6.5	13.6/15.6	41/44	50/50	39/42	108/110	43/46	50/50	41/44	110/112
			325A	6.5/8.7	18.1/20.9	47/51	50/60	44/48	112/115	49/52	50/60	47/50	114/117
			328A	12.0/16.0	33.4/38.5	66/73	70/80	62/68	127/133	68/74	70/80	64/70	129/135
			330A	14.4/19.2	40.0/46.2	74/82	80/90	70/77	134/140	76/84	80/90	72/79	136/142
		331A	15.8/21.0	43.8/50.5	79/88	80/90	74/82	138/145	81/89	90/90	76/84	140/147	
		MED	NONE	—	—	27	30	26	97	28	40	28	99
			323A	3.3/4.4	9.2/10.6	38/40	45/50	37/38	106/108	40/42	50/50	39/40	108/110
			324A	4.9/6.5	13.6/15.6	44/46	50/50	42/44	111/113	45/48	50/50	44/46	113/115
			325A	6.5/8.7	18.1/20.9	49/53	50/60	47/50	115/118	51/55	60/60	49/52	117/120
			328A	12.0/16.0	33.4/38.5	68/75	70/80	64/70	130/136	70/77	70/80	67/72	132/138
			330A	14.4/19.2	40.0/46.2	77/84	80/90	72/79	137/143	78/86	80/90	74/81	139/145
		331A	15.8/21.0	43.8/50.5	81/90	90/90	76/84	141/148	83/92	90/100	79/86	143/150	
		HIGH	NONE	—	—	25	30	24	94	26	30	26	96
			323A	3.3/4.4	9.2/10.6	36/38	45/45	34/36	103/105	38/40	45/50	36/38	105/107
			324A	4.9/6.5	13.6/15.6	42/44	50/50	39/42	108/110	43/46	50/50	42/44	110/112
			325A	6.5/8.7	18.1/20.9	47/51	50/60	45/48	112/115	49/53	50/60	47/50	114/117
			328A	12.0/16.0	33.4/38.5	66/73	70/80	62/68	127/133	68/75	70/80	64/70	129/135
			330A	14.4/19.2	40.0/46.2	75/82	80/90	70/77	134/140	76/84	80/90	72/79	136/142
		331A	15.8/21.0	43.8/50.5	79/88	80/90	74/82	138/145	81/90	90/90	76/84	140/147	
460-3-60	STD	NONE	—	—	13	20	12	45	14	20	13	46	
		333A	6.0	7.2	22	25	20	52	23	25	21	53	
		335A	11.5	13.8	30	30	28	59	31	35	29	60	
		336A	14.0	16.8	34	35	31	62	35	35	32	63	
		337A	21.5	25.9	45	45	42	71	46	50	43	72	
	MED	NONE	—	—	13	20	12	45	14	20	13	46	
		333A	6.0	7.2	22	25	20	52	23	25	22	53	
		335A	11.5	13.8	30	30	28	59	31	35	29	60	
		336A	14.0	16.8	34	35	31	62	35	35	33	63	
		337A	21.5	25.9	45	45	42	71	46	50	43	72	
	HIGH	NONE	—	—	14	20	13	46	15	20	14	47	
		333A	6.0	7.2	23	25	21	53	24	25	23	54	
		335A	11.5	13.8	31	35	29	60	32	35	30	61	
		336A	14.0	16.8	35	35	32	63	36	40	34	64	
		337A	21.5	25.9	46	50	43	72	47	50	44	73	



50GCQM05 MCA MOCPE ELECTRICAL DATA (cont)

50GCQ UNIT SIZE	NOM. V-Ph-Hz	IFM TYPE	ELECTRIC HEATER			NO CONVENIENCE OUTLET or UNPOWERED CONVENIENCE OUTLET							
			CRHEATER ****00	NOM (kW)	FLA	NO POWER EXHAUST				w/ POWER EXHAUST (powered from unit)			
						MCA	FUSE OR HACR BRKR	DISCONNECT SIZE		MCA	FUSE OR HACR BRKR	DISCONNECT SIZE	
FLA	LRA	FLA	LRA										
M05 (cont)	575-3-60	STD	NONE	—	—	8	15	7	37	10	15	9	39
			339A	10.0	9.6	20	20	18	47	22	25	20	49
			340A	15.0	14.4	26	30	24	51	28	30	26	53
		MED	NONE	—	—	8	15	8	37	10	15	10	39
			339A	10.0	9.6	20	20	19	47	22	25	21	49
			340A	15.0	14.4	26	30	24	51	28	30	26	53
		HIGH	NONE	—	—	9	15	8	38	11	15	11	40
			339A	10.0	9.6	21	25	19	48	23	25	22	50
			340A	15.0	14.4	27	30	25	52	29	30	27	54

50GCQM05 MCA MOCP ELECTRICAL DATA (cont)

50GCQ UNIT SIZE	NOM. V-Ph-Hz	IFM TYPE	ELECTRIC HEATER			w/ POWERED CONVENIENCE OUTLET								
			CRHEATER ****00	NOM (kW)	FLA	NO POWER EXHAUST				w/ POWER EXHAUST (powered from unit)				
						MCA	FUSE OR HACR BRKR	DISCONNECT SIZE		MCA	FUSE OR HACR BRKR	DISCONNECT SIZE		
								FLA	LRA			FLA	LRA	
M05	208/230-1-60	STD	NONE	—	—	—	—	—	—	—	—	—	—	—
			323A	3.3/4.4	15.9/18.3	—	—	—	—	—	—	—	—	—
			325A	6.5/8.7	31.4/36.3	—	—	—	—	—	—	—	—	—
			327A	9.8/13.0	46.9/54.2	—	—	—	—	—	—	—	—	—
			329A	13.1/17.4	62.8/72.5	—	—	—	—	—	—	—	—	—
			330A	14.4/19.2	69.3/80.0	—	—	—	—	—	—	—	—	—
		331A	15.8/21.0	75.8/87.5	—	—	—	—	—	—	—	—	—	
		MED	NONE	—	—	—	—	—	—	—	—	—	—	—
			323A	3.3/4.4	15.9/18.3	—	—	—	—	—	—	—	—	—
			325A	6.5/8.7	31.4/36.3	—	—	—	—	—	—	—	—	—
			327A	9.8/13.0	46.9/54.2	—	—	—	—	—	—	—	—	—
			329A	13.1/17.4	62.8/72.5	—	—	—	—	—	—	—	—	—
			330A	14.4/19.2	69.3/80.0	—	—	—	—	—	—	—	—	—
		331A	15.8/21.0	75.8/87.5	—	—	—	—	—	—	—	—	—	
		HIGH	NONE	—	—	—	—	—	—	—	—	—	—	—
			323A	3.3/4.4	15.9/18.3	—	—	—	—	—	—	—	—	—
			325A	6.5/8.7	31.4/36.3	—	—	—	—	—	—	—	—	—
			327A	9.8/13.0	46.9/54.2	—	—	—	—	—	—	—	—	—
			329A	13.1/17.4	62.8/72.5	—	—	—	—	—	—	—	—	—
			330A	14.4/19.2	69.3/80.0	—	—	—	—	—	—	—	—	—
		331A	15.8/21.0	75.8/87.5	—	—	—	—	—	—	—	—	—	
		208/230-3-60	STD	NONE	—	—	29	40	29	99	31	40	31	101
				323A	3.3/4.4	9.2/10.6	41/43	50/50	40/41	108/110	43/44	50/50	42/43	110/112
				324A	4.9/6.5	13.6/15.6	46/49	50/50	45/47	113/115	48/51	50/60	47/49	115/117
	325A			6.5/8.7	18.1/20.9	52/55	60/60	50/53	117/120	54/57	60/60	52/55	119/122	
	328A			12.0/16.0	33.4/38.5	71/77	80/80	68/73	132/138	73/79	80/80	70/76	134/140	
	330A			14.4/19.2	40.0/46.2	79/87	80/90	75/82	139/145	81/89	90/90	77/84	141/147	
	331A		15.8/21.0	43.8/50.5	84/92	90/100	79/87	143/150	86/94	90/100	82/89	145/152		
	MED		NONE	—	—	31	40	32	102	33	45	34	104	
			323A	3.3/4.4	9.2/10.6	43/45	50/50	42/44	111/113	45/47	50/50	44/46	113/115	
			324A	4.9/6.5	13.6/15.6	48/51	50/60	47/49	116/118	50/53	60/60	49/52	118/120	
			325A	6.5/8.7	18.1/20.9	54/57	60/60	52/56	120/123	56/59	60/60	55/58	122/125	
			328A	12.0/16.0	33.4/38.5	73/79	80/80	70/76	135/141	75/81	80/90	72/78	137/143	
			330A	14.4/19.2	40.0/46.2	81/89	90/90	78/85	142/148	83/91	90/100	80/87	144/150	
	331A		15.8/21.0	43.8/50.5	86/94	90/100	82/90	146/153	88/96	90/100	84/92	148/155		
	HIGH		NONE	—	—	29	40	29	99	31	40	31	101	
			323A	3.3/4.4	9.2/10.6	41/43	50/50	40/41	108/110	43/45	50/50	42/44	110/112	
			324A	4.9/6.5	13.6/15.6	46/49	50/50	45/47	113/115	48/51	50/60	47/49	115/117	
			325A	6.5/8.7	18.1/20.9	52/55	60/60	50/53	117/120	54/57	60/60	52/55	119/122	
			328A	12.0/16.0	33.4/38.5	71/77	80/80	68/73	132/138	73/79	80/80	70/76	134/140	
			330A	14.4/19.2	40.0/46.2	79/87	80/90	75/82	139/145	81/89	90/90	77/85	141/147	
	331A		15.8/21.0	43.8/50.5	84/92	90/100	80/87	143/150	86/94	90/100	82/89	145/152		
460-3-60	STD		NONE	—	—	15	20	14	47	16	20	15	48	
			333A	6.0	7.2	24	25	23	54	25	30	24	55	
			335A	11.5	13.8	32	35	30	61	33	35	31	62	
		336A	14.0	16.8	36	40	34	64	37	40	35	65		
		337A	21.5	25.9	47	50	44	73	48	50	45	74		
	MED	NONE	—	—	15	20	15	47	16	20	16	48		
		333A	6.0	7.2	24	30	23	54	25	30	24	55		
		335A	11.5	13.8	32	35	30	61	33	35	32	62		
		336A	14.0	16.8	36	40	34	64	37	40	35	65		
		337A	21.5	25.9	48	50	44	73	49	50	46	74		
	HIGH	NONE	—	—	16	20	16	48	17	20	17	49		
		333A	6.0	7.2	25	30	24	55	26	30	25	56		
		335A	11.5	13.8	33	35	32	62	34	35	33	63		
		336A	14.0	16.8	37	40	35	65	38	40	36	66		
		337A	21.5	25.9	48	50	45	74	49	50	47	75		

50GCQM05 MCA MOCP ELECTRICAL DATA (cont)

50GCQ UNIT SIZE	NOM. V-Ph-Hz	IFM TYPE	ELECTRIC HEATER			w/ POWERED CONVENIENCE OUTLET							
			CRHEATER ****00	NOM (kW)	FLA	NO POWER EXHAUST				w/ POWER EXHAUST (powered from unit)			
						MCA	FUSE OR HACR BRKR	DISCONNECT SIZE		MCA	FUSE OR HACR BRKR	DISCONNECT SIZE	
FLA	LRA	FLA	LRA										
M05 (cont)	575-3-60	STD	NONE	—	—	10	15	9	39	12	15	11	41
			339A	10.0	9.6	22	25	20	49	24	25	22	51
			340A	15.0	14.4	28	30	26	53	30	30	28	55
		MED	NONE	—	—	10	15	10	39	12	15	12	41
			339A	10.0	9.6	22	25	21	49	24	25	23	51
			340A	15.0	14.4	28	30	26	53	30	30	28	55
		HIGH	NONE	—	—	11	15	10	40	13	15	13	42
			339A	10.0	9.6	23	25	21	50	25	25	24	52
			340A	15.0	14.4	29	30	27	54	31	35	29	56

50GCQM05 MCA MOCP ELECTRICAL DATA — WITH FACTORY-INSTALLED HACR BREAKER

50GCQ UNIT SIZE	NOM. V-Ph-Hz	IFM TYPE	ELECTRIC HEATER			NO CONVENIENCE OUTLET or UNPOWERED CONVENIENCE OUTLET							
			CRHEATER ****00	NOM (kW)	FLA	NO POWER EXHAUST				w/ POWER EXHAUST (powered from unit)			
						MCA	HACR BRKR	DISCONNECT SIZE		MCA	HACR BRKR	DISCONNECT SIZE	
								FLA	LRA			FLA	LRA
M05	208/230-1-60	STD	NONE	—	—	32	50	31	133	34	50	33	135
			323A	3.3/4.4	15.9/18.3	55/55	60/60	49/52	149/151	57/57	60/60	51/54	151/153
			325A	6.5/8.7	31.4/36.3	78/78	80/80	67/73	164/169	80/80	80/80	69/75	166/171
			327A	9.8/13.0	46.9/54.2	100/100	100/100	85/93	180/187	102/102	110/110	87/95	182/189
			329A	13.1/17.4	62.8/72.5	123/123	125/125	103/114	196/206	125/125	125/125	105/116	198/208
			330A	14.4/19.2	69.3/80.0	132/132	150/150	111/123	202/213	134/134	150/150	113/125	204/215
		331A	15.8/21.0	75.8/87.5	142/142	150/150	118/132	209/221	144/144	150/150	120/134	211/223	
		MED	NONE	—	—	35	50	33	136	36	50	36	138
			323A	3.3/4.4	15.9/18.3	57/57	60/60	52/54	152/154	59/59	60/60	54/57	154/156
			325A	6.5/8.7	31.4/36.3	80/80	80/80	69/75	167/172	82/82	90/90	72/77	169/174
			327A	9.8/13.0	46.9/54.2	102/102	110/110	87/96	183/190	104/104	110/110	89/98	185/192
			329A	13.1/17.4	62.8/72.5	125/125	125/125	106/117	199/209	127/127	150/150	108/119	201/211
			330A	14.4/19.2	69.3/80.0	135/135	150/150	113/125	205/216	136/136	150/150	115/128	207/218
		331A	15.8/21.0	75.8/87.5	144/144	150/150	121/134	212/224	146/146	150/150	123/136	214/226	
		HIGH	NONE	—	—	36	50	35	138	38	50	37	140
			323A	3.3/4.4	15.9/18.3	59/59	60/60	54/56	154/156	61/61	70/70	56/59	156/158
			325A	6.5/8.7	31.4/36.3	82/82	90/90	71/77	169/174	84/84	90/90	74/79	171/176
			327A	9.8/13.0	46.9/54.2	104/104	110/110	89/98	185/192	106/106	110/110	91/100	187/194
	329A		13.1/17.4	62.8/72.5	127/127	150/150	108/119	201/211	129/129	150/150	110/121	203/213	
	330A		14.4/19.2	69.3/80.0	136/136	150/150	115/127	207/218	138/138	150/150	117/129	209/220	
	331A	15.8/21.0	75.8/87.5	146/146	150/150	122/136	214/226	148/148	150/150	125/138	216/228		
	208/230-3-60	STD	NONE	—	—	24	30	24	94	26	30	26	96
			323A	3.3/4.4	9.2/10.6	38/38	45/45	34/36	103/105	40/40	50/50	36/38	105/107
			324A	4.9/6.5	13.6/15.6	44/44	50/50	39/42	108/110	46/46	50/50	41/44	110/112
			325A	6.5/8.7	18.1/20.9	51/51	60/60	44/48	112/115	52/52	60/60	47/50	114/117
			328A	12.0/16.0	33.4/38.5	73/73	80/80	62/68	127/133	74/74	80/80	64/70	129/135
			330A	14.4/19.2	40.0/46.2	82/82	90/90	70/77	134/140	84/84	90/90	72/79	136/142
		331A	15.8/21.0	43.8/50.5	88/88	90/90	74/82	138/145	89/89	90/90	76/84	140/147	
		MED	NONE	—	—	27	30	26	97	28	40	28	99
			323A	3.3/4.4	9.2/10.6	40/40	50/50	37/38	106/108	42/42	50/50	39/40	108/110
			324A	4.9/6.5	13.6/15.6	46/46	50/50	42/44	111/113	48/48	50/50	44/46	113/115
			325A	6.5/8.7	18.1/20.9	53/53	60/60	47/50	115/118	55/55	60/60	49/52	117/120
			328A	12.0/16.0	33.4/38.5	75/75	80/80	64/70	130/136	77/77	80/80	67/72	132/138
			330A	14.4/19.2	40.0/46.2	84/84	90/90	72/79	137/143	86/86	90/90	74/81	139/145
		331A	15.8/21.0	43.8/50.5	90/90	90/90	76/84	141/148	92/92	100/100	79/86	143/150	
		HIGH	NONE	—	—	25	30	24	94	26	30	26	96
323A			3.3/4.4	9.2/10.6	38/38	45/45	34/36	103/105	40/40	50/50	36/38	105/107	
324A			4.9/6.5	13.6/15.6	44/44	50/50	39/42	108/110	46/46	50/50	42/44	110/112	
325A			6.5/8.7	18.1/20.9	51/51	60/60	45/48	112/115	53/53	60/60	47/50	114/117	
328A	12.0/16.0		33.4/38.5	73/73	80/80	62/68	127/133	75/75	80/80	64/70	129/135		
330A	14.4/19.2		40.0/46.2	82/82	90/90	70/77	134/140	84/84	90/90	72/79	136/142		
331A	15.8/21.0	43.8/50.5	88/88	90/90	74/82	138/145	90/90	90/90	76/84	140/147			
460-3-60	STD	NONE	—	—	13	20	12	45	14	20	13	46	
		333A	6.0	7.2	22	25	20	52	23	25	21	53	
		335A	11.5	13.8	30	30	28	59	31	35	29	60	
		336A	14.0	16.8	34	35	31	62	35	35	32	63	
		337A	21.5	25.9	45	45	42	71	46	50	43	72	
	MED	NONE	—	—	13	20	12	45	14	20	13	46	
		333A	6.0	7.2	22	25	20	52	23	25	22	53	
		335A	11.5	13.8	30	30	28	59	31	35	29	60	
		336A	14.0	16.8	34	35	31	62	35	35	33	63	
		337A	21.5	25.9	45	45	42	71	46	50	43	72	
	HIGH	NONE	—	—	14	20	13	46	15	20	14	47	
		333A	6.0	7.2	23	25	21	53	24	25	23	54	
		335A	11.5	13.8	31	35	29	60	32	35	30	61	
		336A	14.0	16.8	35	35	32	63	36	40	34	64	
		337A	21.5	25.9	46	50	43	72	47	50	44	73	



50GCQM05 MCA MOCP ELECTRICAL DATA — WITH FACTORY-INSTALLED HACR BREAKER (cont)

50GCQ UNIT SIZE	NOM. V-Ph-Hz	IFM TYPE	ELECTRIC HEATER			NO CONVENIENCE OUTLET or UNPOWERED CONVENIENCE OUTLET							
			CRHEATER ****00	NOM (kW)	FLA	NO POWER EXHAUST				w/ POWER EXHAUST (powered from unit)			
						MCA	HACR BRKR	DISCONNECT SIZE		MCA	HACR BRKR	DISCONNECT SIZE	
								FLA	LRA			FLA	LRA
M05 (cont)	575-3-60	STD	NONE	—	—	8	15	7	37	10	15	9	39
			339A	10.0	9.6	20	20	18	47	22	25	20	49
			340A	15.0	14.4	26	30	24	51	28	30	26	53
		MED	NONE	—	—	8	15	8	37	10	15	10	39
			339A	10.0	9.6	20	20	19	47	22	25	21	49
			340A	15.0	14.4	26	30	24	51	28	30	26	53
		HIGH	NONE	—	—	9	15	8	38	11	15	11	40
			339A	10.0	9.6	21	25	19	48	23	25	22	50
			340A	15.0	14.4	27	30	25	52	29	30	27	54

50GCQM05 MCA MOCAP ELECTRICAL DATA — WITH FACTORY-INSTALLED HACR BREAKER (cont)

50GCQ UNIT SIZE	NOM. V-Ph-Hz	IFM TYPE	ELECTRIC HEATER			w/ POWERED CONVENIENCE OUTLET								
			CRHEATER ****00	NOM (kW)	FLA	NO POWER EXHAUST				w/ POWER EXHAUST (powered from unit)				
						MCA	HACR BRKR	DISCONNECT SIZE		MCA	HACR BRKR	DISCONNECT SIZE		
FLA	LRA	FLA	LRA											
M05	208/230-1-60	STD	NONE	—	—	—	—	—	—	—	—	—	—	—
			323A	3.3/4.4	15.9/18.3	—	—	—	—	—	—	—	—	—
			325A	6.5/8.7	31.4/36.3	—	—	—	—	—	—	—	—	—
			327A	9.8/13.0	46.9/54.2	—	—	—	—	—	—	—	—	—
			329A	13.1/17.4	62.8/72.5	—	—	—	—	—	—	—	—	—
			330A	14.4/19.2	69.3/80.0	—	—	—	—	—	—	—	—	—
		331A	15.8/21.0	75.8/87.5	—	—	—	—	—	—	—	—	—	
		MED	NONE	—	—	—	—	—	—	—	—	—	—	—
			323A	3.3/4.4	15.9/18.3	—	—	—	—	—	—	—	—	—
			325A	6.5/8.7	31.4/36.3	—	—	—	—	—	—	—	—	—
			327A	9.8/13.0	46.9/54.2	—	—	—	—	—	—	—	—	—
			329A	13.1/17.4	62.8/72.5	—	—	—	—	—	—	—	—	—
	330A		14.4/19.2	69.3/80.0	—	—	—	—	—	—	—	—	—	
	331A	15.8/21.0	75.8/87.5	—	—	—	—	—	—	—	—	—		
	HIGH	NONE	—	—	—	—	—	—	—	—	—	—	—	
		323A	3.3/4.4	15.9/18.3	—	—	—	—	—	—	—	—	—	
		325A	6.5/8.7	31.4/36.3	—	—	—	—	—	—	—	—	—	
		327A	9.8/13.0	46.9/54.2	—	—	—	—	—	—	—	—	—	
		329A	13.1/17.4	62.8/72.5	—	—	—	—	—	—	—	—	—	
		330A	14.4/19.2	69.3/80.0	—	—	—	—	—	—	—	—	—	
	331A	15.8/21.0	75.8/87.5	—	—	—	—	—	—	—	—	—		
	208/230-3-60	STD	NONE	—	—	29	40	29	99	31	40	31	101	
			323A	3.3/4.4	9.2/10.6	43/43	50/50	40/41	108/110	44/44	50/50	42/43	110/112	
			324A	4.9/6.5	13.6/15.6	49/49	50/50	45/47	113/115	51/51	60/60	47/49	115/117	
325A			6.5/8.7	18.1/20.9	55/55	60/60	50/53	117/120	57/57	60/60	52/55	119/122		
328A			12.0/16.0	33.4/38.5	77/77	80/80	68/73	132/138	79/79	80/80	70/76	134/140		
330A			14.4/19.2	40.0/46.2	87/87	90/90	75/82	139/145	89/89	90/90	77/84	141/147		
331A		15.8/21.0	43.8/50.5	92/92	100/100	79/87	143/150	94/94	100/100	82/89	145/152			
MED		NONE	—	—	31	40	32	102	33	45	34	104		
		323A	3.3/4.4	9.2/10.6	45/45	50/50	42/44	111/113	47/47	50/50	44/46	113/115		
		324A	4.9/6.5	13.6/15.6	51/51	60/60	47/49	116/118	53/53	60/60	49/52	118/120		
		325A	6.5/8.7	18.1/20.9	57/57	60/60	52/56	120/123	59/59	60/60	55/58	122/125		
		328A	12.0/16.0	33.4/38.5	79/79	80/80	70/76	135/141	81/81	90/90	72/78	137/143		
	330A	14.4/19.2	40.0/46.2	89/89	90/90	78/85	142/148	91/91	100/100	80/87	144/150			
331A	15.8/21.0	43.8/50.5	94/94	100/100	82/90	146/153	96/96	100/100	84/92	148/155				
HIGH	NONE	—	—	29	40	29	99	31	40	31	101			
	323A	3.3/4.4	9.2/10.6	43/43	50/50	40/41	108/110	45/45	50/50	42/44	110/112			
	324A	4.9/6.5	13.6/15.6	49/49	50/50	45/47	113/115	51/51	60/60	47/49	115/117			
	325A	6.5/8.7	18.1/20.9	55/55	60/60	50/53	117/120	57/57	60/60	52/55	119/122			
	328A	12.0/16.0	33.4/38.5	77/77	80/80	68/73	132/138	79/79	80/80	70/76	134/140			
	330A	14.4/19.2	40.0/46.2	87/87	90/90	75/82	139/145	89/89	90/90	77/85	141/147			
331A	15.8/21.0	43.8/50.5	92/92	100/100	80/87	143/150	94/94	100/100	82/89	145/152				
460-3-60	STD	NONE	—	—	15	20	14	47	16	20	15	48		
		333A	6.0	7.2	24	25	23	54	25	30	24	55		
		335A	11.5	13.8	32	35	30	61	33	35	31	62		
		336A	14.0	16.8	36	40	34	64	37	40	35	65		
		337A	21.5	25.9	47	50	44	73	48	50	45	74		
	MED	NONE	—	—	15	20	15	47	16	20	16	48		
		333A	6.0	7.2	24	30	23	54	25	30	24	55		
		335A	11.5	13.8	32	35	30	61	33	35	32	62		
		336A	14.0	16.8	36	40	34	64	37	40	35	65		
	337A	21.5	25.9	48	50	44	73	49	50	46	74			
	HIGH	NONE	—	—	16	20	16	48	17	20	17	49		
		333A	6.0	7.2	25	30	24	55	26	30	25	56		
335A		11.5	13.8	33	35	32	62	34	35	33	63			
336A		14.0	16.8	37	40	35	65	38	40	36	66			
337A		21.5	25.9	48	50	45	74	49	50	47	75			



50GCQM05 MCA MOCP ELECTRICAL DATA — WITH FACTORY-INSTALLED HACR BREAKER (cont)

50GCQ UNIT SIZE	NOM. V-Ph-Hz	IFM TYPE	ELECTRIC HEATER			w/ POWERED CONVENIENCE OUTLET							
			CRHEATER ****00	NOM (kW)	FLA	NO POWER EXHAUST				w/ POWER EXHAUST (powered from unit)			
						MCA	HACR BRKR	DISCONNECT SIZE		MCA	HACR BRKR	DISCONNECT SIZE	
FLA	LRA	FLA	LRA										
M05 (cont)	575-3-60	STD	NONE	—	—	10	15	9	39	12	15	11	41
			339A	10.0	9.6	22	25	20	49	24	25	22	51
			340A	15.0	14.4	28	30	26	53	30	30	28	55
		MED	NONE	—	—	10	15	10	39	12	15	12	41
			339A	10.0	9.6	22	25	21	49	24	25	23	51
			340A	15.0	14.4	28	30	26	53	30	30	28	55
		HIGH	NONE	—	—	11	15	10	40	13	15	13	42
			339A	10.0	9.6	23	25	21	50	25	25	24	52
			340A	15.0	14.4	29	30	27	54	31	35	29	56

50GCQM06 MCA MOCP ELECTRICAL DATA

50GCQ UNIT SIZE	NOM. V-Ph-Hz	IFM TYPE	ELECTRIC HEATER			NO CONVENIENCE OUTLET or UNPOWERED CONVENIENCE OUTLET							
			CRHEATER ****00	NOM (kW)	FLA	NO POWER EXHAUST				w/ POWER EXHAUST (powered from unit)			
						MCA	FUSE OR HACR BRKR	DISCONNECT SIZE		MCA	FUSE OR HACR BRKR	DISCONNECT SIZE	
							FLA	LRA			FLA	LRA	
M06	208/230-1-60	STD	NONE	—	—	40	60	38	161	42	60	40	163
			324A	4.9/6.5	23.5/27.1	69/74	80/80	65/69	185/188	71/76	80/80	68/72	187/190
			325A	6.5/8.7	31.4/36.3	79/85	80/100	74/80	192/197	81/87	90/100	77/82	194/199
			327A	9.8/13.0	46.9/54.2	99/108	100/110	92/101	208/215	100/110	100/110	94/103	210/217
			329A	13.1/17.4	62.8/72.5	118/131	125/150	111/122	224/234	120/132	125/150	113/124	226/236
			331A	15.8/21.0	75.8/87.5	135/149	150/150	125/139	237/249	137/151	150/175	128/141	239/251
		MED	NONE	—	—	41	60	40	163	43	60	42	165
			324A	4.9/6.5	23.5/27.1	71/75	80/80	67/71	187/190	73/77	80/80	69/73	189/192
			325A	6.5/8.7	31.4/36.3	81/87	90/100	76/82	194/199	82/89	90/100	78/84	196/201
			327A	9.8/13.0	46.9/54.2	100/109	100/110	94/102	210/217	102/111	110/125	96/104	212/219
			329A	13.1/17.4	62.8/72.5	120/132	125/150	112/123	226/236	122/134	125/150	114/125	228/238
			331A	15.8/21.0	75.8/87.5	136/151	150/175	127/141	239/251	138/153	150/175	129/143	241/253
		HIGH	NONE	—	—	41	60	39	162	43	60	42	164
			324A	4.9/6.5	23.5/27.1	70/75	80/80	66/70	186/189	72/77	80/80	69/73	188/191
			325A	6.5/8.7	31.4/36.3	80/86	80/100	75/81	193/198	82/88	90/100	78/83	195/200
			327A	9.8/13.0	46.9/54.2	99/109	100/110	93/102	209/216	101/110	110/110	95/104	211/218
			329A	13.1/17.4	62.8/72.5	119/131	125/150	112/123	225/235	121/133	125/150	114/125	227/237
			331A	15.8/21.0	75.8/87.5	136/150	150/150	127/140	238/250	137/152	150/175	129/142	240/252
	208/230-3-60	STD	NONE	—	—	30	45	29	124	32	45	31	126
			324A	4.9/6.5	13.6/15.6	47/49	50/60	45/47	138/140	49/51	60/60	47/49	140/142
			326A	7.9/10.5	21.9/25.3	57/61	60/70	54/58	146/149	59/63	60/70	56/60	148/151
			328A	12.0/16.0	33.4/38.5	72/78	80/80	67/73	157/163	73/80	80/80	70/75	159/165
			331A	15.8/21.0	43.8/50.5	85/93	90/100	79/87	168/175	86/95	90/100	82/89	170/177
			332A	18.4/24.5	51.1/58.9	94/103	100/110	88/97	175/183	96/105	100/110	90/99	177/185
		MED	NONE	—	—	31	45	31	126	33	45	33	128
			324A	4.9/6.5	13.6/15.6	48/51	60/60	46/49	140/142	50/53	60/60	48/51	142/144
			326A	7.9/10.5	21.9/25.3	59/63	60/70	56/60	148/151	60/65	60/70	58/62	150/153
			328A	12.0/16.0	33.4/38.5	73/79	80/80	69/75	159/165	75/81	80/90	71/77	161/167
			331A	15.8/21.0	43.8/50.5	86/94	90/100	81/89	170/177	88/96	90/100	83/91	172/179
			332A	18.4/24.5	51.1/58.9	95/105	100/110	89/98	177/185	97/107	100/110	92/101	179/187
		HIGH	NONE	—	—	29	45	28	123	31	45	30	125
			324A	4.9/6.5	13.6/15.6	46/48	50/60	44/46	137/139	48/50	60/60	46/48	139/141
			326A	7.9/10.5	21.9/25.3	56/61	60/70	53/57	145/148	58/63	60/70	55/59	147/150
			328A	12.0/16.0	33.4/38.5	71/77	80/80	66/72	156/162	73/79	80/80	69/75	158/164
			331A	15.8/21.0	43.8/50.5	84/92	90/100	78/86	167/174	86/94	90/100	81/88	169/176
			332A	18.4/24.5	51.1/58.9	93/103	100/110	87/96	174/182	95/105	100/110	89/98	176/184
460-3-60	STD	NONE	—	—	17	25	15	56	18	25	16	57	
		333A	6.0	7.2	26	30	24	63	27	30	25	64	
		335A	11.5	13.8	34	40	31	70	35	40	32	71	
		336A	14.0	16.8	38	40	35	73	39	40	36	74	
		337A	21.5	25.9	49	50	45	82	50	50	46	83	
		338A	24.0	28.9	53	60	49	85	54	60	50	86	
	MED	NONE	—	—	17	25	16	57	18	25	17	58	
		333A	6.0	7.2	26	30	24	64	27	30	25	65	
		335A	11.5	13.8	34	40	32	71	35	40	33	72	
		336A	14.0	16.8	38	40	35	74	39	45	36	75	
		337A	21.5	25.9	49	50	46	83	50	50	47	84	
		338A	24.0	28.9	53	60	49	86	54	60	50	87	
	HIGH	NONE	—	—	18	25	17	58	19	25	18	59	
		333A	6.0	7.2	27	30	25	65	28	30	26	66	
		335A	11.5	13.8	35	40	33	72	36	40	34	73	
		336A	14.0	16.8	39	45	36	75	40	45	37	76	
		337A	21.5	25.9	50	50	47	84	51	60	48	85	
		338A	24.0	28.9	54	60	50	87	55	60	51	88	



50GCQM06 MCA MOCPE ELECTRICAL DATA (cont)

50GCQ UNIT SIZE	NOM. V-Ph-Hz	IFM TYPE	ELECTRIC HEATER			NO CONVENIENCE OUTLET or UNPOWERED CONVENIENCE OUTLET							
			CRHEATER ****00	NOM (kW)	FLA	NO POWER EXHAUST				w/ POWER EXHAUST (powered from unit)			
						MCA	FUSE OR HACR BRKR	DISCONNECT SIZE		MCA	FUSE OR HACR BRKR	DISCONNECT SIZE	
FLA	LRA	FLA	LRA										
M06 (cont)	575-3-60	STD	NONE	—	—	13	20	12	43	15	20	14	45
			340A	15.0	14.4	31	35	29	57	33	35	31	59
			341A	21.0	20.2	38	40	35	63	40	40	37	65
		MED	NONE	—	—	13	20	12	44	15	20	14	46
			340A	15.0	14.4	31	35	29	58	33	35	31	60
			341A	21.0	20.2	38	40	36	64	40	40	38	66
		HIGH	NONE	—	—	14	20	13	45	16	20	15	47
			340A	15.0	14.4	32	35	30	59	34	35	32	61
			341A	21.0	20.2	39	40	36	65	41	45	39	67

50GCQM06 MCA MOCP ELECTRICAL DATA (cont)

50GCQ UNIT SIZE	NOM. V-Ph-Hz	IFM TYPE	ELECTRIC HEATER			w/ POWERED CONVENIENCE OUTLET										
			CRHEATER ****00	NOM (kW)	FLA	NO POWER EXHAUST				w/ POWER EXHAUST (powered from unit)						
						MCA	FUSE OR HACR BRKR	DISCONNECT SIZE		MCA	FUSE OR HACR BRKR	DISCONNECT SIZE				
					FLA	LRA	MCA	FUSE OR HACR BRKR	FLA	LRA	MCA	FUSE OR HACR BRKR	FLA	LRA		
M06	208/230-1-60	STD	NONE	—	—	—	—	—	—	—	—	—	—	—	—	
			324A	4.9/6.5	23.5/27.1	—	—	—	—	—	—	—	—	—	—	—
			325A	6.5/8.7	31.4/36.3	—	—	—	—	—	—	—	—	—	—	—
			327A	9.8/13.0	46.9/54.2	—	—	—	—	—	—	—	—	—	—	—
			329A	13.1/17.4	62.8/72.5	—	—	—	—	—	—	—	—	—	—	—
			331A	15.8/21.0	75.8/87.5	—	—	—	—	—	—	—	—	—	—	—
		MED	NONE	—	—	—	—	—	—	—	—	—	—	—	—	—
			324A	4.9/6.5	23.5/27.1	—	—	—	—	—	—	—	—	—	—	—
			325A	6.5/8.7	31.4/36.3	—	—	—	—	—	—	—	—	—	—	—
			327A	9.8/13.0	46.9/54.2	—	—	—	—	—	—	—	—	—	—	—
			329A	13.1/17.4	62.8/72.5	—	—	—	—	—	—	—	—	—	—	—
			331A	15.8/21.0	75.8/87.5	—	—	—	—	—	—	—	—	—	—	—
		HIGH	NONE	—	—	—	—	—	—	—	—	—	—	—	—	—
			324A	4.9/6.5	23.5/27.1	—	—	—	—	—	—	—	—	—	—	—
			325A	6.5/8.7	31.4/36.3	—	—	—	—	—	—	—	—	—	—	—
			327A	9.8/13.0	46.9/54.2	—	—	—	—	—	—	—	—	—	—	—
			329A	13.1/17.4	62.8/72.5	—	—	—	—	—	—	—	—	—	—	—
			331A	15.8/21.0	75.8/87.5	—	—	—	—	—	—	—	—	—	—	—
	208/230-3-60	STD	NONE	—	—	35	50	35	129	36	50	37	131			
			324A	4.9/6.5	13.6/15.6	52/54	60/60	50/52	143/145	53/56	60/60	52/55	145/147			
			326A	7.9/10.5	21.9/25.3	62/66	70/70	60/64	151/154	64/68	70/70	62/66	153/156			
			328A	12.0/16.0	33.4/38.5	76/83	80/90	73/79	162/168	78/85	80/90	75/81	164/170			
			331A	15.8/21.0	43.8/50.5	89/98	90/100	85/93	173/180	91/100	100/100	87/95	175/182			
			332A	18.4/24.5	51.1/58.9	98/108	100/110	93/102	180/188	100/110	100/110	95/104	182/190			
		MED	NONE	—	—	36	50	36	131	38	50	38	133			
			324A	4.9/6.5	13.6/15.6	53/55	60/60	52/54	145/147	55/57	60/60	54/56	147/149			
			326A	7.9/10.5	21.9/25.3	63/68	70/70	61/65	153/156	65/70	70/70	63/67	155/158			
			328A	12.0/16.0	33.4/38.5	78/84	80/90	75/80	164/170	80/86	80/90	77/83	166/172			
			331A	15.8/21.0	43.8/50.5	91/99	100/100	86/94	175/182	93/101	100/110	89/96	177/184			
			332A	18.4/24.5	51.1/58.9	100/110	100/110	95/104	182/190	102/112	110/125	97/106	184/192			
		HIGH	NONE	—	—	34	45	34	128	36	50	36	130			
			324A	4.9/6.5	13.6/15.6	51/53	60/60	49/52	142/144	53/55	60/60	51/54	144/146			
			326A	7.9/10.5	21.9/25.3	61/65	70/70	59/63	150/153	63/67	70/70	61/65	152/155			
			328A	12.0/16.0	33.4/38.5	76/82	80/90	72/78	161/167	77/84	80/90	74/80	163/169			
			331A	15.8/21.0	43.8/50.5	89/97	90/100	84/92	172/179	90/99	90/100	86/94	174/181			
			332A	18.4/24.5	51.1/58.9	98/107	100/110	92/101	179/187	100/109	100/110	95/104	181/189			
460-3-60	STD	NONE	—	—	19	25	18	58	20	30	19	59				
		333A	6.0	7.2	28	30	26	65	29	30	27	66				
		335A	11.5	13.8	36	40	34	72	37	40	35	73				
		336A	14.0	16.8	40	45	37	75	41	45	38	76				
		337A	21.5	25.9	51	60	48	84	52	60	49	85				
		338A	24.0	28.9	55	60	51	87	56	60	52	88				
	MED	NONE	—	—	19	25	18	59	20	30	19	60				
		333A	6.0	7.2	28	30	27	66	29	30	28	67				
		335A	11.5	13.8	36	40	34	73	37	40	35	74				
		336A	14.0	16.8	40	45	38	76	41	45	39	77				
		337A	21.5	25.9	51	60	48	85	52	60	49	86				
		338A	24.0	28.9	55	60	52	88	56	60	53	89				
	HIGH	NONE	—	—	20	30	19	60	21	30	21	61				
		333A	6.0	7.2	29	30	28	67	30	35	29	68				
		335A	11.5	13.8	37	40	35	74	38	45	36	75				
		336A	14.0	16.8	41	45	39	77	42	45	40	78				
		337A	21.5	25.9	52	60	49	86	53	60	50	87				
		338A	24.0	28.9	56	60	53	89	57	60	54	90				



50GCQM06 MCA MOCP ELECTRICAL DATA (cont)

50GCQ UNIT SIZE	NOM. V-Ph-Hz	IFM TYPE	ELECTRIC HEATER			w/ POWERED CONVENIENCE OUTLET							
			CRHEATER ****00	NOM (kW)	FLA	NO POWER EXHAUST				w/ POWER EXHAUST (powered from unit)			
						MCA	FUSE OR HACR BRKR	DISCONNECT SIZE		MCA	FUSE OR HACR BRKR	DISCONNECT SIZE	
FLA	LRA	FLA	LRA										
M06 (cont)	575-3-60	STD	NONE	—	—	15	20	14	45	17	20	16	47
			340A	15.0	14.4	33	35	30	59	35	35	33	61
			341A	21.0	20.2	40	40	37	65	42	45	39	67
		MED	NONE	—	—	15	20	14	46	17	20	16	48
			340A	15.0	14.4	33	35	31	60	35	35	33	62
			341A	21.0	20.2	40	40	37	66	42	45	40	68
		HIGH	NONE	—	—	16	20	15	47	18	25	17	49
			340A	15.0	14.4	34	35	32	61	36	40	34	63
			341A	21.0	20.2	41	45	38	67	43	45	40	69

50GCQM06 MCA MOCP ELECTRICAL DATA — WITH FACTORY-INSTALLED HACR BREAKER

50GCQ UNIT SIZE	NOM. V-Ph-Hz	IFM TYPE	ELECTRIC HEATER			NO CONVENIENCE OUTLET or UNPOWERED CONVENIENCE OUTLET							
			CRHEATER ****00	NOM (kW)	FLA	NO POWER EXHAUST				w/ POWER EXHAUST (powered from unit)			
						MCA	HACR BRKR	DISCONNECT SIZE		MCA	HACR BRKR	DISCONNECT SIZE	
							FLA	LRA			FLA	LRA	
M06	208/230-1-60	STD	NONE	—	—	40	60	38	161	42	60	40	163
			324A	4.9/6.5	23.5/27.1	74/74	80/80	65/69	185/188	76/76	80/80	68/72	187/190
			325A	6.5/8.7	31.4/36.3	85/85	100/100	74/80	192/197	87/87	100/100	77/82	194/199
			327A	9.8/13.0	46.9/54.2	108/108	110/110	92/101	208/215	110/110	110/110	94/103	210/217
			329A	13.1/17.4	62.8/72.5	131/131	150/150	111/122	224/234	132/132	150/150	113/124	226/236
			331A	15.8/21.0	75.8/87.5	149/149	150/150	125/139	237/249	151/151	175/175	128/141	239/251
		MED	NONE	—	—	41	60	40	163	43	60	42	165
			324A	4.9/6.5	23.5/27.1	75/75	80/80	67/71	187/190	77/77	80/80	69/73	189/192
			325A	6.5/8.7	31.4/36.3	87/87	100/100	76/82	194/199	89/89	100/100	78/84	196/201
			327A	9.8/13.0	46.9/54.2	109/109	110/110	94/102	210/217	111/111	125/125	96/104	212/219
			329A	13.1/17.4	62.8/72.5	132/132	150/150	112/123	226/236	134/134	150/150	114/125	228/238
			331A	15.8/21.0	75.8/87.5	151/151	175/175	127/141	239/251	153/153	175/175	129/143	241/253
		HIGH	NONE	—	—	41	60	39	162	43	60	42	164
			324A	4.9/6.5	23.5/27.1	75/75	80/80	66/70	186/189	77/77	80/80	69/73	188/191
			325A	6.5/8.7	31.4/36.3	86/86	100/100	75/81	193/198	88/88	100/100	78/83	195/200
			327A	9.8/13.0	46.9/54.2	109/109	110/110	93/102	209/216	110/110	110/110	95/104	211/218
			329A	13.1/17.4	62.8/72.5	131/131	150/150	112/123	225/235	133/133	150/150	114/125	227/237
			331A	15.8/21.0	75.8/87.5	150/150	150/150	127/140	238/250	152/152	175/175	129/142	240/252
	208/230-3-60	STD	NONE	—	—	30	45	29	124	32	45	31	126
			324A	4.9/6.5	13.6/15.6	49/49	60/60	45/47	138/140	51/51	60/60	47/49	140/142
			326A	7.9/10.5	21.9/25.3	61/61	70/70	54/58	146/149	63/63	70/70	56/60	148/151
			328A	12.0/16.0	33.4/38.5	78/78	80/80	67/73	157/163	80/80	80/80	70/75	159/165
			331A	15.8/21.0	43.8/50.5	93/93	100/100	79/87	168/175	95/95	100/100	82/89	170/177
			332A	18.4/24.5	51.1/58.9	103/103	110/110	88/97	175/183	105/105	110/110	90/99	177/185
		MED	NONE	—	—	31	45	31	126	33	45	33	128
			324A	4.9/6.5	13.6/15.6	51/51	60/60	46/49	140/142	53/53	60/60	48/51	142/144
			326A	7.9/10.5	21.9/25.3	63/63	70/70	56/60	148/151	65/65	70/70	58/62	150/153
			328A	12.0/16.0	33.4/38.5	79/79	80/80	69/75	159/165	81/81	90/90	71/77	161/167
			331A	15.8/21.0	43.8/50.5	94/94	100/100	81/89	170/177	96/96	100/100	83/91	172/179
			332A	18.4/24.5	51.1/58.9	105/105	110/110	89/98	177/185	107/107	110/110	92/101	179/187
		HIGH	NONE	—	—	29	45	28	123	31	45	30	125
			324A	4.9/6.5	13.6/15.6	48/48	60/60	44/46	137/139	50/50	60/60	46/48	139/141
			326A	7.9/10.5	21.9/25.3	61/61	70/70	53/57	145/148	63/63	70/70	55/59	147/150
			328A	12.0/16.0	33.4/38.5	77/77	80/80	66/72	156/162	79/79	80/80	69/75	158/164
			331A	15.8/21.0	43.8/50.5	92/92	100/100	78/86	167/174	94/94	100/100	81/88	169/176
			332A	18.4/24.5	51.1/58.9	103/103	110/110	87/96	174/182	105/105	110/110	89/98	176/184
	460-3-60	STD	NONE	—	—	17	25	15	56	18	25	16	57
			333A	6.0	7.2	26	30	24	63	27	30	25	64
			335A	11.5	13.8	34	40	31	70	35	40	32	71
			336A	14.0	16.8	38	40	35	73	39	40	36	74
			337A	21.5	25.9	49	50	45	82	50	50	46	83
			338A	24.0	28.9	53	60	49	85	54	60	50	86
		MED	NONE	—	—	17	25	16	57	18	25	17	58
			333A	6.0	7.2	26	30	24	64	27	30	25	65
			335A	11.5	13.8	34	40	32	71	35	40	33	72
			336A	14.0	16.8	38	40	35	74	39	45	36	75
			337A	21.5	25.9	49	50	46	83	50	50	47	84
			338A	24.0	28.9	53	60	49	86	54	60	50	87
		HIGH	NONE	—	—	18	25	17	58	19	25	18	59
			333A	6.0	7.2	27	30	25	65	28	30	26	66
			335A	11.5	13.8	35	40	33	72	36	40	34	73
			336A	14.0	16.8	39	45	36	75	40	45	37	76
			337A	21.5	25.9	50	50	47	84	51	60	48	85
			338A	24.0	28.9	54	60	50	87	55	60	51	88
	575-3-60	STD	NONE	—	—	13	20	12	43	15	20	14	45
			340A	15.0	14.4	31	35	29	57	33	35	31	59
			341A	21.0	20.2	38	40	35	63	40	40	37	65
		MED	NONE	—	—	13	20	12	44	15	20	14	46
			340A	15.0	14.4	31	35	29	58	33	35	31	60
			341A	21.0	20.2	38	40	36	64	40	40	38	66
		HIGH	NONE	—	—	14	20	13	45	16	20	15	47
			340A	15.0	14.4	32	35	30	59	34	35	32	61
			341A	21.0	20.2	39	40	36	65	41	45	39	67



50GCQM06 MCA MOC P ELECTRICAL DATA — WITH FACTORY-INSTALLED HACR BREAKER (cont)

50GCQ UNIT SIZE	NOM. V-Ph-Hz	IFM TYPE	ELECTRIC HEATER			w/ POWERED CONVENIENCE OUTLET								
			CRHEATER ****00	NOM (kW)	FLA	NO POWER EXHAUST				w/ POWER EXHAUST (powered from unit)				
						MCA	HACR BRKR	DISCONNECT SIZE		MCA	HACR BRKR	DISCONNECT SIZE		
								FLA	LRA			FLA	LRA	
M06	208/230-1-60	STD	NONE	—	—	—	—	—	—	—	—	—	—	—
			324A	4.9/6.5	23.5/27.1	—	—	—	—	—	—	—	—	—
			325A	6.5/8.7	31.4/36.3	—	—	—	—	—	—	—	—	—
			327A	9.8/13.0	46.9/54.2	—	—	—	—	—	—	—	—	—
			329A	13.1/17.4	62.8/72.5	—	—	—	—	—	—	—	—	—
		331A	15.8/21.0	75.8/87.5	—	—	—	—	—	—	—	—	—	
		MED	NONE	—	—	—	—	—	—	—	—	—	—	—
			324A	4.9/6.5	23.5/27.1	—	—	—	—	—	—	—	—	—
			325A	6.5/8.7	31.4/36.3	—	—	—	—	—	—	—	—	—
			327A	9.8/13.0	46.9/54.2	—	—	—	—	—	—	—	—	—
			329A	13.1/17.4	62.8/72.5	—	—	—	—	—	—	—	—	—
		331A	15.8/21.0	75.8/87.5	—	—	—	—	—	—	—	—	—	
		HIGH	NONE	—	—	—	—	—	—	—	—	—	—	—
			324A	4.9/6.5	23.5/27.1	—	—	—	—	—	—	—	—	—
			325A	6.5/8.7	31.4/36.3	—	—	—	—	—	—	—	—	—
	327A		9.8/13.0	46.9/54.2	—	—	—	—	—	—	—	—	—	
	329A		13.1/17.4	62.8/72.5	—	—	—	—	—	—	—	—	—	
	331A	15.8/21.0	75.8/87.5	—	—	—	—	—	—	—	—	—		
	208/230-3-60	STD	NONE	—	—	35	50	35	129	36	50	37	131	
			324A	4.9/6.5	13.6/15.6	54/54	60/60	50/52	143/145	56/56	60/60	52/55	145/147	
			326A	7.9/10.5	21.9/25.3	66/66	70/70	60/64	151/154	68/68	70/70	62/66	153/156	
			328A	12.0/16.0	33.4/38.5	83/83	90/90	73/79	162/168	85/85	90/90	75/81	164/170	
			331A	15.8/21.0	43.8/50.5	98/98	100/100	85/93	173/180	100/100	100/100	87/95	175/182	
		332A	18.4/24.5	51.1/58.9	108/108	110/110	93/102	180/188	110/110	110/110	95/104	182/190		
		MED	NONE	—	—	36	50	36	131	38	50	38	133	
			324A	4.9/6.5	13.6/15.6	55/55	60/60	52/54	145/147	57/57	60/60	54/56	147/149	
			326A	7.9/10.5	21.9/25.3	68/68	70/70	61/65	153/156	70/70	70/70	63/67	155/158	
			328A	12.0/16.0	33.4/38.5	84/84	90/90	75/80	164/170	86/86	90/90	77/83	166/172	
			331A	15.8/21.0	43.8/50.5	99/99	100/100	86/94	175/182	101/101	110/110	89/96	177/184	
		332A	18.4/24.5	51.1/58.9	110/110	110/110	95/104	182/190	112/112	125/125	97/106	184/192		
		HIGH	NONE	—	—	34	45	34	128	36	50	36	130	
			324A	4.9/6.5	13.6/15.6	53/53	60/60	49/52	142/144	55/55	60/60	51/54	144/146	
			326A	7.9/10.5	21.9/25.3	65/65	70/70	59/63	150/153	67/67	70/70	61/65	152/155	
	328A		12.0/16.0	33.4/38.5	82/82	90/90	72/78	161/167	84/84	90/90	74/80	163/169		
	331A		15.8/21.0	43.8/50.5	97/97	100/100	84/92	172/179	99/99	100/100	86/94	174/181		
	332A	18.4/24.5	51.1/58.9	107/107	110/110	92/101	179/187	109/109	110/110	95/104	181/189			
	460-3-60	STD	NONE	—	—	19	25	18	58	20	30	19	59	
			333A	6.0	7.2	28	30	26	65	29	30	27	66	
			335A	11.5	13.8	36	40	34	72	37	40	35	73	
			336A	14.0	16.8	40	45	37	75	41	45	38	76	
			337A	21.5	25.9	51	60	48	84	52	60	49	85	
		338A	24.0	28.9	55	60	51	87	56	60	52	88		
		MED	NONE	—	—	19	25	18	59	20	30	19	60	
			333A	6.0	7.2	28	30	27	66	29	30	28	67	
			335A	11.5	13.8	36	40	34	73	37	40	35	74	
336A			14.0	16.8	40	45	38	76	41	45	39	77		
337A			21.5	25.9	51	60	48	85	52	60	49	86		
338A		24.0	28.9	55	60	52	88	56	60	53	89			
HIGH		NONE	—	—	20	30	19	60	21	30	21	61		
		333A	6.0	7.2	29	30	28	67	30	35	29	68		
		335A	11.5	13.8	37	40	35	74	38	45	36	75		
	336A	14.0	16.8	41	45	39	77	42	45	40	78			
	337A	21.5	25.9	52	60	49	86	53	60	50	87			
338A	24.0	28.9	56	60	53	89	57	60	54	90				
575-3-60	STD	NONE	—	—	15	20	14	45	17	20	16	47		
		340A	15.0	14.4	33	35	30	59	35	35	33	61		
		341A	21.0	20.2	40	40	37	65	42	45	39	67		
	MED	NONE	—	—	15	20	14	46	17	20	16	48		
		340A	15.0	14.4	33	35	31	60	35	35	33	62		
	341A	21.0	20.2	40	40	37	66	42	45	40	68			
	HIGH	NONE	—	—	16	20	15	47	18	25	17	49		
340A		15.0	14.4	34	35	32	61	36	40	34	63			
341A	21.0	20.2	41	45	38	67	43	45	40	69				

50GCQM04 ELECTRIC HEAT DATA — WITHOUT NON-FUSED DISCONNECT

50GCQ UNIT SIZE	NOM. V-Ph-Hz	IFM TYPE	ELECTRIC HEATER PART NUMBER	NOM (kW)	APPLICATION (kW)	APPLICATION OUTPUT (MBH)	SINGLE POINT OR JUNCTION PART NUMBER CRSINGLEXXA00				
							NO C.O. OR UNPOWERED C.O.		w/PWRD C.O.		
							NO P.E.	w/P.E. (pwrd fr/unit)	NO P.E.	w/P.E. (pwrd fr/unit)	
M04	208/230-1-60	STD	CRHEATER323A00	4.4	3.3/4.0	11.3/13.8	—	—	—	—	
			CRHEATER324A00	6.5	4.9/6.0	16.7/20.4	037	037	—	—	
			CRHEATER325A00	8.7	6.5/8.0	22.3/27.3	040	040	—	—	
			CRHEATER326A00	10.5	7.9/9.6	26.9/32.9	040	040	—	—	
			CRHEATER327A00	13.0	9.8/11.9	33.3/40.7	041	041	—	—	
		MED	CRHEATER323A00	4.4	3.3/4.0	11.3/13.8	—	037	—	—	
			CRHEATER324A00	6.5	4.9/6.0	16.7/20.4	037	040	—	—	
			CRHEATER325A00	8.7	6.5/8.0	22.3/27.3	040	040	—	—	
			CRHEATER326A00	10.5	7.9/9.6	26.9/32.9	040	040	—	—	
			CRHEATER327A00	13.0	9.8/11.9	33.3/40.7	041	041	—	—	
		HIGH	CRHEATER323A00	4.4	3.3/4.0	11.3/13.8	037	037	—	—	
			CRHEATER324A00	6.5	4.9/6.0	16.7/20.4	040	040	—	—	
	CRHEATER325A00		8.7	6.5/8.0	22.3/27.3	040	040	—	—		
	CRHEATER326A00		10.5	7.9/9.6	26.9/32.9	040	040	—	—		
	CRHEATER327A00		13.0	9.8/11.9	33.3/40.7	041	041	—	—		
	208/230-3-60		STD	CRHEATER323A00	4.4	3.3/4.0	11.3/13.8	—	—	—	—
				CRHEATER324A00	6.5	4.9/6.0	16.7/20.4	—	—	—	—
				CRHEATER325A00	8.7	6.5/8.0	22.3/27.3	—	—	037	037
		CRHEATER326A00		10.5	7.9/9.6	26.9/32.9	037	037	037	037	
		CRHEATER328A00		16.0	12.0/14.7	41.0/50.1	038	038	038	038	
		MED	CRHEATER323A00	4.4	3.3/4.0	11.3/13.8	—	—	—	—	
			CRHEATER324A00	6.5	4.9/6.0	16.7/20.4	—	—	—	—	
			CRHEATER325A00	8.7	6.5/8.0	22.3/27.3	—	—	037	037	
			CRHEATER326A00	10.5	7.9/9.6	26.9/32.9	037	037	037	037	
		HIGH	CRHEATER328A00	16.0	12.0/14.7	41.0/50.1	038	038	038	038	
			CRHEATER323A00	4.4	3.3/4.0	11.3/13.8	—	—	—	—	
			CRHEATER324A00	6.5	4.9/6.0	16.7/20.4	—	—	—	—	
	CRHEATER325A00		8.7	6.5/8.0	22.3/27.3	—	037	037	037		
CRHEATER326A00	10.5		7.9/9.6	26.9/32.9	037	037	037	038			
460-3-60	STD	CRHEATER333A00	6.0	5.5	18.8	—	—	—	—		
		CRHEATER334A00	8.8	8.1	27.6	—	—	—	—		
		CRHEATER335A00	11.5	10.6	36.0	—	—	—	—		
		CRHEATER336A00	14.0	12.9	43.9	—	—	—	—		
	MED	CRHEATER333A00	6.0	5.5	18.8	—	—	—	—		
		CRHEATER334A00	8.8	8.1	27.6	—	—	—	—		
		CRHEATER335A00	11.5	10.6	36.0	—	—	—	—		
		CRHEATER336A00	14.0	12.9	43.9	—	—	—	—		
	HIGH	CRHEATER333A00	6.0	5.5	18.8	—	—	—	—		
		CRHEATER334A00	8.8	8.1	27.6	—	—	—	—		
		CRHEATER335A00	11.5	10.6	36.0	—	—	—	—		
		CRHEATER336A00	14.0	12.9	43.9	—	—	—	—		
575-3-60	STD	CRHEATER339A00	10.0	9.2	31.3	—	—	—	—		
		CRHEATER340A00	15.0	13.8	47.0	—	—	—	—		
	MED	CRHEATER339A00	10.0	9.2	31.3	—	—	—	—		
		CRHEATER340A00	15.0	13.8	47.0	—	—	—	—		
	HIGH	CRHEATER339A00	10.0	9.2	31.3	—	—	—	—		
		CRHEATER340A00	15.0	13.8	47.0	—	—	—	—		



50GCQM04 ELECTRIC HEAT DATA — WITH NON-FUSED DISCONNECT

50GCQ UNIT SIZE	NOM. V-Ph-Hz	IFM TYPE	ELECTRIC HEATER PART NUMBER	NOM (kW)	APPLICATION (kW)	APPLICATION OUTPUT (MBH)	SINGLE POINT OR JUNCTION PART NUMBER CRSINGLEXXA00			
							NO C.O. OR UNPOWERED C.O.		w/PWRD C.O.	
							NO P.E.	w/P.E. (pwrd fr/unit)	NO P.E	w/P.E. (pwrd fr/unit)
M04	208/230-1-60	STD	CRHEATER323A00	4.4	3.3/4.0	11.3/13.8	037	037	—	—
			CRHEATER324A00	6.5	4.9/6.0	16.7/20.4	037	037	—	—
			CRHEATER325A00	8.7	6.5/8.0	22.3/27.3	040	040	—	—
			CRHEATER326A00	10.5	7.9/9.6	26.9/32.9	040	040	—	—
			CRHEATER327A00	13.0	9.8/11.9	33.3/40.7	041	041	—	—
		MED	CRHEATER323A00	4.4	3.3/4.0	11.3/13.8	037	037	—	—
			CRHEATER324A00	6.5	4.9/6.0	16.7/20.4	037	040	—	—
			CRHEATER325A00	8.7	6.5/8.0	22.3/27.3	040	040	—	—
			CRHEATER326A00	10.5	7.9/9.6	26.9/32.9	040	040	—	—
			CRHEATER327A00	13.0	9.8/11.9	33.3/40.7	041	041	—	—
		HIGH	CRHEATER323A00	4.4	3.3/4.0	11.3/13.8	037	037	—	—
			CRHEATER324A00	6.5	4.9/6.0	16.7/20.4	040	040	—	—
			CRHEATER325A00	8.7	6.5/8.0	22.3/27.3	040	040	—	—
			CRHEATER326A00	10.5	7.9/9.6	26.9/32.9	040	040	—	—
			CRHEATER327A00	13.0	9.8/11.9	33.3/40.7	041	041	—	—
	208/230-3-60	STD	CRHEATER323A00	4.4	3.3/4.0	11.3/13.8	037	037	037	037
			CRHEATER324A00	6.5	4.9/6.0	16.7/20.4	037	037	037	037
			CRHEATER325A00	8.7	6.5/8.0	22.3/27.3	037	037	037	037
			CRHEATER326A00	10.5	7.9/9.6	26.9/32.9	037	037	037	037
			CRHEATER328A00	16.0	12.0/14.7	41.0/50.1	038	038	038	038
		MED	CRHEATER323A00	4.4	3.3/4.0	11.3/13.8	037	037	037	037
			CRHEATER324A00	6.5	4.9/6.0	16.7/20.4	037	037	037	037
			CRHEATER325A00	8.7	6.5/8.0	22.3/27.3	037	037	037	037
			CRHEATER326A00	10.5	7.9/9.6	26.9/32.9	037	037	037	037
			CRHEATER328A00	16.0	12.0/14.7	41.0/50.1	038	038	038	038
		HIGH	CRHEATER323A00	4.4	3.3/4.0	11.3/13.8	037	037	037	037
			CRHEATER324A00	6.5	4.9/6.0	16.7/20.4	037	037	037	037
			CRHEATER325A00	8.7	6.5/8.0	22.3/27.3	037	037	037	037
			CRHEATER326A00	10.5	7.9/9.6	26.9/32.9	037	037	037	038
			CRHEATER328A00	16.0	12.0/14.7	41.0/50.1	038	038	038	038
	460-3-60	STD	CRHEATER333A00	6.0	5.5	18.8	—	—	—	—
			CRHEATER334A00	8.8	8.1	27.6	—	—	—	—
			CRHEATER335A00	11.5	10.6	36.0	—	—	—	—
			CRHEATER336A00	14.0	12.9	43.9	—	—	—	—
		MED	CRHEATER333A00	6.0	5.5	18.8	—	—	—	—
			CRHEATER334A00	8.8	8.1	27.6	—	—	—	—
			CRHEATER335A00	11.5	10.6	36.0	—	—	—	—
			CRHEATER336A00	14.0	12.9	43.9	—	—	—	—
		HIGH	CRHEATER333A00	6.0	5.5	18.8	—	—	—	—
			CRHEATER334A00	8.8	8.1	27.6	—	—	—	—
CRHEATER335A00			11.5	10.6	36.0	—	—	—	—	
CRHEATER336A00			14.0	12.9	43.9	—	—	—	—	
575-3-60	STD	CRHEATER339A00	10.0	9.2	31.3	—	—	—	—	
		CRHEATER340A00	15.0	13.8	47.0	—	—	—	—	
	MED	CRHEATER339A00	10.0	9.2	31.3	—	—	—	—	
		CRHEATER340A00	15.0	13.8	47.0	—	—	—	—	
	HIGH	CRHEATER339A00	10.0	9.2	31.3	—	—	—	—	
		CRHEATER340A00	15.0	13.8	47.0	—	—	—	—	

50GCQM05 ELECTRIC HEAT DATA — WITHOUT NON-FUSED DISCONNECT

50GCQ UNIT SIZE	NOM. V-Ph-Hz	IFM TYPE	ELECTRIC HEATER PART NUMBER	NOM (kW)	APPLICATION (kW)	APPLICATION OUTPUT (MBH)	SINGLE POINT OR JUNCTION PART NUMBER CRSINGLEXXXA00			
							NO C.O. OR UNPOWERED C.O.		w/PWRD C.O.	
							NO P.E.	w/P.E. (pwrd fr/unit)	NO P.E	w/P.E. (pwrd fr/unit)
M05	208/230-1-60	STD	CRHEATER323A00	4.4	3.3/4.0	11.3/13.8	037	037	—	—
			CRHEATER325A00	8.7	6.5/8.0	22.3/27.3	040	040	—	—
			CRHEATER327A00	13.0	9.8/11.9	33.3/40.7	041	041	—	—
			CRHEATER329A00	17.4	13.1/16.0	44.6/54.5	041	041	—	—
			CRHEATER330A00	19.2	14.4/17.6	49.2/60.2	041	041	—	—
			CRHEATER331A00	21.0	15.8/19.3	53.8/65.8	041	041	—	—
		MED	CRHEATER323A00	4.4	3.3/4.0	11.3/13.8	037	037	—	—
			CRHEATER325A00	8.7	6.5/8.0	22.3/27.3	040	040	—	—
			CRHEATER327A00	13.0	9.8/11.9	33.3/40.7	041	041	—	—
			CRHEATER329A00	17.4	13.1/16.0	44.6/54.5	041	041	—	—
			CRHEATER330A00	19.2	14.4/17.6	49.2/60.2	041	041	—	—
			CRHEATER331A00	21.0	15.8/19.3	53.8/65.8	041	041	—	—
		HIGH	CRHEATER323A00	4.4	3.3/4.0	11.3/13.8	037	040	—	—
			CRHEATER325A00	8.7	6.5/8.0	22.3/27.3	040	040	—	—
			CRHEATER327A00	13.0	9.8/11.9	33.3/40.7	041	041	—	—
			CRHEATER329A00	17.4	13.1/16.0	44.6/54.5	041	041	—	—
			CRHEATER330A00	19.2	14.4/17.6	49.2/60.2	041	041	—	—
			CRHEATER331A00	21.0	15.8/19.3	53.8/65.8	041	041	—	—
	208/230-3-60	STD	CRHEATER323A00	4.4	3.3/4.0	11.3/13.8	—	—	—	—
			CRHEATER324A00	6.5	4.9/6.0	16.7/20.4	—	—	—	037
			CRHEATER325A00	8.7	6.5/8.0	22.3/27.3	037	037	037	037
			CRHEATER328A00	16.0	12.0/14.7	41.0/50.1	038	038	038	038
			CRHEATER330A00	19.2	14.4/17.6	49.2/60.2	039	039	039	039
			CRHEATER331A00	21.0	15.8/19.3	53.8/65.8	039	039	039	039
MED		CRHEATER323A00	4.4	3.3/4.0	11.3/13.8	—	—	—	—	
		CRHEATER324A00	6.5	4.9/6.0	16.7/20.4	—	—	037	037	
		CRHEATER325A00	8.7	6.5/8.0	22.3/27.3	037	037	037	037	
		CRHEATER328A00	16.0	12.0/14.7	41.0/50.1	038	038	038	038	
		CRHEATER330A00	19.2	14.4/17.6	49.2/60.2	039	039	039	039	
		CRHEATER331A00	21.0	15.8/19.3	53.8/65.8	039	039	039	039	
HIGH		CRHEATER323A00	4.4	3.3/4.0	11.3/13.8	—	—	—	—	
		CRHEATER324A00	6.5	4.9/6.0	16.7/20.4	—	—	—	037	
		CRHEATER325A00	8.7	6.5/8.0	22.3/27.3	037	037	037	037	
		CRHEATER328A00	16.0	12.0/14.7	41.0/50.1	038	038	038	038	
		CRHEATER330A00	19.2	14.4/17.6	49.2/60.2	039	039	039	039	
		CRHEATER331A00	21.0	15.8/19.3	53.8/65.8	039	039	039	039	
460-3-60	STD	CRHEATER333A00	6.0	5.5	18.8	—	—	—	—	
		CRHEATER335A00	11.5	10.6	36.0	—	—	—	—	
		CRHEATER336A00	14.0	12.9	43.9	—	—	—	—	
		CRHEATER337A00	21.5	19.7	67.4	037	037	037	037	
	MED	CRHEATER333A00	6.0	5.5	18.8	—	—	—	—	
		CRHEATER335A00	11.5	10.6	36.0	—	—	—	—	
		CRHEATER336A00	14.0	12.9	43.9	—	—	—	—	
		CRHEATER337A00	21.5	19.7	67.4	037	037	037	037	
	HIGH	CRHEATER333A00	6.0	5.5	18.8	—	—	—	—	
		CRHEATER335A00	11.5	10.6	36.0	—	—	—	—	
		CRHEATER336A00	14.0	12.9	43.9	—	—	—	—	
		CRHEATER337A00	21.5	19.7	67.4	037	037	037	037	
575-3-60	STD	CRHEATER339A00	10.0	9.2	31.3	—	—	—	—	
		CRHEATER340A00	15.0	13.8	47.0	—	—	—	—	
	MED	CRHEATER339A00	10.0	9.2	31.3	—	—	—	—	
		CRHEATER340A00	15.0	13.8	47.0	—	—	—	—	
	HIGH	CRHEATER339A00	10.0	9.2	31.3	—	—	—	—	
		CRHEATER340A00	15.0	13.8	47.0	—	—	—	—	



50GCQM05 ELECTRIC HEAT DATA — WITH NON-FUSED DISCONNECT

50GCQ UNIT SIZE	NOM. V-Ph-Hz	IFM TYPE	ELECTRIC HEATER PART NUMBER	NOM (kW)	APPLICATION (kW)	APPLICATION OUTPUT (MBH)	SINGLE POINT OR JUNCTION PART NUMBER CRSINGLEXXXXA00			
							NO C.O. OR UNPOWERED C.O.		w/PWRD C.O.	
							NO P.E.	w/P.E. (pwrd fr/unit)	NO P.E	w/P.E. (pwrd fr/unit)
M05	208/230-1-60	STD	CRHEATER323A00	4.4	3.3/4.0	11.3/13.8	037	037	—	—
			CRHEATER325A00	8.7	6.5/8.0	22.3/27.3	040	040	—	—
			CRHEATER327A00	13.0	9.8/11.9	33.3/40.7	041	041	—	—
			CRHEATER329A00	17.4	13.1/16.0	44.6/54.5	041	041	—	—
			CRHEATER330A00	19.2	14.4/17.6	49.2/60.2	041	041	—	—
		CRHEATER331A00	21.0	15.8/19.3	53.8/65.8	041	041	—	—	
		MED	CRHEATER323A00	4.4	3.3/4.0	11.3/13.8	037	037	—	—
			CRHEATER325A00	8.7	6.5/8.0	22.3/27.3	040	040	—	—
			CRHEATER327A00	13.0	9.8/11.9	33.3/40.7	041	041	—	—
			CRHEATER329A00	17.4	13.1/16.0	44.6/54.5	041	041	—	—
			CRHEATER330A00	19.2	14.4/17.6	49.2/60.2	041	041	—	—
		CRHEATER331A00	21.0	15.8/19.3	53.8/65.8	041	041	—	—	
	HIGH	CRHEATER323A00	4.4	3.3/4.0	11.3/13.8	037	040	—	—	
		CRHEATER325A00	8.7	6.5/8.0	22.3/27.3	040	040	—	—	
		CRHEATER327A00	13.0	9.8/11.9	33.3/40.7	041	041	—	—	
		CRHEATER329A00	17.4	13.1/16.0	44.6/54.5	041	041	—	—	
		CRHEATER330A00	19.2	14.4/17.6	49.2/60.2	041	041	—	—	
	CRHEATER331A00	21.0	15.8/19.3	53.8/65.8	041	041	—	—		
	208/230-3-60	STD	CRHEATER323A00	4.4	3.3/4.0	11.3/13.8	037	037	037	037
			CRHEATER324A00	6.5	4.9/6.0	16.7/20.4	037	037	037	037
			CRHEATER325A00	8.7	6.5/8.0	22.3/27.3	037	037	037	037
			CRHEATER328A00	16.0	12.0/14.7	41.0/50.1	038	038	038	038
			CRHEATER330A00	19.2	14.4/17.6	49.2/60.2	039	039	039	039
			CRHEATER331A00	21.0	15.8/19.3	53.8/65.8	039	039	039	039
MED		CRHEATER323A00	4.4	3.3/4.0	11.3/13.8	037	037	037	037	
		CRHEATER324A00	6.5	4.9/6.0	16.7/20.4	037	037	037	037	
		CRHEATER325A00	8.7	6.5/8.0	22.3/27.3	037	037	037	037	
		CRHEATER328A00	16.0	12.0/14.7	41.0/50.1	038	038	038	038	
		CRHEATER330A00	19.2	14.4/17.6	49.2/60.2	039	039	039	039	
		CRHEATER331A00	21.0	15.8/19.3	53.8/65.8	039	039	039	039	
HIGH		CRHEATER323A00	4.4	3.3/4.0	11.3/13.8	037	037	037	037	
		CRHEATER324A00	6.5	4.9/6.0	16.7/20.4	037	037	037	037	
		CRHEATER325A00	8.7	6.5/8.0	22.3/27.3	037	037	037	037	
		CRHEATER328A00	16.0	12.0/14.7	41.0/50.1	038	038	038	038	
		CRHEATER330A00	19.2	14.4/17.6	49.2/60.2	039	039	039	039	
		CRHEATER331A00	21.0	15.8/19.3	53.8/65.8	039	039	039	039	
460-3-60	STD	CRHEATER333A00	6.0	5.5	18.8	—	—	—	—	
		CRHEATER335A00	11.5	10.6	36.0	—	—	—	—	
		CRHEATER336A00	14.0	12.9	43.9	—	—	—	—	
		CRHEATER337A00	21.5	19.7	67.4	037	037	037	037	
	MED	CRHEATER333A00	6.0	5.5	18.8	—	—	—	—	
		CRHEATER335A00	11.5	10.6	36.0	—	—	—	—	
		CRHEATER336A00	14.0	12.9	43.9	—	—	—	—	
		CRHEATER337A00	21.5	19.7	67.4	037	037	037	037	
	HIGH	CRHEATER333A00	6.0	5.5	18.8	—	—	—	—	
		CRHEATER335A00	11.5	10.6	36.0	—	—	—	—	
		CRHEATER336A00	14.0	12.9	43.9	—	—	—	—	
		CRHEATER337A00	21.5	19.7	67.4	037	037	037	037	
575-3-60	STD	CRHEATER339A00	10.0	9.2	31.3	—	—	—	—	
		CRHEATER340A00	15.0	13.8	47.0	—	—	—	—	
	MED	CRHEATER339A00	10.0	9.2	31.3	—	—	—	—	
		CRHEATER340A00	15.0	13.8	47.0	—	—	—	—	
	HIGH	CRHEATER339A00	10.0	9.2	31.3	—	—	—	—	
		CRHEATER340A00	15.0	13.8	47.0	—	—	—	—	

50GCQM06 ELECTRIC HEAT DATA — WITHOUT NON-FUSED DISCONNECT

50GCQ UNIT SIZE	NOM. V-Ph-Hz	IFM TYPE	ELECTRIC HEATER PART NUMBER	NOM (kW)	APPLICATION (kW)	APPLICATION OUTPUT (MBH)	SINGLE POINT OR JUNCTION PART NUMBER CRSINGLEXEXXA00			
							NO C.O. OR UNPOWERED C.O.		w/PWRD C.O.	
							NO P.E.	w/P.E. (pwrd fr/unit)	NO P.E	w/P.E. (pwrd fr/unit)
M06	208/230-1-60	STD	CRHEATER324A00	6.5	4.9/6.0	16.7/20.4	040	040	—	—
			CRHEATER325A00	8.7	6.5/8.0	22.3/27.3	040	040	—	—
			CRHEATER327A00	13.0	9.8/11.9	33.3/40.7	041	041	—	—
			CRHEATER329A00	17.4	13.1/16.0	44.6/54.5	041	041	—	—
			CRHEATER331A00	21.0	15.8/19.3	53.8/65.8	041	041	—	—
		MED	CRHEATER324A00	6.5	4.9/6.0	16.7/20.4	040	040	—	—
			CRHEATER325A00	8.7	6.5/8.0	22.3/27.3	040	040	—	—
			CRHEATER327A00	13.0	9.8/11.9	33.3/40.7	041	041	—	—
			CRHEATER329A00	17.4	13.1/16.0	44.6/54.5	041	041	—	—
			CRHEATER331A00	21.0	15.8/19.3	53.8/65.8	041	041	—	—
		HIGH	CRHEATER324A00	6.5	4.9/6.0	16.7/20.4	040	040	—	—
			CRHEATER325A00	8.7	6.5/8.0	22.3/27.3	040	040	—	—
	CRHEATER327A00		13.0	9.8/11.9	33.3/40.7	041	041	—	—	
	CRHEATER329A00		17.4	13.1/16.0	44.6/54.5	041	041	—	—	
	CRHEATER331A00		21.0	15.8/19.3	53.8/65.8	041	041	—	—	
	208/230-3-60	STD	CRHEATER324A00	6.5	4.9/6.0	16.7/20.4	—	037	037	037
			CRHEATER326A00	10.5	7.9/9.6	26.9/32.9	038	038	038	038
			CRHEATER328A00	16.0	12.0/14.7	41.0/50.1	038	038	038	038
			CRHEATER331A00	21.0	15.8/19.3	53.8/65.8	039	039	039	039
			CRHEATER332A00	24.5	18.4/22.5	62.8/76.8	039	039	039	039
		MED	CRHEATER324A00	6.5	4.9/6.0	16.7/20.4	037	037	037	037
			CRHEATER326A00	10.5	7.9/9.6	26.9/32.9	038	038	038	038
			CRHEATER328A00	16.0	12.0/14.7	41.0/50.1	038	038	038	038
			CRHEATER331A00	21.0	15.8/19.3	53.8/65.8	039	039	039	039
			CRHEATER332A00	24.5	18.4/22.5	62.8/76.8	039	039	039	039
		HIGH	CRHEATER324A00	6.5	4.9/6.0	16.7/20.4	—	—	037	037
			CRHEATER326A00	10.5	7.9/9.6	26.9/32.9	038	038	038	038
	CRHEATER328A00		16.0	12.0/14.7	41.0/50.1	038	038	038	038	
CRHEATER331A00	21.0		15.8/19.3	53.8/65.8	039	039	039	039		
CRHEATER332A00	24.5		18.4/22.5	62.8/76.8	039	039	039	039		
460-3-60	STD	CRHEATER333A00	6.0	5.5	18.8	—	—	—	—	
		CRHEATER335A00	11.5	10.6	36.0	—	—	—	—	
		CRHEATER336A00	14.0	12.9	43.9	—	—	—	—	
		CRHEATER337A00	21.5	19.7	67.4	037	037	037	037	
		CRHEATER338A00	24.0	22.0	75.2	037	037	037	037	
	MED	CRHEATER333A00	6.0	5.5	18.8	—	—	—	—	
		CRHEATER335A00	11.5	10.6	36.0	—	—	—	—	
		CRHEATER336A00	14.0	12.9	43.9	—	—	—	—	
		CRHEATER337A00	21.5	19.7	67.4	037	037	037	037	
		CRHEATER338A00	24.0	22.0	75.2	037	037	037	037	
	HIGH	CRHEATER333A00	6.0	5.5	18.8	—	—	—	—	
		CRHEATER335A00	11.5	10.6	36.0	—	—	—	—	
		CRHEATER336A00	14.0	12.9	43.9	—	—	—	—	
		CRHEATER337A00	21.5	19.7	67.4	037	037	037	037	
		CRHEATER338A00	24.0	22.0	75.2	037	037	037	037	
575-3-60	STD	CRHEATER340A00	15.0	13.8	47.0	—	—	—	—	
		CRHEATER341A00	21.0	19.3	65.8	037	037	037	037	
	MED	CRHEATER340A00	15.0	13.8	47.0	—	—	—	—	
		CRHEATER341A00	21.0	19.3	65.8	037	037	037	037	
	HIGH	CRHEATER340A00	15.0	13.8	47.0	—	—	—	—	
		CRHEATER341A00	21.0	19.3	65.8	037	037	037	037	



50GCQM06 ELECTRIC HEAT DATA — WITH NON-FUSED DISCONNECT

50GCQ UNIT SIZE	NOM. V-Ph-Hz	IFM TYPE	ELECTRIC HEATER PART NUMBER	NOM (kW)	APPLICATION (kW)	APPLICATION OUTPUT (MBH)	SINGLE POINT OR JUNCTION PART NUMBER CRSINGLEXXXA00			
							NO C.O. OR UNPOWERED C.O.		w/PWRD C.O.	
							NO P.E.	w/P.E. (pwrd fr/unit)	NO P.E	w/P.E. (pwrd fr/unit)
M06	208/230-1-60	STD	CRHEATER324A00	6.5	4.9/6.0	16.7/20.4	040	040	—	—
			CRHEATER325A00	8.7	6.5/8.0	22.3/27.3	040	040	—	—
			CRHEATER327A00	13.0	9.8/11.9	33.3/40.7	041	041	—	—
			CRHEATER329A00	17.4	13.1/16.0	44.6/54.5	041	041	—	—
			CRHEATER331A00	21.0	15.8/19.3	53.8/65.8	041	041	—	—
		MED	CRHEATER324A00	6.5	4.9/6.0	16.7/20.4	040	040	—	—
			CRHEATER325A00	8.7	6.5/8.0	22.3/27.3	040	040	—	—
			CRHEATER327A00	13.0	9.8/11.9	33.3/40.7	041	041	—	—
			CRHEATER329A00	17.4	13.1/16.0	44.6/54.5	041	041	—	—
			CRHEATER331A00	21.0	15.8/19.3	53.8/65.8	041	041	—	—
		HIGH	CRHEATER324A00	6.5	4.9/6.0	16.7/20.4	040	040	—	—
			CRHEATER325A00	8.7	6.5/8.0	22.3/27.3	040	040	—	—
			CRHEATER327A00	13.0	9.8/11.9	33.3/40.7	041	041	—	—
			CRHEATER329A00	17.4	13.1/16.0	44.6/54.5	041	041	—	—
			CRHEATER331A00	21.0	15.8/19.3	53.8/65.8	041	041	—	—
	208/230-3-60	STD	CRHEATER324A00	6.5	4.9/6.0	16.7/20.4	—	037	037	037
			CRHEATER326A00	10.5	7.9/9.6	26.9/32.9	038	038	038	038
			CRHEATER328A00	16.0	12.0/14.7	41.0/50.1	038	038	038	038
			CRHEATER331A00	21.0	15.8/19.3	53.8/65.8	039	039	039	039
			CRHEATER332A00	24.5	18.4/22.5	62.8/76.8	039	039	039	039
		MED	CRHEATER324A00	6.5	4.9/6.0	16.7/20.4	037	037	037	037
			CRHEATER326A00	10.5	7.9/9.6	26.9/32.9	038	038	038	038
			CRHEATER328A00	16.0	12.0/14.7	41.0/50.1	038	038	038	038
			CRHEATER331A00	21.0	15.8/19.3	53.8/65.8	039	039	039	039
			CRHEATER332A00	24.5	18.4/22.5	62.8/76.8	039	039	039	039
		HIGH	CRHEATER324A00	6.5	4.9/6.0	16.7/20.4	—	—	037	037
			CRHEATER326A00	10.5	7.9/9.6	26.9/32.9	038	038	038	038
			CRHEATER328A00	16.0	12.0/14.7	41.0/50.1	038	038	038	038
			CRHEATER331A00	21.0	15.8/19.3	53.8/65.8	039	039	039	039
			CRHEATER332A00	24.5	18.4/22.5	62.8/76.8	039	039	039	039
	460-3-60	STD	CRHEATER333A00	6.0	5.5	18.8	—	—	—	—
			CRHEATER335A00	11.5	10.6	36.0	—	—	—	—
			CRHEATER336A00	14.0	12.9	43.9	—	—	—	—
			CRHEATER337A00	21.5	19.7	67.4	037	037	037	037
			CRHEATER338A00	24.0	22.0	75.2	037	037	037	037
		MED	CRHEATER333A00	6.0	5.5	18.8	—	—	—	—
			CRHEATER335A00	11.5	10.6	36.0	—	—	—	—
			CRHEATER336A00	14.0	12.9	43.9	—	—	—	—
			CRHEATER337A00	21.5	19.7	67.4	037	037	037	037
			CRHEATER338A00	24.0	22.0	75.2	037	037	037	037
HIGH		CRHEATER333A00	6.0	5.5	18.8	—	—	—	—	
		CRHEATER335A00	11.5	10.6	36.0	—	—	—	—	
		CRHEATER336A00	14.0	12.9	43.9	—	—	—	—	
		CRHEATER337A00	21.5	19.7	67.4	037	037	037	037	
		CRHEATER338A00	24.0	22.0	75.2	037	037	037	037	
575-3-60	STD	CRHEATER340A00	15.0	13.8	47.0	—	—	—	—	
		CRHEATER341A00	21.0	19.3	65.8	037	037	037	037	
	MED	CRHEATER340A00	15.0	13.8	47.0	—	—	—	—	
		CRHEATER341A00	21.0	19.3	65.8	037	037	037	037	
	HIGH	CRHEATER340A00	15.0	13.8	47.0	—	—	—	—	
		CRHEATER341A00	21.0	19.3	65.8	037	037	037	037	

TYPICAL CONTROL WIRING DIAGRAM — 50GCQM04-06 208/230-3-60 UNIT WITH ELECTRO-MECHANICAL CONTROL AND W7220 ECONOMIZER

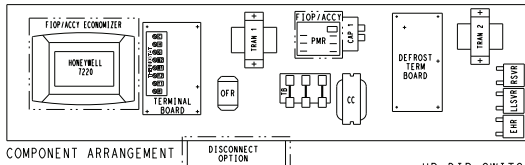

- NOTES:**
1. TERMINAL BOARD SCHEMATIC LAYOUT DOES NOT MATCH ACTUAL TERMINAL BOARD LAYOUT.
 2. TERMINAL BOARD JUMPERS 1, 2 AND 3 ARE CUT FOR HEATPUMP UNITS.
 3. REMOVE DESIGNATED JUMPERS ON TERMINAL BOARD WHEN ADDING SMOKE DETECTORS, OCCUPANCY AND REMOTE SHUTDOWN.
 4. USE ABC AS COARSE AND AS NOT FINE ADJUSTMENTS FOR SETTING HIGH FAN SPEED. LOW SPEED IS AN OFFSET BASED ON DIP SWITCHES.
 5. 2-PIN LOW SPEED DIP SWITCH POSITIONS ARE FACTORY SET AS SHOWN.
 6. HARDBLAST AND CUTOFF SET TO "MIN". JUMPER PIN ON TOP 2-PINS AS SHOWN.
 7. * WIRE COLOR IS FOR DIFFERENTIATION WITHIN THIS SCHEMATIC.
 8. COMPRESSOR LEADER PLUG CONTAINS BRIDGE RECTIFIER TO CONVERT AC TO DC.
 9. TBA LOCATED IN HEAT SECTION.
 10. TO CONVERT TO A SINGLE STAGE HEATER MOVE VIOLET WIRE AT TBA TO CONNECT WITH WHITE WIRE.
 11. ON 3 & 5 TON UNITS, PNK FROM HPC CONNECTS DIRECTLY TO YEL FROM PIN ②

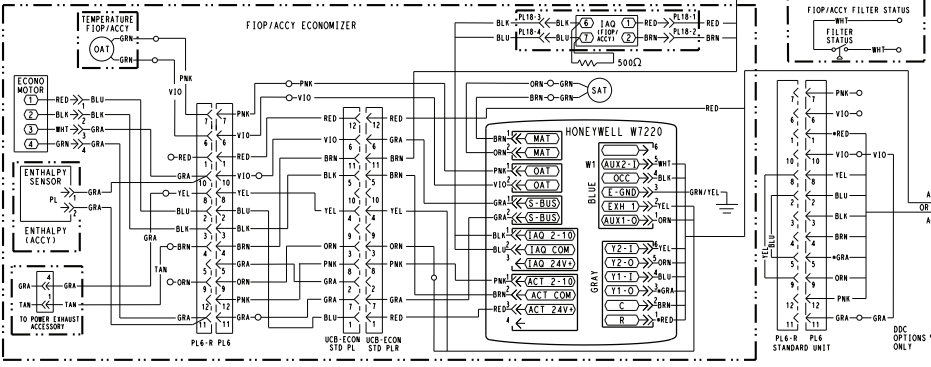
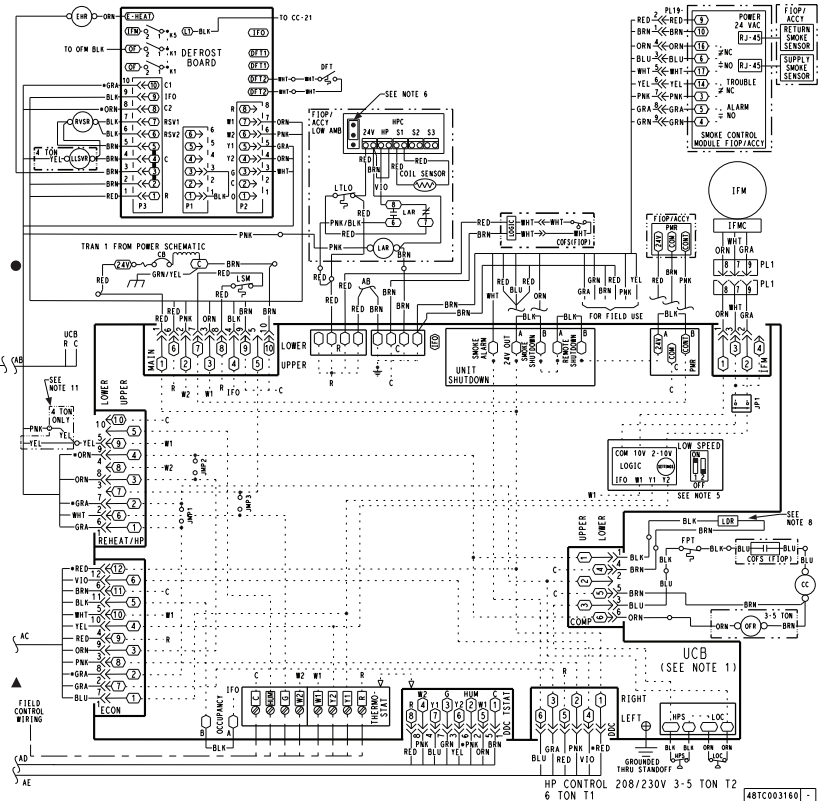
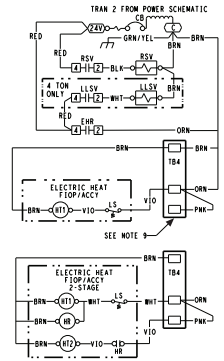
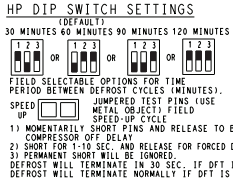

TYPICAL CONTROL WIRING DIAGRAM — 50GCQM04-06 460/575-3-60 UNIT WITH ELECTRO-MECHANICAL CONTROL AND W7220 ECONOMIZER

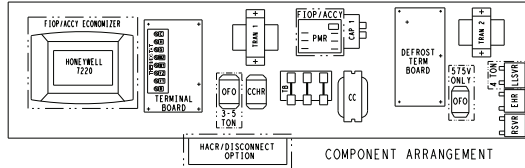

- NOTES:**
1. TERMINAL BOARD SCHEMATIC LAYOUT DOES NOT MATCH ACTUAL TERMINAL BOARD LAYOUT.
 2. TERMINAL BOARD JUMPERS 1, 2 AND 9 ARE CUT FOR REHEAT UNITS ONLY.
 3. REMOVE DESIGNATED JUMPERS ON TERMINAL BOARD WHEN ADDING SMOKE DETECTORS, OCCUPANCY AND REMOTE SHUTDOWN.
 4. USE ABC AS COURSE AND POT AS FINE ADJUSTMENTS FOR SETTING HIGH FAN SPEED. LOW SPEED IS AN OFFSET BASED ON DIP SWITCHES.
 5. 2-PIN LOW SPEED DIP SWITCH POSITIONS ARE FACTORY SET AS SHOWN.
 6. HARDSTART AND CUTOFF SET TO "MIN". JUMPER PIN ON TOP 2-PINS AS SHOWN.
 7. THE "W" WIRE COLOR IS FOR DIFFERENTIATION WITHIN THIS SCHEMATIC.
 8. COMPRESSOR LOWER PULG CONTAINS BRIDGE RECTIFIER TO CONVERT AC TO DC.
 9. TB4 LOCATED IN HEAT SECTION.
 10. TO CONVERT TO A SINGLE STAGE HEATER MOVE VIOLET WIRE AT TB4 TO CONNECT WITH WHITE WIRE.
 11. ON 3 & 5 TON UNITS, PAK FROM HPC CONNECTS DIRECTLY TO YEL FROM PIN ②

HP DIP SWITCH SETTINGS



FIELD SELECTABLE OPTIONS FOR TIME PERIOD BETWEEN DEFROST CYCLES (MINUTES).

SPEED JUMPERED TEST PINS (USE UP METAL OBJECT) FIELD SPEED-UP CYCLE

1. MOMENTARILY SHORT PINS AND RELEASE TO BYPASS COMPRESSOR OFF DELAY.
 2. SHORT FOR 1-10 SEC. AND RELEASE FOR FORCED DEFROST.
 3. PERMANENT SHORT WILL BE IGNORED.
- DEFROST WILL TERMINATE IN 30 SEC. IF DFT IS OPEN. DEFROST WILL TERMINATE NORMALLY IF DFT IS CLOSED.

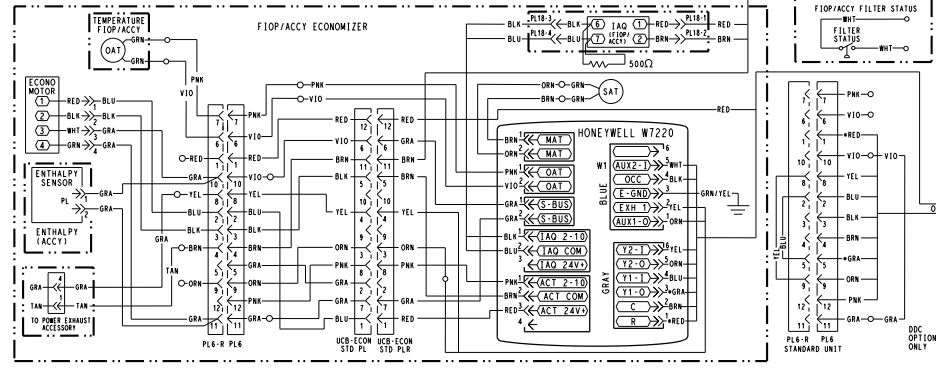
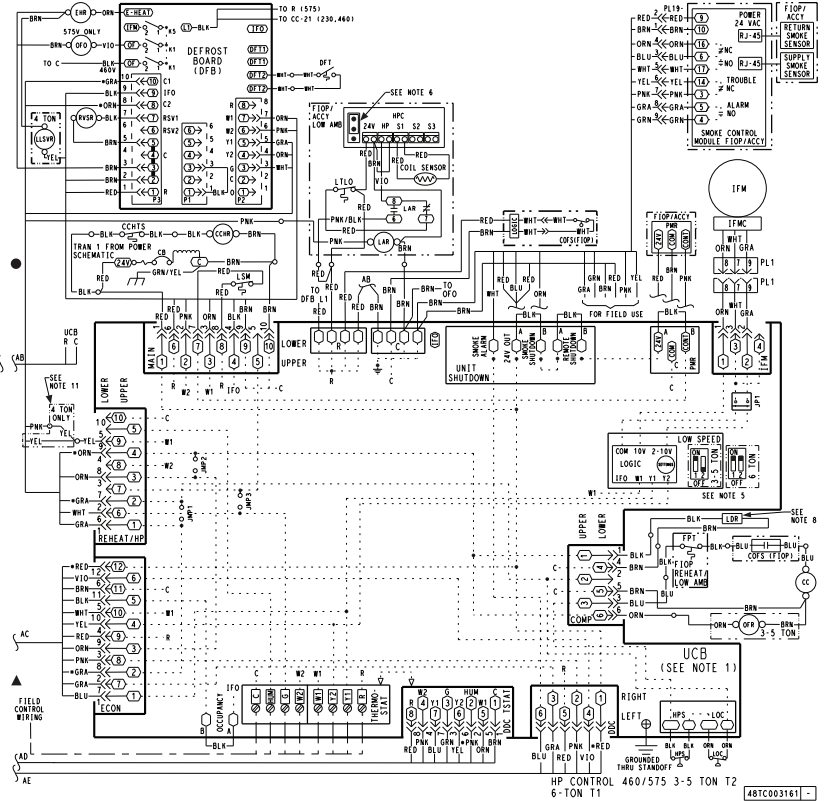
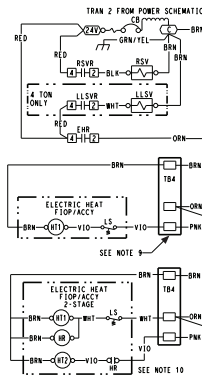

TYPICAL CONTROL WIRING DIAGRAM — 50GCQM04-06 208/230, 460, 575-3-60 UNIT WITH SYSTEMVU™ CONTROLLER

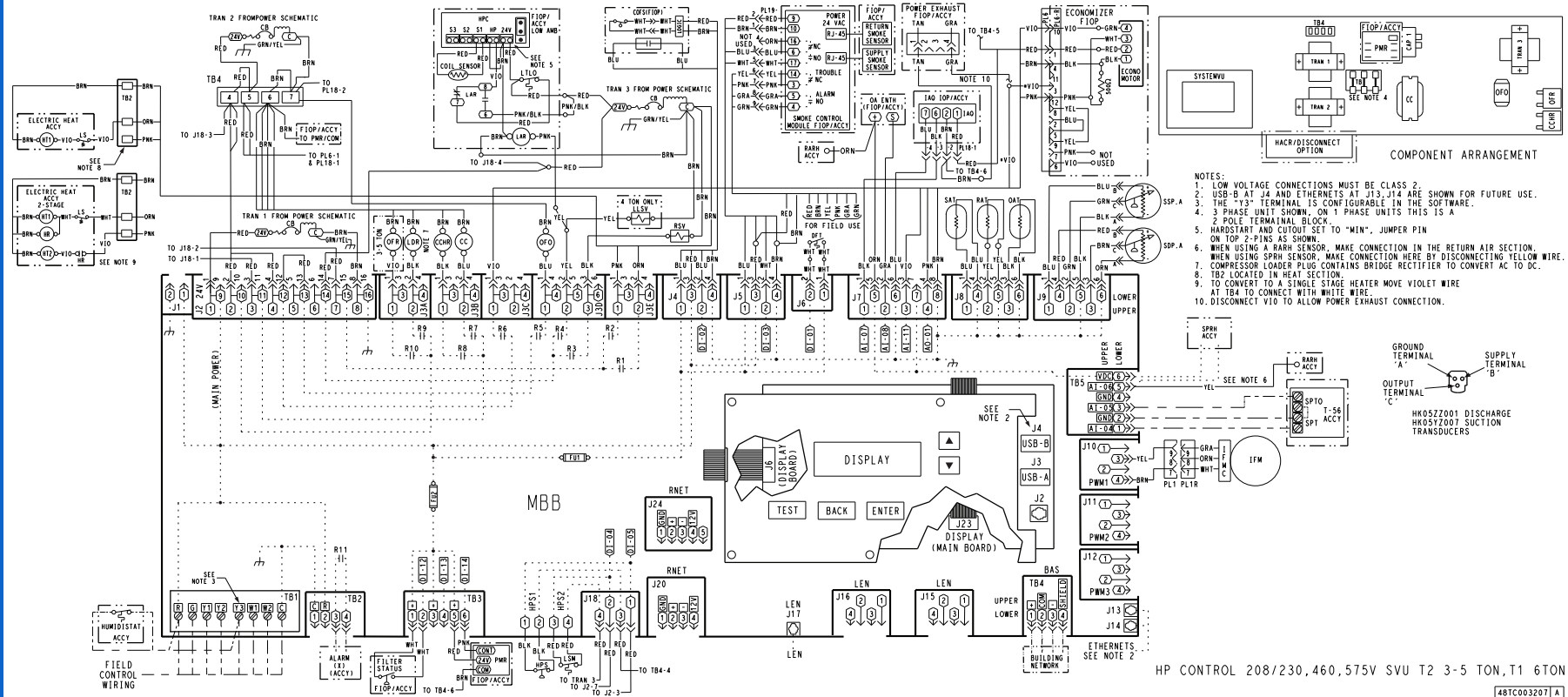

TYPICAL CONTROL WIRING DIAGRAM — 50GCQM04-06 208/230-3-60 UNIT WITH RTU OPEN CONTROLLER

48TC003214 HP 3-5 TON T2 & 3-6 TON T1 208/230,460,575V RTU OPEN

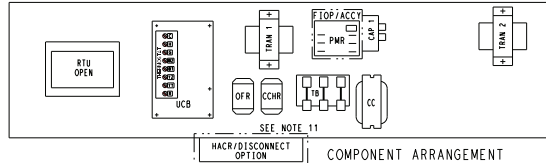

- NOTES:
1. TERMINAL BOARD SCHEMATIC LAYOUT DOES NOT MATCH ACTUAL TERMINAL BOARD LAYOUT.
 2. TERMINAL BOARD JUMPERS 1, 2, AND 3 ARE CUT FOR REHEAT UNITS ONLY.
 3. REMOVE DESIGNATED JUMPERS ON TERMINAL BOARD WHEN ADDING SMOKE DETECTORS, OCCUPANCY AND REMOTE SHUTDOWN.
 4. NOT USED ON RTU OPEN.
 5. USE RTU OPEN SETTING TO ADJUST FAN SPEED.
 6. HARDSTART AND CUTOFF SET TO "MEN" - JUMPER PIN ON TOP 2-PINS AS SHOWN.
 7. THE WIRE COLOR IS FOR DIFFERENTIATION WITHIN THIS SCHEMATIC.
 8. COMPRESSOR LEADER PLUG CONTAINS BRIDGE RECTIFIER TO CONVERT AC TO DC.
 9. T84 LOCKED IN THE HEAT SECTION.
 10. TO CONVERT TO A SINGLE STAGE HEATER MOVE VIOLET WIRE AT T84 TO CONNECT WITH WHITE WIRE.
 11. COMPONENTS MAY VARY BASED ON EXACT PRODUCT AND OPTIONS.
 12. FOLLOW THIS WIRING FOR IFM CONNECTOR WITH RTU OPEN. IGNORE IFM WIRING AT UCB.

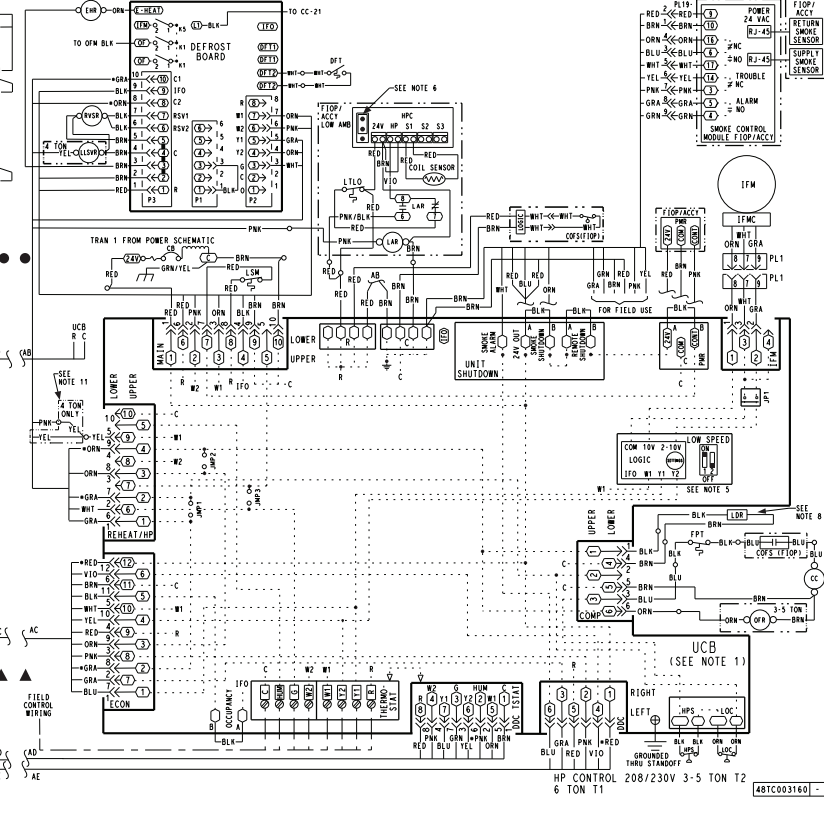
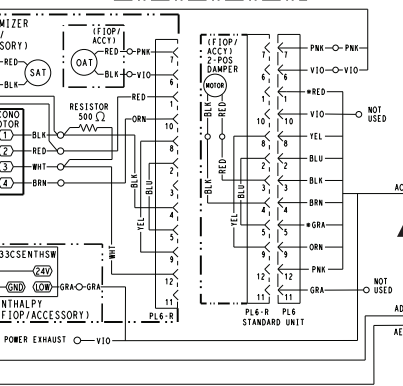
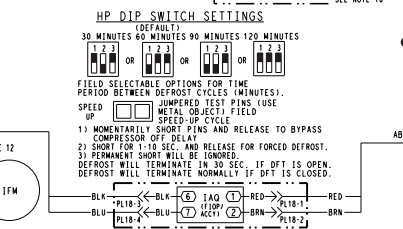
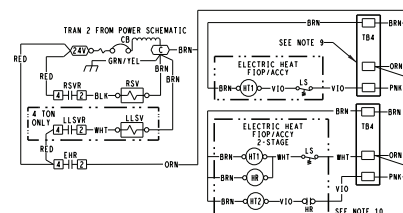
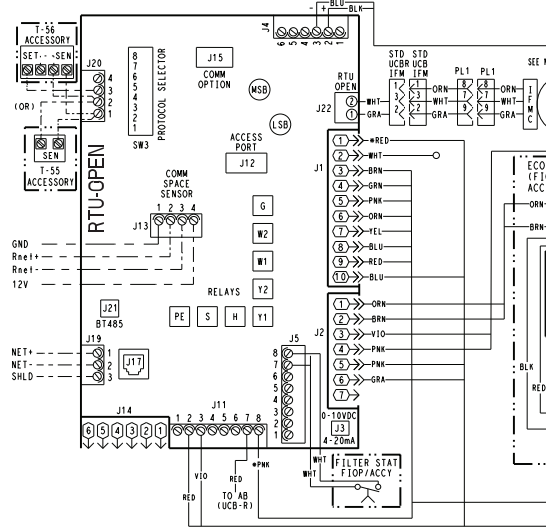

TYPICAL CONTROL WIRING DIAGRAM — 50GCQM04-06 460/575-3-60 UNIT WITH RTU OPEN CONTROLLER

48TC003214 - HP 3-5 TON T2 & 3-6 TON T1 208/230,460,575V RTU OPEN

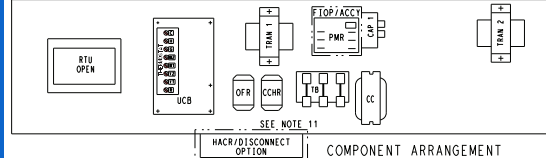

- NOTES:**
- TERMINAL BOARD SCHEMATIC LAYOUT DOES NOT MATCH ACTUAL TERMINAL BOARD LAYOUT.
 - TERMINAL BOARD JUMPERS 1, 2 AND 3 ARE CUT FOR REHEAT UNITS ONLY.
 - REMOVE DESIGNATED JUMPERS ON TERMINAL BOARD WHEN ADDING SMOKE DETECTORS, OCCUPANCY AND REMOTE SHUTDOWN.
 - NOT USED ON RTU OPEN.
 - USE RTU OPEN SETTING TO ADJUST FAN SPEED.
 - HARDSTART AND CUTOFF SET TO "MIN". JUMPER PIN ON TOP 2-PINS AS SHOWN.
 - THE * WIRE COLOR IS FOR DIFFERENTIATION WITHIN THIS SCHEMATIC.
 - COMPRESSOR LOADER PLUG CONTAINS BRIDGE RECTIFIER TO CONVERT AC TO DC.
 - TRN 1 LOCATED IN THE HEAT SECTION.
 - TO CONVERT TO A SINGLE STAGE HEATER MOVE VIOLET WIRE AT TB4 TO CONNECT WITH WHITE WIRE.
 - COMPONENTS MAY VARY BASED ON EXACT PRODUCT AND OPTIONS.
 - FOLLOW THIS WIRING FOR IFM CONNECTOR WITH RTU OPEN. IGNORE IFM WIRING AT UCB.

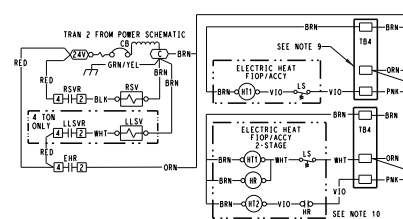

HP DIP SWITCH SETTINGS

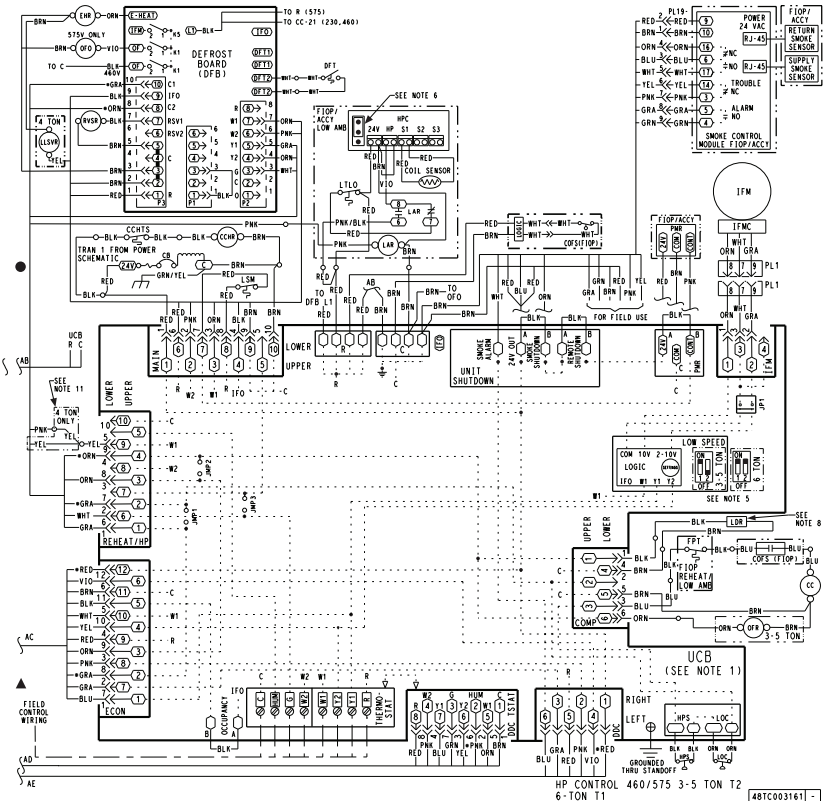
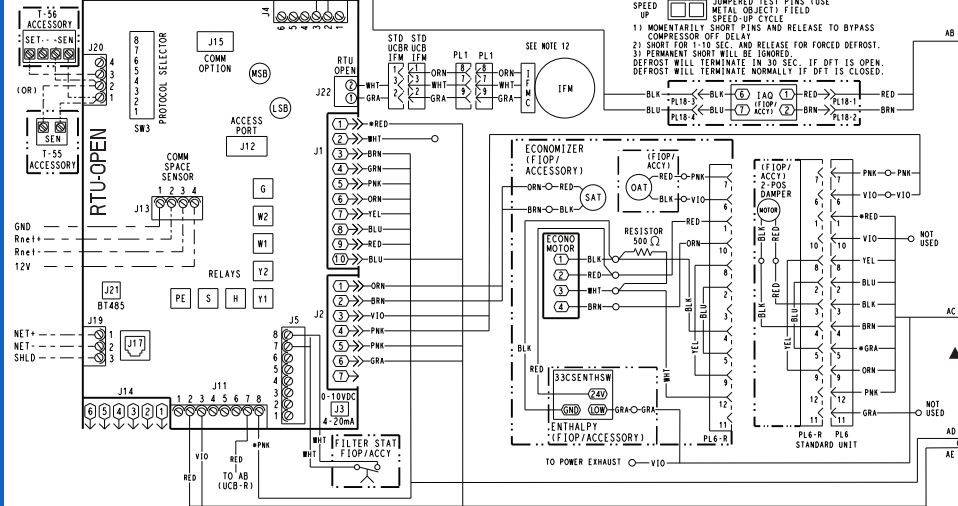

TYPICAL 50GCQM04-06 POWER WIRING DIAGRAM, 208/230-3-60 UNIT SHOWN

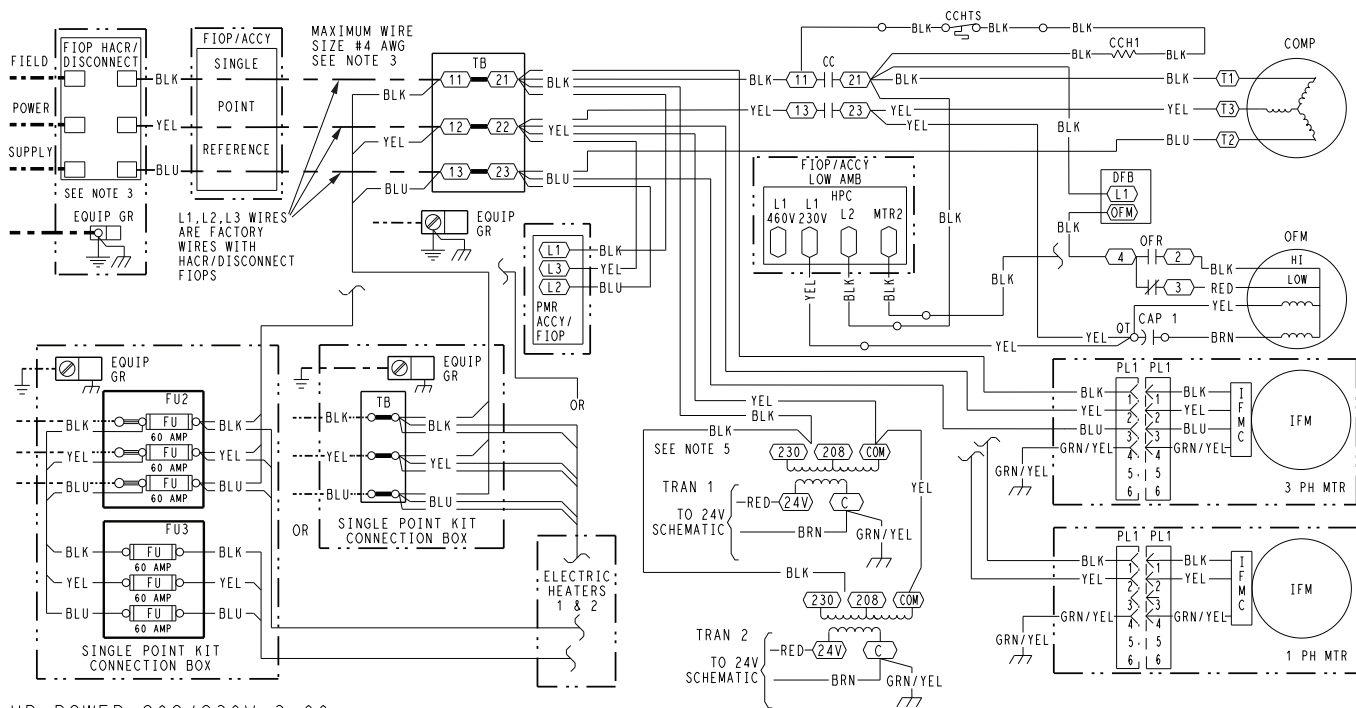

HP POWER 208/230V-3-60
3-5TON T2

- NOTES**
- IF ANY OF THE ORIGINAL WIRE FURNISHED MUST BE REPLACED, IT MUST BE REPLACED WITH TYPE 90° C WIRE OR ITS EQUIVALENT.
 - COMPRESSOR AND FAN MOTORS ARE THERMALLY PROTECTED.
 - USE COPPER CONDUCTOR ONLY.
 - DO NOT DISCONNECT POWER PLUG OR SIGNAL WIRE WHILE UNDER LOAD.
 - ON 208/230V UNITS, TRAN IS WIRED FOR 230V. IF UNIT IS TO BE RUN WITH 208V POWER SUPPLY, DISCONNECT BLK WIRE FROM 230V TAP AND CONNECT TO 208V TAP.

LEGEND

(X)	MARKED WIRE
(X)	TERMINAL (MARKED)
(O)	TERMINAL (UNMARKED)
[]	TERMINAL BLOCK
•	SPLICE
○	SPLICE (MARKED)
---	FACTORY WIRING
- - -	FIELD CONTROL WIRING
- - - -	FIELD POWER WIRING
· · · · ·	CIRCUIT BOARD TRACE
- · - · -	ACCESSORY OR OPTIONAL WIRING

ACCY	ACCESSORY	G	THERMOSTAT FAN CALL
AWG	AMERICAN WIRE GAGE	GR(ND)	GROUND
BAS	BUILDING AUTOMATION NETWORK	HACR	HEATING, AIR-CONDITIONING, REFRIGERATION BREAKER
CC	CONTACTOR, COMPRESSOR	C	COMMON
C	COMMON	CAP	CAPACITOR
CAP	CAPACITOR	CB	CIRCUIT BREAKER
CB	CIRCUIT BREAKER	CCH	CRANKCASE HEATER
CCH	CRANKCASE HEATER	CCHR	CRANKCASE HEATER RELAY
CCHR	CRANKCASE HEATER RELAY	CCHTS	CRANKCASE HEATER TEMP SWITCH
CCHTS	CRANKCASE HEATER TEMP SWITCH	CLO	COMPRESSOR LOCKOUT
CLO	COMPRESSOR LOCKOUT	CLV	COOLING LIQUID VALVE
CLV	COOLING LIQUID VALVE	COFS	CONDENSATE OVERFLOW SWITCH
COFS	CONDENSATE OVERFLOW SWITCH	COM	SIGNAL COMMON
COM	SIGNAL COMMON	COMP	COMPRESSOR MOTOR
COMP	COMPRESSOR MOTOR	DDC	DIRECT DIGITAL CONTROL
DDC	DIRECT DIGITAL CONTROL	DFB	DEFROST BOARD
DFB	DEFROST BOARD	DFT	DEFROST THERMOSTAT
DFT	DEFROST THERMOSTAT	EHR	ELECTRIC HEAT RELAY
EHR	ELECTRIC HEAT RELAY	ENTH	ENTHALPY
ENTH	ENTHALPY	ERV	ENERGY RECOVERY VENTILATOR
ERV	ENERGY RECOVERY VENTILATOR	ESL	ENTHALPY SENSOR - LOW
ESL	ENTHALPY SENSOR - LOW	FB	FUSE BLOCK
FB	FUSE BLOCK	FIOp	FACTORY INSTALLED OPTION
FIOp	FACTORY INSTALLED OPTION	FPT	FREEZE PROTECTION THERMOSTAT
FPT	FREEZE PROTECTION THERMOSTAT	FST	FAN HOUSING TEMP SENSOR
FST	FAN HOUSING TEMP SENSOR	FU	FUSE
FU	FUSE		

MBO	MAIN BASE BOARD	6	THERMOSTAT FAN CALL
MOV	METAL OXIDE VARISTOR	GR(ND)	GROUND
MTR	MOTOR	HACR	HEATING, AIR-CONDITIONING, REFRIGERATION BREAKER
OAO	OUTDOOR AIR QUALITY	C	COMMON
OAT	OUTDOOR AIR TEMP. SEN	HR	HEATER RELAY
OFM	OUTDOOR FAN MOTOR	HGRH	HOT GAS REHEAT
OFR	OUTDOOR FAN RELAY	HPC	HEAD PRESSURE CONTROL
OL	OVERLOAD	HPS	HIGH PRESSURE SWITCH
PER	POWER EXHAUST RELAY	IAO	INDOOR AIR QUALITY SENSORS
PH	PHASE	IFM	INDOOR FAN MOTOR
PL	PLUG ASSEMBLY	IFMC	INDOOR FAN MOTOR CONTROL
POT	POTENTIOMETER	IFO	INDOOR FAN ON SIGNAL
PMR	PHASE MONITOR RELAY	IRH	INDOOR RELATIVE HUMIDITY
PS	PRESSURE SWITCH	JMP	JUMPER
PWM	PULSE WIDTH MODULATION	L1	LINE 1
Q	QUADRUPLE TERMINAL	LA	LOW AMBIENT LOCKOUT
R	THERMOSTAT POWER	LAR	LOW AMBIENT RELAY
RAT	RETURN AIR TEMP. SENSOR	LAS	LOW AMBIENT SWITCH
RLV	REHEAT LIQUID VALVE	LDR	COMPRESSOR LOADER
RNET	LOCAL ACCESS NETWORK	LEN	LOCAL EQUIPMENT NETWORK
RVS	REVERSING VALVE SOLENOID	LLSVR	LIQUID LINE SOLENOID VALVE
SAT	SUPPLY AIR TEMP SENSOR	LOC	LOSS OF CHARGE
SDP	SYSTEM DISCHARGE PRESSURE	LOOP	CURRENT LOOP POWER
SPT	SPACE TEMPERATURE SENSOR	LPS	LOW PRESSURE SWITCH
SPTO	SPACE TEMPERATURE OFFSET	LS	LIMIT SWITCH
SSP	SYSTEM SUCTION PRESSURE	LSM	LIMIT SWITCH (MANUAL RESET)
SW	SWITCH	LTO	LOW TEMP LOCKOUT
TB	TERMINAL BLOCK		
TDR	TIME DELAY RELAY		
TRAN	TRANSFORMER		
UCB	UNIT CONTROL BOARD		
W1	1st STAGE OF HEATING CALL		
W2	2nd STAGE OF HEATING CALL		
Y1	1st STAGE OF COOLING CALL		
Y2	2nd STAGE OF COOLING CALL		

48TC003156 -

TYPICAL 50GCQM04-06 POWER WIRING DIAGRAM, 460/575-3-60 UNIT SHOWN

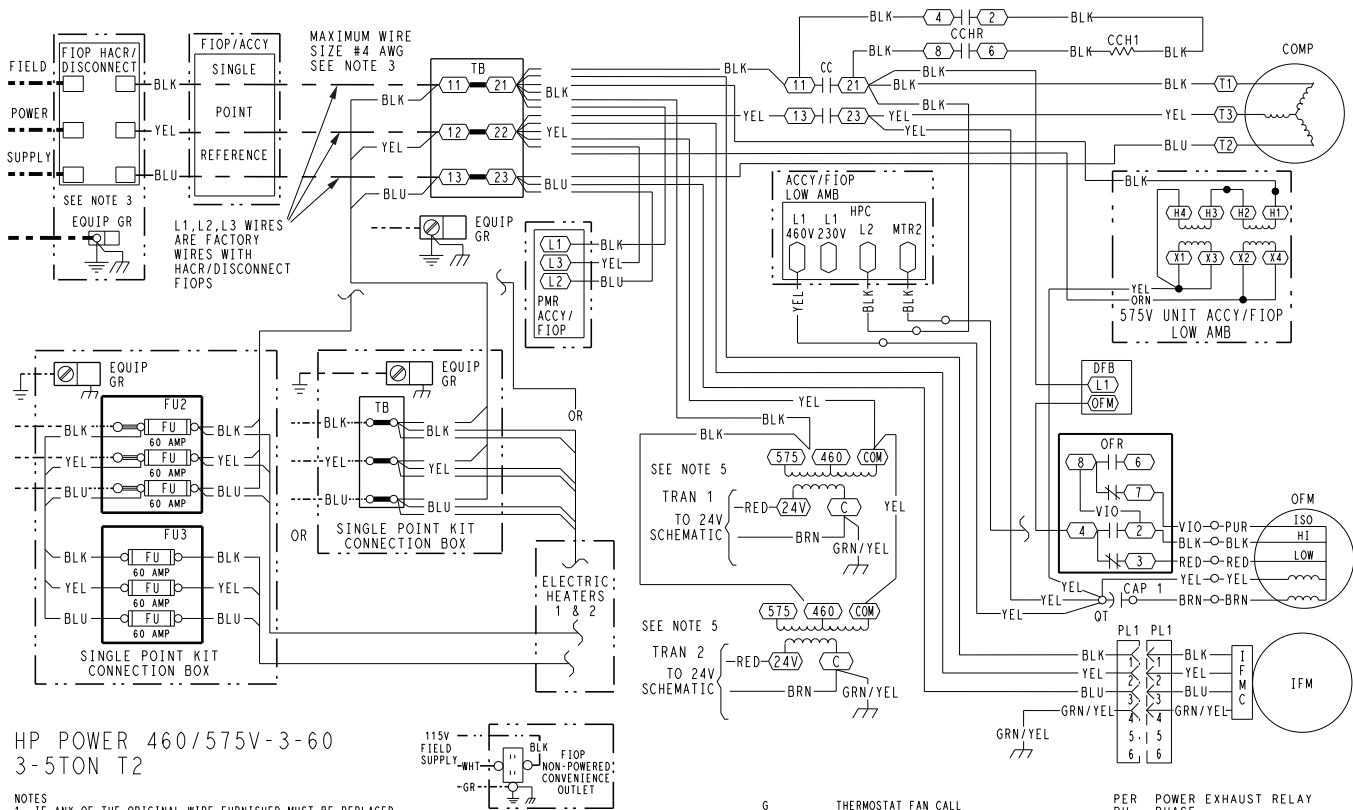

HP POWER 460/575V-3-60
3-5TON T2

- NOTES**
- IF ANY OF THE ORIGINAL WIRE FURNISHED MUST BE REPLACED. IT MUST BE REPLACED WITH TYPE 90° C WIRE OR ITS EQUIVALENT.
 - COMPRESSOR AND FAN MOTORS ARE THERMALLY PROTECTED.
 - USE COPPER CONDUCTOR ONLY.
 - DO NOT DISCONNECT POWER PLUG OR SIGNAL WIRE WHILE UNDER LOAD.
 - TRANSFORMER IS DEDICATED BASED ON UNIT VOLTAGE. TAPS ONLY SHOWN TO SIMPLIFY SCHEMATIC.

LEGEND

- (X) MARKED WIRE
- (X) TERMINAL (MARKED)
- () TERMINAL (UNMARKED)
- (X) TERMINAL BLOCK
- SPLICE
- SPLICE (MARKED)
- FACTORY WIRING
- - - FIELD CONTROL WIRING
- - - FIELD POWER WIRING
- - - - - CIRCUIT BOARD TRACE
- - - - - ACCESSORY OR OPTIONAL WIRING

- ACCY ACCESSORY
- AWG AMERICAN WIRE GAGE
- BAS BUILDING AUTOMATION NETWORK
- CC CONTACTOR, COMPRESSOR
- C COMMON
- CAP CAPACITOR
- CB CIRCUIT BREAKER
- CCH CRANKCASE HEATER
- CCHR CRANKCASE HEATER RELAY
- CCHTS CRANKCASE HEATER TEMP SWITCH
- CLO COMPRESSOR LOCKOUT
- CLV COOLING LIQUID VALVE
- COFS CONDENSATE OVERFLOW SWITCH
- COM SIGNAL COMMON
- COM COMPRESSOR MOTOR
- DDC DIRECT DIGITAL CONTROL
- DFB DEFROST BOARD
- DFT DEFROST THERMOSTAT
- EHR ELECTRIC HEAT RELAY
- ENTH ENTHALPY
- ERV ENERGY RECOVERY VENTILATOR
- ESL ENTHALPY SENSOR - LOW
- FB FUSE BLOCK
- FIOF FACTORY INSTALLED OPTION
- FPT FREEZE PROTECTION THERMOSTAT
- FST FAN HOUSING TEMP SENSOR
- FU FUSE

- G GR(ND)
- HACR HEATING, AIR-CONDITIONING, REFRIGERATION BREAKER
- HR HEATER RELAY
- HGRH HOT GAS REHEAT
- HPC HEAD PRESSURE CONTROL
- HPS HIGH PRESSURE SWITCH
- HUM HUMIDISTAT
- IAO INDOOR AIR QUALITY SENSORS
- IFM INDOOR FAN MOTOR
- IFMC INDOOR FAN MOTOR CONTROL
- IFO INDOOR FAN ON SIGNAL
- IRH INDOOR RELATIVE HUMIDITY
- JMP JUMPER
- LINE 1 LINE 1
- LA LOW AMBIENT LOCKOUT
- LAR LOW AMBIENT RELAY
- LAS LOW AMBIENT SWITCH
- LDR COMPRESSOR LOADER
- LEN LOCAL EQUIPMENT NETWORK
- LOC LOSS OF CHARGE
- LOOP CURRENT LOOP POWER
- LPS LOW PRESSURE SWITCH
- LS LIMIT SWITCH
- LMO LIMIT SWITCH (MANUAL RESET)
- LTLW LOW TEMP LOCKOUT
- MBS MAIN BASE BOARD
- MOV METAL OXIDE VARISTOR
- MTR MOTOR
- OAQ OUTDOOR AIR QUALITY
- OAT OUTDOOR AIR TEMP. SEN
- OFM OUTDOOR FAN MOTOR
- OFR OUTDOOR FAN RELAY
- OL OVERLOAD

- PER POWER EXHAUST RELAY
- PH PHASE
- PL PLUG ASSEMBLY
- POT POTENTIOMETER
- PMR PHASE MONITOR RELAY
- PS PRESSURE SWITCH
- PWM PULSE WIDTH MODULATION
- QT QUADRUPLE TERMINAL
- R THERMOSTAT POWER
- RAT RETURN AIR TEMP. SEN
- RHV REHEAT DISCHARGE VALVE
- RH RELATIVE HUMIDITY
- RLV REHEAT LIQUID VALVE
- RNET LOCAL ACCESS NETWORK
- RVS REVERSING VALVE SOLENOID
- SAT SUPPLY AIR TEMP SENSOR
- SDP SYSTEM DISCHARGE PRESSURE
- SPRH SPACE RELATIVE HUMIDITY
- SPT SPACE TEMPERATURE SENSOR
- SPTO SPACE TEMPERATURE OFFSET
- SSP SYSTEM SUCTION PRESSURE
- SW SWITCH
- TB TERMINAL BLOCK
- TDR TIME DELAY RELAY
- TRAN TRANSFORMER
- UCB UNIT CONTROL BOARD
- W1 1st STAGE OF HEATING CALL
- W2 2nd STAGE OF HEATING CALL
- Y1 1st STAGE OF COOLING CALL
- Y2 2nd STAGE OF COOLING CALL

48TC003158 -

TYPICAL 50GQM04-06 POWER WIRING DIAGRAM, 208/230V-1-60 UNIT WITH SYSTEMVU CONTROLLER SHOWN

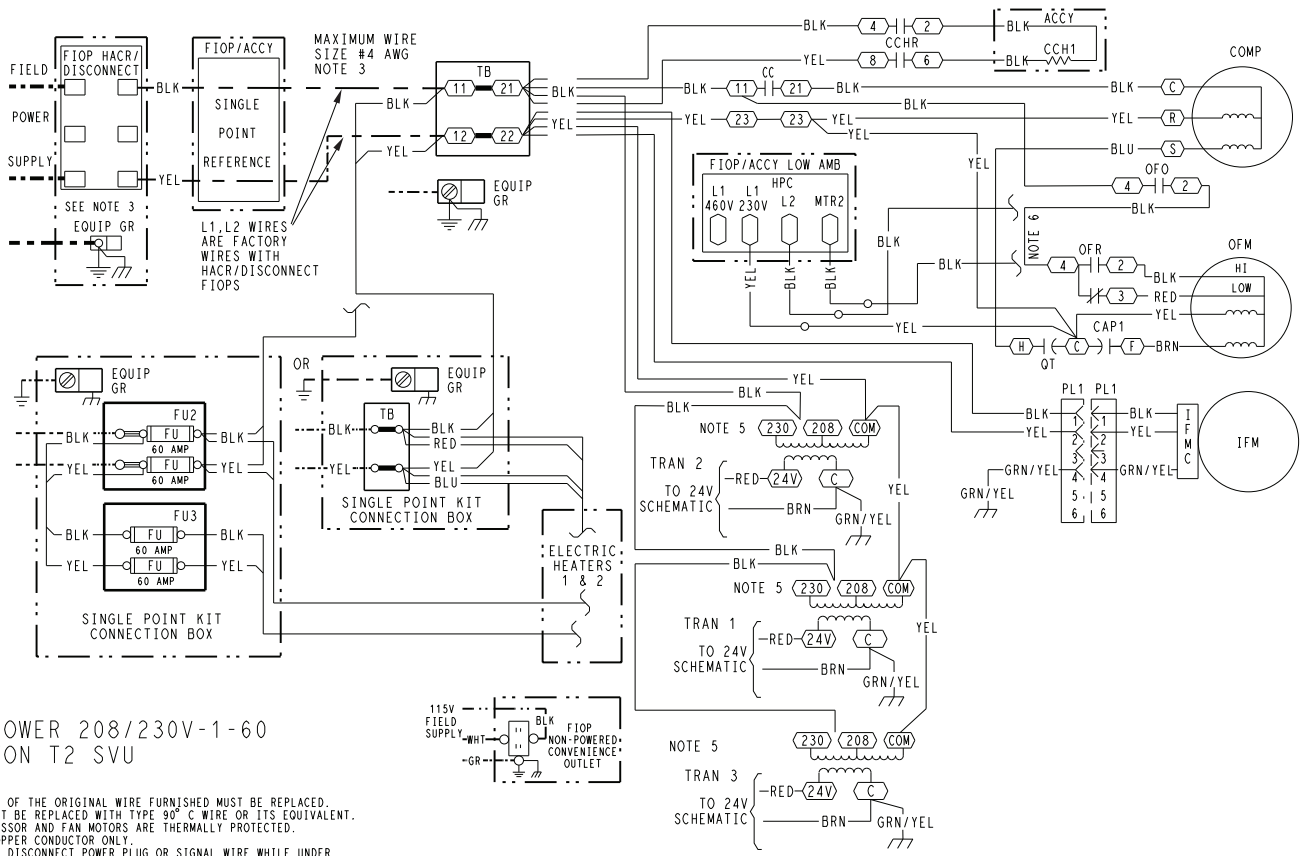

HP POWER 208/230V-1-60
3-5TON T2 SVU

- NOTES**
- IF ANY OF THE ORIGINAL WIRE FURNISHED MUST BE REPLACED, IT MUST BE REPLACED WITH TYPE 90° C WIRE OR ITS EQUIVALENT.
 - COMPRESSOR AND FAN MOTORS ARE THERMALLY PROTECTED.
 - USE COPPER CONDUCTOR ONLY.
 - DO NOT DISCONNECT POWER PLUG OR SIGNAL WIRE WHILE UNDER LOAD.
 - ON 208/230V UNITS, TRAN IS WIRED FOR 230V. IF UNIT IS TO BE RUN WITH 208V POWER SUPPLY, DISCONNECT BLK WIRE FROM 230V TAP AND CONNECT TO 208V TAP.
 - THIS WIRE NOT USED WITH LOW AMBIENT FIOP/ACCY.

LEGEND

- X MARKED WIRE
- X TERMINAL (MARKED)
- TERMINAL (UNMARKED)
- X TERMINAL BLOCK
- SPLICE
- SPLICE (MARKED)
- FACTORY WIRING
- - - - - FIELD CONTROL WIRING
- - - - - FIELD POWER WIRING
- · - · - · CIRCUIT BOARD TRACE
- · - · - · ACCESSORY OR OPTIONAL WIRING

- | | | | | | |
|--------|--|------|-----------------------------|------|---------------------------|
| ACCY | ACCESSORY | HR | HEATER RELAY | PER | POWER EXHAUST RELAY |
| AWG | AMERICAN WIRE GAGE | HGRH | HOT GAS REHEAT | PH | PHASE |
| BAS | BUILDING AUTOMATION NETWORK | HPC | HEAD PRESSURE CONTROL | PL | PLUG ASSEMBLY |
| CC | CONTACTOR, COMPRESSOR | HPS | HIGH PRESSURE SWITCH | POT | POTENTIOMETER |
| C | COMMON | HUM | HUMIDISTAT | PMR | PHASE MONITOR RELAY |
| CAP | CAPACITOR | IAO | INDOOR AIR QUALITY SENSORS | PS | PRESSURE SWITCH |
| CB | CIRCUIT BREAKER | IFM | INDOOR FAN MOTOR | PWM | PULSE WIDTH MODULATION |
| CCH | CRANKCASE HEATER | IFMC | INDOOR FAN MOTOR CONTROL | R | THERMOSTAT POWER |
| CCHR | CRANKCASE HEATER RELAY | IFO | INDOOR FAN ON SIGNAL | RAT | RETURN AIR TEMP. SEN |
| CCHTS | CRANKCASE HEATER TEMP SWITCH | IRH | INDOOR RELATIVE HUMIDITY | RDV | REHEAT DISCHARGE VALVE |
| CLO | COMPRESSOR LOCKOUT | JMP | JUMPER | RH | RELATIVE HUMIDITY |
| CLV | COOLING LIQUID VALVE | L1 | LINE 1 | RLV | REHEAT LIQUID VALVE |
| COFS | CONDENSATE OVERFLOW SWITCH | LA | LOW AMBIENT LOCKOUT | RNET | LOCAL ACCESS NETWORK |
| COM | SIGNAL COMMON | LAR | LOW AMBIENT RELAY | RVS | REVERSING VALVE SOLENOID |
| COMP | COMPRESSOR MOTOR | LAS | LOW AMBIENT SWITCH | SAT | SUPPLY AIR TEMP SENSOR |
| DDC | DIRECT DIGITAL CONTROL | LDR | COMPRESSOR LOADER | SDP | SYSTEM DISCHARGE PRESSURE |
| DFB | DEFROST BOARD | LEN | LOCAL EQUIPMENT NETWORK | SPRH | SPACE RELATIVE HUMIDITY |
| DFT | DEFROST THERMOSTAT | LOC | LOSS OF CHARGE | SPT | SPACE TEMPERATURE SENSOR |
| EHR | ELECTRIC HEAT RELAY | LPS | LOW PRESSURE SWITCH | SPT | SPACE TEMPERATURE OFFSET |
| ENTH | ENTHALPY | LS | LIMIT SWITCH | SSP | SYSTEM SUCTION OFFSET |
| ERV | ENERGY RECOVERY VENTILATOR | LSM | LIMIT SWITCH (MANUAL RESET) | SW | SWITCH |
| ESL | ENTHALPY SENSOR - LOW | LTO | LOW TEMP LOCKOUT | TB | TERMINAL BLOCK |
| FB | FUSE BLOCK | MTR | MOTOR | TDR | TIME DELAY RELAY |
| FIOP | FACTORY INSTALLED OPTION | OAO | OUTDOOR AIR QUALITY | TRAN | TRANSFORMER |
| FPT | FREEZE PROTECTION THERMOSTAT | OAT | OUTDOOR AIR TEMP. SEN | UCB | UNIT CONTROL BOARD |
| FST | FAN HOUSING TEMP SENSOR | OFM | OUTDOOR FAN MOTOR | W1 | 1st STAGE OF HEATING CALL |
| FU | FUSE | OFM | OUTDOOR FAN MOTOR | W2 | 2nd STAGE OF HEATING CALL |
| G | THERMOSTAT FAN CALL | OFR | OUTDOOR FAN ON RELAY | Y1 | 1st STAGE OF COOLING CALL |
| GR(ND) | GROUND | OL | OVERLOAD | Y2 | 2nd STAGE OF COOLING CALL |
| HACR | HEATING, AIR-CONDITIONING, REFRIGERATION BREAKER | | | | |

48TC003208 A

TYPICAL 50GQM04-06 POWER WIRING DIAGRAM, 208/230-3-60 UNIT WITH SYSTEMVU CONTROLLER SHOWN

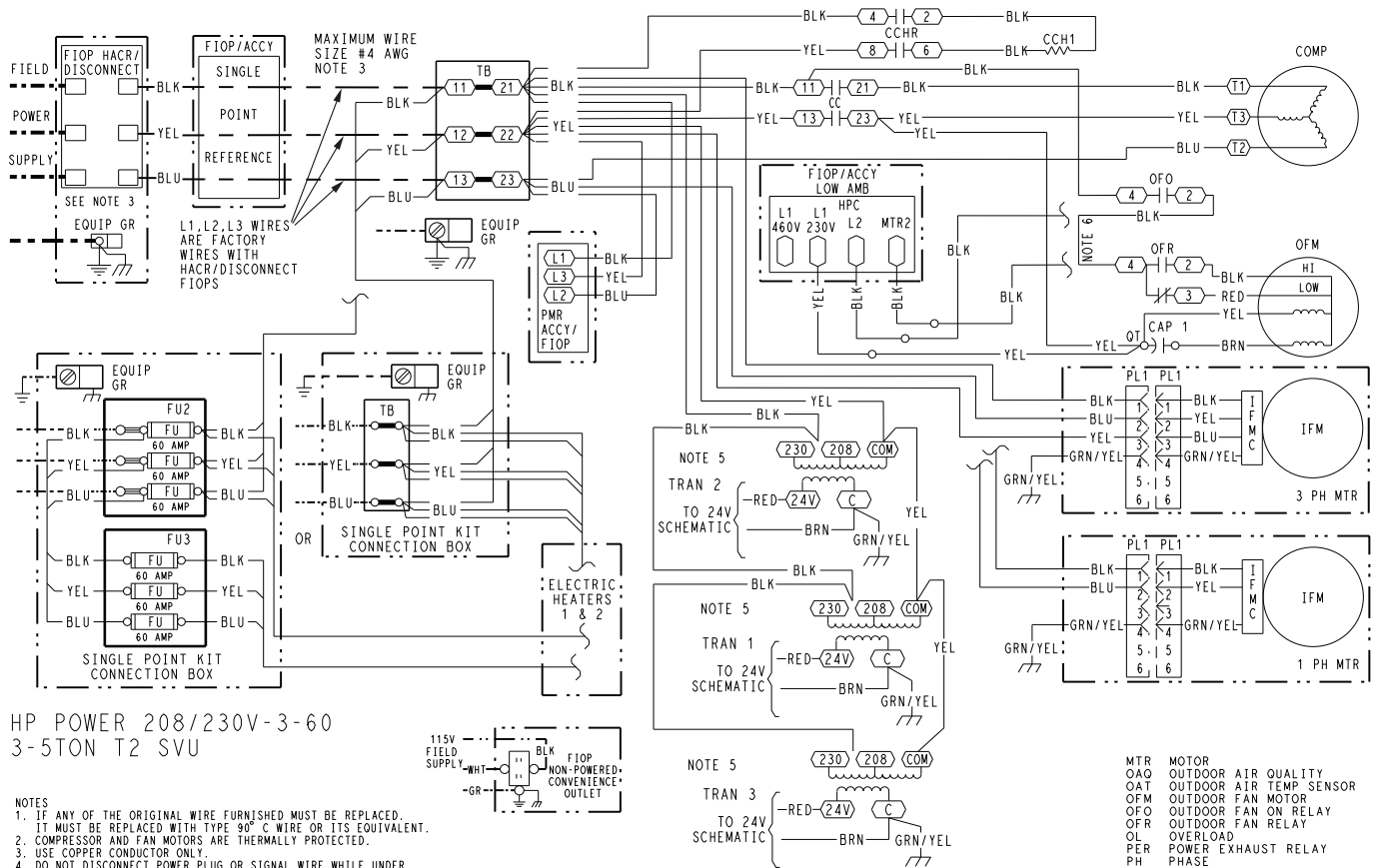

HP POWER 208/230V-3-60
3-5TON T2 SVU

- NOTES**
- IF ANY OF THE ORIGINAL WIRE FURNISHED MUST BE REPLACED. IT MUST BE REPLACED WITH TYPE 90° C WIRE OR ITS EQUIVALENT.
 - COMPRESSOR AND FAN MOTORS ARE THERMALLY PROTECTED.
 - USE COPPER CONDUCTOR ONLY.
 - DO NOT DISCONNECT POWER PLUG OR SIGNAL WIRE WHILE UNDER LOAD.
 - ON 208/230V UNITS, TRAN IS WIRED FOR 230V. IF UNIT IS TO BE RUN WITH 208V POWER SUPPLY, DISCONNECT BLK WIRE FROM 230V TAP AND CONNECT TO 208V TAP.
 - THIS WIRE NOT USED WITH LOW AMBIENT FIOP/ACCY.

LEGEND

- (X) MARKED WIRE
- (X) TERMINAL (MARKED)
- (O) TERMINAL (UNMARKED)
- (X) TERMINAL BLOCK
- SPLICE
- (●) SPLICE (MARKED)
- FACTORY WIRING
- - - FIELD CONTROL WIRING
- - - - - FIELD POWER WIRING
- - - - - CIRCUIT BOARD TRACE
- - - - - ACCESSORY OR OPTIONAL WIRING

- ACCY ACCESSORY
- AWG AMERICAN WIRE GAGE
- BAS BUILDING AUTOMATION NETWORK
- CC CONTACTOR, COMPRESSOR
- C COMMON
- CAP CAPACITOR
- CB CIRCUIT BREAKER
- CCH CRANKCASE HEATER
- CCHR CRANKCASE HEATER RELAY
- CCHTS CRANKCASE HEATER TEMP SWITCH
- CLO COMPRESSOR LOCKOUT
- CLV COOLING LIQUID VALVE
- COFS CONDENSATE OVERFLOW SWITCH
- COM SIGNAL COMMON
- COMP COMPRESSOR MOTOR
- DDC DIRECT DIGITAL CONTROL
- DFB DEFROST BOARD
- DFT DEFROST THERMOSTAT
- EHR ELECTRIC HEAT RELAY
- ENTH ENTHALPY
- ERV ENERGY RECOVERY VENTILATOR
- ESL ENTHALPY SENSOR - LOW
- FB FUSE BLOCK
- FIOF FACTORY INSTALLED OPTION
- FPT FREEZE PROTECTION THERMOSTAT
- FST FAN HOUSING TEMP SENSOR
- FU FUSE

- G THERMOSTAT FAN CALL
- GR(GND) GROUND
- HACR HEATING, AIR-CONDITIONING, REFRIGERATION BREAKER
- HR HEATER RELAY
- HGRH HOT GAS REHEAT
- HPC HEAD PRESSURE CONTROL
- HPS HIGH PRESSURE SWITCH
- HUM HUMIDISTAT
- IAO INDOOR AIR QUALITY SENSORS
- IFM INDOOR FAN MOTOR
- IFMC INDOOR FAN MOTOR CONTROL
- IFO INDOOR FAN ON SIGNAL
- IRH INDOOR RELATIVE HUMIDITY
- JMP JUMPER
- L1 LINE 1
- LA LOW AMBIENT LOCKOUT
- LAR LOW AMBIENT RELAY
- LAS LOW AMBIENT SWITCH
- LDR COMPRESSOR LOADER
- LEN LOCAL EQUIPMENT NETWORK
- LOC LOSS OF CHARGE
- LPS LOW PRESSURE SWITCH
- LS LIMIT SWITCH
- LSM LIMIT SWITCH (MANUAL RESET)
- LTL0 LOW TEMP LOCKOUT

- MTR MOTOR
- OAQ OUTDOOR AIR QUALITY
- OAT OUTDOOR AIR TEMP SENSOR
- OFM OUTDOOR FAN MOTOR
- OFO OUTDOOR FAN ON RELAY
- OFR OUTDOOR FAN RELAY
- OL OVERLOAD
- PER POWER EXHAUST RELAY
- PH PHASE
- PL PLUG ASSEMBLY
- POT POTENTIOMETER
- PMR PHASE MONITOR RELAY
- PS PRESSURE SWITCH
- PWM PULSE WIDTH MODULATION
- QAT QUADRUPE TERMINAL
- R THERMOSTAT POWER
- RAT RETURN AIR TEMP SENSOR
- RDV REHEAT DISCHARGE VALVE
- RH RELATIVE HUMIDITY
- RLV REHEAT LIQUID VALVE
- RNET LOCAL ACCESS NETWORK
- RVS REVERSING VALVE SOLENOID
- SAT SUPPLY AIR TEMP SENSOR
- SDP SYSTEM DISCHARGE PRESSURE
- SPRH SPACE RELATIVE HUMIDITY
- SPT SPACE TEMPERATURE SENSOR
- SPTO SPACE TEMPERATURE OFFSET
- SSP SYSTEM SUCTION PRESSURE
- SW SWITCH
- TB TERMINAL BLOCK
- TDR TIME DELAY RELAY
- TRAN TRANSFORMER
- UCB UNIT CONTROL BOARD
- W1 1st STAGE OF HEATING CALL
- W2 2nd STAGE OF HEATING CALL
- Y1 1st STAGE OF COOLING CALL
- Y2 2nd STAGE OF COOLING CALL

48TC003209 A

TYPICAL 50GCQM04-06 POWER WIRING DIAGRAM, 460/575-3-60 UNIT WITH SYSTEMVU CONTROLLER SHOWN

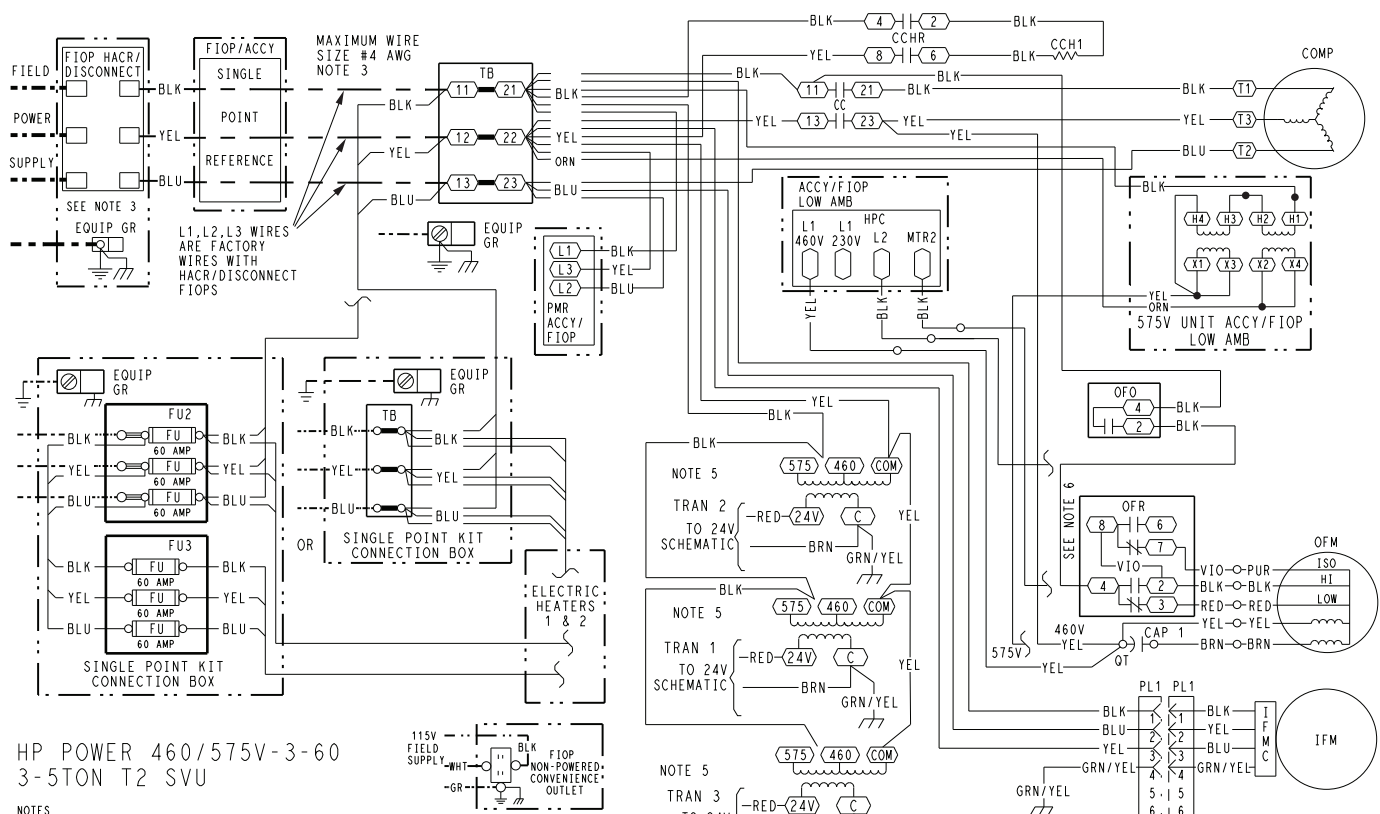

HP POWER 460/575V-3-60
3-5TON T2 SVU

- NOTES**
- IF ANY OF THE ORIGINAL WIRE FURNISHED MUST BE REPLACED, IT MUST BE REPLACED WITH TYPE 90° C WIRE OR ITS EQUIVALENT.
 - COMPRESSOR AND FAN MOTORS ARE THERMALLY PROTECTED.
 - USE COPPER CONDUCTOR ONLY.
 - DO NOT DISCONNECT POWER PLUG OR SIGNAL WIRE WHILE UNDER LOAD.
 - TRANSFORMER IS DEDICATED BASED ON UNIT VOLTAGE. TAPS ONLY SHOWN TO SIMPLIFY SCHEMATIC.
 - THIS WIRE NOT USED WITH LOW AMBIENT FIOP/ACCY.

LEGEND

- X MARKED WIRE
- TERMINAL (MARKED)
- TERMINAL (UNMARKED)
- X TERMINAL BLOCK
- SPLICE
- SPLICE (MARKED)
- FACTORY WIRING
- - - FIELD CONTROL WIRING
- - - - - FIELD POWER WIRING
- - - - - CIRCUIT BOARD TRACE
- - - - - ACCESSORY OR OPTIONAL WIRING

- ACCY ACCESSORY WIRE GAGE
- AWG AMERICAN WIRE GAGE
- BAS BUILDING AUTOMATION NETWORK
- CC CONTACTOR, COMPRESSOR COMMON
- CAP CAPACITOR
- CB CIRCUIT BREAKER
- CCH CRANKCASE HEATER
- CCHR CRANKCASE HEATER RELAY
- CCHTS CRANKCASE HEATER TEMP SWITCH
- CLO COMPRESSOR LOCKOUT
- CLV COOLING LIQUID VALVE
- COFS CONDENSATE OVERFLOW SWITCH
- COM SIGNAL COMMON
- COMP COMPRESSOR MOTOR
- DDC DIRECT DIGITAL CONTROL
- DFB DEFROST BOARD
- DFT DEFROST THERMOSTAT
- EHR ELECTRIC HEAT RELAY
- ENTH ENTHALPY
- ERV ENERGY RECOVERY VENTILATOR
- ESL ENTHALPY SENSOR - LOW
- FB FUSE BLOCK
- FIOP FACTORY INSTALLED OPTION
- FPT FREEZE PROTECTION THERMOSTAT
- FST FAN HOUSING TEMP SENSOR
- FU FUSE
- G THERMOSTAT FAN CALL
- GR(GND) GROUND

- HACR HEATING, AIR-CONDITIONING, REFRIGERATION BREAKER
- HR HEATER RELAY
- HGRH HOT GAS REHEAT
- HPC HEAD PRESSURE SWITCH
- HPS HIGH PRESSURE SWITCH
- HUM HUMIDISTAT
- IAQ INDOOR AIR QUALITY SENSORS
- IAO INDOOR AIR QUALITY SENSORS
- IFM INDOOR FAN MOTOR CONTROL
- IFO INDOOR FAN ON SIGNAL
- IRH INDOOR RELATIVE HUMIDITY
- JMP JUMPER
- L1 LINE 1
- LA LOW AMBIENT LOCKOUT
- LAR LOW AMBIENT RELAY
- LAS LOW AMBIENT SWITCH
- LDR COMPRESSOR LOADER
- LEN LOCAL EQUIPMENT NETWORK
- LOC LOSS OF CHARGE
- LPS LOW PRESSURE SWITCH
- LS LIMIT SWITCH
- LSM LIMIT SWITCH (MANUAL RESET)
- LTLO LOW TEMP LOCKOUT
- MTR MOTOR
- OAO OUTDOOR AIR QUALITY
- OAT OUTDOOR AIR TEMP. SEN
- OFM OUTDOOR FAN MOTOR
- OFR OUTDOOR FAN RELAY
- OFO OUTDOOR FAN ON RELAY
- OL OVERLOAD

- PER POWER EXHAUST RELAY
- PH PHASE
- PL PHASE ASSEMBLY
- POT POTENTIOMETER
- PMR PHASE MONITOR RELAY
- PS PRESSURE SWITCH
- PWM PULSE WIDTH MODULATION
- QT QUADRUPLE TERMINAL
- R THERMOSTAT POWER
- RAT RETURN AIR TEMP. SEN
- RDV REHEAT DISCHARGE VALVE
- RH RELATIVE HUMIDITY
- RLV REHEAT LIQUID VALVE
- RNET LOCAL ACCESS NETWORK
- RVS REVERSING VALVE SOLENOID
- SAT SUPPLY AIR TEMP SENSOR
- SDP SYSTEM DISCHARGE PRESSURE
- SPRH SPACE RELATIVE HUMIDITY
- SPT SPACE TEMPERATURE SENSOR
- SPTO SPACE TEMPERATURE OFFSET
- SSP SYSTEM SUCTION PRESSURE
- SW SWITCH
- TB TERMINAL BLOCK
- TDR TIME DELAY RELAY
- TRAN TRANSFORMER
- UCB UNIT CONTROL BOARD
- W1 1st STAGE OF HEATING CALL
- W2 2nd STAGE OF HEATING CALL
- Y1 1st STAGE OF COOLING CALL
- Y2 2nd STAGE OF COOLING CALL

48TC003210 A

General

The sequence below describes the sequence of operation for an electro-mechanical unit with and without a factory-installed EconoMi\$er® IV (W7212 controller) and X (called “economizer” in this sequence) (W7220 controller). For information regarding a direct digital controller, see the start-up, operations, and troubleshooting manual for the applicable controller.

Electro-Mechanical Units with No Economizer

Cooling (two stage units)

When the thermostat calls for cooling, terminals G and Y1 are energized. The indoor fan will run at the low fan speed and the compressor contactor (CC) is energized causing the compressor and outdoor fan to turn on. The low indoor fan speed is 75% of the user set fan speed, the compressor will run at partial capacity, and the outdoor fan will run at low speed.

If additional cooling is needed, the thermostat will add the call for Y2. This will increase the indoor fan speed to the user set fan speed, energize the compressor loader for full compressor capacity, and energize the outdoor fan relay (OFR) for high speed.

When the thermostat removes the call for Y2 but leaves the Y1, the indoor fan will reduce speed to 75% of the user set fan speed, the compressor loader will turn off, and the outdoor fan will drop to low speed. When the thermostat removes the call for Y1 the compressor contactor will de-energize, shutting down the compressor and the outdoor fan. When the thermostat removes the call for G, the indoor fan will turn off after the specific unit fan off delay.

Heating, unit with economizer

When the room temperature calls for heat through terminal W1, the indoor (evaporator) fan contactor (IFC) and heater contactor no. 1 (HC1) are energized and the reversing valve(s) de-energize and switches position.

On units equipped for 2 stages of heat, when additional heat is needed, heater contactor no. 2 is energized through W2. The economizer damper moves to the minimum position.

When the thermostat is satisfied, the damper moves to the fully closed position.

Heating, unit without economizer

Upon a request for heating from the space thermostat, terminal W1 will be energized with 24V. The IFC, outdoor fan contactor (OFC), C1, and C2 will be energized. The indoor fan, outdoor fans, and compressor no. 1, and compressor no. 2 are energized and reversing valves are de-energized and switch position.

If the space temperature continues to fall while W1 is energized, W2 will be energized with 24V, and the heater contactor(s) (HC) will be energized, which will energize the electric heater(s).

When the space thermostat is satisfied, W2 will be de-energized first, and the electric heater(s) will be de-energized. Upon a further rise in space temperature, W1 will be de-energized.

Electric Heating

NOTE: Base 50GCQ units are cooling and heat pump heating only. If supplement electric heaters are required, use only factory-approved heaters listed and offered by Carrier.

Units have either 1 or 2 stages of electric heat. When the thermostat calls for heating, power is applied to G and the W1 terminals at the unit. The unit control will energize the indoor fan contactor and the first stage of electric heat. On units with two-stage heating, when additional heating is required, the second stage of electric heat (if equipped) will be energized when power is applied at the W2 terminal on the unit.

IMPORTANT: The thermostat must be configured for Electric Heat so it will energize G with the W1 call.

Electro-mechanical Units with Economizer

Cooling

NOTE: EconoMi\$er IV is only available as a field-installed accessory for 50GCQ units. EconoMi\$er X is available as both a factory-installed option or a field-installed accessory.

When free cooling is not available, the compressors will be controlled by the zone thermostat. When free cooling is available, the outdoor-air damper is modulated by the EconoMi\$er IV and X control to provide a 50°F (10°C) to 55°F (13°C) mixed-air temperature into the zone. As the mixed air temperature fluctuates above 55°F (13°C) or below 50°F (10°C) dampers will be modulated (open or close) to bring the mixed-air temperature back within control. If mechanical cooling is utilized with free cooling, the outdoor-air damper will maintain its current position at the time the compressor is started. If the increase in cooling capacity causes the mixed-air temperature to drop below 45°F (7°C), then the outdoor-air damper position will be decreased to the minimum position. If the mixed-air temperature continues to fall, the outdoor-air damper will close. Control returns to normal once the mixed-air temperature rises above 48°F (9°C). The power exhaust fans will be energized and de-energized, if installed, as the outdoor-air damper opens and closes.

If field-installed accessory CO₂ sensors are connected to the EconoMi\$er IV and X control, a demand controlled ventilation strategy will begin to operate. As the CO₂ level in the zone increases above the CO₂ set-point, the minimum position of the damper will be increased proportionally. As the CO₂ level decreases because of the increase in fresh air, the outdoor-air damper will be proportionally closed. For EconoMi\$er IV and X operation, there must be a thermostat call for the fan (G). If the unit is occupied and the fan is on, the damper will operate at minimum position. Otherwise, the damper will be closed.

When the EconoMi\$er IV and X control is in the occupied mode and a call for cooling exists (Y1 on the thermostat), the control will first check for indoor fan operation. If the fan is not on, then cooling will not be activated. If the fan is on, then the control will open the EconoMi\$er IV and X damper to the minimum position.

On the initial power to the EconoMi\$er IV and X control, it will take the damper up to 2¹/₂ minutes before it begins to position itself. After the initial power-up, further changes in damper position can take up to 30 seconds to initiate. Damper movement from full closed to full open (or vice versa) will take between 1¹/₂ and 2¹/₂ minutes. If free cooling can be used as determined from the appropriate changeover command (switch, dry bulb, enthalpy curve, differential dry bulb, or differential enthalpy), then the control will modulate the dampers open to maintain the mixed-air temperature set-point at 50°F (10°C) to 55°F (13°C). If there is a further demand for cooling (cooling second stage — Y2 is energized),

then the control will bring on compressor stage 1 to maintain the mixed-air temperature set-point. The EconoMi\$er® IV and X damper will be open at maximum position.

2-Speed Note: When operating in ventilation mode only, the indoor fan motor will automatically adjust to 75% of the total cfm established.

Defrost

When the temperature of the outdoor coil drops below 28°F (-2°C) as sensed by the defrost thermostat (DFT2) and the defrost timer is at the end of a timed period (adjustable at 30, 60, 90 or 120 minutes), reversing valve solenoids (RVS1 and RVS2) are energized and the OFC is de-energized. This switches the position of the reversing

valves and shuts off the outdoor fan. The electric heaters (if installed) will be energized.

RTU Open controller (factory option)

For details on operating 50GCQ units equipped with the factory-installed RTU Open controller option, refer to Factory Installed RTU Open Multi-Protocol Controller Controls, Start-Up, Operation and Troubleshooting manual.

SystemVu™ controller (factory option)

For details on operating 50GCQ units equipped with the factory-installed SystemVu controller option, refer to FCQ/GCQ Series Single Package Rooftop Units with SystemVu Controller Controls, Start-Up, Operation and Troubleshooting manual.

Minimum operating ambient temperature (cooling)

In mechanical cooling mode, your Carrier rooftop unit can safely operate down to an outdoor ambient temperature of 35°F (2°C). It is possible to provide cooling at lower outdoor ambient temperatures by using less outside air, economizers, and/or accessory low ambient kits.

Maximum operating ambient temperature (cooling)

The maximum operating ambient temperature for cooling mode is 125°F (52°C) at nominal voltage rating. While cooling operation above 125°F (52°C) may be possible, it could cause either a reduction in performance, reliability, or a protective action by the unit's internal safety devices.

Multiple motor and drive packages

Some applications need larger horsepower motors, some need more airflow, and some need both. Regardless of the case, your Carrier expert has a factory installed combination to meet your application. A wide selection of motors and pulleys (drives) are available, factory installed, to handle nearly any application.

Minimum and maximum airflow (heating and cooling)

To maintain safe and reliable operation of your rooftop, operate within the heating airflow limits during heating mode and cooling airflow limits during cooling mode. Operating above the max may cause blow-off, undesired airflow noise, or airflow related problems with the rooftop unit. Operating below the min may cause problems with coil freeze-up and unsafe heating operation. Heating and cooling limitations differ when evaluating operating CFM, the minimum value is the HIGHER of the cooling and heating minimum CFM values published on page 5 and the maximum value is the LOWER of the cooling and heating minimum values published on page 5.

Heating-to-cooling changeover

Your unit will automatically change from heating to cooling mode when using a thermostat with an auto-changeover feature.

Airflow

All units are draw-through in cooling mode and blow-through in heating mode.

Outdoor air application strategies

Economizers reduce operating expenses and compressor run time by providing a free source of cooling and a means of ventilation to match application changing needs. In fact, they should be considered for most applications. Also,

consider the various economizer control methods and their benefits, as well as sensors required to accomplish your application goals. Please contact your local Carrier representative for assistance.

Motor limits, break horsepower (BHP)

Due to internal design of Carrier units, the air path, and specially designed motors, the full horsepower (maximum continuous BHP) band, as listed in the Fan Performance tables, can be used with the utmost confidence. There is no need for extra safety factors, as Carrier motors are designed and rigorously tested to use the entire, listed BHP range without either nuisance tripping or premature motor failure.

Sizing a rooftop

Bigger is not necessarily better. While an air conditioner needs to have enough capacity to meet the design loads, it does not need excess capacity. In fact, excess capacity typically results in very poor part load performance and humidity control.

Using higher design temperatures than ASHRAE recommends for your location, adding "safety factors" to the calculated load, are all signs of oversizing air conditioners. Oversizing the air conditioner leads to poor humidity control, reduced efficiency, higher utility bills, larger indoor temperature swings, excessive noise, and increased wear and tear on the air conditioner.

Rather than oversizing an air conditioner, engineers should "right-size" or even slightly "under-size" air conditioners. Correctly sizing an air conditioner controls humidity better; promotes efficiency; reduces utility bills; extends equipment life, and maintains even, comfortable temperatures. Please contact your local Carrier representative for assistance.

Low ambient applications

The optional Carrier economizer can adequately cool your space by bringing in fresh, cool outside air. In fact, when so equipped, accessory low-ambient kit may not be necessary. In low ambient conditions, unless the outdoor air is excessively humid or contaminated, economizer-based "free cooling" is the preferred less costly and energy conscious method. In low ambient applications where outside air might not be desired (such as contaminated or excessively humid outdoor environments), your Carrier rooftop can operate to ambient temperatures down to -20°F (-29°C) using the recommended accessory low ambient controller.

Two stage cooling operation

Use appropriate two stage thermostat to achieve the unit's optimum design comfort and overall operating performance.

Note about this specification:

This specification is in the “Masterformat” as published by the Construction Specification Institute. Please feel free to copy this specification directly into your building spec.



High Efficiency Rooftop Packaged Heat Pump HVAC Guide Specifications

Size Range: **3 to 5 Nominal Tons**

Carrier Model Number: **50GCQM04-06**

Part 1 — (23 06 80) Schedules for Decentralized HVAC Equipment

1.01 (23 06 80.13) Decentralized Unitary HVAC Equipment Schedule:

- A. (23 06 80.13.A.) Rooftop unit (RTU) schedule:
 - 1. Schedule is per the project specification requirements.

Part 2 — (23 07 16) HVAC equipment insulation

2.01 (23 07 16.13) Decentralized, Rooftop Units:

- A. (23 07 16.13.A.) Evaporator fan compartment:
 - 1. Interior cabinet surfaces shall be insulated with a minimum 1/2-in. thick, minimum 1 1/2 lb density, flexible fiberglass insulation bonded with a phenolic binder, neoprene coated on the air side.
 - 2. Insulation and adhesive shall meet NFPA 90A requirements for flame spread and smoke generation.
- B. (23 07 16.13.B.) Electric Heat Compartment:
 - 1. Aluminum foil-faced fiberglass insulation shall be used.
 - 2. Insulation and adhesive shall meet NFPA 90A requirements for flame spread and smoke generation.

Part 3 — (23 09 13) Instrumentation and control devices for HVAC

3.01 (23 09 13.13) Sensors and Transmitters:

- A. (23 09 13.13.A.) Thermostats:
 - 1. Thermostat must
 - a. have capability to energize 2 stages of cooling, and 2 different stages of heating. All models have 2-stage cooling capabilities.
 - b. be heat pump design and include capability for occupancy scheduling.

Part 4 — (23 09 23) Direct Digital Control system for HVAC

4.01 (23 09 23.13) Decentralized, Rooftop Units:

- A. (23 09 23.13.A.) SystemVu™ intelligent integrated Direct Digital Control (DDC) shall provide:
 - 1. Integrated unit operation for comfort cooling, heating ventilation as well as all monitoring, recording and reporting capabilities. Controller

shall also provide diagnostics and alarms of abnormal unit operation through the controller. Controller shall have an intuitive user display and be able to be used in a standalone operation or via building automation system (BAS).

- 2. Quick Unit Status LEDs of: Run – meaning all systems are go, ALERT – that indicates there is currently a non-critical issue with the unit, like filters need to be replaced and FAULT – that indicates the unit has a critical issue and will possibly shut down.
- 3. Six large navigation keys for easy access. Navigation keys shall consist of: TEST, BACK, ENTER, and MENU along with UP and DOWN arrows.
- 4. Full back lit user display with 4 line by 30 character text capabilities. Display menu shall be designed to provide guided major menus and sub menus main menus provided below:
 - a. Shutdown Unit
 - b. Run Status
 - c. Settings
 - d. Alerts/Faults
 - e. Service
 - f. Inputs
 - g. Outputs
 - h. USB
- 5. The capability for standalone operation with conventional thermostat/sensor or use with building automation systems (BAS) of Carrier i-Vu®, BACnet and Carrier Comfort Network® (CCN) systems. No special modules or boards are required for these capabilities. Has the capability to work with Equipment Touch™ and System Touch™ devices and ZS Sensors.
- 6. The ability to read refrigerant pressures at display or via BAS network of; Discharge Pressure and Suction Pressure. The need for traditional refrigerant gages is not required.
- 7. USB Data Port for flash drive interaction. This will allow the transfer of data for uploads, downloads, perform software upgrades, back-up and restore data and file transfer data such as component number of starts and run hours.
- 8. Reverse Rotation Protection of compressors if field three phase wiring is misapplied.
- 9. Provide Service Capabilities of:
 - a. Auto run test
 - b. Manual run test
 - c. Component run hours and starts
 - d. Commissioning reports
 - e. Data logging
 - f. Alarm history

10. Economizer control and diagnostics. Set up economizer operation, receive feedback from actuator. Also meets the most recent California Title 24, ASHRAE 90.1 and IECC Fault Detection and Diagnostic (FDD) requirements.
 11. Unit cooling operation down to 35°F (2°C).
 12. Controller shall have easy access connections around the controller perimeter area and consist of Mate-N-Lok¹, terminal block and RJ style modular jack connections.
 13. 365 day real time clock, 20 holiday schedules along with occupied and unoccupied scheduling.
 14. Auto-Recognition for easy installation and commissioning of devices like economizers, space sensors, etc.
 15. A 5°F temperature difference between cooling and heating set points to meet the latest ASHRAE 90.1 Energy Standard.
 16. Contain return air sensor, supply air sensor and outdoor air sensor to help monitor and provide data for the unit comfort operation, diagnostic and alarms.
 17. Use of Carrier's field accessory hand-held Navigator™ display, Equipment Touch and System Touch devices.
 18. Supply Air Tempering control operates the electric heat to maintain a minimum supply air temperature during conditions where very cold outdoor air causes the supply air temperature to fall below the configured Supply Air Tempering Setpoint. This occurs during periods where DCV is active and increasing the amount of outdoor air or in cases where the system is operating at very low airflow and the calculated economizer position has increased to maintain a constant ventilation rate.
 19. Demand limiting in SystemVu™ is achieved through set point expansion. The systems heating and cooling set points are expanded in steps or levels. The degree to which the set points may be expanded is defined by the 6 demand level offsets and the 2 commanded demand limit levels.
 20. 3-year limited part warranty.
- B. (23 09 23.13.B.) RTU Open Protocol, Direct Digital Controller:
1. Shall be ASHRAE 62 compliant.
 2. Shall accept 18 - 30VAC, 50 - 60Hz, and consumer 15VA or less power.
3. Shall have an operating temperature range from -40°F (-40°C) to 130°F (54°C), 10% to 90% RH (non-condensing).
 4. Shall include built-in protocol for BACnet² (MS/TP and PTP modes), Modbus³ (RTU and ASCII), Johnson N2 and LonWorks⁴. LonWorks Echelon processor required for all Lon applications shall be contained in separate communication board.
 5. Shall allow access of up to 62 network variables (SNVT). Shall be compatible with all open controllers.
 6. Baud rate controller shall be selectable using a dipswitch.
 7. Shall have an LED display independently showing the status of serial communication, running, errors, power, all digital outputs, and all analog inputs.
 8. Shall accept the following inputs: space temperature, setpoint adjustment, outdoor air temperature, indoor air quality, outdoor air quality, compressor lock-out, fire shutdown, enthalpy switch, and fan status/filter status/humidity/remote occupancy.
 9. Shall provide the following outputs: economizer, fan, cooling stage 1, cooling stage 2, heat stage 1, heat stage 2, exhaust, reversing valve/high fan speed.
 10. Shall have built-in surge protection circuitry through solid-state polyswitches. Polyswitches shall be used on incoming power and network connections. Polyswitches will return to normal when the "trip" condition clears.
 11. Shall have a battery back-up capable of a minimum of 10,000 hours of data and time clock retention during power outages.
 12. Shall have built-in support for Carrier technician tool.
 13. Shall include an RS-485 protocol communication port, an access port for connection of either a computer or a Carrier technician tool, an RS-485 port for network communication to intelligent space sensors and displays, and a port to connect an optional LonWorks communications card.
 14. Software upgrades will be accomplished by either local or remote download. No software upgrades through chip replacements are allowed.

1. Mate-N-Lok is a registered trademark of the Whitaker Corporation.

2. BACnet is a registered trademark of ASHRAE (American Society of Heating, Refrigerating and Air-Conditioning Engineers).
3. Modbus is a registered trademark of Schneider Electric.
4. LonWorks is a registered trademark of Echelon Corporation.

Part 5 — (23 09 33) Electric and Electronic Control System for HVAC

5.01 (23 09 33.13) Decentralized, Rooftop Units:

A. (23 09 33.13.A.) General:

1. Shall be complete with self-contained low-voltage control circuit protected by a resettable circuit breaker on the 24-v transformer side. Transformer shall have 75VA capability. Two per unit.
2. Shall utilize color-coded wiring.
3. Shall include a Unit Control Board to conveniently and safely provide connection points for vital control functions such as: smoke detectors, phase monitor, economizer, thermostat, DDC control options, and low and high pressure switches. Controller shall also provide an intuitive means to adjust the indoor fan speed through a simple switch and pot adjustment design.
4. Unit shall include a minimum of one 8-pin screw terminal connection board for connection of control wiring.
5. Shall include integrated defrost system to prevent excessive frost accumulation during heating duty, and shall be controlled as follows:
 - a. Defrost shall be initiated on the basis of time and coil temperature.
 - b. A 30,60,90,120 minute timer shall activate the defrost cycle only if the coil temperature is low enough to indicate a heavy frost condition.
 - c. Defrost cycle shall terminate when defrost thermostat is satisfied and shall have a positive termination time of 10 minutes.
6. Defrost system shall also include:
 - a. Defrost Cycle Indicator LED.
 - b. Dip switch selectable defrost time between 30, 60, 90 and 120 minutes. Factory set at 30 minutes.
 - c. Molded plug connection to ensure proper connection.

B. (23 09 33.13.B.) Safeties:

1. Compressor over-temperature, over-current. High internal pressure differential.
2. Low pressure switch.
 - a. Low pressure switch shall use different color wire than the high pressure switch. The purpose is to assist the installer and service technician to correctly wire and or troubleshoot the rooftop unit.
3. High pressure switch.
 - a. High pressure switch shall use different color wire than the low pressure switch. The purpose is to assist the installer and service technician to correctly wire and or troubleshoot the rooftop unit.

4. Automatic reset, motor thermal overload protector.

Part 6 — (23 09 93) Sequence of Operations for HVAC Controls

6.01 (23 09 93.13) Decentralized, Rooftop Units:

- #### A. (23 09 93.13.A.) INSERT SEQUENCE OF OPERATION

Part 7 — (23 40 13) Panel Air Filters

7.01 (23 40 13.13) Decentralized, Rooftop Units:

A. (23 40 13.13.A.) Standard filter section:

1. Shall consist of factory installed, low velocity, disposable 2-in. thick fiberglass filters of commercially available sizes.
2. Unit shall use only one filter size. Multiple sizes are not acceptable.
3. Filters shall be accessible through an access panel with “no-tool” removal as described in the unit cabinet section of this specification (23 81 19.13.G).

Part 8 — (23 81 19) Self-Contained Air Conditioners

8.01 (23 81 19.13) Small-Capacity Self-Contained Air Conditioners (50GCQ 04-06):

A. (23 81 19.13.A.) General:

1. Outdoor, rooftop mounted, electrically controlled, heating and cooling unit utilizing a fully hermetic scroll compressor(s) for cooling duty and optional electric heat for heating duty.
2. Factory assembled, single-piece heating and cooling rooftop unit. Contained within the unit enclosure shall be all factory wiring, piping, controls, and special features required prior to field start-up.
3. Unit shall use Puron[®] (R-410A) refrigerant.
4. Unit shall be installed in accordance with the manufacturer’s instructions.
5. Unit must be selected and installed in compliance with local, state, and federal codes.

B. (23 81 19.13.B.) Quality Assurance:

1. Unit meets and exceeds ASHRAE 90.1 minimum efficiency requirements.
2. Unit shall be rated in accordance with AHRI Standards 210/240.
3. Unit shall be designed to conform to ASHRAE 15.
4. Unit shall be UL-tested and certified in accordance with ANSI Z21.47 Standards and UL-listed and certified under Canadian standards as a total package for safety requirements.
5. Insulation and adhesive shall meet NFPA 90A requirements for flame spread and smoke generation.
6. Unit casing shall be capable of withstanding 500 hour salt spray exposure per ASTM B117 (scribed specimen).

7. Unit shall be designed in accordance with ISO 9001, and shall be manufactured in a facility registered by ISO 9001:2015.
 8. Roof curb shall be designed to conform to NRCA Standards.
 9. Unit shall be subjected to a completely automated run test on the assembly line. The data for each unit will be stored at the factory, and must be available upon request.
 10. Unit shall be designed in accordance with UL Standard 1995, including tested to withstand rain.
 11. Unit shall be constructed to prevent intrusion of snow and tested to prevent snow intrusion into the control box up to 40 mph.
 12. Unit shake tested to assurance level 1, ASTM D4169 to ensure shipping reliability.
- C. (23 81 19.13.C.) Delivery, Storage, and Handling:
1. Unit shall be stored and handled per manufacturer's recommendations.
 2. Lifted by crane requires either shipping top panel or spreader bars.
 3. Unit shall only be stored or positioned in the upright position.
- D. (23 81 19.13.D.) Project Conditions:
1. As specified in the contract.
- E. (23 81 19.13.E.) Operating Characteristics:
1. Unit shall be capable of starting and running at 125°F (52°C) ambient outdoor temperature, meeting maximum load criteria of AHRI Standard 210/240 at ±10% voltage.
 2. Compressor with standard controls shall be capable of operation down to 35°F (2°C), ambient outdoor temperatures. Accessory winter start kit is necessary if mechanically cooling at ambient temperatures down to 25°F (-4°C).
 3. Unit shall discharge supply air vertically or horizontally as shown on contract drawings.
 4. Unit shall be factory configured for vertical supply and return configurations.
 5. Unit shall be field convertible from vertical to horizontal airflow on all models. No special kit required.
 6. Unit shall be capable of mixed operation: vertical supply with horizontal return or horizontal supply with vertical return.
- F. (23 81 19.13.F.) Electrical Requirements:
1. Main power supply voltage, phase, and frequency must match those required by the manufacturer.
- G. (23 81 19.13.G.) Unit Cabinet:
1. Unit cabinet shall be constructed of galvanized steel, and shall be bonderized and coated with a pre-painted baked enamel finish on all externally exposed surfaces.
2. Unit cabinet exterior paint shall be: film thickness, (dry) 0.003-in. minimum, gloss (per ASTM D523, 60°F/16°C): 60, Hardness: H-2H Pencil hardness.
 3. Evaporator fan compartment interior cabinet insulation shall conform to AHRI Standards 210/240 minimum exterior sweat criteria. Interior surfaces shall be insulated with a minimum 1/2-in. thick, 1 lb density, flexible fiberglass insulation, neoprene coated on the air side. Aluminum foil-faced fiberglass insulation shall be used in the heat compartment.
 4. Base of unit shall have a minimum of four locations for thru-the-base gas and electrical connections (factory-installed or field-installed), standard.
 5. Base Rail:
 - a. Unit shall have base rails on a minimum of 2 sides.
 - b. Holes shall be provided in the base rails for rigging shackles to facilitate maneuvering and overhead rigging.
 - c. Holes shall be provided in the base rail for moving the rooftop by fork truck.
 - d. Base rail shall be a minimum of 16 gage thickness.
 6. Condensate pan and connections:
 - a. Shall be a sloped condensate drain pan made of a corrosion resistant material.
 - b. Shall comply with ASHRAE Standard 62.
 - c. Shall use a 3/4-in. 14 NPT drain connection, possible either through the bottom or side of the drain pan. Connection shall be made per manufacturer's recommendations.
 7. Top panel:
 - a. Shall be a single piece top panel on all sizes.
 8. Electrical Connections:
 - a. All unit power wiring shall enter unit cabinet at a single, factory prepared, knockout location.
 - b. Thru-the-base capability:
 - 1) Standard unit shall have a thru-the-base electrical location(s) using a raised, embossed portion of the unit basepan.
 - 2) Optional, factory approved, water-tight connection method must be used for thru-the-base electrical connections.
 - 3) No basepan penetration, other than those authorized by the manufacturer, is permitted.
 9. Component access panels (standard):
 - a. Cabinet panels shall be easily removable for servicing.
 - b. Unit shall have one factory installed, tool-less, removable, filter access panel.

- c. Panels covering control box, indoor fan, indoor fan motor, gas components (where applicable), and compressors shall have molded composite handles.
- d. Handles shall be UV modified, composite. They shall be permanently attached, and recessed into the panel.
- e. Screws on the vertical portion of all removable access panel shall engage into heat resistant, molded composite collars.
- f. Collars shall be removable and easily replaceable using manufacturer recommended parts.

H. (23 81 19.13.H.) Coils:

1. Standard industry proven Aluminum Fin-Copper Tube Coils:
 - a. Standard evaporator and condenser coils shall have aluminum lanced plate fins mechanically bonded to seamless internally grooved copper tubes with all joints brazed.
 - b. Evaporator coils shall be leak tested to 150 psig, pressure tested to 450 psig, and qualified to UL 1995 burst test at 1775 psig.
 - c. Condenser coils shall be leak tested to 150 psig, pressure tested to 650 psig, and qualified to UL 1995 burst test at 1980 psig.
2. Optional Pre-coated aluminum-fin condenser coils (3 Phase Models Only):
 - a. Shall have a durable epoxy-phenolic coating to provide protection in mildly corrosive coastal environments.
 - b. Coating shall be applied to the aluminum fin stock prior to the fin stamping process to create an inert barrier between the aluminum fin and copper tube.
 - c. Epoxy-phenolic barrier shall minimize galvanic action between dissimilar metals.
 - d. Corrosion durability of fin stock shall be confirmed through testing to be no less than 1000 hours salt spray per ASTM B117-90.
 - e. Corrosion durability of fin stock shall be confirmed through testing to have no visible corrosion after 48 hour immersion in a room temperature solution of 5% salt, 1% acetic acid.
 - f. Fin stock coating shall pass 2000 hours of the following: one week exposure in the prohesion chamber followed by one week of accelerated ultraviolet light testing. Prohesion chamber: the solution shall contain 3.5% sodium chloride and 0.35% ammonium sulfate. The exposure cycle is one hour of salt fog application at ambient followed by one hour drying at 95°F (35°C).

3. Optional Copper-fin evaporator and condenser coils (3 Phase Models Only):
 - a. Shall be constructed of copper fins mechanically bonded to copper tubes and copper tube sheets.
 - b. Galvanized steel tube sheets shall not be acceptable.
 - c. A polymer strip shall prevent coil assembly from contacting the sheet metal coil pan to minimize potential for galvanic corrosion between coil and pan.

4. Optional E-coated aluminum-fin evaporator and condenser coils (3 Phase Models Only):
 - a. Shall have a flexible epoxy polymer coating uniformly applied to all coil surface areas without material bridging between fins.
 - b. Coating process shall ensure complete coil encapsulation of tubes, fins and headers.
 - c. Color shall be high gloss black with gloss per ASTM D523-89.
 - d. Uniform dry film thickness from 0.8 to 1.2 mil on all surface areas including fin edges.
 - e. Superior hardness characteristics of 2H per ASTM D3363-92A and cross-hatch adhesion of 4B-5B per ASTM D3359-93.
 - f. Impact resistance shall be up to 160 in. lb (ASTM D2794-93).
 - g. Humidity and water immersion resistance shall be up to minimum 1000 and 250 hours respectively (ASTM D2247-92 and ASTM D870-92).
 - h. Corrosion durability shall be confirmed through testing to be no less than 1000 hours salt spray per ASTM B117-90.

I. (23 81 19.13.I.) Refrigerant Components:

1. Refrigerant circuit shall include the following control, safety, and maintenance features:
 - a. TXV cooling metering system on all models shall include a multiple feed distribution system. Fixed heating orifice metering system on all 04-06 models shall include a multiple feed distribution system that optimizes coil performance.
 - b. Refrigerant filter drier - Solid core design.
 - c. Service gage connections on suction and discharge lines.
 - d. Pressure gage access through a specially designed access port in the top panel of the unit.
 - e. Suction line accumulator to provide protection in all operating modes from cooling, heating and reverse cycle switching.

2. There shall be gage line access port in the skin of the rooftop, covered by a black, removable plug.
 - a. The plug shall be easy to remove and replace.
 - b. When the plug is removed, the gage access port shall enable maintenance personnel to route their pressure gage lines.
 - c. This gage access port shall facilitate correct and accurate condenser pressure readings by enabling the reading with the compressor access panel on.
 - d. The plug shall be made of a leak proof, UV-resistant, composite material.
 3. Compressors:
 - a. Unit shall use fully hermetic, heat pump duty two stage scroll compressor on single circuit independent refrigeration circuit.
 - b. Compressor motors shall be cooled by refrigerant gas passing through motor windings.
 - c. Compressors shall be internally protected from high discharge temperature conditions.
 - d. Compressors shall be protected from an over-temperature and over-ampereage conditions by an internal, motor overload device.
 - e. Compressor shall be factory mounted on rubber grommets.
 - f. Compressor motors shall have internal line break thermal, current overload and high pressure differential protection.
 - g. Crankcase heaters shall not be required for normal operating range, unless required by compressor manufacturer due to refrigerant charge limits.
 - J. (23 81 19.13.J.) Filter Section:
 1. Filters access is specified in the unit cabinet section of this specification.
 2. Filters shall be held in place by a pivoting filter tray, facilitating easy removal and installation.
 3. Shall consist of factory installed, low velocity, throw-away 2-in. thick fiberglass filters.
 4. Filters shall be standard, commercially available sizes.
 5. Only one size filter per unit is allowed.
 - K. (23 81 19.13.K.) Evaporator Fan and Motor with EcoBlue™ Technology:
 1. Direct Drive Evaporator fan motor:
 - a. Shall be a ECM motor design.
 - b. Shall have permanently lubricated bearings.
 - c. Shall have inherent automatic-reset thermal overload protection.
 - d. Shall have slow ramp up to speed capabilities.
 - e. Shall require no fan/motor belts for operation, adjustments and or initial fan speed set up.
 - f. Fan DC voltage set up on Unit Control Board can eliminate the need of removal of blower access door, required on conventional belt drive systems.
 - g. Shall be internally protected from electrical phase reversal and loss.
 2. Evaporator Fan:
 - a. Shall be easily set with selection switch and adjustment pot on unit control board or through SystemVu™ controller.
 - b. On all sizes 04-06 which have two stage cooling capacity control, the indoor fan speed is automatically controlled to meet the AHRI performance requirement with 75% low fan speed and 100% at full fan speed operation.
 - c. Blower fan shall be a Vane Axial fan design with 75% less moving parts than a conventional belt drive system.
 - d. Shall be constructed of a cast aluminum stator and high impact composite material on rotor and air inlet casing.
 - e. Shall be a patented / pending design with a corrosion resistant material and dynamically balanced.
 - f. Shall have slow ramp up to speed capabilities to help reduce sound and comfort issues typically associated with single speed belt drive systems.
 - g. Shall be a slide out design with two screw removal.
 3. Shall include an easily accessible Unit Control Board to conveniently and safely provide connection points for vital control functions such as: smoke detectors, phase monitor, economizer, thermostat, DDC control options, and low and high pressure switches. Controller shall also provide an intuitive means to adjust the indoor fan speed through a simple switch and pot adjustment design.
- L. (23 81 19.13.L.) Condenser Fans and Motors:
 1. Condenser fan motors:
 - a. Shall be a totally enclosed motor.
 - b. Shall use permanently lubricated bearings.
 - c. Shall have inherent thermal overload protection with an automatic reset feature.
 - d. Shall use a shaft-down design on all sizes.
 2. Condenser Fans:
 - a. Shall be a direct-driven propeller type fan constructed of high impact composite material.
 - b. Shall have high impact composite blades completely formed into one piece without blade fasteners or connectors and shall be dynamically balanced.

M. (23 81 19.13.M.) Special Features Options and Accessories:

1. Integrated EconoMi\$er® IV, EconoMi\$er2, and EconoMi\$er X low leak rate models. (EconoMi\$er2, and EconoMi\$er X are factory-installed on 3 phase models only. All are field-installed on all 3 and 1 phase models.)
 - a. Integrated, gear driven opposing modulating blade design type capable of simultaneous economizer and compressor operation.
 - b. Independent modules for vertical or horizontal return configuration shall be available. Vertical return modules shall be available as a factory installed option.
 - c. Damper blades shall be galvanized steel with composite gears. Plastic or composite blades on intake or return shall not be acceptable.
 - d. Shall include all hardware and controls to provide free cooling with outdoor air when temperature and/or humidity are below setpoints.
 - e. Shall be equipped with gear driven dampers for both the outdoor ventilation air and the return air for positive air stream control.
 - f. Low leak rate shall be equipped with dampers not to exceed 2% leakage at 1 in. wg pressure differential.
 - g. Economizer controller on EconoMi\$er IV (field-installed only) models shall be the W7212 that provides:
 - 1) Combined minimum and DCV maximum damper position potentiometers with compressor staging relay.
 - 2) Functions with solid-state analog enthalpy or dry bulb changeover control sensing.
 - 3) Contain LED indicates for: when free cooling is available, when module is in DCV mode, when exhaust fan contact is closed.
 - h. Economizer controller on EconoMi\$er X models shall be the W7220 that provides:
 - 1) 2-line LCD interface screen for setup, configuration and troubleshooting.
 - 2) On-board Fault Detection and Diagnostics (FDD) that senses and alerts when the economizer is not operating properly, per California Title 24, ASHRAE 90.1 and IECC¹.
 - 3) Sensor failure loss of communication identification.
 - 4) Automatic sensor detection.
 - 5) Capabilities for use with multiple-speed or single speed indoor fan systems.
 - 6) Utilize digital sensors: Dry bulb and Enthalpy.

- i. Economizer controller on EconoMi\$er2 models with RTU Open or SystemVu controllers shall be a 4-20mA design controlled directly by the controller. RTU Open and SystemVu controllers meet California Title 24, ASHRAE 90.1 and IECC Fault Detection and Diagnostic (FDD) requirements.
- j. Shall be capable of introducing up to 100% outdoor air.
- k. Shall be equipped with a barometric relief damper capable of relieving up to 100% return air and contain seals that meet ASHRAE 90.1 requirements.
- l. Shall be designed to close damper(s) during loss-of-power situations with spring return built into motor.
- m. Dry bulb outdoor air temperature sensor shall be provided as standard. Enthalpy sensor is also available on factory installed only. Outdoor air sensor setpoint shall be adjustable and shall range from 40°F to 100°F (4°C to 38°C). Additional sensor options shall be available as accessories.
- n. The economizer controller shall also provide control of an accessory power exhaust unit function. Factory set at 100%, with a range of 0% to 100%.
- o. The economizer shall maintain minimum airflow into the building during occupied period and provide design ventilation rate for full occupancy.
- p. Dampers shall be completely closed when the unit is in the unoccupied mode.
- q. Economizer controller shall accept a 2 to 10 vdc CO₂ sensor input for IAQ/DCV control. In this mode, dampers shall modulate the outdoor air damper to provide ventilation based on the sensor input.
- r. Compressor lockout temperature on W7220 control is adjustable from -45°F (-43°C) to 80°F (27°C), set at a factory default of 32°F (0°C). W7212 control opens at 35°F (2°C) and closes at 50°F (10°C).
- s. Actuator shall be direct coupled to economizer gear. No linkage arms or control rods shall be acceptable.
- t. Economizer controller shall provide indications when in free cooling mode, in the DCV mode, or the exhaust fan contact is closed.
2. Integrated EconoMi\$er2, and EconoMi\$er X Ultra Low Leak rate models. (Factory installed on 3 phase models only. Field installed on all 3 and 1 phase models.)
 - a. Integrated, gear driven opposing modulating blade design type capable of simultaneous economizer and compressor operation.
 - b. Independent modules for vertical or horizontal return configuration shall be available.

1. IECC is a registered trademark of the International Code Council, Inc.

Vertical return modules shall be available as a factory-installed option.

- c. Damper blades shall be galvanized steel with composite gears. Plastic or composite blades on intake or return shall not be acceptable.
- d. Shall include all hardware and controls to provide free cooling with outdoor air when temperature and/or humidity are below setpoints.
- e. Shall be equipped with gear driven dampers for both the outdoor ventilation air and the return air for positive air stream control.
- f. Ultra Low Leak design meets California Title 24 section 140.4 and ASHRAE 90.1 requirements for 4 cfm per sq. ft on the outside air dampers and 10 cfm per sq. ft on the return dampers.
- g. Economizer controller on EconoMi\$er X models shall be the W7220 that provides:
 - 1) 2-line LCD interface screen for setup, configuration and troubleshooting.
 - 2) On-board Fault Detection and Diagnostics (FDD) that senses and alerts when the economizer is not operating properly, per California Title 24, ASHRAE 90.1 and IECC.
 - 3) Sensor failure loss of communication identification.
 - 4) Automatic sensor detection.
 - 5) Capabilities for use with multiple-speed indoor fan systems.
 - 6) Utilize digital sensors: Dry bulb and Enthalpy.
- h. Economizer controller on EconoMi\$er2 models with RTU Open or SystemVu controls shall be a 4 to 20mA design controlled directly by the controller. RTU Open and SystemVu meet California Title 24, ASHRAE 90.1 and IECC Fault Detection and Diagnostic (FDD) requirements.
- i. Shall be capable of introducing up to 100% outdoor air.
- j. Shall be equipped with a barometric relief damper capable of relieving up to 100% return air and contain seals that meet ASHRAE 90.1 requirements.
- k. Shall be designed to close damper(s) during loss-of-power situations with spring return built into motor.
- l. Dry bulb outdoor air temperature sensor shall be provided as standard. Enthalpy sensor is also available on factory installed only. Outdoor air sensor setpoint shall be adjustable and shall range from 40°F to 100°F (4°C to 38°C). Additional sensor options shall be available as accessories.
- m. The economizer controller shall also provide control of an accessory power exhaust unit

function. Factory set at 100%, with a range of 0% to 100%.

- n. The economizer shall maintain minimum air-flow into the building during occupied period and provide design ventilation rate for full occupancy.
 - o. Dampers shall be completely closed when the unit is in the unoccupied mode.
 - p. Economizer controller shall accept a 2 to 10 vdc CO₂ sensor input for IAQ/DCV control. In this mode, dampers shall modulate the outdoor air damper to provide ventilation based on the sensor input.
 - q. Compressor lockout temperature on W7220 control is adjustable from -45°F (-43°C) to 80°F (27°C), set at a factory default of 32°F (0°C). W7212 control opens at 35°F (2°C) and closes at 50°F (10°C).
 - r. Actuator shall be direct coupled to economizer gear. No linkage arms or control rods shall be acceptable.
 - s. Economizer controller shall provide indications when in free cooling mode, in the DCV mode, or the exhaust fan contact is closed.
3. Two-Position Damper (field-installed only):
- a. Damper shall be a Two-Position Damper. Damper travel shall be from the full closed position to the field adjustable %-open setpoint.
 - b. Damper shall include adjustable damper travel from 25% to 100% (full open).
 - c. Damper shall include single or dual blade, gear driven dampers and actuator motor.
 - d. Actuator shall be direct coupled to damper gear. No linkage arms or control rods shall be acceptable.
 - e. Damper will admit up to 100% outdoor air for applicable rooftop units.
 - f. Damper shall close upon indoor (evaporator) fan shutoff and/or loss of power.
 - g. The damper actuator shall plug into the rooftop unit's wiring harness plug. No hard wiring shall be required.
 - h. Outside air hood shall include aluminum water entrainment filter.
4. Manual damper (field-installed only):
- a. Manual damper package shall consist of damper, air inlet screen, and rain hood which can be pre-set to admit up to 25% or 50% outdoor air for year round ventilation.
5. Low Ambient Control Package:
- a. Controller shall control coil head pressure by condenser fan speed modulation or condenser fan cycling and wind baffles.
 - b. Shall consist of solid-state control and condenser coil temperature sensor to maintain

- condensing temperature between 90°F (32°C) and 110°F (43°C) at outdoor ambient temperatures down to -20°F (-29°C).
6. Condenser Coil Hail Guard Assembly (Factory-installed on 3 Phase Models Only. Field-installed on all 3 and 1 Phase Models.)
 - a. Shall protect against damage from hail.
 - b. Shall be either hood style or louvered.
 7. Unit-Mounted, Non-Fused Disconnect Switch (Available on units with MOCPS of 80 amps or less):
 - a. Switch shall be factory installed, internally mounted.
 - b. National Electric Code (NEC) and UL approved non-fused switch shall provide unit power shutoff.
 - c. Shall be accessible from outside the unit.
 - d. Shall provide local shutdown and lockout capability.
 - e. Sized only for the unit as ordered from the factory. Does not accommodate field-installed devices.
 8. HACR Breaker:
 - a. These manual reset devices provide overload and short circuit protection for the unit. Factory wired and mounted with the units, with access cover to help provide environmental protection. On 575V applications, HACR breaker can only be used with WYE power distribution systems. Use on Delta power distribution systems is prohibited.
 - b. Sized only for the unit as ordered from the factory. Does not accommodate field-installed devices.
 9. Convenience Outlet:
 - a. Powered convenience outlet: (3 Phase Models Only)
 - 1) Outlet shall be powered from main line power to the rooftop unit.
 - 2) Outlet shall be powered from line side or load side of disconnect by installing contractor, as required by code. If outlet is powered from load side of disconnect, unit electrical ratings shall be UL certified and rated for additional outlet amperage.
 - 3) Outlet shall be factory-installed and internally mounted with easily accessible 115-v female receptacle.
 - 4) Outlet shall include 15 amp GFI receptacles with independent fuse protection.
 - 5) Voltage required to operate convenience outlet shall be provided by a factory installed step-down transformer.
 - 6) Outlet shall be accessible from outside the unit.
 - 7) Outlet shall include a field installed “Wet in Use” cover.
 - b. Factory-Installed Non-Powered convenience outlet:
 - 1) Outlet shall be powered from a separate 115/120v power source.
 - 2) A transformer shall not be included.
 - 3) Outlet shall be factory-installed and internally mounted with easily accessible 115-v female receptacle.
 - 4) Outlet shall include 15 amp GFI receptacles with independent fuse protection.
 - 5) Outlet shall be accessible from outside the unit.
 - 6) Outlet shall include a field installed “Wet in Use” cover.
 - c. Field-Installed non-powered convenience outlet:
 - 1) Outlet shall be powered from a separate 115/120v power source.
 - 2) A transformer shall not be included.
 - 3) Outlet shall be field-installed and internally mounted with easily accessible 115-v female receptacle.
 - 4) Outlet shall include 20 amp GFI receptacles. This kit provides a flexible installation method which allows code compliance for height requirements of the GFCI outlet from the finished roof surface as well as the capability to relocate the outlet to a more convenient location.
 - 5) Outlet shall be accessible from outside the unit.
 - 6) Outlet shall include a field installed “Wet in Use” cover.
 10. Thru-the-Base Connectors:
 - a. Kits shall provide connectors to permit gas and electrical connections to be brought to the unit through the unit basepan.
 - b. Minimum of four connection locations per unit.
 11. Propeller Power Exhaust:
 - a. Power exhaust shall be used in conjunction with an integrated economizer.
 - b. Independent modules for vertical or horizontal return configurations shall be available.
 - c. Horizontal power exhaust is shall be mounted in return ductwork.
 - d. Power exhaust shall be controlled by economizer controller operation. Exhaust fans shall be energized when dampers open past the 0 to 100% adjustable setpoint on the economizer control.
 12. Roof Curbs (Vertical):
 - a. Full perimeter roof curb with exhaust capability providing separate air streams for energy recovery from the exhaust air without supply air contamination.

- b. Formed galvanized steel with wood nailer strip and shall be capable of supporting entire unit weight.
 - c. Permits installation and securing of ductwork to curb prior to mounting unit on the curb.
13. Outdoor Air Enthalpy Sensor:
- a. The outdoor air enthalpy sensor shall be used to provide single enthalpy control. When used in conjunction with a return air enthalpy sensor, the unit will provide differential enthalpy control. The sensor allows the unit to determine if outside air is suitable for free cooling.
14. Return Air Enthalpy Sensor:
- a. The return air enthalpy sensor shall be used in conjunction with an outdoor air enthalpy sensor to provide differential enthalpy control.
15. Indoor Air Quality (CO₂) Sensor:
- a. Shall be able to provide demand ventilation indoor air quality (IAQ) control.
 - b. The IAQ sensor shall be available in duct mount, wall mount, or wall mount with LED display. The setpoint shall have adjustment capability.
16. Smoke detectors (factory-installed only):
- a. Shall be a four-wire controller and detector.
 - b. Shall be environmental compensated with differential sensing for reliable, stable, and drift-free sensitivity.
 - c. Shall use magnet-activated test/reset sensor switches.
 - d. Shall have tool-less connection terminal access.
 - e. Shall have a recessed momentary switch for testing and resetting the detector.
 - f. Controller shall include:
 - 1) One set of normally open alarm initiation contacts for connection to an initiating device circuit on a fire alarm control panel.
 - 2) Two Form-C auxiliary alarm relays for interface with rooftop unit or other equipment.
 - 3) One Form-C supervision (trouble) relay to control the operation of the Trouble LED on a remote test/reset station.
 - 4) Capable of direct connection to two individual detector modules.
 - 5) Can be wired to up to 14 other duct smoke detectors for multiple fan shut-down applications.
17. Winter Start Kit:
- a. Shall contain a bypass device around the low pressure switch.
 - b. Shall be required when mechanical cooling is required down to 25°F (-4°C).
 - c. Shall not be required to operate on an economizer when below an outdoor ambient of 35°F (2°C).
18. Time Guard Control Circuit:
- a. Shall prevent compressor short-cycling by providing a 5 minute delay (±2 minutes) before restarting a compressor after shut-down for any reason.
 - b. One device shall be required per compressor.
19. Hinged Access Panels:
- a. Shall provide easy access through integrated quarter turn latches.
 - b. Shall be on major panels of: filter, control box, fan motor, and compressor.
20. Condensate overflow switch:
- a. This sensor and related controller monitors the condensate level in the drain pan and shuts down compression operation when overflow conditions occur. It includes:
 - 1) Indicator light — solid red (more than 10 seconds on water contact – compressors disabled), blinking red (sensor disconnected).
 - 2) 10 second delay to break — eliminates nuisance trips from splashing or waves in pan (sensor needs 10 seconds of constant water contact before tripping).
 - 3) Disables the compressor(s) operation when condensate plug is detected, but still allows fans to run for economizer.
21. Foil Faced Insulation:
- a. Throughout unit cabinet air stream, non-fibrous and cleanable foil faced insulation is used.
22. MERV-8 Return Air filters:
- a. Factory option to upgrade standard unit filters to MERV-8 filters.
23. Phase Monitor Control:
- a. Shall monitor the sequence of three phase electrical system to provide a phase reversal protection.
 - b. Shall monitor the three phase voltage inputs to provide a phase loss protection for the three phase device.
 - c. Will work on either a Delta or Wye power connection.
24. Horn/Strobe Annunciator:
- a. Provides an audible/visual signaling device for use with factory-installed option or field installed accessory smoke detectors.
 - 1) Requires installation of a field-supplied 24-v transformer suitable for 4.2 VA (AC) or 3.0 VA (DC) per horn/strobe accessory.

- 2) Requires field-supplied electrical box, North American 1-gang box, 2-in. (51 mm) x 4-in. (102 mm).
 - 3) Shall have a clear colored lens.
25. Electric Heat:
- a. Heating Section:
 - 1) Heater element open coil resistance wire, nickel-chrome alloy, 0.29-in. inside diameter, strung through ceramic insulators mounted on metal frame. Coil ends are staked and welded to terminal screw slots.
 - 2) Heater assemblies are provided with integral fusing for protection of internal heater circuits not exceeding 48 amps each. Auto reset thermo limit controls, magnetic heater contactors (24-v coil) and terminal block all mounted in electric heater control box (minimum 18 ga galvanized steel) attached to end of heater assembly.

