



Turn to the experts

Product Data

Single-Duct Retrofit Terminal Units

40 to 3700 cfm

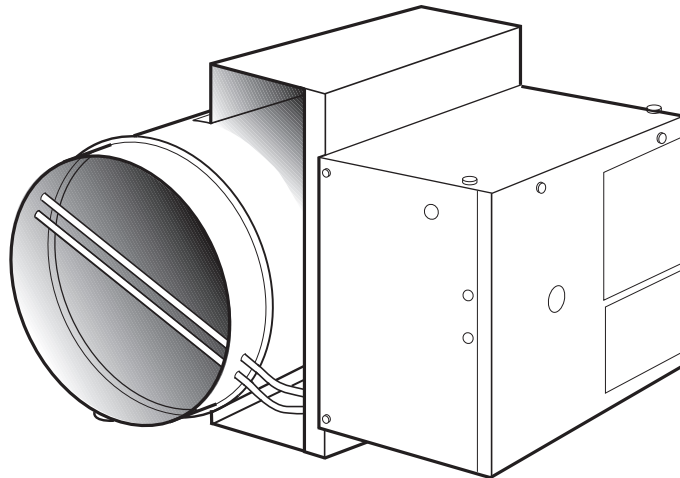

35J
Single-Duct Retrofit Terminal Units for Variable
Air Volume Systems

The 35J round tube single duct variable air volume (VAV) unit provides cooling only to meet retrofit and special application needs. It is designed to allow maximum flexibility in configuration and control.

The 35J retrofit terminal units offer:

- Unit casing of 22-gage galvanized steel construction (optional 20-gage; optional 304 stainless steel)
- Sizes ranging from 4 to 16 in. diameters for round inlets and outlets
- Suitable for low-pressure, medium-pressure and high-pressure applications
- Delrin® damper bearings are self-lubricating and unaffected by temperature and humidity
- Airflow capacities up to 3700 cfm
- Tested in accordance with AHRI (Air Conditioning, Heating and Refrigeration Institute) Standard 880

Application flexibility

The 35J unit is offered in 10 sizes covering an air delivery range from 40 to 3700 cfm. The basic unit is a short, high performance unit with the industry standard single-blade damper. Minimal leakage assures optimum utilization of supplied airflow. The small size of the unit ensures an easy fit in all applications; all units have round inlets and outlets.

The unit casing is 22-gage galvanized steel standard with 20-gage and stainless steel options. The casings meet the requirements of UL-181 (Underwriters' Laboratories) and NFPA-90A (National Fire Protection Association).

The 35J retrofit unit is ideal for converting a mechanical terminal unit into a VAV terminal unit. Designed to retrofit constant volume units, the 35J unit offers compatible controls for most building automation systems and installation convenience. With 35J VAV terminals in place, building owners can make use of a variety of fan volume control options.

A major concern when retrofitting is downtime. Since the 35J terminal unit is compact and can be installed through the ceiling grid, installation costs and downtime are reduced.

Additional uses for the 35J unit are in exhaust and non-reheat supply applications. The stainless steel 35J unit is ideal for lab applications where the exhaust consists of corrosive materials. Supply applications might include any situation where a round-to-round connection is desired.

Superior control offerings

Each 35J unit is supplied with a linear averaging flow probe as a standard feature. This probe offers a flow averaging capability and results in flow sensing capability equal to any competitive unit.

Control offerings include: pressure-independent pneumatic, analog electronic, 3V™ variable volume and tem-

perature (VVT®), and ComfortID™ VAV (variable air volume). Both VVT and VAV controls are communicating product integrated controls (PIC).

The PIC units provide a control option compatible with the Carrier Comfort Network® (CCN) controls.

Pneumatic control units utilize a standard linear damper actuator, which when combined with the 90-degree damper actuator, allows a simple switchover from normally open to normally closed applications without moving any components.

Electronic control units feature a factory-installed enclosure that provides easy access for field connections.

Designed for easy installation

Units have round inlets and outlets. All inlets have a slightly undersized collar to fit standard spiral and flex duct. Duct dimensions for 35 Series units are the same as Carrier 45 Series fan-powered boxes, for easy interchangeability.

Table of contents

	Page
Features/Benefits	2
Model Number Nomenclature	3
Physical Data	4
Options and Accessories	4
Dimensions	6
Selection Procedure	5
Performance Data	8
Application Data	11
Guide Specifications	13

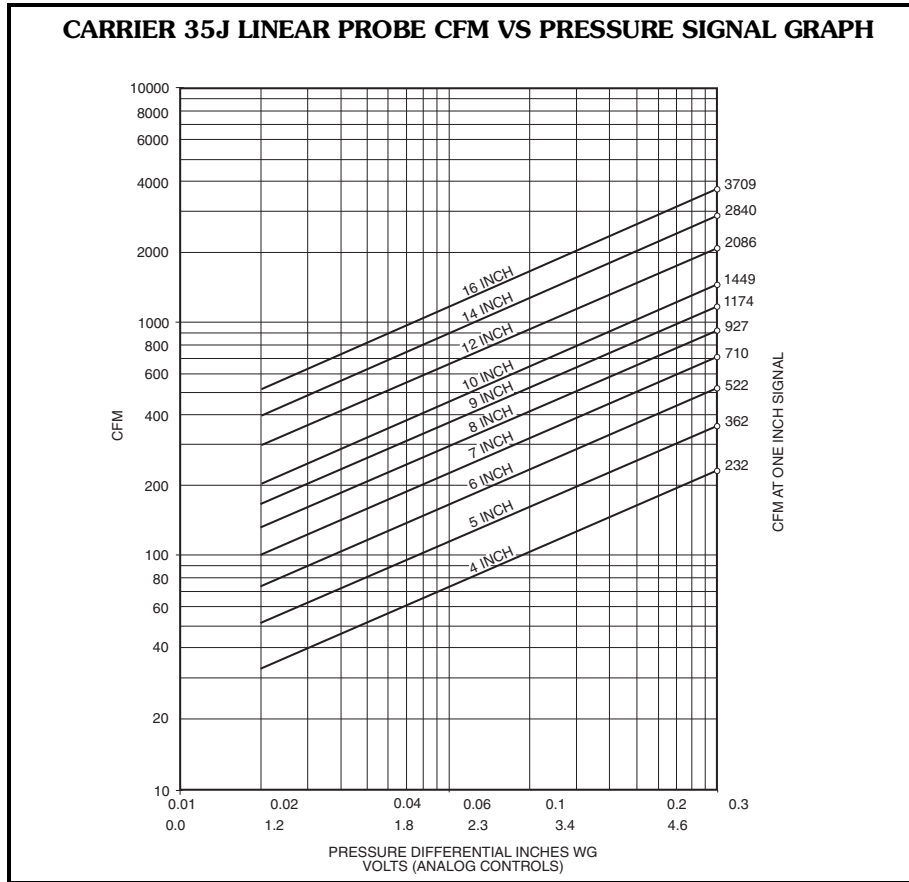

Model number nomenclature

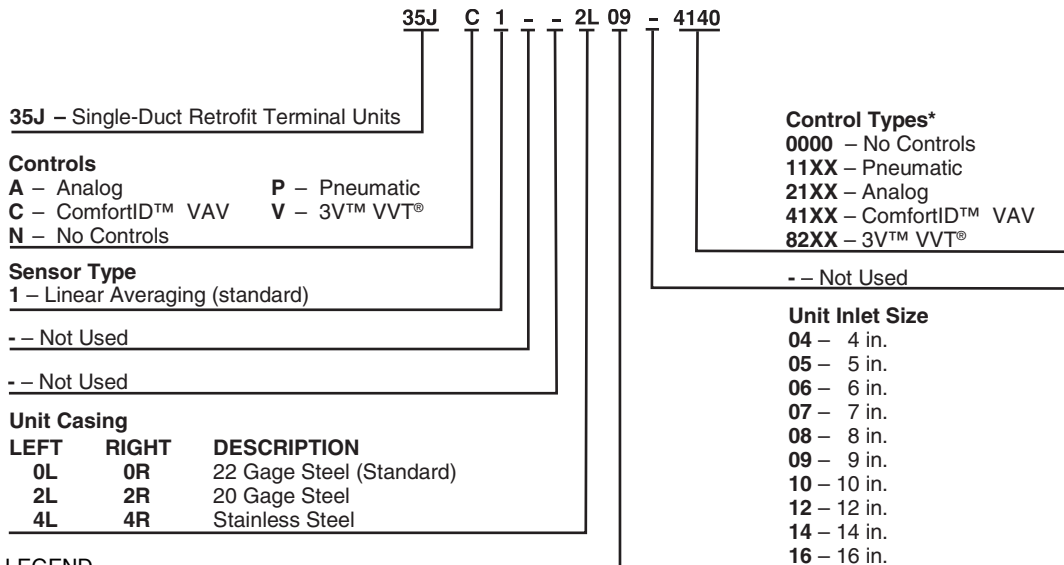

LEGEND

VAV — Variable Air Volume
VVT — Variable Volume and Temperature

*See page 4 for complete control codes.

35J SIZE	UNIT ONLY (lb)	WITH PNEUMATIC CONTROLS (lb)	WITH DDC OR ANALOG CONTROLS (lb)
04,05,06	12	16	21
07,08	14	18	23
09,10	19	23	28
12	24	28	33
14	32	36	41
16	36	40	45

LEGEND

DDC — Direct Digital Controls

NOTE: Data is based on the following conditions:

1. Unit casing is 22 gage.
2. Unit insulation is 1/2-in. thick, 1.5-lb Tuf-Skin Rx™ insulation.
3. Units rated with standard linear flow sensor.

Options and accessories

Control options

The 35J single-duct unit is offered with a wide variety of factory-mounted controls which regulate the volume of air delivery from the unit and respond to cooling and heating load requirements of the conditioned space. Stand-alone controls will fulfill the thermal requirements of a given control space. These devices are available in both pneumatic and electronic arrangements. The 3V™, VVT® and ComfortID™ VAV electronic controls are communicating PIC (product integrated controls) which are integrated with the building system. The PIC controls are compatible with the CCN network. A number of direct digital control (DDC) packages by others are available for consignment mounting, as indicated.

The control offerings are identified as follows:

- 35JA: Analog Electronic
- 35JC: ComfortID™ VAV Electronic Controls (compatible with CCN network)
- 35JP: Pneumatic
- 35JV: 3V™ VVT Electronic Controls (compatible with CCN network)
- 35JN: No Controls or DDC by Others

Each control approach offers a variety of operating functions; a control package number identifies combinations of control functions. The following tables list the basic function arrangements for each of the basic control offerings. Because of the variety of functions available, circuit diagrams, operating sequences, and function descriptions are contained in separate Application Data publications. Refer to the specific control publication for details.

Analog electronic controls

All analog control arrangements include a standard linear inlet flow sensor, 24-v transformer (optional), control enclosure and wall thermostat to match the control type.

2100	Heating control*
2101	Cooling control*

* Includes thermostat.

Analog electric controls

3100	Temperature responsive control†
-------------	---------------------------------

† Does not include thermostat.

Pneumatic controls

All control packages are pressure independent (unless otherwise noted) and available with or without dual maximum airflow, cooling maximum airflow and dual minimum airflow. All control arrangements include a standard linear inlet flow sensor.

1102	(Single function controller): DA-NO
1103	(Single function controller): RA-NC
1104	(Multi-function controller): DA-NO
1105	(Multi-function controller): DA-NC
1106	(Multi-function controller): RA-NO
1107	(Multi-function controller): RA-NC

LEGEND

DA— Direct-Acting Thermostat
RA— Reverse-Acting Thermostat
NO— Normally Open Damper Position
NC— Normally Closed Damper Position

The single function controller provides single functions, i.e., DA-NO. Multi-function controllers are capable of providing DA-NO, DA-NC, RA-NC or RA-NO functions.

ComfortID™, VAV controls

ComfortID controls are factory-installed in a control enclosure. Factory-mounted transformers are available as an option. Thermostats are supplied separately as a field-installed accessory. ComfortID control packages must be used in combination with a thermostat. Thermostats are not included in the package.

4140	Cooling only
4145	Cooling only with supply/return tracking
4150	Return air damper

Control type 4145 must be matched with a unit with control type 4150. Thermostat is not included, it should be ordered separately from the Commercial Products Systems and Controls master price page and shipped directly to job site.

3V™, VVT® controls

Variable volume and temperature (VVT) controls are factory-installed in a control enclosure. Factory-mounted

transformers are available as an option. Thermostats are supplied separately as a field-installed accessory.

8220	Pressure dependent, cooling only
8230	Bypass control

Accessory ComfortID and 3V thermostats

Thermostat: 33ZCT55SPT: RT (room temperature) sensor, with override only.

Thermostat: 33ZCT56SPT: RT (room temperature) sensor, with set point adjust and override.

Thermostat: 33ZCT59SPT: RT (room temperature) sensor, with set point adjust, override and LCD display.

Inlet Air Temperature Sensor: 33ZCSENPAT (required only if linkage unavailable)

NOTE: Field-installed accessory VAV and VVT components, such as thermostats, must be ordered separately from the Commercial Products Systems and Controls master price page and shipped directly to the jobsite.

No controls or direct digital controls (by others)

Control packages are field-supplied for factory mounting, unless otherwise noted. All DDC control arrangements include a standard linear inlet flow sensor, transformer to 24 volts and control enclosure. Contact Carrier for detail about mounting field-supplied controls.

0000	35J box only
D000	35J box with control enclosure
D001	Field supplied controls with control enclosure and no transformer

Selection procedure

Refer to the Carrier Air Terminal Builder program for information to determine specific unit sizing.

See the performance data tables in this document for air-flow performance information.

35JA,JC,JV UNIT WITH ELECTRONIC CONTROLS 35JN UNIT WITH CONTROLS ENCLOSURE (DDC BY OTHERS)

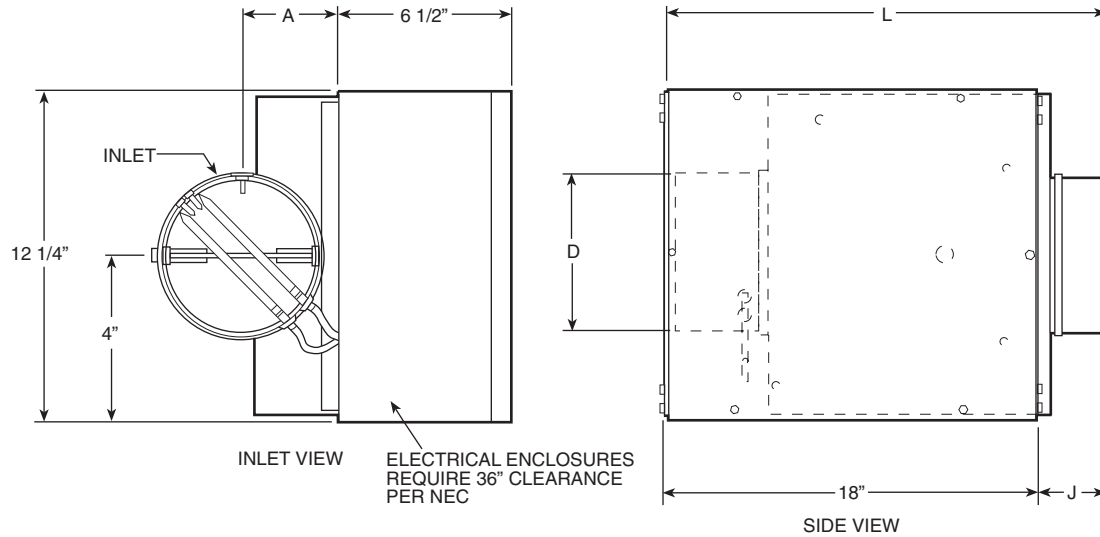

35J UNIT SIZE	A	D	J	L
04	$3\frac{9}{16}$	$3\frac{7}{8}$	$1\frac{11}{32}$	18
05	$3\frac{9}{16}$	$4\frac{7}{8}$	$1\frac{11}{32}$	18
06	$3\frac{9}{16}$	$5\frac{7}{8}$	$1\frac{11}{32}$	16
07	$4\frac{1}{16}$	$6\frac{7}{8}$	$1\frac{11}{32}$	16
08	$4\frac{9}{16}$	$7\frac{7}{8}$	$1\frac{11}{32}$	16
09	$5\frac{1}{16}$	$8\frac{7}{8}$	$2\frac{11}{32}$	20
10	$5\frac{9}{16}$	$9\frac{7}{8}$	$2\frac{11}{32}$	20
12	$6\frac{9}{16}$	$11\frac{7}{8}$	$2\frac{11}{32}$	20
14	$7\frac{9}{16}$	$13\frac{7}{8}$	$4\frac{11}{32}$	24
16	$8\frac{9}{16}$	$15\frac{7}{8}$	$4\frac{11}{32}$	24

LEGEND

DDC — Direct Digital Controls
NEC — National Electrical Code

NOTES:

- Dimensions are given in inches.
- 22-gage steel construction, stainless steel option.
- "D" dimension is diameter of inlet.
- Steel control enclosure for electronic components.
- Analog electric and factory mounted digital control packages for pressure dependent and pressure independent systems available.
- Sizes 04 and 05 require an inlet adapter.
- Units are ETL listed for adherence to UL429 for electrically operated valves for units with electronic controls.
- Right-hand unit with enclosure shown. Unit available in left-hand arrangement.

35JP WITH PNEUMATIC CONTROLS

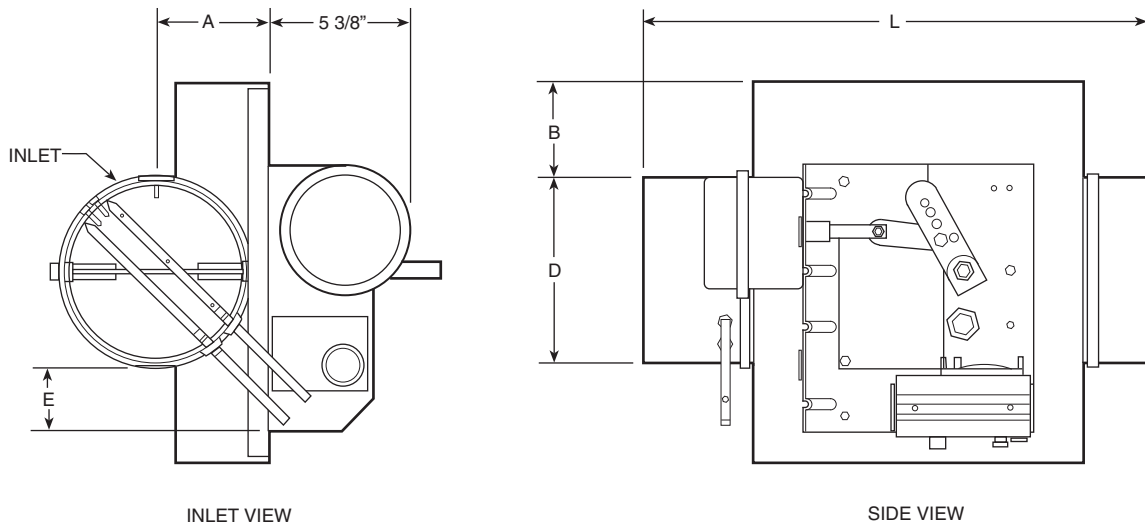

35J UNIT SIZE	A	B	D	E	L
04	$3\frac{9}{16}$	$4\frac{1}{16}$	$3\frac{7}{8}$	$1\frac{3}{8}$	18
05	$3\frac{9}{16}$	$3\frac{9}{16}$	$4\frac{7}{8}$	$1\frac{3}{8}$	18
06	$3\frac{9}{16}$	$3\frac{1}{16}$	$5\frac{7}{8}$	$1\frac{3}{8}$	16
07	$4\frac{1}{16}$	$2\frac{9}{16}$	$6\frac{7}{8}$	$\frac{7}{8}$	16
08	$4\frac{9}{16}$	$2\frac{1}{16}$	$7\frac{7}{8}$	$\frac{3}{8}$	16
09	$5\frac{1}{16}$	$1\frac{9}{16}$	$8\frac{7}{8}$	N/A	20
10	$5\frac{9}{16}$	$1\frac{1}{16}$	$9\frac{7}{8}$	N/A	20
12	$6\frac{9}{16}$	$\frac{1}{16}$	$11\frac{7}{8}$	N/A	20
14	$7\frac{9}{16}$	$\frac{1}{16}$	$13\frac{7}{8}$	N/A	24
16	$8\frac{9}{16}$	$\frac{1}{16}$	$15\frac{7}{8}$	N/A	24

LEGEND

- DDC** — Direct Digital Controls
- NEC** — National Electrical Code

NOTES:

1. Dimensions are given in inches.
2. 22-gage steel construction, 304 stainless steel option.
3. "D" dimension is diameter of inlet.
4. Variety of analog digital electronic control packages.
5. Sizes 04 and 05 require an inlet adapter.
6. Right-hand unit with enclosure shown. Unit available in left-hand arrangement.

35J BASIC PRESSURE DATA

INLET SIZE (in.) (area) (sq ft)	AIRFLOW (cfm)	MIN AIRFLOW (cfm)		MIN Ps (in. wg)
		All Except CCN	With CCN	Basic Unit Δ Ps
4 (0.09)	45	50 or 0	23 or 0	0.01
	110			0.05
	170			0.13
	230			0.24
5 (0.14)	75	75 or 0	36 or 0	0.01
	170			0.06
	265			0.14
	360			0.26
6 (0.20)	100	110 or 0	52 or 0	0.01
	240			0.05
	380			0.13
	520			0.25
7 (0.27)	150	140 or 0	71 or 0	0.01
	330			0.06
	525			0.14
	710			0.26
8 (0.35)	200	185 or 0	93 or 0	0.01
	440			0.06
	675			0.14
	925			0.26
9 (0.44)	250	240 or 0	117 or 0	0.01
	550			0.06
	875			0.15
	1200			0.28
10 (0.55)	300	290 or 0	145 or 0	0.01
	675			0.06
	1075			0.14
	1450			0.26
12 (0.78)	450	420 or 0	209 or 0	0.01
	1000			0.06
	1550			0.14
	2100			0.26
14 (1.07)	600	580 or 0	284 or 0	0.01
	1375			0.06
	2125			0.15
	2900			0.28
16 (1.40)	800	740 or 0	371 or 0	0.01
	1775			0.06
	2725			0.14
	3700			0.26

LEGEND

CCN — Carrier Comfort Network
DDC — Direct Digital Controls
Ps — Static Pressure

- The minimum cfm value is based on a signal of 0.03 in.wg differential pressure of the inlet airflow sensor. Some DDC controls supplied by others have differential limitations.
- Minimum Ps is measured at maximum airflow.

NOTES:

- ΔP_s is the difference in static pressure across the assembly with the damper fully open. Minimum inlet static pressure shown in the Basic Pressure Data table is the pressure required by a given size box at a specified airflow with the unit damper wide open. This pressure was measured by tests conducted in accordance with AHRI (Air Conditioning and Refrigeration Institute) Standard 880-98.

35J UNIT RADIATED SOUND POWER

35J UNIT SIZE	FLOW RATE		MIN ΔPs		0.5 in. wg ΔPs							1.0 in. wg ΔPs							2.0 in. wg ΔPs						
					Octave Band Sound Power, L _w							L _p	Octave Band Sound Power, L _w							L _p	Octave Band Sound Power, L _w				
	Cfm	L/s	in. wg	pa	2	3	4	5	6	7	NC	2	3	4	5	6	7	NC	2	3	4	5	6	7	NC
04	50	24	0.011	2.81	16	10	10	10	13	9	—	20	14	15	15	18	13	—	25	19	19	19	23	17	—
	110	52	0.055	13.59	33	27	28	29	32	26	—	37	32	32	33	36	30	—	42	36	37	38	41	34	—
	170	80	0.131	32.53	42	37	37	39	42	35	—	47	42	42	44	46	39	—	51	46	47	48	51	43	21
	230	109	0.239	59.50	49	44	44	46	48	41	—	53	48	49	51	53	45	23	58	53	53	55	58	49	28
05	75	35	0.011	2.82	21	14	12	13	16	11	—	26	19	16	17	20	15	—	30	23	20	21	25	19	—
	170	80	0.058	14.46	37	31	30	31	34	28	—	41	35	34	35	38	32	—	45	40	39	39	43	36	—
	265	125	0.141	35.21	45	40	40	41	43	37	—	50	44	44	45	48	41	—	54	49	49	49	53	45	23
	360	170	0.261	64.93	51	46	47	47	50	44	21	56	51	51	52	55	47	26	60	55	56	56	59	51	30
06	100	47	0.009	2.29	14	4	6	5	13	5	—	19	10	12	11	18	10	—	24	15	18	17	23	15	—
	240	113	0.053	13.19	35	27	28	28	34	26	—	40	33	34	34	38	32	—	45	38	40	40	43	37	—
	380	179	0.133	33.12	46	39	40	40	44	38	—	51	45	46	46	49	43	—	56	51	51	52	54	48	26
	520	245	0.249	61.98	53	48	48	49	51	46	22	59	53	53	54	56	51	28	64	59	59	60	61	56	34
07	150	71	0.012	2.88	15	5	9	10	16	8	—	20	11	15	15	21	14	—	26	17	21	21	26	19	—
	330	156	0.056	13.93	35	27	29	30	35	28	—	41	33	35	35	40	34	—	46	40	41	41	45	39	—
	525	248	0.142	35.26	47	40	41	42	45	40	—	53	47	47	47	51	45	21	58	53	53	53	56	51	28
	710	335	0.259	64.50	55	49	49	49	53	48	23	60	55	55	55	58	53	30	66	61	61	61	63	58	36
08	200	94	0.012	3.01	21	13	10	11	21	11	—	26	18	16	16	26	16	—	31	24	22	22	31	22	—
	440	208	0.059	14.59	39	28	30	31	35	30	—	44	34	37	37	40	36	—	49	40	43	42	45	41	—
	675	319	0.138	34.33	49	37	42	42	43	41	—	54	43	48	48	48	46	22	59	48	54	53	53	51	29
	925	437	0.259	64.47	56	43	50	50	49	49	24	61	49	56	56	54	54	31	66	55	62	61	59	59	38
09	250	118	0.012	2.97	22	12	12	11	19	12	—	27	17	18	17	24	18	—	32	22	24	22	29	23	—
	550	260	0.058	14.39	40	32	32	31	37	31	—	45	37	38	37	42	37	—	50	43	44	43	47	42	—
	875	413	0.146	36.42	51	44	44	43	47	43	—	56	49	49	49	52	48	24	60	55	55	54	57	54	30
	1200	566	0.275	68.51	58	52	51	51	55	50	26	63	57	57	57	60	56	32	68	63	63	63	64	61	39
10	300	142	0.011	2.75	16	7	9	10	18	1	—	21	14	15	16	24	8	—	27	20	22	22	29	14	—
	675	319	0.056	13.94	38	30	31	31	37	27	—	43	36	37	37	42	34	—	49	43	44	43	47	40	—
	1075	507	0.142	35.37	50	43	44	44	48	42	—	56	49	50	49	53	49	24	62	56	56	55	58	55	31
	1450	684	0.259	64.35	58	51	52	51	55	52	26	64	58	58	57	60	58	33	70	64	65	63	65	65	40
12	450	212	0.012	3.01	24	14	15	13	21	12	—	29	20	21	18	26	18	—	35	26	27	24	31	24	—
	1000	472	0.060	14.86	43	34	35	34	39	33	—	48	40	41	39	44	39	—	53	46	47	45	49	45	20
	1550	731	0.143	35.71	53	45	46	45	49	45	20	58	51	52	51	54	51	26	63	57	58	56	59	57	32
	2100	991	0.263	65.54	60	52	54	53	56	53	28	65	58	59	59	61	59	34	71	64	65	64	66	65	41
14	600	283	0.012	2.96	12	5	5	13	22	-1	—	19	13	12	19	27	6	—	26	22	19	25	32	14	—
	1375	649	0.063	15.55	37	29	31	35	41	28	—	44	37	38	40	46	35	—	51	46	45	46	51	43	21
	2125	1003	0.149	37.15	50	41	45	46	50	43	20	57	50	52	52	55	50	26	65	59	59	57	61	58	34
	2900	1369	0.278	69.19	60	50	55	54	57	54	29	67	59	62	60	62	61	37	74	68	69	65	68	68	45
16	800	378	0.012	3.03	28	14	16	15	23	18	—	33	20	22	20	28	24	—	37	26	28	26	33	29	—
	1775	838	0.060	14.90	46	36	37	35	41	38	—	51	42	43	41	46	43	—	56	48	49	47	51	49	23
	2725	1286	0.141	35.13	56	48	48	47	51	48	22	61	54	54	52	56	54	29	66	59	60	58	61	59	35
	3700	1746	0.260	64.76	64	56	56	54	58	56	31	68	62	62	60	63	61	38	73	68	68	66	68	67	44

LEGEND

- AHRI** — Air Conditioning, Heating and Refrigeration Institute
- Cfm** — Air Volume (cubic feet per minute)
- L_p** — Room Sound Pressure
- L_w** — Sound Power
- Min ΔP_s** — Minimum Static Pressure Required to Achieve Rated Airflow
- NC** — AHRI 885-98 Test Conditions
- Ps** — Static Pressure
- — Indicates an NC level less than 20
- — Sound Power Noise Criteria

NOTES:

1. ΔPs is the difference in static pressure from inlet to discharge.
2. Sound power levels are in decibels, re 10⁻¹² watts.
3. Radiated sound power is the noise transmitted through the casing walls.
4. All sound data are based upon test conducted in accordance with AHRI Standard 880-98.
5. NC application data based on AHRI 885-98 (2002 Addendum — Appendix E).



35J UNIT DISCHARGE SOUND POWER

35J UNIT SIZE	FLOW RATE		MIN ΔPs		0.5 in. wg ΔPs							1.0 in. wg ΔPs							2.0 in. wg ΔPs						
					Octave Band Sound Power, L _w							L _p	Octave Band Sound Power, L _w							L _p	Octave Band Sound Power, L _w				
	Cfm	L/s	in. wg	pa	2	3	4	5	6	7	NC	2	3	4	5	6	7	NC	2	3	4	5	6	7	NC
04	50	24	0.011	2.81	37	25	27	26	26	19	—	41	29	31	29	30	23	—	45	33	35	32	33	27	—
	110	52	0.055	13.59	47	37	37	37	37	28	—	51	41	41	40	41	32	—	55	45	45	43	44	36	—
	170	80	0.131	32.53	52	44	43	43	43	33	—	56	48	47	46	47	37	—	61	52	51	50	50	41	—
	230	109	0.239	59.50	56	49	47	47	48	37	—	60	53	51	50	51	41	—	64	57	55	54	54	45	21
05	75	35	0.011	2.82	37	25	28	28	28	22	—	42	30	33	32	31	27	—	47	35	37	35	35	31	—
	170	80	0.058	14.46	48	39	40	40	40	32	—	53	44	44	43	43	37	—	58	49	48	46	47	41	—
	265	125	0.141	35.21	54	46	46	46	46	38	—	59	51	50	49	50	42	—	64	56	54	53	53	46	20
	360	170	0.261	64.93	58	51	50	50	51	42	—	63	56	54	54	54	46	—	68	61	59	57	57	50	22
06	100	47	0.009	2.29	37	26	30	30	30	26	—	42	31	35	33	33	30	—	47	36	39	37	37	34	—
	240	113	0.053	13.19	50	41	42	42	42	36	—	55	46	46	45	46	40	—	60	51	50	49	49	44	—
	380	179	0.133	33.12	57	49	48	48	49	42	—	61	54	53	52	52	46	—	66	59	57	55	56	50	—
	520	245	0.249	61.98	61	54	53	53	53	45	—	66	59	57	56	56	50	—	71	64	61	60	60	54	25
07	150	71	0.012	2.88	41	29	33	34	33	29	—	46	34	37	37	37	33	—	50	39	42	40	40	38	—
	330	156	0.056	13.93	52	43	44	45	44	39	—	57	48	49	48	48	43	—	62	53	53	51	51	48	—
	525	248	0.142	35.26	59	51	51	51	51	45	—	64	56	55	54	54	49	—	68	61	60	58	58	53	22
	710	335	0.259	64.50	63	57	55	55	55	49	—	68	61	60	59	59	53	—	73	66	64	62	62	57	25
08	200	94	0.012	3.01	43	33	37	36	36	32	—	47	38	41	39	39	36	—	52	42	46	43	42	41	—
	440	208	0.059	14.59	54	46	47	47	47	42	—	58	51	51	50	50	46	—	63	55	55	53	54	50	—
	675	319	0.138	34.33	60	53	52	52	53	47	—	64	58	57	56	56	52	21	69	63	61	59	60	56	27
	925	437	0.259	64.47	64	58	56	57	57	51	—	69	63	61	60	61	56	20	74	68	65	64	64	60	26
09	250	118	0.012	2.97	43	35	38	37	37	35	—	48	40	42	40	40	39	—	53	44	47	44	44	43	—
	550	260	0.058	14.39	54	47	48	48	48	45	—	59	52	53	51	51	49	—	64	57	57	55	55	53	—
	875	413	0.146	36.42	61	55	54	55	55	50	—	66	60	59	58	58	54	—	71	65	63	61	61	59	23
	1200	566	0.275	68.51	66	60	58	59	59	54	—	71	65	63	62	62	58	23	76	70	67	66	66	63	29
10	300	142	0.011	2.75	44	35	38	38	38	36	—	49	40	42	41	42	41	—	54	45	47	45	45	45	—
	675	319	0.056	13.94	56	48	49	49	50	46	—	61	53	54	53	53	51	—	66	58	58	56	57	55	—
	1075	507	0.142	35.37	63	56	56	56	56	52	—	68	61	60	59	60	56	20	73	66	64	63	63	61	25
	1450	684	0.259	64.35	67	61	60	60	61	56	—	72	66	64	64	64	60	24	77	71	68	67	67	64	31
12	450	212	0.012	3.01	47	39	41	41	41	42	—	52	44	45	45	44	46	—	57	49	50	48	48	50	—
	1000	472	0.060	14.86	59	52	52	52	52	51	—	63	57	57	56	56	55	—	68	62	61	59	59	59	23
	1550	731	0.143	35.71	65	59	58	59	59	56	20	70	64	63	62	62	60	24	74	69	67	65	66	64	28
	2100	991	0.263	65.54	69	64	63	63	63	60	24	74	69	67	66	67	64	28	79	73	71	70	70	68	33
14	600	283	0.012	2.96	48	39	43	43	42	43	—	53	44	47	46	46	47	—	58	49	52	50	49	51	—
	1375	649	0.063	15.55	60	53	55	55	55	54	—	65	58	59	58	58	58	22	70	63	63	62	61	62	26
	2125	1003	0.149	37.15	67	61	61	61	61	59	23	72	66	65	64	64	64	27	77	71	69	68	68	68	32
	2900	1369	0.278	69.19	71	66	65	65	65	63	27	76	71	69	69	69	68	31	81	76	74	72	72	72	36
16	800	378	0.012	3.03	51	42	45	45	45	46	—	56	47	49	48	49	50	—	61	52	53	52	52	54	—
	1775	838	0.060	14.90	62	56	56	56	57	56	20	67	61	60	60	60	60	24	72	65	65	63	63	65	29
	2725	1286	0.141	35.13	68	63	62	62	63	62	26	73	68	66	66	66	66	30	78	72	71	69	69	70	34
	3700	1746	0.260	64.76	72	68	67	67	67	66	29	77	73	71	70	71	70	34	82	78	75	74	74	74	38

LEGEND

- AHRI** — Air Conditioning, Heating and Refrigeration Institute
- Cfm** — Air Volume (cubic feet per minute)
- L_p** — Room Sound Pressure
- L_w** — Sound Power
- Min ΔP_s** — Minimum Static Pressure Required to Achieve Rated Airflow
- NC** — AHRI 885-98 Test Conditions
- Ps** — Static Pressure
- — Indicates an NC level less than 20
- — Sound Power Noise Criteria

NOTES:

1. ΔPs is the difference in static pressure from inlet to discharge.
2. Sound power levels are in decibels, re 10⁻¹² watts.
3. End discharge sound power is the noise emitted from the unit discharge into the duct.
4. All sound data are based upon test conducted in accordance with AHRI Standard 880-98.
5. NC application data based on AHRI 885-98 (2002 Addendum — Appendix E).



Several factors should be considered when selecting single-duct units. These include:

Airflow range

Carrier single-duct units include a linear averaging flow probe in the unit inlet to allow pressure-independent control of airflow on the basis of a control signal. The flow range is limited by the sensitivity of the controller employed, the inlet duct conditions, and the size of the selected unit.

In most cases, inlet duct minimum airflow of less than 350 fpm should be avoided to prevent erratic control. A minimum flow less than 350 fpm results in pressure signals less than 0.01 in. wg, which cannot be resolved reliably by most control systems.

Maximum inlet flow limits are typically restricted to less than 2500 fpm by duct pressure loss limitations, although acoustical limits may also limit selection above this range. The 35J units will operate well up to 3000 fpm inlet velocity, but with increased pressure drop through the supply duct and high noise levels.

System pressure

Control of duct pressures is the most effective means of ensuring low noise levels, accurate flow control, and minimum energy use. The use of various fan-tracking techniques can ensure optimum system efficiency and operation. Response times of the fan tracking system should be adjustable in order to prevent system oscillations between the pressure independent controllers and the fan system.

Minimum inlet static pressure shown in the Basic Pressure Data table on page 8 is the pressure required by a given size box at a specified airflow with the unit damper wide open. This pressure was measured by tests conducted in accordance with AHRI (Air Conditioning and Refrigeration Institute) Standard 880-98, using 3 ft of discharge duct of the same size as the unit plenum. The pressure shown is for the unit only or for unit plus hot water coil or electric heat coil. To determine the total static pressure loss in the distribution system, the minimum inlet static pressure must be added to the duct pressure drop (both upstream and downstream of the 35J unit) and the outlet pressure drop.

Acoustics

The primary determinant in the acoustics of a terminal is the inlet, or duct, static pressure. While velocity (flow rate) is also a factor, significant reductions in sound can be real-

ized by reducing duct pressures in the branch duct supplying the unit.

Lined duct downstream of the unit is very effective in reducing discharge noise levels. Where no duct lining is employed between the unit and the room diffusers, a noisy system is possible. Reducing inlet pressure drop will help, provided the techniques used to reduce local duct pressure levels do not increase noise levels in the duct that will be carried into the space.

Radiated sound is seldom a problem with single duct terminals. Flexible duct at the inlet however, can transmit airborne sound levels into the plenum space, where they add to the radiated sound component.

Acoustic performance data

Acoustic performance data shown for 35 Series is based on tests conducted in accordance with AHRI Standard 880-98. Data is presented as sound power for the units indicated. When the attenuator, octopus, or electric reheat version is ordered, a long unit will be shipped. The added length of this unit reduces sound power in a similar manner as 3 ft of lined duct, producing an effective 3 NC (noise criteria level) reduction in room sound levels in most cases.

Application sound levels are provided as NC levels. These are determined by applying factors provided in AHRI Standard 885-98. Lined duct, ceiling effect, and room attenuation are typical for many office spaces. These assumptions, for discharge (airborne) sound, also include a typical end reflection effect. Alternate effects can be examined by using the Carrier Air Terminal Builder program or AHRI Standard 885-98, available at no charge from the AHRI Web page (www.ahri.org).

If both the diffuser and the terminal are selected at the same delivered sound power level, the discharge (airborne) sound levels should be combined, by octave band, with the sound power generated by the selected diffuser when predicting sound levels in the space. In many cases, diffusers generate higher frequency sound than the terminal, and the two power levels combine without raising the room NC level. Each application of unit and diffuser must be examined individually to verify that the net NC does not increase. (Equal sound power levels, when added, increase the sound level by 3 dB.)

NOTE: Refer to Carrier publication: **HVAC Acoustical Application Guidelines** (catalog no. 811-449) for additional information.

Application data (cont)



35J UNIT — APPLICATION ASSUMPTIONS (dB)

AHRI 885-98	OCTAVE BANDS					
DISCHARGE <300 cfm	2	3	4	5	6	7
Env Effect	2	1	0	0	0	0
Duct Lining, 5 ft, 8 x 8 x 1 in.	2	6	12	25	29	18
End Reflection	9	5	2	0	0	0
Power Division (0 outlets)	0	0	0	0	0	0
5 ft, 8 in. Flex Duct	6	10	18	20	21	12
Space Effect	5	6	7	8	9	10
Total Attenuation	24	28	39	53	59	40

AHRI 885-98	OCTAVE BANDS					
DISCHARGE 300-700 cfm	2	3	4	5	6	7
Env Effect	2	1	0	0	0	0
Duct Lining, 5 ft, 12 x 12 x 1 in.	2	4	10	20	20	14
10 in. End Reflection	9	5	1	0	0	0
Power Division (2 outlets)	3	3	3	3	3	3
5 ft, 8 in. Flex Duct	6	10	18	20	21	12
Space Effect	5	6	7	8	9	10
Total Attenuation	27	29	40	51	53	39

AHRI 885-98	OCTAVE BANDS					
DISCHARGE >700 cfm	2	3	4	5	6	7
Env Effect	2	1	0	0	0	0
Duct Lining, 5 ft, 15 x 15 x 1 in.	2	3	9	18	17	12
End Reflection	9	5	2	0	0	0
Power Division (3 outlets)	5	5	5	5	5	5
5 ft, 8 in. Flex Duct	6	10	18	20	21	12
Space Effect	5	6	7	8	9	10
Total Attenuation	29	30	41	51	52	39

AHRI 885-98	OCTAVE BANDS					
RADIATED	2	3	4	5	6	7
Mineral Tile Space/Ceiling Effect	16	18	20	26	31	36
Environ. Effect	2	1	0	0	0	0
Total Attenuation	18	19	20	26	31	36

Notes for Sound Data Tables:

Air Conditioning and Refrigeration Institute (AHRI) and ASHRAE (American Society of Heating, Refrigeration and Air Conditioning Engineers) provide guidance in both measuring sound power levels (per AHRI 880-98), and in estimating the resultant room sound pressure, typically shown as an NC level (per AHRI 885-98 — 2002 addendum — Appendix E). American Society of Heating, Refrigeration and Air Conditioning Engineers (ASHRAE) handbooks provide detailed acoustical guidance. Air Conditioning and Refrigeration Institute (AHRI) Standard 885 is an application standard which provides tables and equations for determining acoustical deduction based on the ASHRAE guides, as well as additional information provided by manufacturers.

All sound data shown by octave bands is raw data without any corrections for room absorption or duct attenuation. This sound power data is tested in accordance with AHRI Standard 880-98.

Noise criteria level values reflect a more accurate sound level estimate for typical office spaces or other applications. These NC levels are calculated based on procedures from AHRI Standard 885-98.

Single Duct VAV Retrofit Terminal Unit HVAC Guide Specifications

Size Range: **40 to 3700 Nominal cfm**

Carrier Model Numbers:

35JA (Analog Electronic Control)

35JC (ComfortID™, Variable Air Volume [VAV] Electronic Controls)

35JN (No Control or DDC [direct digital control] by Others)

35JP (Pneumatic Control)

35JV (3V™, Variable Volume and Temperature [VVT®] Electronic Controls)

Part 1 — General

1.01 SYSTEM DESCRIPTION:

Unit shall be a single duct, variable air volume retrofit terminal unit with control box for installation in a ceiling that permits access to the unit. Manufacturer shall supply unit(s) of the design, number, size and performance as shown on equipment drawings and schedules. Unit(s) are for use in conjunction with air distribution manifolds, distribution ductwork and ceiling-mounted diffusers.

1.02 QUALITY ASSURANCE:

- A. Insulation shall meet NFPA-90A requirements for flame spread and smoke generation and UL-181 requirements for anti-erosion, anti-corrosion, and anti-fungus properties.
- B. Sound power levels shall be tested in accordance with the requirements of AHRI 880-98.

1.03 DELIVERY AND STORAGE:

Units shall be stored and handled per manufacturer's recommendations.

Part 2 — Products

2.01 EQUIPMENT:

A. General:

Factory-assembled, externally powered, variable air volume control terminal. Unit shall be complete with a damper assembly, flow sensor, externally mounted volume controller, collars for duct connection and all required features. Control box shall be clearly marked with an identification label that lists such

information as nominal cfm, maximum and minimum factory-set airflow limits, coil type and coil hand, where applicable.

B. Unit Cabinet:

1. Constructed of 22-gage galvanized steel with round inlet and discharge collar. All primary air inlet and discharge collars shall accommodate standard flex duct sizes.
2. Optional 20-gage cabinet shall be constructed of 20-gage galvanized steel with round inlet and discharge collar. All primary air inlet and discharge collars shall accommodate standard flex duct sizes.
3. Optional stainless steel cabinet shall be constructed of stainless steel (type 304) with round inlet and discharge collar. All primary air inlet and discharge collars shall accommodate standard flex duct sizes.

C. Damper Assembly:

The control air damper assembly shall be constructed of heavy-gage steel with solid shaft rotating in Delrin® bearings. Damper shaft shall be marked on the end to indicate damper position. Damper blade shall incorporate a flexible gasket for tight airflow shutoff and operate over a full 90 degrees.

D. Controls:

1. Units shall have pressure-independent pneumatic, electronic, or communicating controls, as specified, capable of maintaining required airflow set points $\pm 5\%$ of the unit's capacity at any inlet pressure up to 6 in. wg. The controllers shall be capable of resetting between factory-set or field-set maximum and minimum (>350 fpm inlet duct velocity) set points to satisfy the room thermostat demand.
2. The unit shall be equipped with an amplified linear averaging flow probe located at 45 degrees across the inlet. The sensor will provide a differential pressure signal amplified to equal 3 times the velocity pressure with an accuracy of at least $\pm 10\%$ throughout the range of 350 to 2500 fpm inlet duct velocity, depending on the controller employed.

