



Single Duct Air Terminal Zone Controller VAV Fan Terminal Zone Controller Secondary Terminal Zone Controller

Application Data

Part Numbers 33ZCFANTRM, 33ZCVAVTRM, 33ZCSECTRM

CONTENTS

| | Page | | Page |
|---|-------|---|-------|
| GENERAL | 2 | Optimal Start Operation | 13 |
| Zone Controller Control Strategy | 2 | SYSTEM OVERRIDE MODES | 13 |
| PRODUCT DESCRIPTION | 3-8 | Pressurization | 13 |
| Single Duct Air Terminal Zone Controller (33ZCVAVTRM) | 3 | Evacuation | 13 |
| VAV Fan Terminal Zone Controller (33ZCFANTRM) | 4 | Night Time Free Cooling (NTFC) | 13 |
| Accessories | 5 | Morning Warm-Up | 13 |
| Sensor Information | 6 | SET POINT GROUPING | 13 |
| • SPACE TEMPERATURE SENSORS | | SPACE TEMPERATURE SHARING | 13,14 |
| • 33ZCT55SPT SENSOR | | SENSOR GROUPING | 14 |
| • 33ZCT56SPT SENSOR | | CALIBRATION | 14 |
| • REMOTE TIMED OVERRIDE | | CCN ALARMS | 14,15 |
| • SUPPLY AIR TEMPERATURE SENSOR (SAT) | | Space Temperature Limit Alarm | 14 |
| • PRIMARY AIR TEMPERATURE SENSOR (PAT) | | Linkage Failure (Failure to Communicate With Linkage Master) | 14 |
| INPUTS/OUTPUTS | 8,9 | Linkage Failure (Failure to Communicate with Air Source) | 15 |
| Single Duct Air Terminal Zone Controller (33ZCVAVTRM) | 8 | Supply Air Temperature Sensor Failure | 15 |
| • ANALOG INPUTS | | Primary Air Temperature Sensor Failure | 15 |
| • TRIAC OUTPUTS | | Pressure Sensor Low Airflow Pressure Alarm | 15 |
| VAV Fan Terminal Zone Controller (33ZCFANTRM) | 9 | Pressure Sensor High Velocity Pressure Alarm | 15 |
| • ANALOG INPUTS | | Relative Humidity Sensor Alarm | 15 |
| • TRIAC OUTPUTS | | IAQ Sensor Alarm | 15 |
| • RELAY OUTPUTS | | Failure to Zero Calibrate Pressure Transducer | 15 |
| NETWORK SYSTEM DESIGN INFORMATION | 10 | Damper Position and Actuator Installation | 15 |
| Design Considerations | 10 | CCN USER INTERFACE | 15,16 |
| Network Design | 10 | APPLICATION | 17-36 |
| • COMMUNICATION LIMITATIONS | | General | 17 |
| • COMMUNICATION ADDRESSING | | General Heating Information | 17 |
| • OCCUPANCY SCHEDULING | | Disabling Reheat From CCN | 18 |
| Network Addressing | 10 | Non-Ducted Heat Control (Single or Staged Heat) | 18 |
| Zone Controller User Interfaces | 10 | Modulating Baseboard Heating | 18 |
| LINKAGE | 11,12 | Ducted Heat Control (Staged or Modulating Device) | 18 |
| CCN Air Sources or Air Sources Which Support Linkage | 11 | Modulating Hot Water/Steam Valve CV | 18 |
| • AIR TERMINAL MODES | | VAV Central Heating | 18 |
| Non-CCN Air Sources or Air Sources That Do Not Support Linkage | 11 | VAV Central Heating with Ducted Zone Heat | 19 |
| • OFF MODE | | Morning Warm-Up | 19 |
| • HEAT MODE | | Damper Override | 19 |
| • COOL MODE | | Nighttime Free Cooling | 19 |
| • FREE COOLING MODE | | Single Duct Terminal Applications | 19 |
| Communications Alarms with Linkage | 12 | • COOLING | |
| OCCUPANCY (LOCAL/GLOBAL) | 12,13 | • HEATING | |
| Overview | 12 | • COOLING ONLY | |
| Local Occupancy | 12 | • STAGED ELECTRIC HEAT | |
| Global Occupancy | 12 | • HOT WATER OR STEAM HEAT | |
| Remote Occupancy Contact | 13 | 33ZCFANTRM VAV Zone Controller Information .. | 23 |
| Occupancy Override | 13 | | |
| Manual Occupancy Override Function | 13 | | |
| Occupancy Table Format | 13 | | |

Manufacturer reserves the right to discontinue, or change at any time, specifications or designs without notice and without incurring obligations.

CONTENTS (cont)

| | Page |
|--|-------|
| Series Fan Terminal Applications | 23 |
| • COOLING | |
| • HEATING | |
| • COOLING WITH FAN | |
| • STAGED ELECTRIC HEAT | |
| • HOT WATER OR STEAM HEAT | |
| Parallel Fan Terminal Applications | 25 |
| • COOLING | |
| • HEATING | |
| • COOLING ONLY | |
| • STAGED ELECTRIC HEAT | |
| • HOT WATER HEAT | |
| Static Pressure Reset | 29 |
| • OVERVIEW | |
| • OPERATION | |
| Indoor Air Quality (IAQ) Control | 29 |
| Secondary Zone Controller (33ZCSECTRM) | 29 |
| Zone Pressure Control (Terminal Tracking) | 33 |
| • GENERAL | |
| • LIMITATIONS | |
| • TERMINAL TRACKING | |
| Dual Duct Terminal Applications | 34 |
| • CONSTANT VOLUME DUAL DUCT APPLICATIONS | |
| • VARIABLE VOLUME DUAL DUCT APPLICATIONS | |
| Dehumidification Control Function | 36 |
| GUIDE SPECIFICATIONS | 37-43 |

GENERAL

The zone controller is a single duct or fan powered, Variable Air Volume (VAV) terminal control with a factory-integrated controller and actuator. The zone controller maintains precise temperature control in the space by operating the terminal fan (if supplied), regulating the flow of conditioned air into the space, and controlling the auxiliary heating (if applicable). Buildings with diverse loading conditions can be supported by controlling reheat or supplemental heat.

The Single Duct Air Terminal Zone Controller (33ZCVAVTRM) provides dedicated control functions for single duct terminals with modulating heat or up to 2 stages of heat.

The VAV Fan Terminal Zone Controller (33ZCFANTRM) provides dedicated control functions for series fan or parallel fan powered terminals, single duct terminals with up to 3 stages of heat or modulating heat. The VAV Fan Terminal zone controller can also be used as a primary controller for dual duct or zone pressure control applications.

When the VAV Fan Terminal Zone Controller is used in conjunction with a secondary terminal and the 33ZCSECTRM secondary terminal zone controller, zone pressurization applications can be supported. Also, when the VAV Fan Terminal Zone Controller is used in conjunction with a secondary terminal and the 33ZCSECTRM secondary terminal, constant volume dual duct applications can be supported.

Carrier's Linkage system is an integrated combination of Carrier Comfort Network (CCN) controllers for use with Single Duct air terminals and Fan Powered terminals. The Single Duct and Fan powered terminal zone controllers are part of the Carrier ComfortID system.

Rooftop units and air handlers feature factory-installed PIC controllers that are directly compatible with the system. They do not require any special hardware to be compatible with the Carrier linkage system. Consult your local CCN representative for the complete list of compatible air handlers and rooftop

units. The Comfort System Air Manager (CSAM) or the CC6400 supports linkage for non-Carrier air handlers.

Zone Controller Control Strategy — The primary goal of the zone controller control strategy is to satisfy the temperature and air quality requirements of each zone in a timely and energy efficient manner. Secondary control strategies include zone pressure control, high humidity control, and demand controlled ventilation (DCV). The control provides pressure independent operation. To achieve these goals. The control strategy is broken into two parts: local zone control and system control.

The method for achieving local zone control is through the use of an electronic control in each air terminal (zone controller). The control functions of the zone controller are:

- temperature control of the space (cooling and optional heating)
- control of the space humidity (dehumidification)
- ventilation of the space
- fan control (for series and parallel type fan powered terminals)
- secondary damper control for dual duct terminals (constant volume airflow)
- zone pressurization (through the use of a return air terminal and secondary damper control)
- participation in the control of the entire air system

The method for achieving system control is to ensure that the air source operation is based on the demands of the occupied zones. In this concept, the air source produces only the amount of conditioned air (at a temperature and pressure) that is necessary to satisfy the current load requirements. It does this by varying either the amount of air it delivers, at a constant temperature, into the duct (maintaining duct pressure) or by varying the quality (temperature, humidity, quantity of outside air) of air it delivers into the duct. Its control parameters come from its own internal sources (configuration parameters, sensors) and from feedback information that it receives from the zones that it is supplying. The feedback allows the air source to adjust its static pressure set point, supply air temperature set point, quantity of outdoor air, and occupancy schedule, which allows it to run in the most efficient manner.

In addition the air source shall provide its operating mode to the zone controllers to aid in the control of the air terminals. Specifically the system shall utilize the following functions in its control of the air source:

- Variable Air Volume (VAV) — VAV involves adjusting the volume of air moving in the supply duct to maintain the static pressure in the supply air duct at desired supply air pressure set point. This adjustment will be in response to changing airflow requirements of the zones serviced by the air source.
- Occupancy — Determining when the air source is operating based on the occupancy status of the zones. Override of zone occupancy is also available from space temperature sensor.
- Mode determination — Determining the air source operating mode based on the demands of the zones.
- Temperature Set Point Reset — Adjusting the supply air temperature set point of the air source based on the current cooling demands of the zones
- Pressure Set Point Reset — Adjusting the supply air pressure set point of the air source based on the current airflow demands of the zones.

The VAV control is an inherent part of the air source control that works outside the scope of the zoning system. It is included in this document to provide a complete picture of the air source operation. The remaining functions are integrated into the zoning system strategy.

PRODUCT DESCRIPTION

The Air Terminal Controller provides dedicated control functions for a single air terminal and system support functions for a network of like controllers.

Single Duct Air Terminal Zone Controller (33ZCVAVTRM) — The Single Duct Air Terminal Zone Controller provides dedicated control functions for single duct terminals with modulating heat or up to 2 stages of heat. The zone controller is part of the Carrier ComfortID system.

The 33ZCVAVTRM Single Duct Air Terminal Zone Controller provides the following features and benefits:

- capable of demand control ventilation
- provides Pressure Independent (VAV) control
- uses Proportional Integral Derivative (PID) control
- mounts directly onto VAV box damper shaft
- for terminals up to 9000 cfm or 3.4 sq. ft inlet (primary air)
- auxiliary heating control of modulating (floating) hot water, single or two-position hot water, single or two-stage electric, or zone perimeter heat
- quick and easy commissioning and balancing process
- automatic self calibration of airflow transducer
- capable of stand-alone operation
- actuator preassembled to housing
- capable of demand controlled ventilation support with field-installed IAQ (Indoor Air Quality) sensor
- easy access to airflow sensor pneumatic connections
- Carrier Comfort Network (CCN) compatible
- capable of high-speed 38.4 kilobaud communications network operation
- 128 controller maximum system (must be located on same CCN bus segment)
- capable of zone humidity control (dehumidification) with field-installed humidity sensor
- Carrier Linkage System capability
- global set point and occupancy scheduling
- capable of local set point adjustment with field-installed temperature sensor (with temperature offset)
- both controller housing and actuator are UL94-5V plenum rated

The zone controller is a single duct, variable air volume (VAV) terminal control with a factory-integrated actuator. The zone controller maintains precise temperature control in the space by regulating the flow of conditioned air into the space.

Buildings with diverse loading conditions can utilize reheat or supplemental heating control. The zone controller can support two position hot water, modulating hot water, 2-stage electric, or perimeter heat.

The zone controller provides additional control features such as Occupied/Unoccupied scheduling initialized via the network. The zone controller offers override invoked from a wall sensor during unoccupied hours from 1 to 1440 minutes in 1-minute increments. Optional Indoor Air Quality (IAQ) or relative humidity monitoring and control are also available. The Occupied Override function supports Carrier's Tenant Billing if the override time is set to values of 1, 2, 3, or 4 hours (60, 120, 180, or 240 minutes).

The zone controller control assembly contains an integral VAV actuator assembly that is field mounted to the VAV terminal damper shaft, similar to the mounting of a standard actuator. The actuator is rated at 35 lb.-in. (3.95 N-m) torque, a 90-degree stroke, and provides a 90-second nominal time at 60 Hz. The actuator is suitable for mounting onto a 3/8-in. (9.5 mm) square or round damper shaft, or onto a 1/2-in. (13 mm) round damper shaft. The minimum damper shaft

length is 1 3/4-in. (45 mm). The zone controller is designed for vertical or horizontal mounting.

The zone controller is provided with removable connectors for power and communications. The zone controller has non-removable screw type connectors for inputs. The removable connectors are designed so that they can be inserted one way so as to prevent installation errors. The zone controller also provides an RJ-11 modular phone jack for the Network Service tool connection to the module via the Carrier Comfort Network (CCN) communications.

An optional Conduit Box Cover (Part Number 33ZCCONBOX) allows field wiring connection via conduit. The conduit box is designed to accept two 1/2-in. (13 mm) EMT conduits.

The 33ZCVAVTRM is designed to allow a service person or building owner to configure and operate the unit through the CCN user interfaces. A user interface is not required for day-to-day operation. All maintenance, configuration, setup, and diagnostic information is available through the Level II communications port to allow data access by an attached computer running Network Service Tool, ComfortVIEW™, or ComfortWORKS® software.

→ **WIRING CONNECTIONS** — Field wiring is 18 to 22 AWG (American Wire Gauge). The zone controller is a NEC (National Electrical Code) Class 2 rated device.

INPUTS

- space temperature sensor
- primary air damper position (factory-installed)
- airflow sensor (factory installed)
- remote wall sensor set point adjustment
- optional supply temperature sensor (required for ducted heat)
- optional primary air temperature sensor (required for systems which do not utilize a linkage compatible air source system)
- optional IAQ sensor or relative humidity sensor
- optional remote occupancy contact

OUTPUTS

- internally factory-wired damper actuator
- heating (ducted or non-ducted)
 - modulating (floating) heat
 - up to 2 stages of electric heat (if 3 stages are required, the 33ZCFANTRM should be used)
 - two position heat

POWER SUPPLY

The 33ZCVAVTRM zone controller requires a 24 VAC ± 10% at 40 VA (50/60 Hz) power source.

POWER CONSUMPTION — The power requirement sizing allows for accessory water valves or heat contactors. Water valves are limited to 15 VA on both two-position and modulating hot water. The heat contactors are limited to 10 VA (holding) each.

ACCURACY — Terminal airflow (nominal cfm) is rated at 1-in. wg (249 kPa) measured velocity pressure. The zone controller is capable of controlling to as low as 10% or as high as 125% of nominal airflow with an accuracy of ± 3% (nominal) at any point within the range.

HARDWARE (MEMORY)

FLASH EPROM

DIFFERENTIAL PRESSURE RANGE

0 to 2.0 in. wg (0 to 498 kPa) maximum for the onboard flow sensor.

SPECIFIED SENSING TEMPERATURE RANGE — The zone controller space temperature, supply air temperature, and primary air temperature sensing range is -40 to 245 F (-40 to 118 C). The zone controller has an allowable control set point range from 40 to 90 F (4 to 32 C) for heating and 45 to 99 F (7 to 37 C) for cooling.

COMMUNICATIONS — The number of controllers is limited to 128 zones maximum, with a limit of 8 systems (Linkage Coordinator configured for at least 2 zones). Bus length may not exceed 4000 ft (1219 m), with no more than 60 devices on any 1000 ft (305 m) section. Optically isolated RS-485 repeaters are required every 1000 ft (305 m).

At 19,200 and 38,400 baud, the number of controllers is limited to 128 maximum, with no limit on the number of Linkage Coordinators.

ENVIRONMENTAL RATINGS

Operating Temperature: 32 to 140 F (0° to 60 C) at 10 to 90% RH (non-condensing)

Shipping Temperature: -40 to 185 F (-40 to 85 C) at 0 to 90% RH (non-condensing)

VIBRATION

Performance vibration:

- 0.014-in. (0.356 mm) Peak-to-Peak displacement measured at 5 to 31 Hz
- 0.75 G measured at 31 to 300 Hz

CORROSION

Office environment. Indoor use only.

VAV Fan Terminal Zone Controller (33ZCFANTRM)

— The VAV Fan Terminal Zone Controller provides dedicated control functions for series fan or parallel fan powered terminals, single duct terminals with 3 stages of heat, or as a primary controller for dual duct or zone pressurization applications. The zone controller is part of the Carrier ComfortID System.

The 33ZCFANTRM VAV Fan Terminal Zone Controller provides the following features and benefits:

- provides Pressure Independent (VAV) control
- uses Proportional Integral Derivative (PID) control
- mounts directly onto VAV box damper shaft
- terminal fan control
- for terminals up to 9000 cfm or 3.4 sq. ft inlet (primary air)
- auxiliary heating control of modulating (floating) hot water, two-position hot water; single, two, or three stage electric; or zone perimeter heat
- quick and easy commissioning and balancing process
- automatic self calibration of airflow transducer
- capable of stand-alone operation
- actuator preassembled to housing
- capable of demand controlled ventilation
- capable of individual zone pressure control for individual supply and exhaust control in conjunction with secondary terminal controller (required)
- easy access to airflow sensor pneumatic connections
- Carrier Comfort Network (CCN) protocol compatible
- capable of high-speed 38.4 kilobaud communications network operation
- 128 controller maximum system (must be located on same CCN bus segment)
- capable of zone humidity control (dehumidification)
- Carrier Linkage System compatibility
- global set point and occupancy scheduling
- capable of local set point adjustment with field-installed temperature sensor (with temperature offset)
- both controller housing and actuator are UL94-5V plenum rated

The zone controller is a single duct or fan powered, variable air volume (VAV) terminal control with a factory-integrated actuator. The zone controller maintains precise temperature control in the space by operating the terminal fan and regulating the flow of conditioned air into the space.

Buildings with diverse loading conditions can be supported by controlling reheat, ducted heat, or non-ducted supplemental heat. The zone controller can support two-position hot water, modulating hot water, or up to 3-stage electric heat.

With the addition of a secondary exhaust or return air terminal and the 33ZCSECTRM controller, zone pressurization applications can be supported.

Supply and exhaust airflow control is provided on an individual zone basis in order to maintain the desired zone pressure.

The 33ZCSECTRM in conjunction with the fan terminal zone controller are used to provide control for constant volume dual duct applications.

When linked to a Carrier Linkage System, the zone controller provides numerous features and benefits such as weighted average demand for system operation, intelligent supply air temperature reset, set point averaging, global set point schedule, and occupancy scheduling. Duct static pressure reset for the air source is provided, based on terminal requirements.

The zone controller provides additional control features such as Occupied/Unoccupied scheduling initialized via the network. The zone controller offers override invoked from a wall sensor during unoccupied hours from 1 to 1440 minutes in 1-minute increments. Optional indoor air quality (IAQ) or relative humidity monitoring and control are also available.

The zone controller assembly contains an integral VAV actuator that is field mounted to the VAV terminal damper shaft, similar to the mounting of a standard actuator. The actuator is rated at 35 lb-in. (3.95 Nm) torque, a 90 degree stroke, and provides a 90-second nominal running time at 60 Hz. The actuator is suitable for mounting onto a 3/8-in. (9.5 mm) square or round damper shaft, or onto a 1/2-in. (13 mm) round damper shaft. The minimum damper shaft length is 1 3/4-in. (45 mm). The zone controller is designed for vertical or horizontal mounting.

The zone controller is provided with removable connectors for power and communications. The zone controller has non-removable screw type connectors for inputs. The removable connectors are designed so that they can be inserted one way so as to prevent installation errors. The zone controller also provides an RJ-11 modular phone jack for the Network Service tool connection to the module via the Carrier Comfort Network (CCN) communications.

An optional conduit box cover (Part Number 33ZCCONBOX) allows field wiring connection via conduit. The conduit box is designed to accept two 1/2-in. (13 mm) EMT conduits.

The 33ZCFANTRM is designed to allow a service person or building owner to configure and operate the unit through the CCN user interfaces. A user interface is not required for day-to-day operation. All maintenance, configuration, setup, and diagnostic information is available through the Level II communications port to allow data access by an attached computer running Network Service Tool, ComfortVIEW™, or ComfortWORKS® software.

WIRING CONNECTIONS — Field wiring is 18 to 22 AWG (American Wire Gage). The zone controller is a NEC (National Electrical Code) Class 2 rated device.

→ INPUTS

- space temperature sensor
- primary air damper position (factory-installed)
- airflow sensor (factory installed)
- field-installed remote wall sensor set point adjustment
- optional supply temperature sensor (required for ducted heat and supply air monitoring)
- optional primary air temperature sensor (one per system is required for systems which do not utilize a linkage compatible air source)
- optional IAQ sensor or relative humidity sensor
- optional secondary airflow (zone pressure or dual duct)
- optional remote occupancy contact

OUTPUTS

- internally factory-wired damper actuator
- heating (ducted or non-ducted)
 - modulating (floating) heat
 - up to 3 stages of electric heat
 - two-position heat
- fan start/stop
- secondary damper actuator

POWER SUPPLY — The 33ZCFANTRM requires a 24 VAC \pm 10% power source rated at 40 VA (50/60 Hz).

POWER CONSUMPTION — The power requirement sizing allows for accessory water valves and for the fan contactor. Water valves are limited to 8 VA on both two-position and modulating hot water. The fan contactor is limited to 11 VA (holding).

NOTE: If a water valve or fan contactor exceeds these limits, or external contactors are required for electric heat, then it is recommended a 60 VA transformer be used. The maximum rating for any output is 20 VA.

ACCURACY — Terminal airflow (nominal cfm) is rated at 1 in. wg (249 kPa) measured velocity pressure. The zone controller is capable of controlling to as low as 10% or as high as 125% of nominal airflow with an accuracy of \pm 3% (nominal) at any point within the range.

HARDWARE (MEMORY)

FLASH EPROM

DIFFERENTIAL PRESSURE RANGE

0 to 2.0 in. wg (0 to 498 kPa) maximum for the onboard flow sensor.

SPECIFIED SENSING TEMPERATURE RANGE — The zone controller space temperature, supply temperature, and primary air temperature sensing range is -40 to 245 F (-40 to 118 C). The zone controller has an allowable control set point range from 40 to 90 F (4 to 32 C) for heating and 45 to 99 F (7 to 37 C) for cooling.

COMMUNICATIONS — The number of controllers is limited to 128 zones maximum, with a limit of 8 systems (Linkage Coordinator configured for at least 2 zones). Bus length may not exceed 4000 ft (1219 m), with no more than 60 devices on any 1000 ft (305 m) section. Optically isolated RS-485 repeaters are required every 1000 ft (305 m).

At 19,200 and 38,400 baud, the number of controllers is limited to 128 maximum, with no limit on the number of Linkage Coordinators.

ENVIRONMENTAL RATINGS

Operating Temperature: 32 to 140 F (0° to 60 C) at 10 to 90% RH (non-condensing)

Shipping Temperature: -40 to 185 F (-40 to 85 C) at 0 to 90% RH (non-condensing)

VIBRATION

Performance vibration: 0.014-in. (0.356 mm) peak to peak displacement, 5 to 31 Hz; 0.75 G, 31 to 300 Hz

CORROSION

Office environment. Indoor use only.

APPROVALS

Listed under UL 916-PAZX, UL 873, and UL94-5V.

Accessories

SECONDARY TERMINAL CONTROLLER — The 33ZCSECTRM secondary terminal controller is required for dual duct or zone pressurization applications. For zone pressure control applications, the secondary terminal is used on a field-supplied, single zone exhaust damper.

CONDUIT BOX — The 33ZCCONBOX conduit box provides two conduit connections to the zone controller for installations requiring the use of conduit due to local electrical codes.

SUPPLY AIR TEMPERATURE SENSOR — The 33ZCSENSAT supply air temperature sensor is required for all ducted heating applications and stand-alone operation. The sensor is optional on cooling only applications and is used for supply air monitoring. The sensor has an operating range of -40 to 245 F (-40 to 118 C).

PRIMARY AIR TEMPERATURE SENSOR — The 33ZCSENPAT primary air temperature sensor is required on a linkage coordinator zone controller if the zone controller is not using a CCN linkage compatible air source. The sensor is used to monitor the equipment's supply air temperature. The temperature can be broadcast to the zone controllers which receive information from a linkage coordinator. The sensor has an operating range of -40 to 245 F (-40 to 118 C).

SPACE TEMPERATURE SENSOR WITH OVERRIDE BUTTON — The 33ZCT55SPT space temperature sensor with override button is required for all applications. The space temperature sensor monitors room temperature which is used by the zone controller to determine the amount of conditioned air that is allowed into the space.

SPACE TEMPERATURE SENSOR WITH OVERRIDE BUTTON AND SET POINT ADJUSTMENT — The 33ZCT56SPT space temperature sensor with override button and set point adjustment can be used in place of the 33ZCT55SPT space temperature sensor if local set point adjustment is required. A space temperature sensor is required for all applications. The space temperature sensor monitors room temperature which is used by the zone controller to determine the amount of conditioned air that is allowed into the space. The set point adjustment bar allows up to a $\pm 15^\circ$ F (8° C) temperature adjustment by the room occupant.

RELATIVE HUMIDITY SENSOR — The 33AMSENRRHS000 relative humidity sensor (indoor space) is required for zone humidity control (dehumidification).

NOTE: The relative humidity sensor and CO₂ sensor cannot be used on the same zone controller.

INDOOR AIR QUALITY SENSOR — Three different CO₂ sensors are available for optional demand control ventilation.

The 33ZCSENCO2 sensor is an indoor, wall mounted sensor with an LED (light-emitting diode) display.

The 33ZCT55CO2 sensor is an indoor, wall mounted sensor without display. The CO₂ sensor also includes a space temperature sensor with override button.

The 33ZCT56CO2 sensor is an indoor, wall mounted sensor without display. The CO₂ sensor also includes a space temperature sensor with override button and temperature offset.

NOTE: The relative humidity sensor and CO₂ sensor cannot be used on the same zone controller.

Sensor Information — Each zone controller requires a Carrier space temperature sensor that must be ordered separately. There are two space sensors available for this application the 33ZCT55SPT space temperature sensor with override button and the 33ZCT56SPT space temperature sensor with override button and set point adjustment.

SPACE TEMPERATURE SENSORS — The sensor housing is plastic ABS. The connections are screw terminals. The weight is 0.18 lbs. See Fig. 1 for sensor dimensions.

The 33ZCT56SPT space temperature sensor has a set point potentiometer that provides a set point input. The set point potentiometer range for each sensor can be adjusted from -15° to 15° F. Adjustment direction is indicated by COOL and WARM on the sensor cover.

The temperature sensor uses a 10K Ohm thermistor to sense ambient temperature. See Table 1 for resistance vs. temperature values for the thermistor.

The sensor is designed to be mounted in a vertical mounting position for proper operation.

33ZCT55SPT SENSOR — The 33ZCT55SPT space sensor is a basic space temperature sensor for use with the zone controller. It contains a thermistor to sense room temperature, override button for initiating a timed override, and an RJ11 jack for the connection of a CCN Network Service Tool. The sensor communications connection (RJ11) is concealed behind a removable cover. The sensor is field installed.

Space Temperature Sensor Wiring — In order to provide temperature sensing and override functions, the 33ZCT55SPT sensor must be connected to the zone controller using 20 AWG twisted pair cables. Pressing the timed override button on the 33ZCT55SPT sensor produces the required short-circuit signal. See Fig. 2 for internal schematic. The sensor has a screw terminal connector to facilitate wiring. All wiring from the zone controller to the sensor is field supplied.

Sensor terminals 1 and 2 are used for space temperature sensing. The space temperature sensor range is 32 to 120 F, with a nominal resistance of 10,000 ohms at 77 F.

33ZCT56SPT SENSOR — The 33ZCT56SPT space temperature sensor is field-installed. The 33ZCT56SPT is a wall mounted sensor capable of measuring the ambient temperature at its location, and is equipped with an override button. The override button (when pressed) provides a short across the internal thermistor. The sensor is also equipped with an RJ11

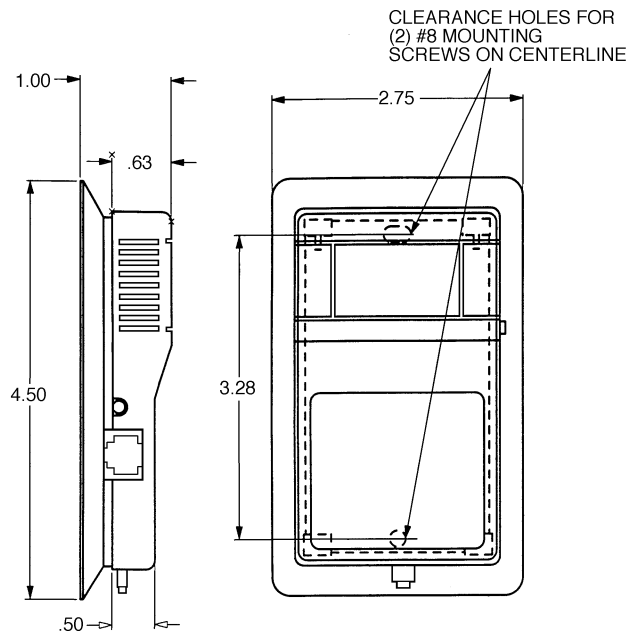

NOTE: Dimensions are in inches.

Fig. 1 — Space Temperature Sensor and Wall Mounted Humidity Sensor Dimensions

Service jack with a 6 pin termination block for CCN connection. The sensor is equipped with a 100K ohm (nominal) linear slide potentiometer.

Space Temperature Sensor Wiring — In order to provide temperature sensing and the override functions, the 33ZCT56SPT sensor must be connected to the zone controller using 3-conductor, 18 to 20 AWG cables. (The CCN communication cable may be used.) Pressing the timed override button on the 33ZCT56SPT sensor produces the required short-circuit signal. See Fig. 2 for internal schematic. The sensor has a screw terminal connector to facilitate wiring. All wiring from the zone controller to the sensor is field supplied. The sensor's thermistor has a range of 32 to 158 F with a nominal resistance of 10,000 ohms at 77 F.

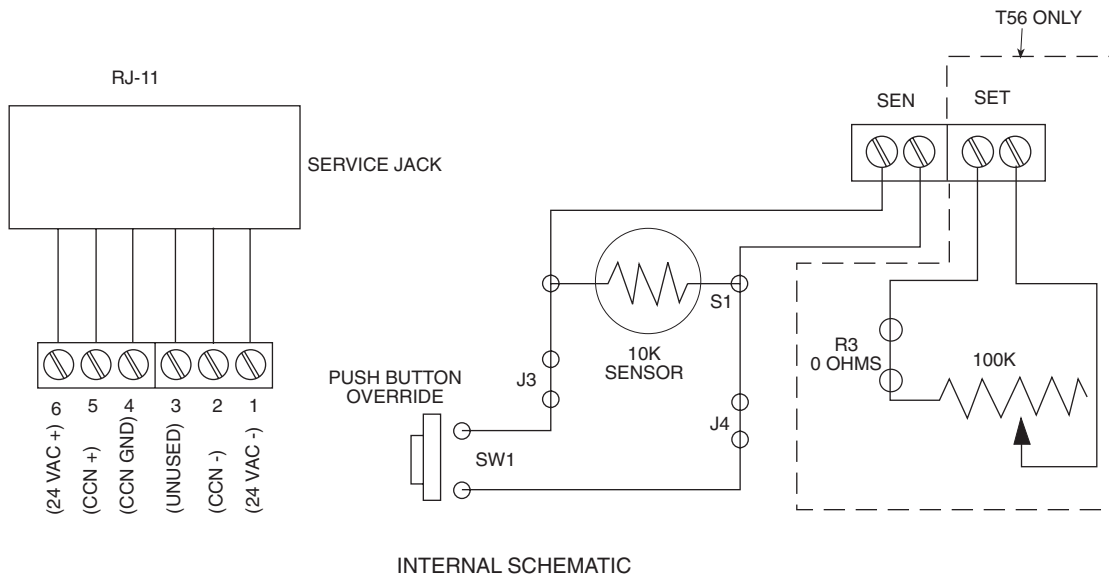

Fig. 2 — Temperature Sensor Internal Wiring

REMOTE TIMED OVERRIDE — Pressing the timed override button on the 33ZCT55SPT or 33ZCT56SPT sensors initiates a timed override. If the override is activated in a zone that is using a network time schedule, then the override will be reported to the global schedule. When using a global schedule, all the zones assigned to that schedule will go occupied when any of the space temperature override buttons are pressed by the user. For zones that require individual override, those zones are required to use a local schedule.

If the mode is currently unoccupied and the override function is activated, the mode will change to occupied for the period of time configured. The control will interpret a 1 to 10 second button press as a user initiated timed override command.

If the override button is held for less than 1 second or more than 10 seconds, the control will not enter override. If the override button is held for more than 60 seconds, a Space Temperature alarm will be generated.

SUPPLY AIR TEMPERATURE SENSOR (SAT) — The SAT sensor consists of a thermistor encased within a stainless steel probe. The probe is 6-in. nominal length. See Fig. 3. The sensor has 114-in. of unshielded, plenum-rated cable (2 conductors, 22 AWG). The range of the sensor is -40 to 185 F with a nominal resistance of 10,000 ohms at 77 F. The sensor measures temperature with an accuracy of ± 0.36 F (0.2 C) from 0° to 70 C. The sensor is supplied with a gasket and two self-drilling mounting screws.

PRIMARY AIR TEMPERATURE SENSOR (PAT) — The PAT sensor consists of a thermistor encased within a stainless steel housing with 5-in. of exposed length. See Fig. 4. The sensor has 2 teflon insulated, stranded conductors (24 AWG). The range of the sensor is -40 to 185 F with a nominal resistance of 10,000 ohms at 77 F. The sensor measures temperature with an accuracy of ± 0.36 F (0.2 C) from 0° to 70 C.

Table 1 — Thermistor Resistance vs Temperature Values for Space Temperature Sensor, Return-Air Temperature Sensor, and Supply-Air Temperature Sensor

| TEMP (C) | TEMP (F) | RESISTANCE (Ohms) |
|----------|----------|-------------------|
| -40 | -40 | 335,651 |
| -35 | -31 | 242,195 |
| -30 | -22 | 176,683 |
| -25 | -13 | 130,243 |
| -20 | -4 | 96,974 |
| -15 | 5 | 72,895 |
| -10 | 14 | 55,298 |
| -5 | 23 | 42,315 |
| 0 | 32 | 32,651 |
| 5 | 41 | 25,395 |
| 10 | 50 | 19,903 |
| 15 | 59 | 15,714 |
| 20 | 68 | 12,494 |
| 25 | 77 | 10,000 |
| 30 | 86 | 8,056 |
| 35 | 95 | 6,530 |
| 40 | 104 | 5,325 |
| 45 | 113 | 4,367 |
| 50 | 122 | 3,601 |
| 55 | 131 | 2,985 |
| 60 | 140 | 2,487 |
| 65 | 149 | 2,082 |
| 70 | 158 | 1,752 |

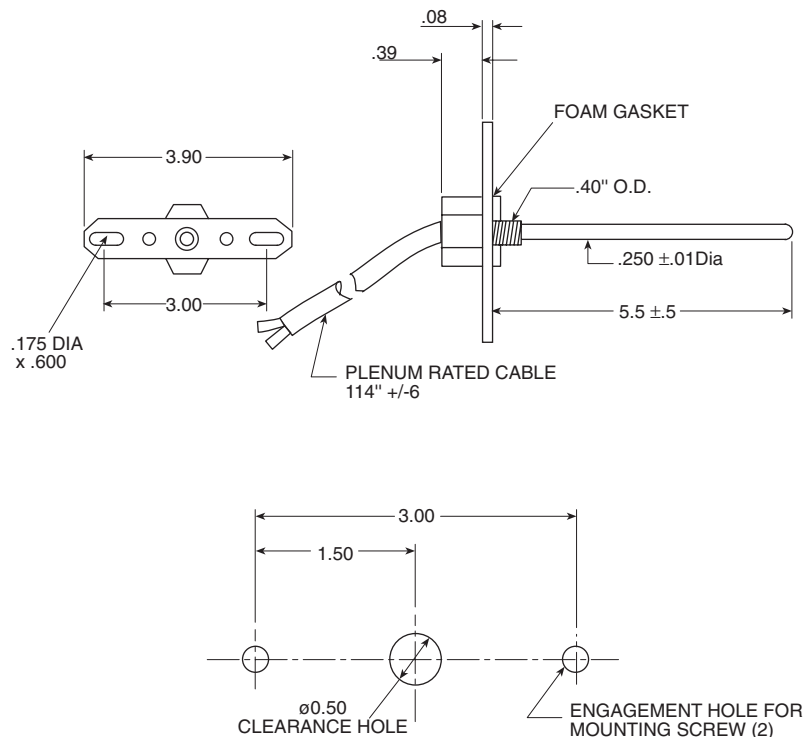

Fig. 3 — Supply Air Temperature Sensor Dimensions

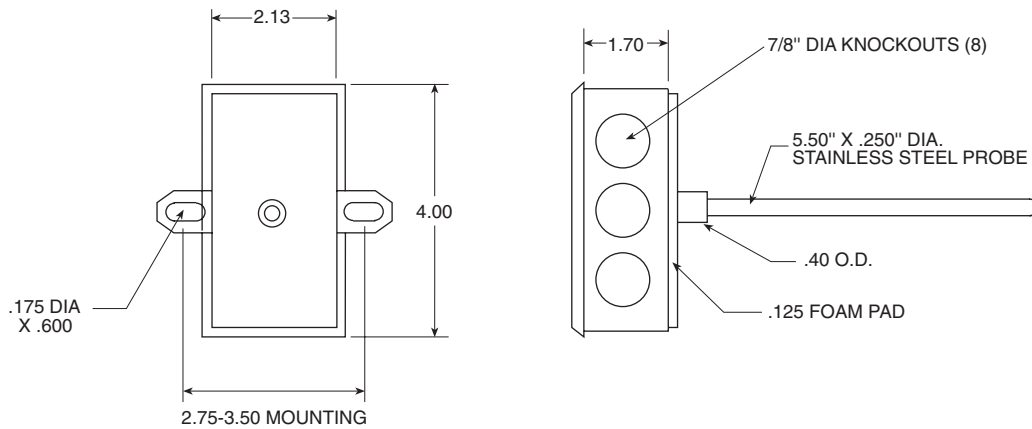

Fig. 4 — Primary Air Temperature Sensor Dimensions

INPUTS/OUTPUTS

Single Duct Air Terminal Zone Controller (33ZCVAVTRM) — The input and output channel assignments are shown in Table 2.

The zone controller provides seven analog inputs.

ANALOG INPUTS — The analog inputs consist of four thermistor type inputs and two 0 to 10 VDC inputs. The thermistor inputs conform to the nominal 10K thermistor values in Table 1.

TRIAC OUTPUTS — The zone controller has four 24-VAC triac outputs on the baseboard. These outputs are capable of switching 24 VAC at 1 Amp with a power factor of 0.8. Two triacs control the primary output damper. One drives the damper clockwise and the other counterclockwise. The two other triacs are dedicated to the control of either proportional or two position heat.

The specific output requirements for the air terminal applications are given in Table 3.

→ **Table 2 — Zone Controller Inputs (33ZCVAVTRM)**

| CHANNEL NAME | J4 TERMINATION | DESCRIPTION | DEVICE |
|--------------|--------------------------------|--|---|
| SPT | 14,12 (ground) | Space Temperature Sensor (33ZCT55SPT), field installed and wired | 10K Thermistor |
| SAT | 10,12 (ground) | Supply Air Temperature Sensor, required for heat, field installed and wired* | 10K Thermistor |
| SP_OFFST | 12 (ground), 8 | Set Point Offset Adjust, requires the use of field-installed 33ZCT56SPT space temperature sensor | 100K Potentiometer |
| PATEMP | 4, 6 (ground) | Primary Air Temperature Factory option field installed and wired† | 10K Thermistor |
| RH/IAQ** | 16 (24v), 15 (+), 13 (-) | RH/IAQ Sensor Factory option, field installed and wired | 0-10 VDC |
| DMPPOS | 9 (10v), 7 (W+), 5 (-) | Primary Damper Position Factory Supplied and wired with zone controller | 0-10 VDC |
| TEST | 3, 1 (GND) | Used to test the output of the airflow transducer. | Airflow Sensor (1-5 VDC) |
| REMOTE | 2 (24 vac), J1 Pin 1 (24 vac†) | Remote Occupancy Contact | Dry contact switch with 24 vac supplied by power connection |

LEGEND

W — Wiper of Potentiometer

*Required whenever ducted heat is to be controlled. If monitoring of supply air is required the zone controller must be configured for heat even if the box does not contain heat. It is also required for stand-alone operation.

†Primary air sensor is required whenever unit is configured as a master zone controller and a non-CCN air source is used.

**24v connection (J4-16) is required for RH sensor only.

Table 3 — 33ZCVAVTRM Zone Controller Outputs

| CHANNEL (10-13) | J5 TERMINATIONS | DESCRIPTION |
|-----------------|-----------------------------------|--|
| DMPR_CCW | 1*,2 | Primary Damper CCW (factory wired) |
| DMPR_CW | 2,3* | Primary Damper CW (factory wired)† |
| HEAT_ST1 | 4, 5 (24 VAC externally supplied) | Heat Open, First Stage (field wired) |
| HEAT_ST2 | 6, 5 (24 VAC externally supplied) | Heat Close, Second Stage (field wired) |

*These terminals provide 24 VAC-output power to the load.

†The zone controller comes wired and configured for clockwise closure of the primary air damper. Do not change wiring to change rotation. The installer should configure the rotation decision with Carrier software to ensure transducer calibration integrity.

VAV Fan Terminal Zone Controller (33ZCFANTRM) — The input and output channel assignments are shown in Table 4.

The zone controller provides eight analog inputs.

ANALOG INPUTS — The analog inputs consist of four thermistor type inputs and four 0 to 10 VDC inputs. The thermistor inputs conform to the nominal 10K thermistor values in Table 1.

TRIAC OUTPUTS — The zone controller has four 24-VAC triac outputs on the baseboard and two on the output board. These outputs are capable of switching 24 VAC at 1 Amp with a power factor of 0.8. Two triacs control the primary damper.

One triac is used to rotate the damper clockwise and the other is used to rotate the damper counterclockwise. The two other triacs are dedicated to the control of either proportional or two position heat and are used to control the secondary damper actuator.

The specific output requirements for the air terminal applications are given in Table 5.

RELAY OUTPUTS — These relays are designed to switch 24 VAC as a maximum voltage at up to 1 amp with a power factor of 0.8. The relays provide fan off/on control and control a third stage of electric heat if used.

→ **Table 4 — Zone Controller Inputs (33ZCFANTRM)**

| CHANNEL NAME | J4 TERMINATION | DESCRIPTION | DEVICE |
|--------------|--------------------------------|--|---|
| SPT | 14,12 (ground) | Space Temperature Sensor (33ZCT55SPT), field installed and wired | 10K Thermistor |
| SAT | 10,12 (ground) | Supply Air Temperature Sensor, required for heat, field installed and wired* | 10K Thermistor |
| SP_OFFST | 12 (ground), 8 | Set Point Offset Adjust, requires the use of field-installed 33ZCT56SPT space temperature sensor | 100K Potentiometer |
| PATEMP | 4, 6 (ground) | Primary Air Temperature Factory option field installed and wired† | 10K Thermistor |
| RH/IAQ** | 16 (24v), 15 (+), 13 (-) | RH/IAQ Sensor Factory option, field installed and wired | 0-10 VDC |
| DMPPOS | 9 (10v), 7 (W+), 5 (-) | Primary Damper Position Factory Supplied and wired with zone controller | 0-10 VDC |
| TEST | 3, 1 (GND) | Used to test the output of the airflow transducer. | Airflow Sensor (1-5 VDC) |
| SEC Flo | 9 (10v), 11 (+), 13 (-) | Secondary Airflow Sensor†† | 1-5 VDC |
| REMOTE | 2 (24 vac), J1 Pin 1 (24 vac†) | Remote Occupancy Contact | Dry contact switch with 24 vac supplied by power connection |

LEGEND

W — Wiper of Potentiometer

*Required whenever ducted heat is to be controlled. If monitoring of supply air is required the zone controller must be configured for heat even if the box does not contain heat. It is also required for stand-alone operation.

†Primary air sensor is required whenever unit is configured as a master zone controller and non-CCN air source is used..

**24v connection (J4-16) is required for RH sensor only.

††Option required on Constant Volume Dual Units for zone pressure control. 33ZCSECTRM is required.

Table 5 — 33ZCFANTRM Zone Controller Outputs

| CHANNEL (NUMBER) | J5 TERMINATION'S | DESCRIPTION |
|------------------|---|---|
| DMPR_CCW | 1*, 2 | Primary Damper CCW (factory wired) |
| DMPR_CW | 2, 3* | Primary Damper CW (factory wired)† |
| HEAT_ST1 | 4, 5 (24 VAC externally supplied) | Heat Open or Heat First Stage (field wired) |
| HEAT_ST2 | 6, 5 (24 VAC externally supplied) | Heat Close or Heat Second Stage (field wired) |
| FAN | J6-1(24 VAC externally supplied), J6-2 (Common, N/O) | FAN Fan Start/Stop |
| HEAT_ST3 | J7-1 (24 VAC externally supplied), J7-3 (Common, N/O) | Heat Third Stage |
| 2_DMP_CCW | J8-1, J8-2 | Secondary Damper CCW |
| 2_DMP_CW | J8-2, J8-3 | Secondary Damper CW |

*These terminals provide 24 VAC-output power to the load.

†The zone controller comes wired and configured for clockwise closure of the primary air damper. Do not change wiring to change rotation. The installer should configure the rotation decision with Carrier software to ensure transducer calibration integrity.

NETWORK SYSTEM DESIGN INFORMATION

Design Considerations — A VAV system consists of a number of air terminals, an air source, and one or more CCN bus segments. The CCN bus is used by the terminals and air sources to exchange information. The information shared between the air source and the air terminals is called linkage information. The CCN bus segments should follow all specifications for a CCN bus, except as noted within this application document.

Air terminals that make up a VAV system must be connected to the same CCN bus. If the entire CCN system consists only of these terminals and their air sources, then this bus may be the primary bus.

Typically there will be other devices on the CCN system. In this case, the terminals will be placed on a secondary bus. This secondary bus will be isolated from the primary bus by a CCN bridge device. Isolation of the secondary bus allows the VAV system to have complete access to the CCN bus without regard to bus traffic caused by other CCN devices that are outside of the VAV system. This is important since proper operation of the VAV system requires timely communications between the linkage master and its linked terminals and the air source. Air sources (when Linkage compatible) may be connected to either the primary or secondary bus. Multiple VAV systems may occupy the same bus. The bus will operate at 9600, 19200, or 38400 baud.

Network Design

COMMUNICATION LIMITATIONS

At 9600 Baud — The number of controllers are limited to 128 zones maximum, with a limit of 8 systems (Linkage Masters configured for at least 2 zones). Bus length is required not to exceed 4000 feet with any more than 60 devices on any 1000-foot section. Repeaters are required every 1000 feet with a maximum of 3 repeaters per bus.

At 19,200 and 38,400 Baud — The number of controllers are limited to 128 maximum, with no limit on the number of Linkage Masters. Bus length is required not to exceed 4000 feet with any more than 60 devices on any 1000-foot section. Repeaters are required every 1000 feet with a maximum of 3 repeaters per bus.

COMMUNICATION ADDRESSING — The air terminal that has the linkage master function enabled will be the highest addressed terminal within its linked group of terminals. All terminals within the linked group will be addressed with consecutive descending addresses starting from the linkage master. Each linkage master will utilize broadcast to transmit data to all the zones in its system, therefore a single zone controller per bus, which is not the linkage or schedule master, must be designated as the broadcast acknowledger. One broadcast acknowledgment is required per bus.

Each controller will default to an address of 0, 140 when its application software is initially loaded. Since multiple controllers will be on the same bus, a unique address must be assigned to each controller before the system can operate properly. The assignment of controller addresses will be performed through Network Service Tool software.

OCCUPANCY SCHEDULING — Each zone controller is equipped with a software clock and is capable of performing its own occupancy scheduling once set up properly. If the control is configured to use a global occupancy schedule, a global schedule in an air terminal or networked device is used to determine occupancy status.

In order to provide occupancy status, the software clock needs to be initialized by a CCN device that contains a hardware clock. The software time clock will require periodic updates from a time broadcaster in a networked device (with hardware clock). Devices such as Comfort Controllers, PICs, and 33CS monitor thermostats all have hardware clocks. A device with a hardware clock must be set up as a time broadcaster. If the software clock has not been initialized, the zone controller will default to the occupied mode.

The zone controller supports the broadcast function. The zone controller will broadcast its schedule occupancy status upon transition and every 15 minutes when configured with a global schedule (schedule number 65 or greater) and as a master zone controller. Global schedule enables the master zone controller to provide occupancy scheduling to all the zone controllers within a given system.

The software time clock must be initialized after any power failure, either by receiving a Time Broadcast (the controller will request time from the network), or by a manually updating the time, through the controller time function.

→ **Network Addressing** — Use the following method when all the zone controllers are installed and powered, and the SPT sensors are wired and functioning properly. This method can be used if no addresses have been set previously. The address of an individual zone controller may be set by using the address search function on the Service Tool software when it is directly connected to the service port of the zone controller and the CCN bus is disconnected. This is the standard method of setting the address.

Addresses may also be set using the Service Tool Address Search Function if the zone controller is isolated from the CCN bus.

Each zone controller will default to an address of 0, 140 when its application software is initially loaded. Since multiple controllers will be on the same bus, a unique address must be assigned to each controller before the system can operate properly. The assignment of controller addresses will be performed through software by using the Address Search function of the Network Service Tool, as follows:

1. The software recognizes that the Zone Controller's address, stored in the zone controller memory, has not been written yet (this will be true when the unit is first powered up on the job, or after a jumper-initiated reset).
2. Press the override button on the SPT (terminals J4-14 and J4-12 are shorted) for 1 to 10 seconds.
3. The zone controller address changes from 0, 140 to 239, 239 for a period of 15 minutes.
4. Use Network Service Tool to change the address from 239, 239 to a valid system address within 15 minutes.

NOTE: If the address is not changed from 239, 239 to a valid system address within 15 minutes, the controller will revert to address 0, 140 and use of the override button will cause the address function to repeat. The operator **MUST** actively set the address even if the final desired address is 0, 140.

Zone Controller User Interfaces — The Zone Controller is designed to allow a service person or building owner to configure and operate the unit through the CCN user interface. A user interface is not required for day-to-day operation. All maintenance, configuration, set up, and diagnostic information is available through the Level II communications port on the zone controller. The data port allows data access by an attached Network Service Tool, ComfortVIEW™, or ComfortWORKS® software.

LINKAGE

Linkage is defined as the process that links the terminals and air source to form a coordinated HVAC system. Linkage allows the air source to respond to changing conditions in the zones. Linkage also allows the terminals to respond properly to changes in the air source operating mode. Linkage operation is different between a CCN device that supports linkage (i.e., 48/50 series, E series, F series, M series or PIC controlled air handler unit, PIC, *AirManager*TM, Comfort Controller), versus that which does not support Linkage.

CCN Air Sources or Air Sources Which Support Linkage — All terminals that are serviced by an air source are linked together to form a single virtual load to the air source. As such, the linked system provides the following information to the air source equipped with a CCN control that supports linkage:

- weighted average temperature of all zones serviced by the air source
- weighted average occupied temperature of all occupied and biased occupied zones serviced by the air source
- weighted average of all the occupied and unoccupied heating and cooling space temperature set points for all the zones serviced by the air source
- composite Occupancy information

To account for variations in the size of the space serviced by each zone, the space temperature and set point information provided to the air source is weighted. The weighting is proportional to the size of the zone and is determined by the configured maximum cooling capacity (CFM) for each zone. Only those zones with a valid temperature are included in the polling process.

In each linked system, one zone controller should be identified as the linkage master. The linkage master periodically polls the other zones in the group to acquire their temperature, set points, occupancy information, and damper position. The linkage master processes this information into a composite view of the system and sends this information to the air source.

These modes determine the operating and control modes of the zone controller. The operating mode will be used to provide status information about the zone controller's operation. The control modes will be used to affect the operation of the

corresponding control functions (airflow, heating, and fan control). The current operating and control modes will be based on the following inputs: the air source mode, the temperature control requirement of the zone, and the terminal type.

The air terminal operating mode will indicate the current HVAC mode of operation. The modes and their meanings are defined in Table 6.

AIR TERMINAL MODES — The heating mode will determine whether the heat function should be enabled or disabled. The fan control will control the fan as required for heat.

The air source mode is used by the zones to determine their terminal operating mode and which minimum and maximum airflow requirements to utilize. For stand-alone units without linkage, the supply air temperature sensor performs this function. The optimal start bias time will be used by the occupancy control in each terminal to adjust the terminal's occupied start time.

If the Linkage Master zone controller is enabled, then that zone controller will poll the indicated number of zones, including itself. With the information obtained, the linkage master will calculate the system control information and send them to the air source at the indicated address. The linkage master computes the composite occupancy, set point, and zone temperature data.

The linkage master calculates a static pressure reset value based on the damper positions of the linked zones. The static pressure reset value will be based upon the position of the most open damper in the system and is limited to a maximum allowable reset value. This value will then be sent to the air source by variable name.

Non-CCN Air Sources or Air Sources That Do Not Support Linkage — In systems with Non-CCN central air sources or central air sources which do not support Linkage, the zone coordination function of Linkage can still be provided by the Linkage function contained within a master zone controller. In these cases, the zone configured as the Linkage Master will determine the operational mode of the air source through its own airflow sensor and a primary air temperature measurement. A field-supplied primary air temperature sensor (33ZCSENPAT) is required. The modes that can be determined are either Cooling, Heating, free cooling, or Off.

Table 6 — Air Terminal Operating Modes

| AIR TERMINAL OPERATING MODE | AIR TERMINAL ACTION |
|-----------------------------|--|
| OFF | No active control of temperature or CFM in the zone. |
| VENT | Temperature requirement of the zone is satisfied. Minimum cooling CFM or damper position is maintained. |
| VENT and FAN | Temperature requirement of the zone is satisfied and CFM is below fan ON limit (parallel fan only). |
| COOL | Zone Controller is attempting to cool the zone by using supply air. |
| DEHUMIDIFY | Zone Controller is attempting to dehumidify the zone by overriding temperature control CFM requirements. |
| IAQ | Zone Controller is attempting to increase zone ventilation by overriding temperature control CFM requirements. |
| HEAT | Zone Controller is attempting to heat the zone by using supply air or local heating. |
| WARMUP | Zone Controller is attempting to heat the space during the morning warm up period. |
| REHEAT | Zone Controller is attempting the heat the zone by locally re-heating the supply air (single duct only). |
| PRESSURE | Zone Controller is participating in the pressurization mode of the system. |
| EVACUATION | Zone Controller is participating in the evacuation mode of the system. |

The Linkage Master will determine if the air source is operational (the fan is on/off) by determining if terminal airflow can be achieved. If the terminal's damper is open and the controller does not measure a corresponding minimum airflow, then the linkage master zone controller concludes that the air source is off. If airflow is achieved, then the linkage master concludes that the air source is on.

Once the air source is determined to be operational, the linkage master will attempt to determine the air source mode (heating or cooling) by measuring the supply air temperature from the air source. A primary air duct temperature sensor must be connected to the primary air temperature input of the linkage master zone controller. The sensor should be placed in the supply air duct at a point where airflow is not dependent on any specific terminal. If a sensor is not installed, or the sensor fails, then the linkage master will default the mode to cooling.

If the PAT sensor is installed and operational, the linkage master determines the air source mode (Heating or Cooling On/Off) based on the temperature reading.

→ OFF MODE — Off mode is determined when the minimum cooling CFM for the linkage master zone is configured with a value other than zero. The linkage master calculates the CFM for that master zone and compares it that value to the configured minimum cooling CFM for that zone. If the actual CFM is less than the minimum cooling CFM and the damper position is opened greater than the configured maximum damper position (as defined by the configured Reset Maximum Damper Position in the Linkage Configuration [MAXDP]) for 1 minute, then the linkage master zone controller will declare the primary air source's fan OFF. The linkage master will then issue the OFF Mode to all zone controllers associated (linked) with that master.

If the airflow increases above the minimum cooling CFM, then the linkage master zone controller will determine the primary air source's fan is on. Once the Master zone controller determines the fan is on, it then proceeds to determine if the equipment is operating in Heating, Cooling, or Free Cooling mode.

HEAT MODE — When the fan is determined to be on, the linkage master zone controller reads the primary air temperature value. If the temperature is greater than the average occupied zone temperature, as calculated by the linkage master zone controller, plus 5 degrees F, the mode is determined to be heating.

In heating mode, the zone controller will modulate the primary air damper to maintain the minimum heating CFM, unless the system is configured for VAV Central Heating. If a zone controller is configured for VAV heating, the zone controller will modulate the primary air damper between the minimum and maximum Heating CFM positions.

COOL MODE — When the fan is determined to be on, the linkage master zone controller reads the primary air temperature value. If the temperature is less than the average occupied zone temperature, as calculated by the linkage master zone controller, minus 2 degrees F, the mode is determined to be cooling.

FREE COOLING MODE — The following conditions must be present for free cooling mode:

- the fan is determined to be on by the linkage master zone controller
- the average zone temperature value is greater than the average unoccupied zone cooling temperature set point, as determined by the master zone controller
- the current time is between 3:00 AM and 7:00 AM
- the equipment is providing cooling to the system

If the above conditions are true, then the mode is determined to be Free Cooling. This mode is then communicated to all the zone controllers associated (linked) with that master zone controller.

NOTE: Any time a zone controller is not receiving an update from a linkage master zone controller, that zone controller will determine the air source mode based upon its supply air sensor (only if the zone controller is configured for ducted heat). In this case, no determination for heat, cool and on/off modes is made until after the heating operation ceases. In other cases where a supply air temperature sensor is not used, the mode will default to cooling.

Communications Alarms with Linkage — If the linkage master detects that a previously polled air terminal is no longer responding, then it will generate a CCN alarm message indicating the loss of communications with that terminal.

If a terminal that was previously polled by a linkage master stops being polled, it will generate a CCN alarm message indicating a loss of communications from the linkage master. It will then operate in stand-alone mode (Linkage in effect = NO). A return to normal will not be issued until successful communication updates have been received.

If the linkage master fails to communicate with the configured CCN air source, then an air source communication alarm message will be generated. The linkage master will operate as defined for a Non-CCN air source to determine the air source-operating mode.

OCCUPANCY (LOCAL/GLOBAL)

Overview — Each zone controller has a software time-clock. The software time clock must be initialized after any power failure, either by receiving a Time Broadcast (the controller will request time from the network), or by a manually updating the time, through the controller time function.

When designing a system with an air source (that has a PIC that supports linkage), the linkage master zone controller will determine the system scheduling if local occupancy schedules are used at each zone controller.

NOTE: The PIC should be configured with a similar time schedule as the linkage master, so in the event of a failure the PIC will automatically revert back to its configured schedule.

The system occupancy function will provide to the air source a composite view of the current occupancy status of all the zones. If any zone is occupied, the system will indicate to the air source that it should be in occupied mode. If no zones are occupied then the system will indicate to the air source that it should be in unoccupied mode. In addition the system will provide a composite view of the next occupied time, next unoccupied time, and last unoccupied time for the zones.

NOTE: If a single occupancy schedule is used, it should be configured in the linkage master, although it is not required.

Local Occupancy — Each zone controller will have its own time schedule through which its occupancy state is controlled.

When the control is configured to use its local occupancy schedule, and the zone controller's software time clock has been initialized, then the local schedule shall determine occupancy status.

The software timeclock will require periodic updates from a time broadcaster in a networked device (with hardware clock). If the software clock has not been initialized, the zone controller will default to the occupied state.

Global Occupancy — A zone controller's occupancy state can be controlled through the network. This will be referred to as global occupancy. Any zone can be configured to broadcast a global occupancy schedule to any zone controller on any bus with the same schedule number. Each CCN system can support up to a maximum of 35 global occupancy schedules.

The schedule master broadcasts its occupancy status upon transition and every 15 minutes, whenever it is configured as a global schedule (schedule number 65 to 99).

All the controllers on any CCN bus that are using the same global schedule need to be configured for the same schedule number.

→ **Remote Occupancy Contact** — The remote occupancy contact can be used to provide a room occupancy sensor input to the zone controller. If the remote occupancy contact input is in the off position the zone controller will transition to unoccupied. If the remote contact input is in the on position the zone controller will follow its local occupancy schedule.

Occupancy Override — The occupancy function will support a timed override function. The timed override will be activated through the space temperature sensor override button. If the override is activated in a zone that is receiving a global time schedule, then the override will be reported to the device issuing the global schedule. The device will then update the occupancy status of the zones receiving the schedule.

NOTE: All zones sharing a global occupancy schedule will be overridden to the occupied mode if any one of the space temperature sensors report an override. For zones that require individual overrides, those zones will have to use a local schedule.

Manual Occupancy Override Function — By using a CCN user interface, the user is able to command a timed override by entering the number of hours of override hours (0 to 4 hours). A manual entry greater than 0 will bring the zone controller schedule into the occupancy mode. This function is defined as manual override.

If the occupancy schedule is occupied when the manual override is downloaded, the current occupancy period will be extended by the number of hours downloaded. If the current occupancy period is unoccupied when the occupancy override is initiated, the mode will change to occupied for the duration of the number of hours downloaded.

If the occupancy override is due to end after the start of the next occupancy period, the mode will transition from occupancy override to occupied without becoming unoccupied, and the occupancy override timer will be reset.

An active manual occupancy override or a pending occupancy override may be canceled by downloading a zero to this configuration. Once a number other than zero has been downloaded to this configuration, any subsequent downloads of any value other than zero will be ignored by the zone controller.

Once the override period has expired, the value is reset to 0 and the manual override function is complete. If the override is activated in a zone utilizing local occupancy scheduling, then only that zone is affected. The override will occur for the time configured for that device.

Occupancy Table Format — The occupancy table is common to both a local and global occupancy function. For flexibility of scheduling the occupancy programming is split into eight separate periods. The configuration consists of eight fields corresponding to the seven days of the week and a holiday field in the following order: Monday, Tuesday, Wednesday, Thursday, Friday, Saturday, Sunday, Holiday. The occupancy time is configured in hour and minutes in military time.

The format of the schedule and the calculations performed on the schedule data is shown in Fig. 5.

Optimal Start Operation — For local occupancy, the occupancy function will factor in the occupancy bias time supplied by the linkage function. This bias time will cause the occupancy period to start earlier by the amount indicated by the bias time. The occupancy function will provide information so that the rest of the zone controller functions can differentiate

between biased occupied periods and configured occupied periods.

The Start Bias Time (in minutes) is calculated by the air source as needed to bring the temperature up or down to meet the set point under the optimal start routine. This value will be sent to all associated zones for optimal start of zone controllers.

SYSTEM OVERRIDE MODES

The system will react to four override modes reported by the air source compatible with linkage: pressurization, evacuation, nighttime free cooling (NTFC), and morning warm up.

Pressurization — In Pressurization mode, the system will bring in as much outside air as possible in order to pressurize the area. This mode is used for smoke control and prevents smoke from entering into an area that is adjacent to an area of smoke.

Each zone controller will modulate its damper to provide maximum cooling airflow into the space. If the terminal contains a series fan, the fan will be turned on. If the terminal contains a parallel fan it will be turned off. If the terminal contains auxiliary heat, the heating will be controlled so as to maintain the current heating set point. Secondary dampers in a zone pressurization application will be closed.

Evacuation — In Evacuation mode, the system will attempt to remove smoke from an area by creating a negative pressure. Either a return air fan in the air source, or some other fan mechanism will be used to exhaust the smoke filled return air from the space. The terminals will respond by closing their dampers and turning off all fans. Secondary dampers in a zone pressurization application will be open.

Night Time Free Cooling (NTFC) — In NTFC mode, the system is attempting to use cool night time (3 AM to 7 AM) outside air to cool down the space. In this mode, the air source will operate its fan and mixed air dampers to provide outside air to the system. The air terminals will act as if they are in the Occupied Cooling mode except that the temperature control set point will be the midpoint between the occupied cooling and heating set points rather than the occupied cooling set point.

Morning Warm-Up — In Morning Warm-up mode, the air source provides central heating. Morning warm-up will run once per day and will start at the time indicated by the earliest occupied zone (biased by the optimal start calculation). If VAV central heating is enabled, then the zone controller will modulate air flow between the minimum and maximum heating cfm limits to achieve its occupied heating set point.

SET POINT GROUPING

Each zone controller will contain a set point schedule. This schedule will contain temperature, humidity, and air quality set points. The set point data may be unique to the zone controller or multiple zone controllers may be grouped together to share the same temperature set points.

The controller contains a Set Point Group Number configuration parameter and a Set Point Group Master configuration parameter. When a zone controller is configured as Set Point Master, the zone controller will broadcast its set points to other zone controllers that are configured to accept the Broadcast Set Point Schedule. If a zone controller is not configured to use global set points, the zone controller will use its own onboard set point schedule. The Set Point Master is independent of the Master Linkage zone controller. There can be 16 Set Point Group functions per CCN bus. Global set points will not be transmitted through CCN bridges.

→ **SPACE TEMPERATURE SHARING**

Each zone controller has the capability to share its local sensor and temperature offset with other zone controllers. Each

```

- OCCPC64S - # 30          MODIFY CONTROLLER CONFIG
-----
Save Upload Download Copy Edit Quit
Modify data; Press F2 to activate menu.                               Replace
-----
Air Terminal Controller Configuration
-----
      DESCRIPTION              STATUS          POINT
-----
Manual Override Hours          0          hours          OVRD
Period 1: Day of Week          11111111          DOW1
Period 1: Occupied from        0:00          OCC1
Period 1: Occupied to         24:00          UNOCC1
Period 2: Day of Week          00000000          DOW2
Period 2: Occupied from        0:00          OCC2
Period 2: Occupied to         24:00          UNOCC2
Period 3: Day of Week          00000000          DOW3
Period 3: Occupied from        0:00          OCC3
Period 3: Occupied to         24:00          UNOCC3
Period 4: Day of Week          00000000          DOW4
Period 4: Occupied from        0:00          OCC4
Period 4: Occupied to         24:00          UNOCC4
Period 5: Day of Week          00000000          DOW5
Period 5: Occupied from        0:00          OCC5
Period 5: Occupied to         24:00          UNOCC5
Period 6: Day of Week          00000000          DOW6
Period 6: Occupied from        0:00          OCC6
Period 6: Occupied to         24:00          UNOCC6
Period 7: Day of Week          00000000          DOW7
Period 7: Occupied from        0:00          OCC7
Period 7: Occupied to         24:00          UNOCC7
Period 8: Day of Week          00000000          DOW8
Period 8: Occupied from        0:00          OCC8
Period 8: Occupied to         24:00          UNOCC8
-----
Local Connect  -FARM - Carrier Controls          12:13:24 18-Aug-99

```

Fig. 5 — Occupancy Schedule Information Screen

zone controller can be configured as a broadcaster of its sensor or a receiver of another zone's sensor information. Zone controllers sharing a common sensor must all be installed on the same CCN bus. Sharing of sensor information cannot be accomplished through bridges.

→

SENSOR GROUPING

A zone controller that is set up as a Linkage master has the ability to poll its slave controllers and collect the high, low or average value of any variable within its slave controllers. Once the high, low or average is determined, the master can then transfer that value to a configured bus number, element number and point name. Typically this feature is used to determine a system's highest indoor air quality reading for use in a Demand Controlled Ventilation (DCV) system.

In order to utilize this feature, the CCN Variable Name being collected from the slave controllers must be supplied. Also the data transfer rate must be specified and whether the high, low or average value is being calculated. Finally, a valid point name and CCN address must be entered.

CALIBRATION

The zone controller provides a Commissioning mode that calibrates the damper position feedback sensor and the airflow sensor. This commissioning should be performed once when the terminal is installed. In addition, the zone controller will perform an ongoing auto-calibration of the airflow sensor to maintain airflow measurement accuracy. Refer to installation and start up instruction for more details.

CCN ALARMS

The zone controller will support the detection of alarm conditions and the reporting of those conditions through the CCN communication network. No local indication of any alarms will be provided at the zone controller itself. Alarms will be routed to CCN devices as required by setting the appropriate routing bits in the alarm routing configuration. No alarms will be

transmitted if alarm routing is set to 00000000 (default). The control implements and uses a standard alarm configuration table, specifying routing, re-alarm, etc. Alarms use level 6 (control) for limit-exceeded alarms, and level 2 (service) for all other alarms. Alarm activity is stored in an Alarm History Table, containing the 5 most recent alarm messages. The following CCN alarms and associated return to normal messages are supported.

Space Temperature Limit Alarm — During occupied periods, an alarm value is used to define the allowable deviation from set points before an alarm condition is detected. This value is added to the occupied cooling set point and subtracted from the occupied heating set point during occupied periods. This allows the set points to be easily changed without having to change the alarm limits. During normal steady state operation, whenever the space temperature deviates outside of this defined range, a timer will begin. If after 5 minutes the alarm condition still exists, the alarm will be generated. An alarm value of 1 degree F (non-adjustable) is used to determine when the space temperature has returned to normal.

During unoccupied and biased start periods, the alarm set points are defined by two configured values (unoccupied low and unoccupied high). The alarm detection and return to normal operates as specified above for occupied conditions, except unoccupied alarm values are used.

To prevent false alarms during a transition from Unoccupied or Biased Occupied operation to Occupied operation (or if a set point is changed), an alarm delay is calculated each time the control set point changes. The value of the delay is equal to 15 minutes, plus 15 minutes per degree difference between the new heating or new cooling set point and the current space temperature. The alarm delay has a maximum value of 255 minutes.

Linkage Failure (Failure to Communicate With Linkage Master) — If a terminal has established communications from a linkage master, then the linkage master will exchange information with each of the configured zones each

minute. If a zone fails to receive updates from the linkage master for 5 sequential times (greater than 5 minutes without successful communications), then a Linkage Failure communication alarm is generated. The alarm is generated from the zone that indicated loss of communication with Linkage Master. To determine when communications have returned to normal, the controller will continue to monitor the communication status. After 5 sequential successful communications, then a return to normal message is generated, although normal operation will resume after the first successful communication.

Linkage Failure (Failure to Communicate with Air Source) — If a zone controller has been configured as the linkage master, and an air source address has been configured to a value other than the default, then the linkage master zone controller will exchange information with the configured air source once each minute. The air source must be Linkage compatible.

If the air source fails to respond, then the linkage master will attempt to retry communication. If unsuccessful, the linkage master will log the attempt as a failure. If 5 sequential failures occur (more than 5 minutes without successful communication), then a Linkage Failure communication alarm is generated for the air source. The alarm indicates a Linkage Air Source Failure at address X, X (where X, X is the failed air source address). To determine when communications have returned to normal, the controller will continue to monitor the communication status. After 5 sequential successful communications occur, a return to normal message is generated.

Supply Air Temperature Sensor Failure — For any zone where ducted heat is configured, if the supply air temperature sensor fails then a Supply Air Temperature Sensor Failure alarm for that zone is generated. The zone controller will wait 2 minutes before generating the alarm. A return to normal (or reset of the time delay) occurs immediately upon the detection of a normal temperature or if the ducted heat is configured to No.

Primary Air Temperature Sensor Failure — For any linkage master where the air source address is NOT configured (default value), if the primary air temperature sensor fails then a Primary Air Temperature Sensor Failure alarm is generated. The alarm is generated after a 2 minute delay. A return to normal (or reset of the time delay) occurs immediately upon the detection of a normal temperature or if an air source address is configured.

Pressure Sensor Low Airflow Pressure Alarm — Any time the value of the input channel voltage falls below a minimum acceptable value (0.89 V), then a Low Airflow Pressure alarm will be generated for that zone. For all control types except Dual Duct or Room Pressure Control, the alarm indicates an Airflow Sensor Low Pressure alarm.

For Dual Duct and Zone Pressure Control applications, both primary airflow and secondary airflow sensors are monitored for this condition. The appropriate alarm message is generated, based upon the sensor failure detected.

To determine when normal conditions have returned, the zone controller will continue to monitor the input. When the voltage rises to within tolerance (above 0.91 V), a return to normal message is generated.

NOTE: A value of 0.89 volts is the minimum acceptable 0 in. wg value.

Pressure Sensor High Velocity Pressure Alarm — Any time the calculated value of the measured velocity pressure exceeds the configured maximum value for more than 5 minutes, then a High Velocity Pressure alarm is generated for that zone. The range is 0.250 in. wg to 2.000 in. wg. The default is 1.200 in. wg. For Dual Duct and Room

Pressure Control applications, both primary airflow and secondary airflow sensors are monitored for this condition. The appropriate alarm message is generated, based upon the appropriate sensor measurement.

The zone controller will continue to monitor the input, and when the pressure falls below the alarm limit minus 0.1 in. wg, a return to normal message is generated.

→ **Relative Humidity Sensor Alarm** — If the controller is configured for Relative Humidity control and the value of the sensor exceeds the Relative Humidity High alarm limit or falls below the Relative Humidity Low alarm limit during occupied periods, then an alarm is generated. The condition must exceed the alarm limit for 5 minutes before the zone controller will issue the alarm.

The alarm will be generated only if Humidity Control is Enabled. A delay is applied whenever the control transitions to an occupied mode or if the control set point is changed in order to prevent false alarms. The delay is similar to the Space Temperature Alarm Limit Delay. The low Relative Humidity alarm has a configurable range from 0% to 100% and a default of 20%. The high Relative Humidity alarm has a configuration range from 0% to 100% and a default of 70%. A fixed hysteresis of 2% is used to determine when the conditions have returned to normal. Alarms can be generated during occupied and unoccupied times.

IAQ Sensor Alarm — If the zone controller is configured for IAQ control and the value of the sensor exceeds the IAQ High Alarm Limit or falls below the IAQ Low Alarm Limit during occupied periods, then an alarm is generated. The alarm condition has a delay of 5 minutes before the alarm to be generated.

The alarm is generated only if the IAQ control is Enabled. A 2-hour delay is applied whenever the zone controller transitions to an occupied mode, in order to prevent false alarms. The low IAQ alarm limit has a configuration range of 0 to 5000 (ppm) with a default of 0. The high IAQ alarm limit has a configuration range of 0 to 5000 (ppm) with a default of 2000. For flexibility, the limits for the IAQ alarm do not include units, but the IAQ sensor alarm descriptions (24-character text) include the default units ('PPM') as part of the description.

To determine when normal conditions have returned, the zone controller will apply a 2% hysteresis to the alarm limits, and generate a return to normal message when the sensor returns within range (2% of the alarm limit value).

Failure to Zero Calibrate Pressure Transducer — During the zero calibration procedure, if the airflow pressure input voltage fails to decrease to within the allowable zero pressure range, the zone controller will generate a Failure to Zero Calibrate Pressure Transducer alarm.

Damper Position and Actuator Installation — During the damper calibration procedure of the Commissioning Mode or during the zero calibration, after the damper is driven closed, the control will generate a Damper Actuator Failure to Close alarm if the corresponding damper position is not within the specified closed position range. The acceptable input voltage range is above 8.5 VDC for clockwise open and below 1.5 VDC for counterclockwise open. The damper position sensor has a 0 to 10 range.

CCN USER INTERFACE

The Points Display Table, Set Point Table, and Linkage Maintenance Table are shown to inform a user of what information is available to be accessed via CCN user interface, BEST++, DataPort, DataLink and BacLink Gateway. See Tables 7-9.

→ Table 7 — Points Display Table

| Table Name: POINTS | | | | |
|-------------------------|--------------|--------|------------------|--------|
| DESCRIPTION | STATUS/UNITS | POINT | RANGE | ACCESS |
| Terminal Mode | ASCII (8) | MODE | * | R |
| Terminal Type | ASCII (8) | TYPE | † | R |
| Controlling Set Point | XXX.X dF | CNTSP | -40.0 to 245.0 | R |
| Space Temperature | XXX.X dF | SPT | -40.0 to 245.0 | R/W |
| Primary Airflow | XXXX cfm | PRIFLO | 0 to 9999** | R/W |
| Primary Damper Position | XXX%OPEN | DMPPOS | 0 to 100 | R |
| Supply Air Temperature | XXX.X dF | SAT | -40.0 to 245.0†† | R/W |
| Local Heating Capacity | XXX% | HCAP | 0 to 100 | R |
| Terminal Fan | Off / On | FAN | 0 to 1 | R/W |
| Relative Humidity | XXX.X% | RH | 0.0 to 100.0 | R/W |
| Air Quality (ppm) | XXXX | AQ | 0 to 5000 | R/W |
| Secondary Airflow | XXXX cfm | SECFLO | 0 to 9999 | R/W |
| Primary Air Temperature | XXX dF | PATEMP | -40 to 245 | R/W |
| Heat | Dsa / Ena | HEAT | 0 to 1 | R/W |

*Mode can be set to OFF, HEAT, WARM-UP, VENT, FAN AND VENT, COOL, DEHUMIDIFY, REHEAT, PRESSURIZATION, EVACUATION, ZERO CALIBRATION, and COMMISSIONING.

†Type can be set to SINGLE DUCT, PARALLEL FAN, SERIAL FAN, and DUAL DUCT.

**Value set to zero if zone configured for Pressure Dependent operation.

††Value set to zero if not configured for ducted type heat.

||Only valid for zones configured as Dual Duct type or Pressure Control.

NOTE: All points are forcible except Terminal Mode (MODE), Terminal Type (TYPE), Primary Damper Position (DMPPOS), and Local Heating Capacity (HCAP).

→ Table 8 — Set Point Table

| Table Name: SETPOINT | | | | |
|-------------------------|--------------|--------|---------------|---------|
| DESCRIPTION | STATUS/UNITS | POINT | RANGE | DEFAULT |
| Occupied Heat | XX.X dF | OHSP | 40.0 to 90.0 | 70.0 |
| Occupied Cool | XX.X dF | OCSP | 45.0 to 99.9 | 74.0 |
| Unoccupied Heat | XX.X dF | UHSP | 40.0 to 90.0 | 69.0 |
| Unoccupied Cool | XX.X dF | UCSP | 45.0 to 99.9 | 75.0 |
| Relative Humidity | XXX.X % | RHSP | 0.0 to 100.0 | 60.0 |
| Unocc Relative Humidity | XXX.X % | UORHSP | 0.0 to 100 | 100 |
| Air Quality (ppm) | XXXX | AQSP | 0 to 5000 | 850 |
| Delta Airflow | XXXX cfm | DCFM | -9999 to 9999 | 0 |

→ Table 9 — Linkage Maintenance Table

| Table Name: LINKAGE | | | | |
|--------------------------|------------------|-----------|--------------|--------|
| DESCRIPTION | STATUS/UNITS | POINT | RANGE | ACCESS |
| Air Source Bus # | XXX | ASBUSNUM | | NONE |
| Air Source Element # | XXX | ASDEVADR | | NONE |
| Master Zone Element # | XXX | MZDEVADR | | NONE |
| Operating Mode | ASCII (8 char) * | ASOPMODE | | NONE |
| Air Source Supply Temp | XXX.X dF | ASTEMP | | NONE |
| Start Bias Time | XXX min | STRTRBIAS | | NONE |
| Average Occ Heat Setpt | XX.X dF | AOHS | | NONE |
| Average Occ Cool Setpt | XX.X dF | AOCS | | NONE |
| Average Unoc Heat Setpt | XX.X dF | AUHS | | NONE |
| Average Unoc Cool Setpt | XX.X dF | AUCS | | NONE |
| Average Zone Temp | XX.X dF | AZT | | R |
| Average Occ Zone Temp | XX.X dF | AOZT | | R |
| Composite CCN Value | XXX.X | CCCVAL | 0 to 9999.9 | NONE |
| Occupancy Status (1=Occ) | X | OCCSTAT | | R |
| Next Occupied Day | XXX | NEXTOCCD | | NONE |
| Next Occupied Time | XX:xx | NEXTOCCCT | | NONE |
| Next Unoccupied Day | XXX | NEXTUNOD | | NONE |
| Next Unoccupied Time | XX:xx | NEXTUNOT | | NONE |
| Previous Unoccupied Day | XXX | PREVUNOD | | NONE |
| Previous Unoccupied Time | XX:xx | PREVUNOT | | NONE |
| Maximum Damper Position | XX.X % | MAXDMPPOS | 0.0 to 100.0 | R/W |
| Static Press Reset | X.X "H2O | PRESVAL | 0.0 to 5.0 | R/W |
| Pressure Decrease Value | X.X "H2O | PRESDECR | 0.0 to 5.0 | R/W |
| Pressure Increase Value | X.X "H2O | PRESINCR | 0.0 to 5.0 | R/W |

*COOLING, HEATING, WARM-UP, FREECOOL, PRESSURE, EVAC, OFF.

APPLICATION

General — The zone controller is a CCN device that conforms to standard CCN communications protocol. The zone controller is capable of controlling Carrier and many non-Carrier air terminal units in networked or stand-alone applications. The zone controller includes an integrated modulating damper actuator. The zone controller provides Pressure Independent airflow control.

Each zone controller can operate in a stand-alone mode based on the sensors installed.

If the supply air sensor is not installed, the controller will assume that the air source is on and that the air source's operating mode is cooling. The zone controller will operate using only its minimum and maximum cooling CFM configuration limits. If the zone controller is equipped with ducted type heat, then when local heating is not active, the temperature read from the SAT sensor will be used to determine if the air source is heating or cooling. The appropriate minimum and maximum CFM limits (heating or cooling) will be used based on the air source operating mode.

NOTE: In this mode of operation, the minimum heat and cool limits must NOT be set to zero.

Finally, a primary air temperature (PAT) sensor can be connected to any stand-alone zone controller and mounted in the supply air duct where it is not affected by the airflow of a specific zone. In this case, the zone controller is configured as a Linkage Master zone with a system size of 1. In this configuration, the zone will determine the air source operating mode (OFF, COOLING, HEATING, or FREE COOLING). Because the PAT sensor is not affected by airflow at the zone, minimum airflow limits may be set to 0 cfm.

Each zone controller supports the following set points:

- occupied cooling
- occupied heating
- unoccupied cooling
- unoccupied heating

NOTE: The minimum differential between the heating and cooling set points is 1.0 degree F.

To provide an accurate low-end airflow measurement, the control performs an automatic zero calibration (ZeroCal) feature. The controller does this to account for any offset, which may be inherent in the airflow sensor.

The ZeroCal procedure will be performed every time the air source mode transitions to OFF. Additionally, for systems which operate continuously, a ZeroCal procedure will be performed every 72 hours. To prevent all the dampers from closing simultaneously, an offset time delay based upon the zone controller address is used.

The zone controller can be used in the following applications:

1. Single duct terminal applications
 - a. Cooling only
 - b. Staged electric heat
 - c. Hot water/steam heat (modulating or two-position)
2. Series fan terminal applications
 - a. Cooling only
 - b. Staged electric heat
 - c. Hot water/steam heat (modulating or two-position)
3. Parallel fan terminal applications
 - a. Cooling only
 - b. Staged electric heat

- c. Hot water/steam heat (modulating or two-position)
4. Dual Duct applications
 - a. Constant volume
 - b. Variable volume
 - c. VAV retrofit - cold deck close-off (requires total airflow probe)
 5. Constant ventilation (dual duct terminal with ducted outdoor air)
 6. Terminal cfm tracking applications (zone pressure control)

This section of the manual describes operating sequences for the zone controller in its various configurations and modes. It presents separate descriptions for single duct, series fan powered, and parallel fan powered air terminals in the following configurations: without local heat, with staged electric heat, and with hot water or steam heat (two-position or proportional). The system in which the zone controllers operate should also contain a control with linkage coordination or an air source with either a linkage compatible PIC, *AirManager*TM, or Comfort Control.

Each description is accompanied by figures depicting the hardware configuration and the sequence of control events for the application being described. In the control sequence diagrams the vertical axis represents airflow and the horizontal axis represents space temperature. The sequence of events for cooling operation reads from right to left, and the sequence of events for heating operation reads from left to right.

The zone controller employs proportional/integral/derivative (PID) control routines to provide precise, efficient, and stable control. The PID calculations take into account both the space temperature deviation from set point and the rate at which the temperature is changing.

General Heating Information — Heating may be one of two types, ducted or non-ducted. In a ducted heat type system, the heating mechanism is located within the air terminal, upstream of the supply air temperature sensor. The heating device may be either a hot water/steam heating coil or up to three stages of electric heat. Use of a air terminal heating coil will require that the zone controller be wired to a supply air temperature sensor. The SAT sensor will measure the supply air temperature into the zone. The SAT sensor will provide feedback to the auxiliary PID heating control loop and ensures that the supply air temperature does not exceed the configured maximum temperature.

→ There are four types of heat a zone controller can be configured for use with:

- modulating hot water/steam valve (VAV)
- modulating hot water/steam valve (CV)
- two-position hot water/steam valve
- electric heat (1 to 3 stages)

If a Heating Type is configured, but Ducted Heating is NOT selected, the heating control algorithm will not utilize an SAT sensor. A two-position heating valve or single-stage electric heat are most common, although the zone controller can operate up to 3 non-ducted electric heat stages. The zone controller will maintain the space temperature at the heating set point. The zone controller will wait for the Heat On Delay to expire before energizing any heating device.

For non-ducted, modulating hot water baseboard applications, the zone controller requires a 10K ohm leaving water sensor which is attached to the baseboard heater and wired to the SAT sensor input. This device is field-supplied.

NOTE: A 33ZCENSCHG changeover sensor can be used as a leaving water sensor.

If the zone controller is configured as a parallel fan type terminal, the zone controller will utilize the fan as the first stage of heat, regardless of the heat type configured. The amount of time the fan will operate as the first heat stage is determined by the value configured for the Heat On Delay (10 to 20 minutes recommended).

The Heat On Delay is used to prevent mechanical heating from being operated for a configured period of time. For single duct type terminals, a delay of 2 minutes (default value) allows the zone controller to increase the airflow to the desired reheat CFM before operating heat. For parallel fan type terminals, the default value is typically increased to 15 minutes to allow the fan to utilize heat from the ceiling plenum, before any additional mechanical heating is energized.

Disabling Reheat From CCN — The zone controller provides a means to disable the reheat function from the CCN. This is used to prevent zones that use a central heat source from using local heat. When the central heating source is not producing hot water or steam heat to the terminals (the boiler is disabled for example), a system mode broadcast can prevent these terminals from entering reheat mode. By preventing reheat, the zone controller will control to the minimum cooling CFM rather than the higher reheat CFM. This will prevent more cool air from entering into the space when heating is actually required.

The HEAT ENABLED variable is located in the display table for each zone controller and can be forced from the CCN. Normally when the zone controller is in heating, this variable will indicate ENABLE. To disable heating when the central heat source is off, this variable must be forced to DISABLE. This force should occur at least once an hour and sent to all zone controllers that are supplied heat from the central source. This application will require the use of a Comfort Controller or data transfer module to accomplish this function.

Non-Ducted Heat Control (Single or Staged Heat) — Either zone controller can support the non-ducted heat function. The non-ducted heat function can be configured for either single duct units, fan powered parallel, or fan powered series applications or constant volume dual duct applications where auxiliary perimeter heat is provided. Heat needs to be controlled within the zone that is controlled by the terminal unit. Non-ducted heat can be applied to zone controller units configured as Dual Duct Units which have additional perimeter heating.

In a non-ducted heat application, the heating controlled device is located within the space. The heating device is typically either a two position (On-Off) device like a hot water valve or electric baseboard heater. For this application, no heating control loop feedback is required. The installation of the supply air sensor is not required when the unit is configured for non-ducted heat.

Additionally, the zone controller can control a single stage, two-position, or multistage electric supplemental heat devices. The zone controller will only use space temperature as feedback into the temperature control loop to maintain the heating set point in these applications.

When the 33ZCVAVTRM or 33ZCFANTRM zone controllers are applied and configured for heat, and heating is being called for in the space, the zone controller reads the space sensor and the output is adjusted to satisfy conditions. The number of stages (if applicable) is determined by comparing space temperature with the current biased heating set point.

Configuration determines the logic output type for normally open or normally closed type two-position valves. Hysteresis is determined by the Heating Proportional Gain configured.

A terminal unit equipped with heating will provide the minimum heating CFM configured for the zone whenever the air source is in heat mode unless VAV central heating is enabled.

The heating control maintains the current heating set point (plus any offset from a 33ZCT56SPT sensor slide bar during occupied periods).

Modulating Baseboard Heating — The zone controller can provide control of modulating hot water (hydraulic) baseboard heating which provides perimeter heating for a zone. The zone controller can be used with single duct, fan powered, or dual duct terminals using perimeter hydronic heating. A field-supplied modulating (floating point type) water valve is used to control the flow of water through the baseboard hydronic heating coil. A field-supplied accessory temperature sensor (33ZCSENCHG) attached to the leaving water side of the hydronic baseboard heating coil is required to properly modulate the hot water valve.

NOTE: It is strongly recommended to mount both the temperature sensor and the modulating water valve to the leaving side of the hydronic heater. This will minimize installation time and improve valve life.

Ducted Heat Control (Staged or Modulating Device) — The zone controller can support a ducted heat function. The ducted heat function can be configured for either single duct units, fan powered parallel, or fan powered series applications where heat needs to be controlled within the zone that is supplied by the terminal unit.

For this application, heating control loop feedback is required. The installation of the supply air sensor is required when the unit is configured for ducted heat.

The zone controller can control a single stage, two-position, multistage electric heat, or a modulating hot water valve.

When the 33ZCVAVTRM or 33ZCFANTRM zone controllers are applied and configured for heat, and heating is being called for in the space, the zone controller reads the space sensor and the output is adjusted to satisfy conditions. The number of stages (if applicable) is determined by comparing space temperature with the current biased heating set point.

Configuration determines the logic output type for normally open or normally closed type two-position valves.

A terminal unit equipped with heating will provide the minimum heating CFM configured for the zone whenever the air source is in heat mode unless VAV central heating is enabled.

The heating control maintains the current heating set point (plus any offset from a 33ZCT56SPT sensor slide bar during occupied periods).

→ **Modulating Hot Water/Steam Valve CV** — The Modulating Hot Water/Steam Valve CV mode is designed to use modulating heat valve with a constant volume airflow. This mode of operation allows all CFM set points to be set to the same CFM value. The zone reheat will temper the supply air to maintain proper zone temperature at the configured constant volume of air.

VAV Central Heating — The use of the zone controller in a system allows for the application of VAV heating utilizing the heat from a central air source. Typically when a system is designed, the central heat is used for morning warm up only. The zone controller provides the ability to add heat to a system during the occupied mode from a central source. Terminal units designed without any local heat (ducted or non ducted), should utilize VAV Heating. During VAV heating, the zone controller modulates its primary air damper to provide heat when the air source is in Heat Mode. The airflow is controlled so that the zone achieves and maintains the desired heating set point.

In VAV central heating, the terminal provides a variable volume into the zone. The central supply air will be a source of heating when the air source is in the heating mode.

The zone controller temperature control loop determines the airflow set point that is required to maintain space temperature at the heating set point. Each zone controller modulates between the minimum heating cfm and the maximum heating cfm during central heating. This CFM should be limited to a configured range of values that allows the air source to operate properly in the heating mode.

▲ CAUTION

When using VAV Heating, it is the system designer's responsibility that the central apparatus is protected during heating to provide proper airflow over the central heating device. Ensure that there will be a minimum system airflow that will allow the air source to operate safely in the heating mode. The zone controller will allow for the option of disabling the VAV central heating function in a given zone. This means that a central air source may provide heating for the entire system, or possibly only provide it for those terminals without heat at the zone level.

In a system with an air source controlled by CCN device, the zone controller will notify the corresponding linkage master zone controller that the unit is heat mode or in morning warm up.

In the case of a non-CCN controlled air source, the zone controller should be set up as the linkage master for that air source. The zone controller will determine if the primary air temperature is greater than the weighted average space temperature, and if higher, then declares the central air source in heating.

VAV Central Heating with Ducted Zone Heat — When heating is available at the zone (ducted), and central heating is also available, the zone heat will work in parallel to provide heating to the space. This heating function provides the required volume of heated air from the central apparatus. This volume is determined by a PID airflow control, the space temperature, and the desired set point. In addition, the temperature of the air can be supplemented by the local heat source, if the current air temperature cannot meet zone requirements. Each zone controller configured for heat (ducted or non ducted) will operate its heating control loop when ever the space temperature is below the heating set point to determine a desired supply air discharge temperature that is necessary to maintain space temperature at the heating set point.

NOTE: Central heat with ducted zone heat requires a supply air sensor.

Morning Warm-Up — The zone controller performs Morning Warm-Up when its air source is in the Morning Warm-Up mode. During Morning Warm-Up mode, the zone controller operates the same as it does during heating. The zone controller uses its occupied heating set point during Morning Warm-Up, regardless of the current status of Occupancy. For series fan terminal applications, the zone controller turns on the air terminal's fan during Morning Warm-Up operation.

If the zone controller is configured to perform supplemental heating, it operates as defined for ducted or non-ducted heating as applicable.

Damper Override — Damper Override mode is initiated by the air source in response to input from a field-supplied smoke control panel. When the air source enters an override mode the linkage coordinator signals the zone controllers to take corresponding action. The override can take either of two forms: pressurization or evacuation. In Pressurization mode, the zone controller commands the air terminal's supply air

damper to maximum cool cfm. In Evacuation mode, it commands the damper completely closed.

Damper Override supersedes the cfm setting the zone controller would otherwise maintain based on space temperature. The smoke control panel that commands the override mode must be in accordance with local codes, as must its installation.

Nighttime Free Cooling — Nighttime Free Cooling (NTFC) is an air handler cooling function that can be employed during unoccupied periods when conditions permit. If outside air is acceptable, based on temperature and enthalpy, during unoccupied early morning hours, the air handler will deliver the cool outside air to the air terminals. When the air source indicates that NTFC is operating, the zone controller at each air terminal controls to midway between the occupied heating and occupied cooling set points, rather than to the higher unoccupied cooling set point that would otherwise be in effect at that time.

For series fan terminal applications, the zone controller turns on the air terminal's fan during NTFC operation.

NOTE: This feature is only available to CCN systems where fully compatible linkage air source controls are used.

Single Duct Terminal Applications — When applying the 33ZCVAVTRM zone controller, ducted heat can only be used when the air source is on, since the air source is providing the only means of airflow into the zone.

▲ CAUTION

The minimum airflow required by the heat at each terminal must be configured properly to protect and ensure proper heat transfer for the heating coil. If the minimum cooling cfm limit is below the terminal's recommended minimum value, use the reheat cfm limit for this configuration. The minimum heat cfm limit should also be set to this value.

Either model zone controller can support the Reheat function for single duct terminals.

With a single duct terminal application, if the central air source is on and in cooling mode and the terminal is equipped with heat, then the heat will be used to reheat the supply air to prevent over cooling of the space. Reheat will occur when the space temperature drops below the heating set point. The zone controller will enable the heating control algorithm. At this point the zone controller will provide primary airflow equivalent to the larger of either the minimum cooling CFM requirement (to satisfy the minimum air flow for the air source) or the reheat CFM requirement (to provide minimum airflow for the heating coil).

COOLING — The primary control function of zone controller is to provide cooling to the space by modulating the amount of supply airflow through its primary damper.

The Zone Controller uses pressure independent operation to control the amount of cool air entering the space. The control variable is terminal airflow (CFM). A PID temperature control loop determines the airflow set point needed to maintain space temperature at the cooling set point.

The airflow set point is limited to a configured range of values that allow the air source to operate properly in the cooling mode. These configured limits are listed in the Installation Instructions for the zone controller. The minimum limit ensures that the sum of all air terminal minimum requirements fall within the minimum cooling operating range of the air source. The maximum limit ensures that airflow will not increase above the maximum design value and that the noise level generated at this maximum airflow will be acceptable to the occupants of the zone.

The sequence of operation is as follows: when the space temperature is above the cooling set point and the air source is in the cooling mode, the zone controller modulates the air terminal's damper to supply airflow between minimum and maximum cooling airflow limits. A temperature control loop that maintains space temperature determines the airflow set point. As the space temperature falls below the cooling set point, the PID loop will reduce the airflow. When the space temperature drops and remains below the cooling set point, the zone controller will hold the airflow at minimum cooling limit.

In its standard operating mode the zone controller follows the same control sequence for cooling during both occupied and unoccupied periods. The zone controller's Occupancy schedule determines which set point the zone controller will use.

HEATING — There are two ways to use local heat. Reheat operates when the zone controller's zone requires heat and the air source is supplying cool air to satisfy cooling demand in other zones. Heat is also used to supplement air source heating while the air source is supplying heated air, but the temperature is inadequate to maintain the desired set point.

When the space temperature is below the Heating set point and the air source is in the heat mode, the zone controller modulates the air terminal's damper to supply airflow between minimum and maximum heating CFM (if configured for VAV central heating), otherwise the minimum heating airflow is maintained. During VAV heating, space temperature PID loop determines the airflow set point. As the space temperature goes above the heating set point, the PID loop will start reducing the airflow. When the space temperature remains above the heat set point, the zone controller will hold the airflow at minimum heating CFM.

Reheat — When the zone controller is applied to a Single Duct terminal unit and configured for heat, and heating is being called for in the space, the zone controller reads the space sensor and compares the temperature to the current heating set point. The zone controller then calculates the required supply air temperature (submaster reference temperature) to satisfy conditions. The calculated value is compared to the actual temperature supply air and the output is adjusted to satisfy conditions. The reference temperature is determined by comparing space temperature with the current biased heating set point.

A Proportional/Integral/Derivative (PID) loop is used whenever the mode is heating (occupied, unoccupied, or warm-up).

The heating PID loop maintains the current heating set point (configured value plus any offset from a 33ZCT56SPT sensor slide bar).

In a single duct terminal unit equipped with heating, the terminal will provide sufficient airflow for heating (greater of cooling minimum or reheat values) to the zone whenever heating is required, as determined by the space temperature sensor and the set point, if the equipment is supplying cool air. The reheat cfm is used to ensure that proper airflow across the heater is maintained, if the minimum cooling airflow is too low for safe heating operation.

NOTE: In a system, when the central air source fan is operating (detected by the linkage master zone controller) ducted heat will be available to operate.

The zone controller performs reheat when the space temperature in its zone is below the heating set point and the air source is delivering cooled air.

During this process, the zone controller also uses the temperature deviation from the heating set point in a PID calculation to determine a supply-air temperature which will satisfy the heat demand in the space.

COOLING ONLY — Fig. 6 shows the hardware configuration for a zone controller applied to a single duct air terminal that is not equipped with heat. The diagram in Fig. 7 shows how the zone controller controls this type of air terminal. The terminal provides cooling by modulating its primary air damper.

A single duct air terminal without local heat can only perform heating functions while its air source is delivering heated air. The control sequence for heating is similar to that for cooling. When the space temperature is below the Heating set point, the air source is in the heat mode, and VAV heating is enabled, the zone controller modulates the air terminal's damper to provide supply airflow between minimum and maximum heating CFM. A temperature PID loop that maintains space temperature determines the airflow set point. As the space temperature goes above the heating set point, the PID loop will start to reduce the airflow.

As with cooling operation, the standard heating mode is the same for occupied and unoccupied periods, differing only in the set point that the zone controller uses.

Damper Override supersedes the cfm setting the zone controller would otherwise maintain based on space temperature. The smoke control panel that commands the override mode must be in accordance with local codes.

STAGED ELECTRIC HEAT — The zone controller can be configured to control up to three stages of electric heat. The heat source can be installed in the air terminal (ducted), or as perimeter heat. Fig. 8 shows the hardware configuration for a zone controller applied to a single duct air terminal equipped with ducted staged electric heat. The diagram in Fig. 9 shows how the zone controller controls this type of air terminal.

The figures depict the electric heat source installed in the air terminal. When the zone controller is used to control perimeter heat it follows the same control routines that it uses for terminal heat. Heat is used in two ways. Heat operates when the zone controller's zone requires heating and the air source is supplying cool air to satisfy cooling demand in other zones (reheat). Heat can also be energized to supplement air source heating while the air source is supplying heated air.

Staged (electric) heating (1 or 2 stages) is provided by the 33ZCVAVTRM zone controller. Staged (electric) heating (3 stages) is provided by the 33ZCFANTRM zone controller. The staging function compares the submaster reference with the supply-air temperature to calculate the required number of outputs to energize

The percent output capacity for electric staged heat control is calculated and displayed.

HOT WATER OR STEAM HEAT — The zone controller can be configured to control local heat provided by heating coils carrying hot water or steam, governed either by a two-position (on/off) valve or by a proportional (floating modulating) valve. The heating coils can be installed in the air terminal (ducted), or as perimeter heat. Figure 10 shows the hardware configuration for a zone controller applied to a single duct air terminal equipped with ducted hot water or steam heating coils. The diagram in Fig. 11 shows how the zone controller controls an air terminal equipped with two-position hot water or steam heat. The diagram in Fig. 12 shows how the zone controller controls an air terminal equipped with proportional hot water or steam heat.

The figures depict the heating coils installed in the air terminal. When the zone controller is used to control perimeter heat it follows the same control routines that it uses for terminal heat. Modulating perimeter heating must be hot water, but two-position may either be hot water or steam heat.

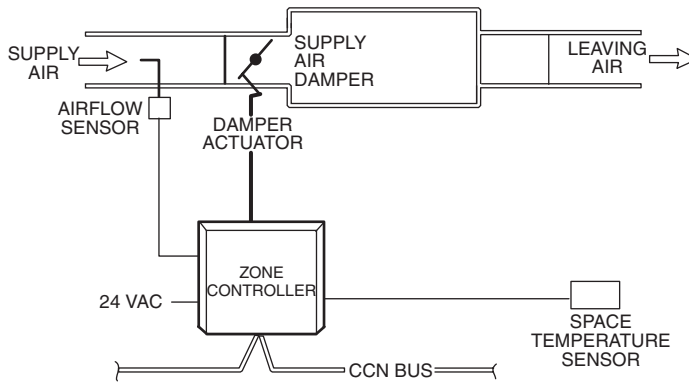
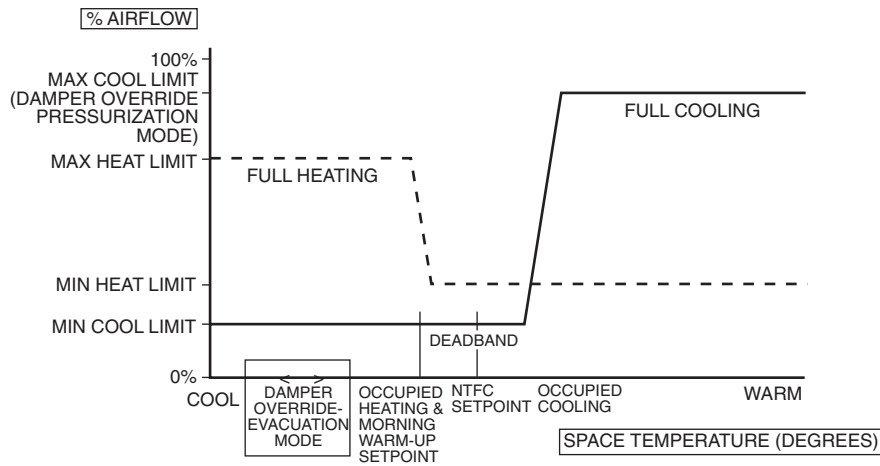
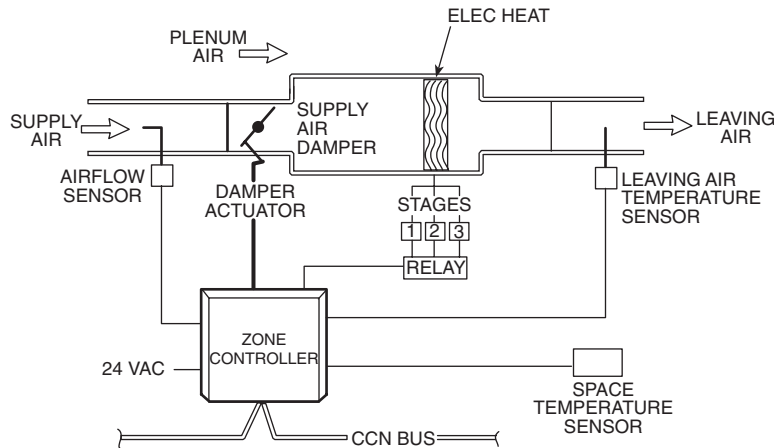

Fig. 6 — Single Duct Air Terminal — Cooling-Only



LEGEND
 - - - - Air Source Supplying Heated Air
 ———— Air Source Supplying Cooled Air

Fig. 7 — Sequence of Operation for Single Duct Air Terminal — Cooling-Only



NOTE: For 1 or 2 stage heat — use 33ZCVAVTRM.
 For 3 stage heat — use 33ZCFANTRM.

Fig. 8 — Single Duct Air Terminal with Staged Electric Heat

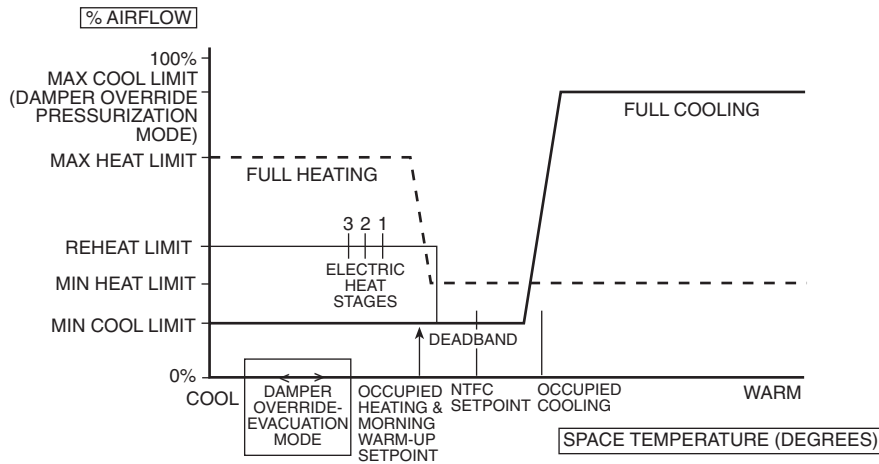

LEGEND

- Air Source Supplying Heated Air and Zone Controller is Configured for Central Heating Only
- Air Source Supplying Cooled Air

Fig. 9 — Sequence of Operation for Single Duct Air Terminal with Staged Electric Heat

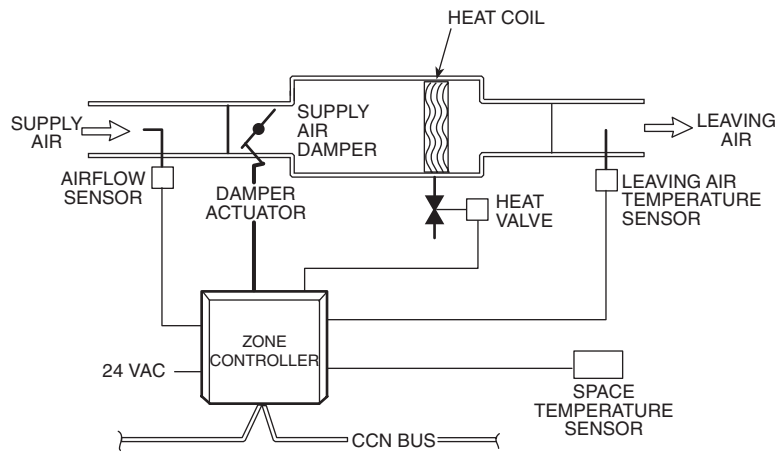
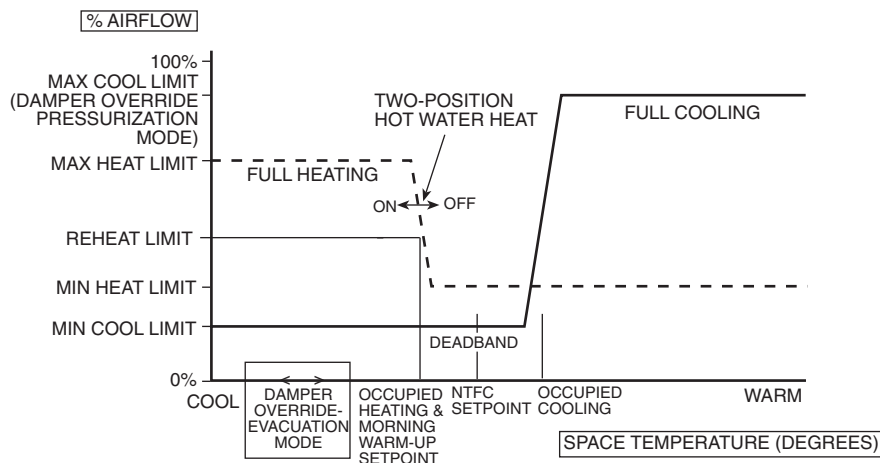

Fig. 10 — Single Duct Air Terminal with Hot Water or Steam Heat



LEGEND

- Air Source Supplying Heated Air
- Air Source Supplying Cooled Air

Fig. 11 — Sequence of Operation for Single Duct Air Terminal with Two-Position Hot Water or Steam Heat

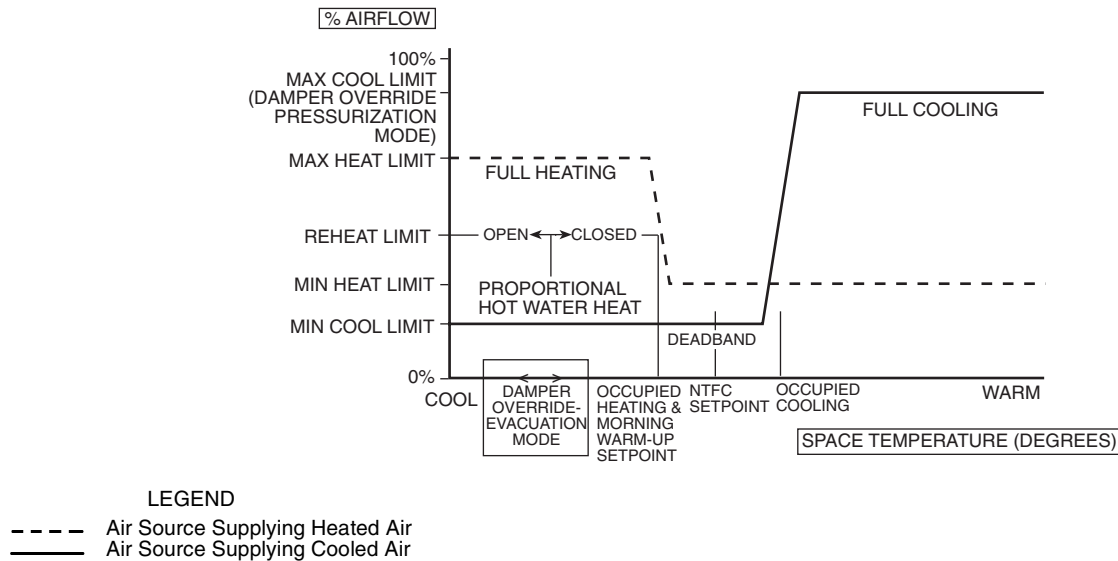

Fig. 12 — Sequence of Operation for Single Duct Air Terminal with Proportional Hot Water or Steam Heat

For modulating control, the supply air needed is compared to the actual supply air to either drive the valve open or closed. There is a deadband on the supply air deviation where the valve will be left at the current position until the error gets larger than the deadband.

For modulating type heat, the floating point function compares the submaster reference from the PID loop to the supply air temperature to calculate the direction and time to position the valve. The control prevents both outputs from operating simultaneously.

Configuration determines the logic output type for normally open or normally closed type two-position valves. Hysteresis is determined by the Heating Proportional Gain configured.

Heating with IAQ Control — A feature is provided for situations in which additional primary air is required for ventilation (IAQ).

The heating set point is calculated as the midpoint between the current heating and cooling set points.

The standard heating algorithm is used except the control set point is raised. The algorithm prevents the space temperature from falling below the set point before heating is activated. The air terminal must be in the cooling mode and the equipment must be providing cooling.

33ZCFANTRM VAV Zone Controller Information — The zone controller will control the operation of the fan (start and stop), whenever the zone controller is configured for use with a series or parallel fan terminal. The control algorithm determines the required fan state, based on the local mode, equipment mode, and the terminal type configuration.

For parallel or intermittent fan powered terminals (type 2 configuration), the fan operates as follows:

1. The fan is energized:
 - a. When ever $SPT < \text{current heating set point}$
 The primary air damper is set to the fully closed position if the air source mode is OFF and heating is required. After heating is disabled, or if the equipment begins to operate, the primary air damper returns to normal operation.
 - b. If the Primary Damper Reference drops below the configured Parallel Fan On value

2. The fan is deenergized:
 - a. Whenever $SPT > \text{current heating set point}$ and heating is disabled
 - b. If the Primary Damper Reference rises above the configured Parallel Fan ON value

For series or constant volume fan powered terminals (type 3 configuration), the fan operates as follows:

1. The fan is energized:
 - a. During occupied periods
 - b. Whenever $SPT < \text{current heating set point}$
 - c. Whenever the air source mode is not off

NOTE: Whenever the terminal fan transitions to ON, a fan start-up routine will run to ensure the fan rotates in the proper direction.
2. The fan is deenergized:
 - a. If in Unoccupied mode and heating is not required, or if the air source is off
 - b. during the fan start-up routine.

Series Fan Terminal Applications — In a series fan terminal, the fan is located in the primary air stream and, therefore, must be running in order to achieve proper airflow. The series fan terminal allows for a variable temperature, constant volume airflow. Maintaining constant volume airflow is not a function of the zone controller. The fan itself will maintain a constant airflow. Therefore, as the primary airflow is modulated to control temperature, more or less air will be induced from the return air plenum to maintain constant volume airflow.

The fan is turned on whenever the central air source is on, or whenever unoccupied heating is required. The zone controller will energize the fan. Since the fan is located in the primary air stream, the fan may be rotating even if the fan is not energized. Due to the nature of the fan blade geometry, the fan will actually rotate backwards. Energizing the fan motor while the blades are rotating backwards will cause the fan to run backwards. The zone controller handles this condition by closing the primary damper before starting the fan. Closing the damper will stop any airflow which may cause the fan to rotate in reverse. Once the fan is started, the damper will be controlled normally.

When the zone controller is controlling a series fan, if the air source transitions from OFF to any other mode, the zone controller will implement a series fan start-up sequence. In this sequence, the zone controller will cause the damper to be driven closed. Once the damper is closed, the zone controller will wait 30 seconds and then enable the fan. The zone controller will then allow the damper to modulate. Mode control will wait a number of minutes (between 0 and 20) before initiating the fan start-up sequence to prevent all series fan terminals from closing their dampers at once. The delay time is calculated from the zone controller's address and ensures that only two fans will be turned off at one time.

In a series fan terminal, the fan must be able to deliver the zone's rated airflow and must be running whenever the air source is operating.

The 33ZCFANTRM VAV Fan Zone Controller provides heating control in three different ways:

- positioning the primary air damper to a minimum airflow when the air source is in cooling mode to deliver maximum induced plenum air to the zone
- controlling an optional auxiliary heater mechanism to provide heating
- modulation of the primary air damper when the air source is in its heating mode (VAV Central Heating)

The 33ZCFANTRM VAV Fan Zone Controller supports three methods to control heating. These methods are as follows:

- two-position (on/off) control using a normally open or normally closed heating valve
- modulating control using a normally open or normally closed floating point heating valve
- modulating control using up to 3 stages of electric heat

The series terminal fan operates based upon the air source mode (when it is in an operating mode other than OFF) or if the zone needs unoccupied heating.

If the space temperature drops below the unoccupied heating set point, the terminal fan will start unless it is already running due to the air source operating. With unoccupied cooling, the terminal fan will only start after the air source starts, based on the average space temperature exceeding the average unoccupied cooling set point.

COOLING — The primary control function of zone controller is to provide cooling to the space by modulating the amount of supply airflow through its primary damper.

The Zone Controller uses pressure independent operation to control the amount of cool air entering the space. The control variable is terminal airflow. A PID temperature control loop determines the airflow set point needed to maintain space temperature at the cooling set point.

The set point is limited to a range of values that allow the air source to operate properly in the cooling mode. These configured limits are listed in the Installation Instructions for the zone controller. The minimum limit ensures that the sum of all air terminal minimum airflow requirements fall within the minimum cooling operating range of the air source. The maximum limit ensures that airflow will not increase above the maximum design value and that the noise level generated at this maximum airflow will be acceptable to the occupants of the zone.

The sequence of operation is as follows: when the space temperature is above the cooling set point and the air source is in the Cooling mode, the zone controller modulates the air terminal's damper to supply airflow between the control minimum and maximum cooling airflow limits. A PID temperature control loop that maintains space temperature determines the airflow set point. As the space temperature falls below the cooling set point, the PID loop will start to reduce the airflow.

When the space temperature drops and remains below the cooling set point, the zone controller will hold the airflow at minimum cooling limit.

In its standard operating mode the zone controller follows the same control sequence for cooling during both occupied and unoccupied periods. The zone controller's Occupancy schedule determines which set point the zone controller will use.

HEATING — There are two ways to use local heat. Heat operates when the zone controller's zone requires heat and the air source is supplying cool air to satisfy cooling demand in other zones. Heat is also used to supplement air source heating while the air source is supplying heated air, but the temperature is inadequate to maintain the desired set point.

If the space temperature in the zone falls below the zone controller's heating set point while the air source is supplying cooled air, the zone controller keeps the supply-air damper closed to the configured minimum cooling cfm. This enables plenum air, induced by the fan, to raise the space temperature of the zone.

A series fan powered air terminal without local heat can provide heating while its air source is delivering heated air. The control sequence for heating is similar to that for cooling, except that the heating set point is used.

When the space temperature is below the Heating set point and the air source is in the heat mode, the zone controller modulates the air terminal's damper to supply airflow between minimum and maximum heating CFM (if configured for VAV central heating). A space temperature PID loop determines the airflow set point. As the space temperature rises above the heating set point, the PID loop will reduce the airflow.

As with cooling operation, the standard heating mode is the same for occupied and unoccupied periods, differing only in the set point that the zone controller works to satisfy. The zone controller turns on the air terminal's fan while working to satisfy the unoccupied heating set point.

The zone controller provides heat when the space temperature in its zone is below the heating set point and the air source is delivering cool air. To accomplish this, the zone controller closes its air terminal's supply-air damper to the configured minimum cooling cfm.

During this process, the zone controller also uses the temperature deviation from the heating set point in a PID calculation to determine a supply-air temperature which will satisfy the heat demand in the space (for optional ducted heat). If the supply air is not warm enough, another control loop calculates the required amount of heat to energize.

The configured Heat On Delay must expire (except if heat is energized during the Commissioning mode) before any mechanical heat is energized. The fan is energized (on) when the terminal is occupied and any time a call for heat from the space occurs during Unoccupied mode.

If VAV central heating is enabled, the PID loop that controls space temperature will maintain the current heating set point (configured value plus any offset from a 33ZCT56SPT sensor slide bar) whenever the central equipment is heating. It will modulate the damper between the minimum and maximum heating limits in order to maintain the desired heating set point.

When in unoccupied heating, the terminal's fan will be turned on to provide airflow to the zone. Also, in the unoccupied mode, the primary damper will be held in its last commanded position. If the air source becomes active (on) during this mode, the damper will be controlled normally.

NOTE: In a Linkage system, when the central fan is operating, the terminal fan will also be running.

COOLING WITH FAN — Figure 13 shows the hardware configuration for a zone controller applied to a series fan powered air terminal that is not equipped with local heat. The diagram in Fig. 14 shows how the zone controller controls this type of air terminal. The fan runs constantly in all modes during occupied periods.

STAGED ELECTRIC HEAT — The zone controller can be configured to control up to three stages of electric heat. The heat source can be installed in the air terminal (ducted), or as perimeter heat. Figure 15 shows the hardware configuration for a zone controller applied to a series fan powered air terminal equipped with staged electric heat. The diagram in Fig. 16 shows how the zone controller controls this type of air terminal. The fan runs constantly in all modes during occupied periods. During unoccupied periods the fan runs while the air terminal is operating to satisfy an unoccupied heating demand or if the air source is operating.

The percent output capacity for electric staged heat control is calculated and displayed.

Staged (electric) heating (1,2, or 3 stages), is provided by the 33ZCFANTRM zone controller. The staging function compares the submaster reference with the supply-air temperature to calculate the required number of outputs to energize.

HOT WATER OR STEAM HEAT — The zone controller can be configured to control local heat provided by heating coils carrying hot water or steam, governed either by a two-position (on/off) valve or by a proportional (floating modulating) valve. The heating coils can be installed in the air terminal (ducted), or as perimeter heat. If modulating baseboard is used, refer to the General Heating Information section for additional information. Figure 17 shows the hardware configuration for a zone controller applied to a series fan powered air terminal equipped with hot water or steam heating coils. The diagram in Fig. 18 shows how the zone controller controls an air terminal equipped with two-position hot water or steam heat. The diagram in Fig. 19 shows how the zone controller controls an air terminal equipped with proportional hot water or steam heat. The fan runs constantly in all modes during occupied periods.

For modulating control, the supply air needed is compared to the actual supply air to either drive the valve open or closed. There is a deadband on the supply air deviation where the valve will be left at the current position until the error gets larger than the deadband.

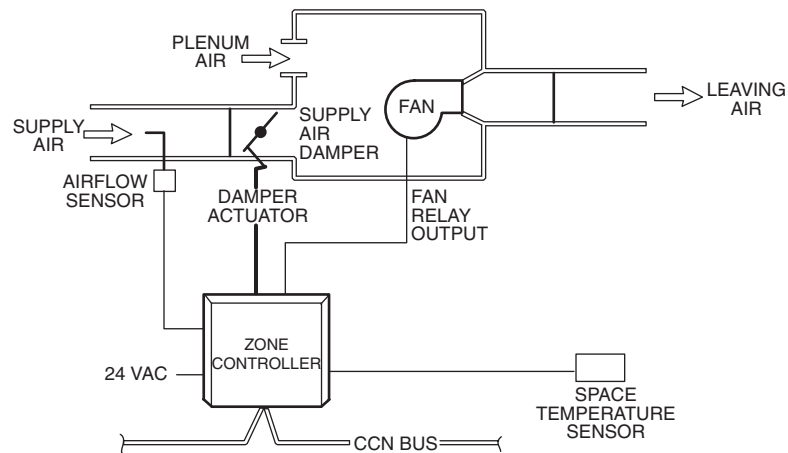

Fig. 13 — Series Fan Powered Air Terminal — Cooling-Only

For modulating type heat, the floating point function compares the submaster reference from the PID loop to the supply air temperature to calculate the direction and time to position the valve. The control prevents both outputs from operating simultaneously.

Configuration determines the logic output type for normally open or normally closed type two-position valves.

Heating with IAQ Control — A feature is provided for situations in which additional primary air is required for ventilation (IAQ).

The heating set point is calculated from the midpoint between the current heating and cooling set points.

The standard heating algorithm is used. The algorithm prevents the space temperature from falling below the set point before heating is activated. The air terminal must be in the cooling mode and the equipment must be providing cooling.

When in unoccupied heating, the terminal's fan will be turned on to provide airflow to the zone. Also, in the unoccupied mode, the primary damper will be held in its last commanded position. If the air source becomes active (on) during this mode, the damper will be controlled normally.

NOTE: In a Linkage system the when the central fan is operating, the terminal fan will also be operating.

Parallel Fan Terminal Applications — The parallel fan terminal provides three capabilities to the zone. First, it allows for unoccupied heating if auxiliary heating is available. Secondly, it allows CV heating when occupied (the fan is on when ducted heating is on). Thirdly, it provides a means to prevent cold air from “dropping” into the zone during cooling mode.

The 33ZCFANTRM VAV Fan Zone Controller provides heating control in three different ways:

- positioning the primary air damper to a minimum airflow when the air source is in cooling mode and starting the fan to utilize plenum heat as a first stage
- controlling an optional auxiliary heater mechanism to provide heating
- modulation of the primary air damper when the air source is in its heating mode (VAV Central Heating)

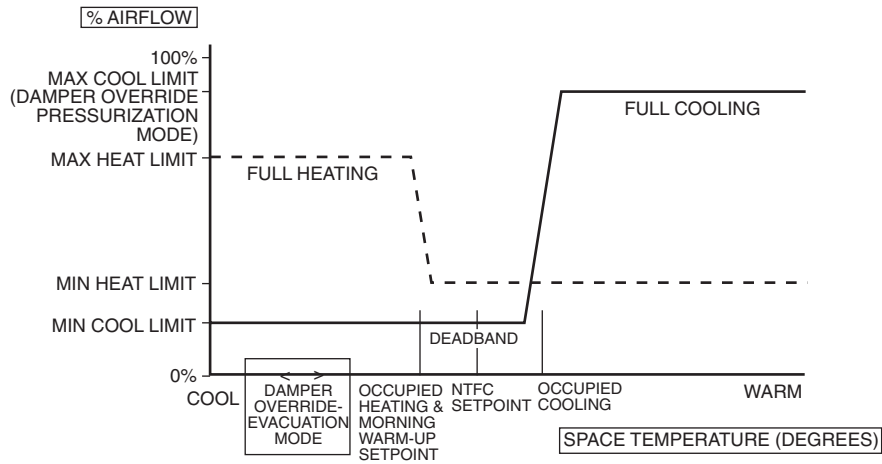

LEGEND
 - - - - Air Source Supplying Heated Air
 _____ Air Source Supplying Cooled Air

Fig. 14 — Sequence of Operation for Series Fan Powered Air Terminal — Cooling-Only

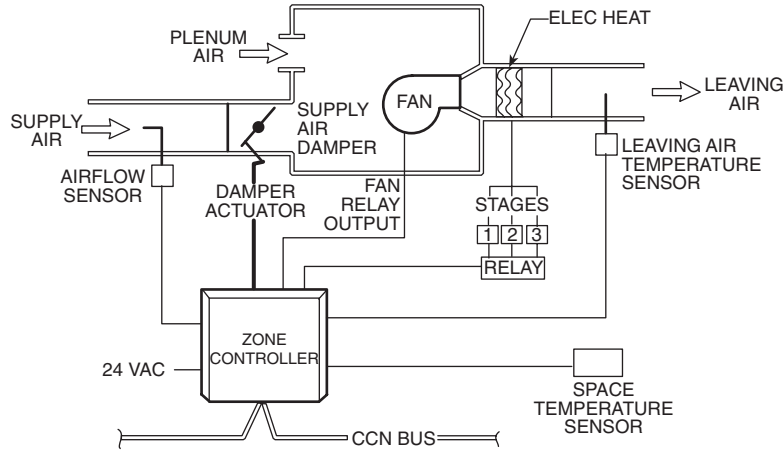
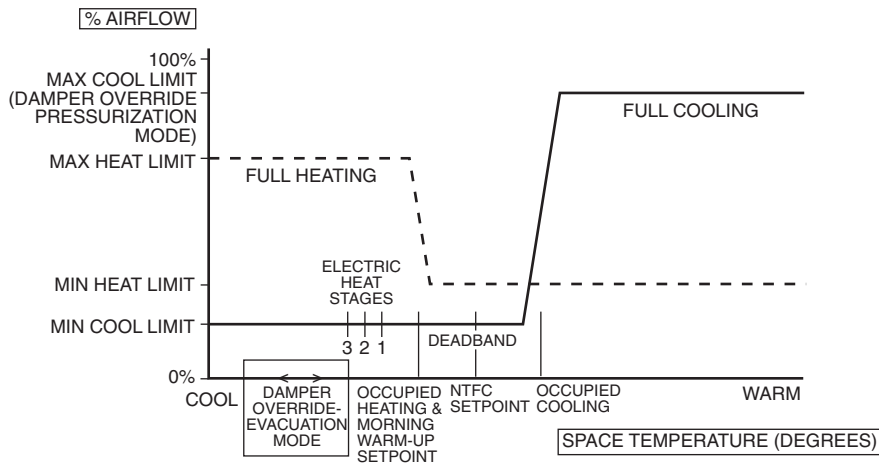

Fig. 15 — Series Fan Powered Air Terminal with Staged Electric Heat



LEGEND
 - - - - Air Source Supplying Heated Air
 _____ Air Source Supplying Cooled Air

Fig. 16 — Sequence of Operation for Series Fan Powered Air Terminal with Staged Electric Heat

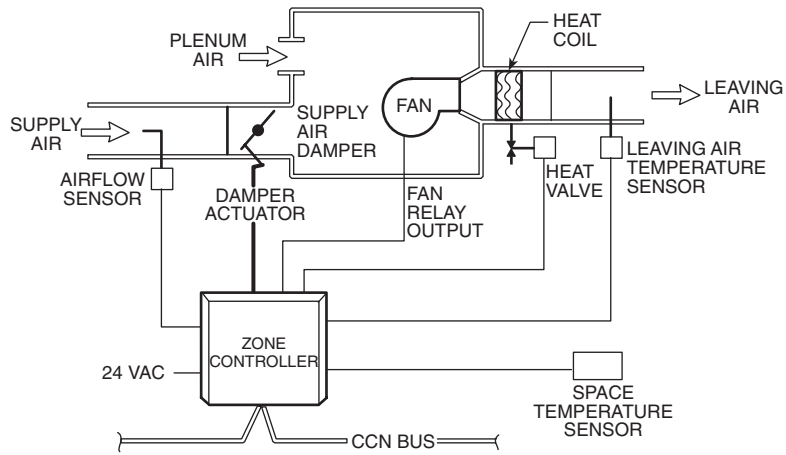
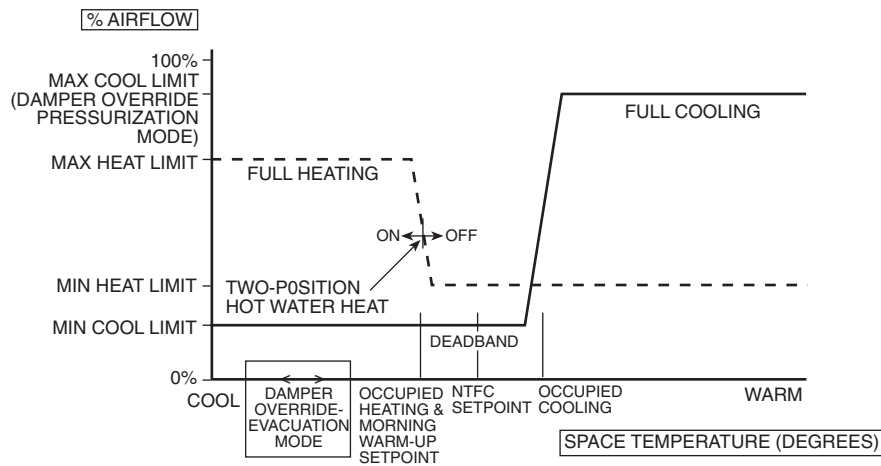

Fig. 17 — Series Fan Powered Air Terminal with Hot Water or Steam Heat



LEGEND

- Air Source Supplying Heated Air
- Air Source Supplying Cooled Air

Fig. 18 — Sequence of Operation for Series Fan Powered Air Terminal with Two-Position Hot Water or Steam Heat

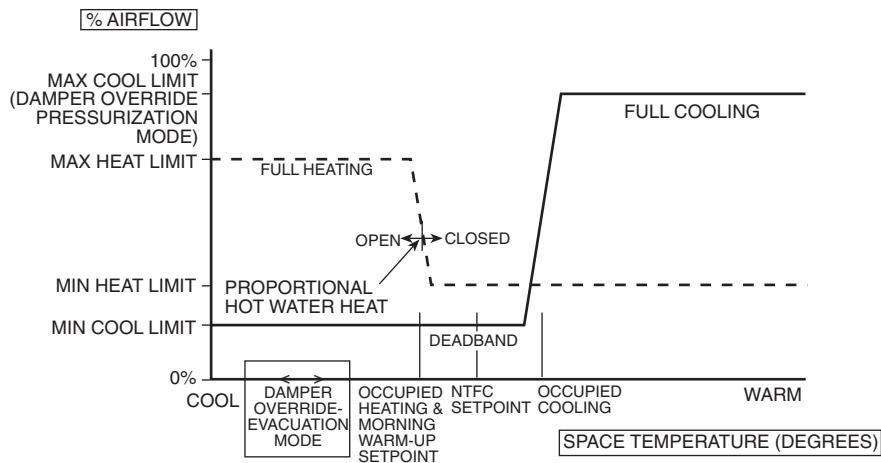

LEGEND

- Air Source Supplying Heated Air
- Air Source Supplying Cooled Air

Fig. 19 — Sequence of Operation for Fan Powered Air Terminal with Proportional Hot Water or Steam Heat

The 33ZCFANTRM VAV Fan Zone Controller supports three methods to control heating. These methods are as follows:

- two-position (on/off) control using a normally open or normally closed heating valve
- modulating control using a normally open or normally closed floating point heating valve
- modulating control using up to 3 stages of electric heat

COOLING — The primary control function of zone controller is to provide cooling to the space by modulating the amount of supply airflow through its primary damper.

The Zone Controller uses pressure independent operation to control the amount of cooled air entering the space. The control variable is terminal airflow. A PID temperature control loop determines the airflow set point needed to maintain space temperature at the cooling set point.

The airflow set point is limited to a range of values that allow the air source to operate properly in the Cooling mode. These configured limits are listed in the Installation Instructions for the zone controller. The minimum limit ensures that the sum of all air terminal minimum airflow requirements fall within the minimum cooling operating range of the air source. The maximum limit ensures that airflow will not increase above the maximum design value and that the noise level generated at this maximum airflow will be acceptable to the occupants of the zone.

The sequence of operation is as follows: when the space temperature is above the cooling set point and the air source is in the Cooling mode, the zone controller modulates the air terminal's damper to supply airflow between the minimum and maximum cooling airflow limits. A PID temperature control loop that maintains space temperature and determines the airflow set point. As the space temperature falls below the cooling set point, the PID loop will start to reduce the airflow. When the space temperature drops and remains below the cooling set point, the zone controller will hold the airflow at minimum cooling limit. If the minimum cooling set point is below the Parallel Fan On set point, the fan will operate to improve air circulation.

In its standard operating mode the zone controller follows the same control sequence for cooling during both occupied and unoccupied periods. The zone controller's Occupancy schedule determines which set point the zone controller will use.

There are two ways to use local heat. Heat operates when the zone controller's zone requires heat and the air source is supplying cool air to satisfy cooling demand in other zones. Heat can also be energized to supplement air source heating while the air source is supplying heated air, but the temperature is inadequate to maintain the desired set point.

HEATING — If the space temperature in the zone served by a parallel fan powered air terminal falls below the zone controller's heating set point while the air source is supplying cool air, the zone controller keeps the supply air damper closed to the configured minimum cooling cfm. It also turns on the fan to induce warmer plenum air.

A parallel fan powered air terminal without local heat can perform heating functions while its air source is delivering heated air. When the space temperature is below the heating set point and the air source is delivering heated air the zone controller turns on the fan to induce plenum air. The zone controller modulates the air terminal's damper to supply airflow between the minimum and maximum heating limits (if

configured for VAV central heating). A space temperature PID loop determines the airflow set point. As the space temperature rises above the heating set point, the PID loop will reduce the airflow. When heat is no longer required, the parallel fan will be turned off.

As with cooling operation, the standard heating mode is the same for occupied and unoccupied periods, differing only in the set point that the zone controller works to satisfy.

The zone controller provides heat when the space temperature in its zone is below the heating set point and the air source is delivering cool air. To accomplish this, the zone controller closes its air terminal's supply air damper to the configured minimum cooling cfm. This minimizes the cool air entering its zone from the air source. The fan is turned on to induce plenum air. The zone controller induces plenum air for a configurable length of time in an attempt to satisfy the heating set point without turning on local heat. The amount of time is determined by the Heat ON Delay parameter.

During this process, the zone controller also uses the temperature deviation from the heating set point in a PID calculation to determine a supply air temperature which will satisfy the heat demand in the space. If the heated air is not warm enough, another control loop calculates the required number of outputs to energize. For all terminals, the configured Heat ON Delay must expire (except if heat is energized during the Commissioning Mode) before any mechanical heat is energized.

If VAV central heating is enabled, the PID loop that controls space temperature will maintain the current heating set point (this is a configured value plus any offset from a 33ZCT56SPT sensor slide bar). Whenever the central equipment is heating, it will modulate the damper between the minimum and maximum heating limits in order to maintain the desired heating set point.

NOTE: When applied on a parallel fan type terminal, the zone controller will utilize the fan as the first stage of heat even if no heat is configured. The amount of time the fan will operate as the first heat stage is determined by the value configured for the Heat On Delay (10 to 20 minutes recommended).

COOLING ONLY — Figure 20 shows the hardware configuration for a zone controller applied to a parallel fan powered air terminal that is not equipped with heat. The diagram in Fig. 21 shows how the zone controller controls this type of air terminal. The fan runs while the air terminal is heating.

STAGED ELECTRIC HEAT — The zone controller can be configured to control up to three stages of electric heat. The heat source can be installed in the air terminal (ducted), or as perimeter heat. Figure 22 shows the hardware configuration for a zone controller applied to a parallel fan powered air terminal equipped with staged electric heat. The diagram in Fig. 23 shows how the zone controller controls this type of air terminal. The fan runs while the air terminal is heating.

The figures depict the electric heat source installed in the air terminal. When the zone controller is used to control perimeter heat it follows the same control routines that it uses for terminal heat.

The percent output capacity for electric staged heat control is calculated and displayed.

Staged (electric) heating (1,2, or 3 stages), is provided by the 33ZCFANTRM Zone Controller. The staging function compares the submaster reference with the supply-air temperature to calculate the required number of outputs to energize.

HOT WATER HEAT — The zone controller can be configured to control local heat provided by heating coils carrying hot water or steam, governed either by a two-position (on/off) valve or by a proportional (floating modulating) valve. The heating coils can be installed in the air terminal (ducted), or as perimeter heat. If modulating baseboard heat is used, refer to the General Heating Information section for additional information. Figure 24 shows the hardware configuration for a zone controller applied to a parallel fan powered air terminal equipped with hot water or steam heating coils. The diagram in Fig. 25 shows how the zone controller controls an air terminal equipped with two-position hot water or steam heat. The diagram in Fig. 26 shows how the zone controller controls an air terminal equipped with proportional hot water or steam heat. The fan runs while the air terminal is heating.

For modulating control, the supply air needed is compared to the actual supply air to either drive the valve open or closed. There is a deadband on the supply air deviation where the valve will be left at the current position until the error gets larger than the deadband.

Configuration determines the logic output type for normally open or normally closed type two-position valves.

Heating with IAQ Control — A feature is provided for situations in which additional primary air is required for ventilation (IAQ).

The heating set point is calculated from the midpoint between the current heating and cooling set points.

The standard heating algorithm is used. The effect is to prevent the space temperature from falling below the set point before heating is activated. The air terminal must be in the Cooling mode and the equipment must be providing cooling.

When in unoccupied heating, the terminal's fan will be turned on to provide airflow to the zone. Also, in the Unoccupied mode, a parallel fan terminal zone controller will keep the primary damper closed to prevent airflow back into the primary air duct. If the air source becomes active (on) during this mode, the damper will be controlled normally.

Static Pressure Reset

OVERVIEW — The static pressure reset function of the zone controller linkage master will automatically reset the central air source's supply-fan static pressure set point (downward) as a function of the zone damper position. This allows the system to automatically make adjustments to the static pressure and optimize performance of the central air source fan. The maximum pressure is determined by the set point configured at the equipment control. The minimum value is determined by the maximum value configured.

OPERATION — Once a minute, the linkage master examines the state of the air source fan. If the fan is operating, the position of each damper serviced by the air source is polled by the Linkage Master to determine the position of its dampers. If the fan is off, the algorithm calculates a value of 0 for the reset value.

With the fan operating, the static pressure function determines the maximum open damper in the system and compares that value to the configured reset minimum damper position. When all of the dampers are below (closed) the configured reset minimum damper position, the linkage master calculates a reset value.

The reset value is communicated to the fan controller in the air source once every minute. The central air source controller subtracts the reset value from the air source static pressure set point.

The central air source controller begins to modulate its fan volume control mechanism to maintain the new supply static pressure set point. Each zone controller modulates its terminal's damper position in order to provide the required pressure drop or restriction to maintain the zone's CFM balance point at this new supply duct pressure. If the static pressure set point value has been changed, then the linkage master will wait 2 minutes to allow the air source static pressure control to affect the system static pressure before calculating any further reset value. If the most open damper in the system is open greater than the maximum damper position, then the linkage master calculates a reduction to the previous reset value. This will result in an increase in static pressure (never greater than the configured set point).

NOTE: Primary air source controllers that support this function are the *AirManager*TM control. Comfort Controllers can support this function by using *Best++*TM applications available by contacting the local Carrier representative.

Indoor Air Quality (IAQ) Control — Each zone controller used in a single duct and fan powered application has the ability to provide IAQ operation. The IAQ function determines the zone ventilation airflow as a function of the IAQ zone sensor reading. When the air quality control is enabled, the zone controller will override (increase) the primary airflow in order to provide Demand Controlled Ventilation if the airflow is insufficient to meet the ventilation set point.

The control algorithm uses a P/I algorithm to determine the required airflow in order to prevent the IAQ sensor value from exceeding the desired Air Quality set point. The zone controller is designed to interface with the following IAQ sensors that sense CO₂:

The 33ZCSENCO2 sensor is an indoor, wall mounted sensor with an LED (light-emitting diode) display. The sensor has an analog output (0 to 10 vdc) over a range of 0 to 2000 ppm. An SPDT contact is provided to close at 1000 ppm with a hysteresis of 50 ppm.

The 33ZCT55CO2 sensor is an indoor, wall mounted sensor without display. The CO₂ sensor also includes a space temperature sensor with override button.

The 33ZCT56CO2 sensor is an indoor, wall mounted sensor without display. The CO₂ sensor also includes a space temperature sensor with override button and temperature offset.

The IAQ function contains a provision to operate modulating type heat, if required and supplied, to maintain the space temperature at the midpoint between the heating and cooling set points during IAQ operation. Operation is dependent upon the equipment mode of operation, so that the Air Quality function will only operate during Occupied periods when the outdoor air damper is actively providing ventilation. A user configured AQ Maximum % can be used to protect the zone from overcooling if local heating is not supplied. Air Quality control is automatically suspended if the space temperature falls below the heating set point. Air quality control will be disabled if the AQ sensor status fails.

Secondary Zone Controller (33ZCSECTRM) — The 33ZCFANTRM zone controller, in conjunction with the 33ZCSECTRM zone controller, can be used for zone pressure control and dual duct applications. To perform these functions a secondary damper and a secondary airflow sensor is required. The type of secondary airflow control (none, pressurization, or dual duct) is user selectable at each secondary zone controller.

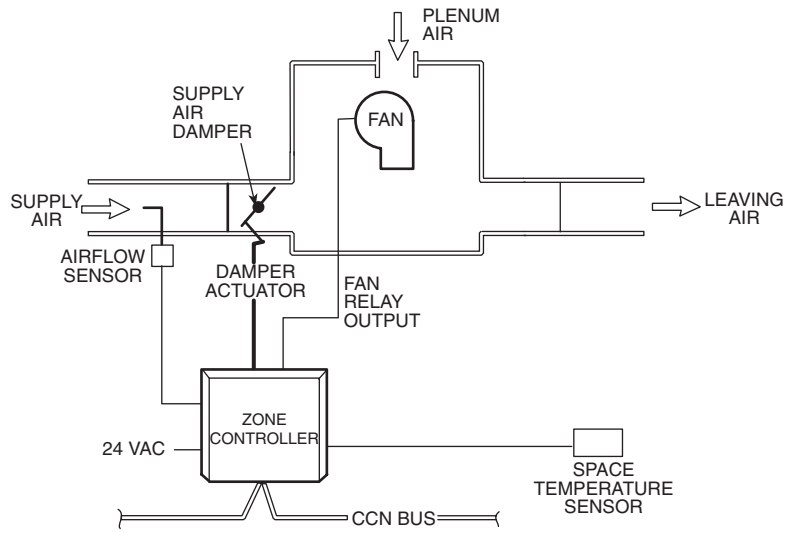
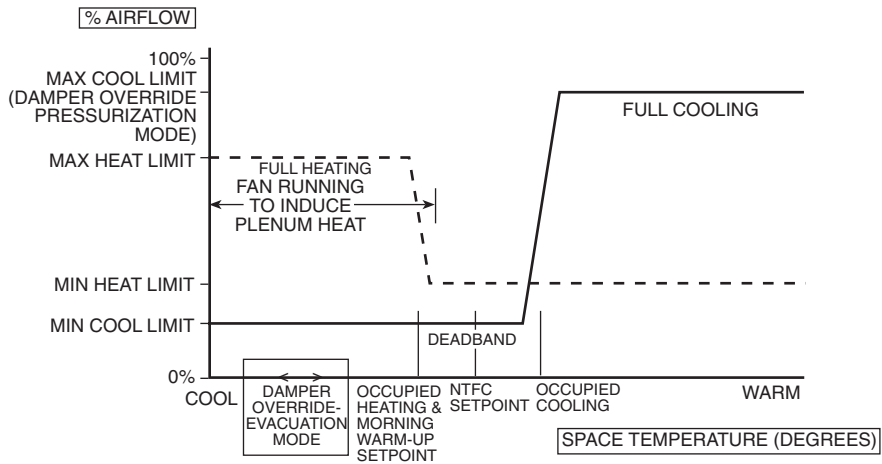

Fig. 20 — Parallel Fan Powered Air Terminal — Cooling-Only



LEGEND
 - - - - Air Source Supplying Heated Air
 _____ Air Source Supplying Cooled Air

Fig. 21 — Sequence of Operation for Parallel Fan Powered Air Terminal — Cooling-Only

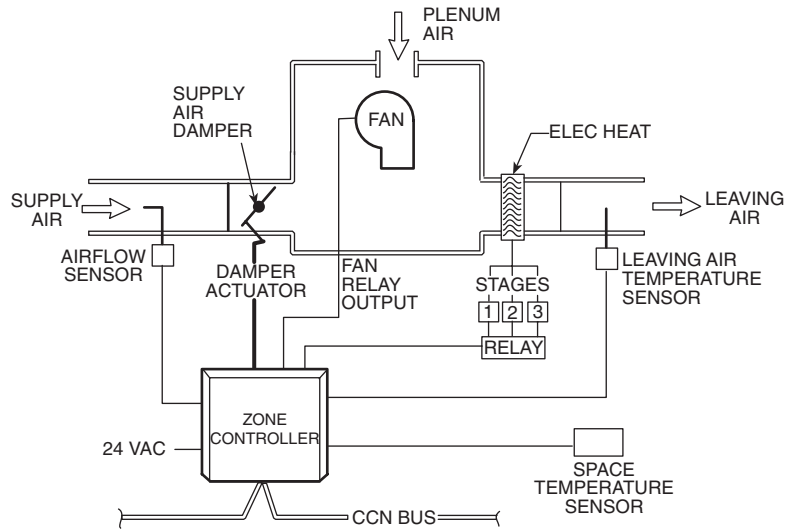
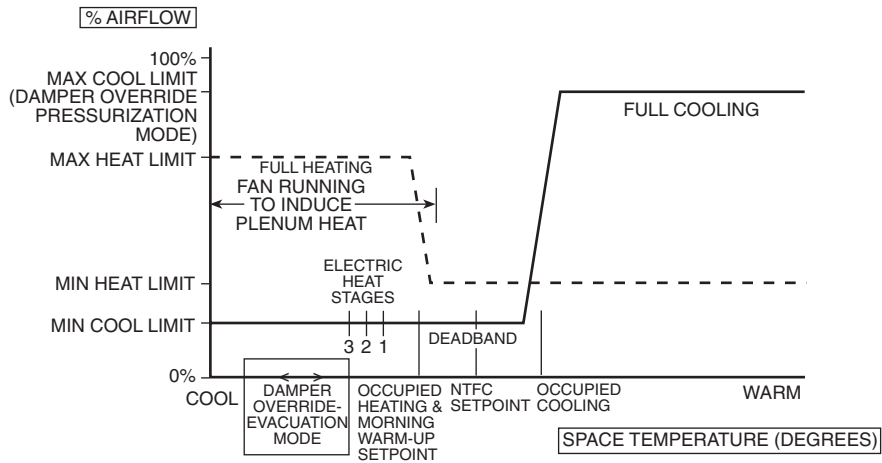

Fig. 22 — Parallel Fan Powered Air Terminal with Staged Electric Heat



LEGEND
 - - - - Air Source Supplying Heated Air
 ——— Air Source Supplying Cooled Air

Fig. 23 — Sequence of Operation for Parallel Fan Powered Air Terminal with Staged Electric Heat

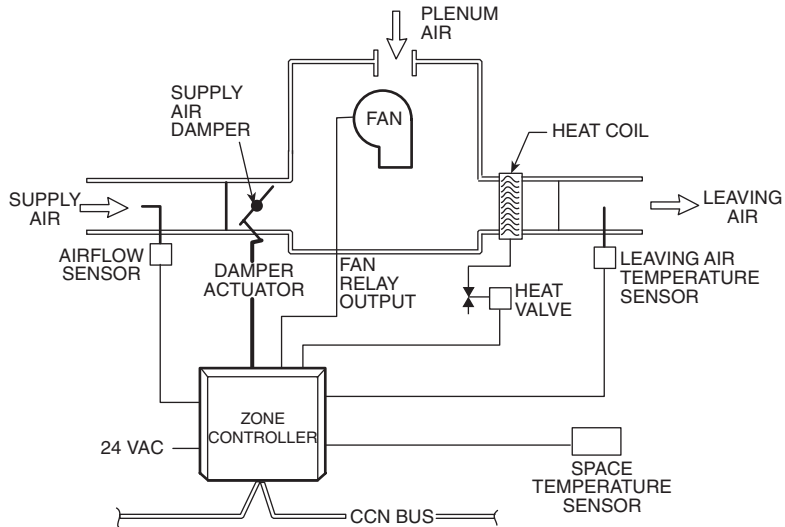
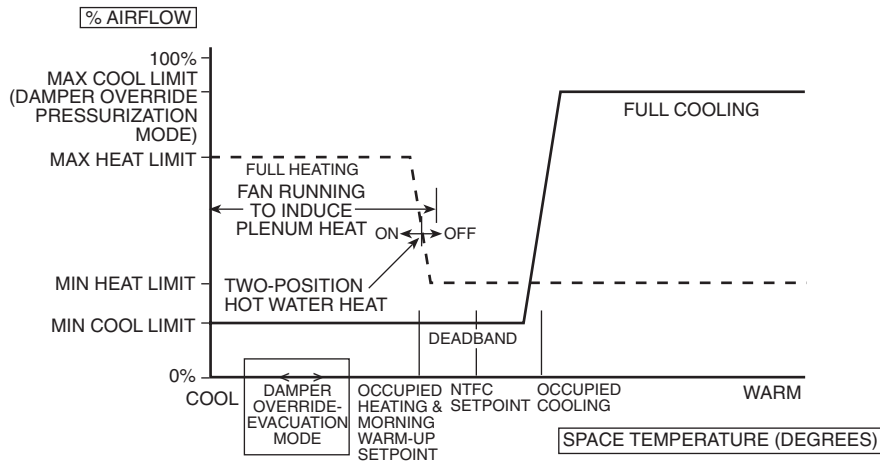
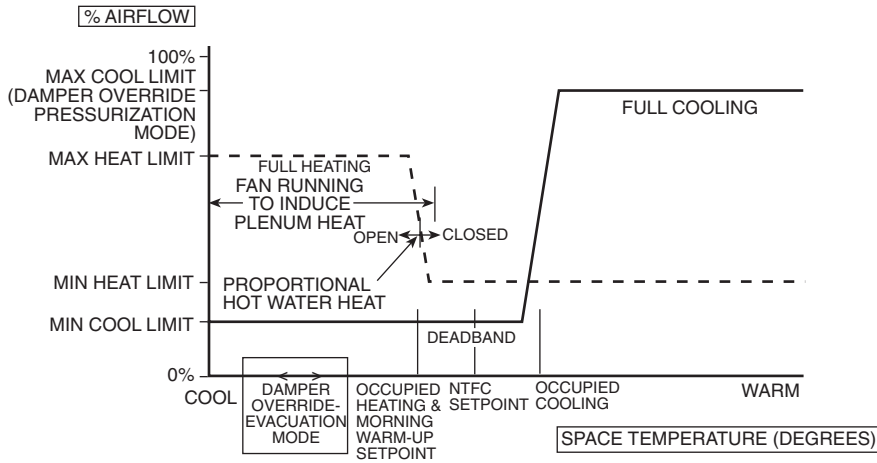

Fig. 24 — Parallel Fan Powered Air Terminal with Hot Water or Steam Heat



LEGEND
 - - - - Air Source Supplying Heated Air
 _____ Air Source Supplying Cooled Air

Fig. 25 — Sequence of Operation for Parallel Fan Powered Air Terminal with Two-Position Hot Water or Steam Heat



LEGEND
 - - - - Air Source Supplying Heated Air
 _____ Air Source Supplying Cooled Air

Fig. 26 — Sequence of Operation for Parallel Fan Powered Air Terminal with Proportional Hot Water or Steam Heat

Zone Pressure Control (Terminal Tracking)

GENERAL — The 33ZCFANTRM controller can provide zone pressure control through the use of the accessory 33ZCSECTRM secondary damper terminal control. The secondary terminal control utilizes the same actuator, enclosure, and airflow sensor as the 33ZCFANTRM. The secondary terminal controller directly connects to the return air damper for the control zone. The main purpose of this application is to provide proper pressure control in the zone while providing thermal comfort for the occupants of a zone. The supply-air damper is modulated in order to maintain the space temperature set points. As the supply airflow changes, the pressure control modulates the return airflow to maintain a fixed delta (positive or negative) from the current supply. This ensures proper zone pressurization.

This method of pressure control is known as volumetric flow tracking. This method of control measures the exhaust and supply airflow and controls the amount of exhaust air to maintain the desired pressure differential. Volumetric control requires that each supply and exhaust point in the zone be controlled. It does not recognize or compensate for unquantified disturbances such as stack effects, infiltration, influences of other systems in the buildings. Flow Tracking is essentially independent of room door operation. Balancing is critical and must be addressed across the operating range.

The zone controller will provide zone pressure by controlling both the primary airflow into a zone and the return airflow

from the zone. This application utilizes a single duct terminal for space temperature control. This terminal can be equipped with auxiliary heat, either ducted or non-ducted. The supply terminal controls and monitors the volume of air entering the space during temperature, ventilation, or humidity control. The return air terminal controls the volume of air returning from the space. It is installed in the return air path from the zone. A secondary damper control is installed on this terminal and connected to the supply air terminal controller. Through the use of a secondary damper and an airflow sensor, the zone is maintained at a constant desired pressure (either negative or positive), by modulating the return airflow from the zone. The return airflow shall be controlled to an airflow set point that is offset from the current primary (supply) airflow set point by a configured delta. If the secondary airflow set point is less than the primary airflow set point, more air will flow into the zone than leaves the zone and the zone will be maintained at a positive pressure. If the secondary airflow set point is greater than the primary airflow set point, then more air will leave the zone than is entering it and the zone will be maintained at a negative pressure. As the zone's load changes and the primary damper modulates to maintain the desired temperature set point, the zone controller will modulate the secondary damper position to maintain the required differences in airflow and hence maintain the zone's static pressure. This zone configuration is shown in Fig. 27.

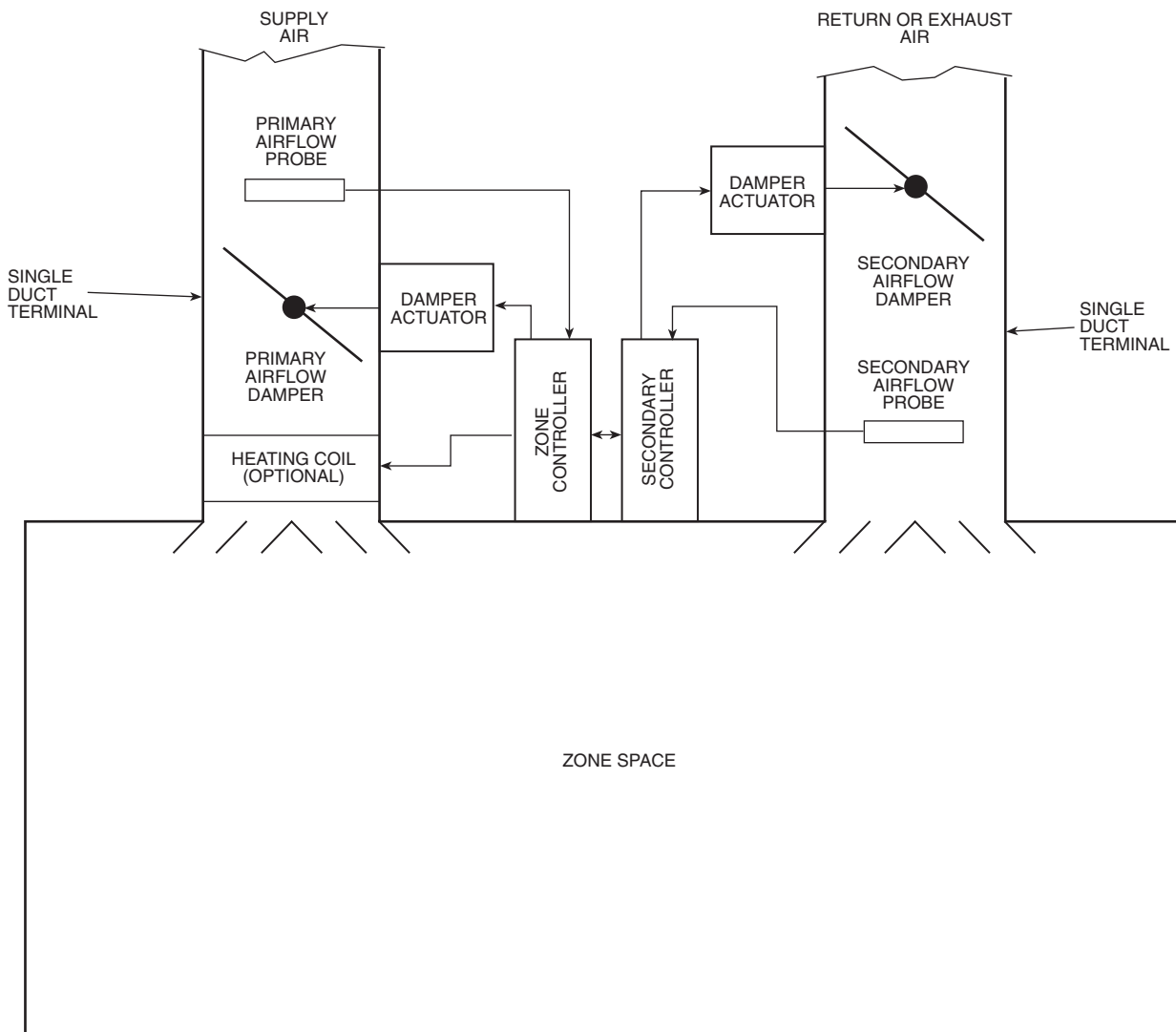

Fig. 27 — Secondary Damper for Zone Pressurization

Zone Pressure control can also be used to control systems utilizing dual duct terminals to supply a constant amount of ventilation air to each zone. In these systems, a separate ventilation air source delivers conditioned, ventilation air to the secondary inlet of each dual duct terminal. The primary inlet is connected to a standard VAV air source. The primary airflow is controlled to maintain the desired space temperature in the same way as a single duct terminal. A secondary airflow sensor is installed in the total airflow from terminal and connected to a secondary damper control. The actuator is installed on the secondary damper (hot deck or ventilation inlet). As the load changes and the primary airflow modulates, the airflow sensed by both the primary inlet and total outlet probes vary. If a negative value in the amount of the required ventilation airflow is configured, that difference is introduced by the secondary damper as ventilation air. In these applications, heating is typically provided by an auxiliary heat source controlled by the terminal, but may be supplied through the air source as well (VAV heating). See Fig. 28.

LIMITATIONS — The zone controller can not be located in corrosive and contaminated environments. The terminal controller maximum size damper is limited to 500 sq in. and 9000 CFM. Applying the zone controller in this manner for zone pressure control will work only if all the air entering the zone is measured. Therefore all the air supplied to the space must be supplied through a single duct type terminal. This is the same for the return zone exhaust air. Only single duct terminals or exhaust dampers can be controlled by a secondary terminal control. The 33ZCFANTRM zone controller and 33ZCESECTRM secondary damper terminal control must be configured for single duct control. The type of supply and exhaust damper do not need to be the same design and stroke (i.e., opposed blade, 90 degree butterfly, or 35 / 45 degree blade type).

To maintain a zone at a constant desired pressure (either negative or positive), the zone controller modulates the secondary damper to control the return airflow from the zone. The return airflow is controlled to an airflow set point that is offset from the current primary damper airflow set point by a configured delta. If the secondary airflow set point is less than the primary airflow set point, more air will flow into the zone than leaves the zone and the zone will be pressurized.

If the secondary airflow set point is greater than the primary set point, then more air will leave the zone than is entering it

and the zone will be depressurized. As the zone's temperature load changes and the primary damper modulates to maintain the desired temperature set point, the zone controller will modulate the secondary damper position to maintain the required difference in airflow and maintain the zone's static pressure.

TERMINAL TRACKING — For applications where pressure control is required in the occupied space in order to provide isolation, zone pressure control provides volumetric flow tracking to maintain the proper return airflow by controlling a secondary damper connected to the return air system. See Fig. 27. Zone Pressure Control can only work properly if all the air entering and leaving the space is measured. Therefore all air supplied to the space should be supplied through a single duct type terminal. No provision can be made to disable pressure control if other than a single duct terminal (fan powered terminal) is configured as the primary air device. In these systems, the primary air damper is modulated in order to maintain the space temperature within the desired set points. The primary air terminal is a single duct terminal, therefore all sequences of operation, for a single duct terminal apply to the primary terminal.

Only single duct type terminals should be used for return air control. If other terminals are used, no provision can be made to disable pressure control. As the primary airflow set point changes, the pressure control modules the return damper to maintain the secondary airflow at a fixed delta (either positive or negative) from the current primary airflow reference.

Dual Duct Terminal Applications — The zone controller provides control of a second damper in a dual duct terminal. A dual duct terminal has two primary air inlets, referred to as the cold deck and the hot deck. The second damper is the hot deck damper. The dampers are controlled by the 33ZCFANTRM and 33ZCESECTRM zone controllers. The two inlets provide a source of heating and cooling to the zone. Dual duct terminals can be controlled in a constant volume mode or a variable volume mode. Additionally, the constant volume mode can be controlled using a second inlet airflow probe or a total airflow probe. These three configurations are shown in Fig. 29-31. The main difference between the configurations is the placement of sensors and output control signals.

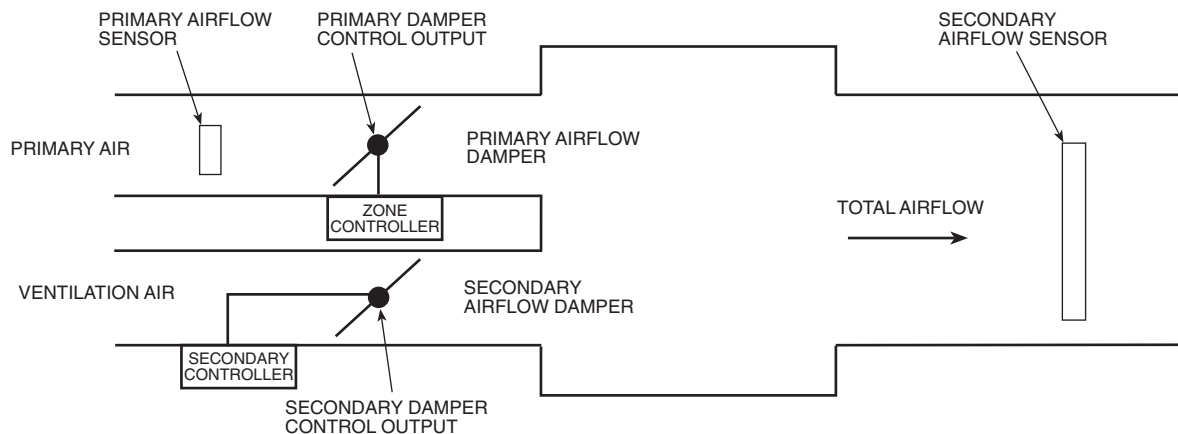

CONSTANT VENTILATION USING DUAL DUCT TERMINAL WITH ZONE PRESSURE CONTROL

Fig. 28 — Secondary Damper for Zone Pressurization

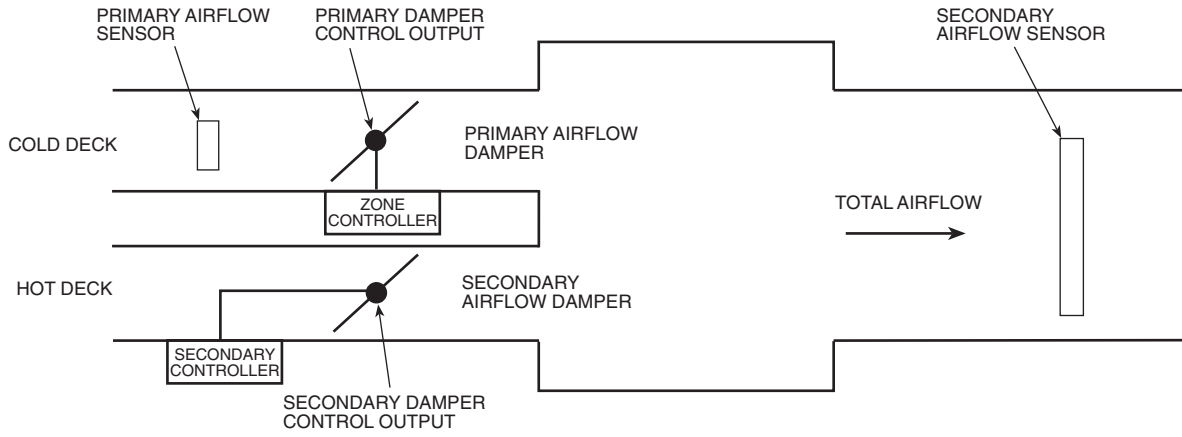

Fig. 29 — Constant Volume (Total Airflow Probe) Dual Duct

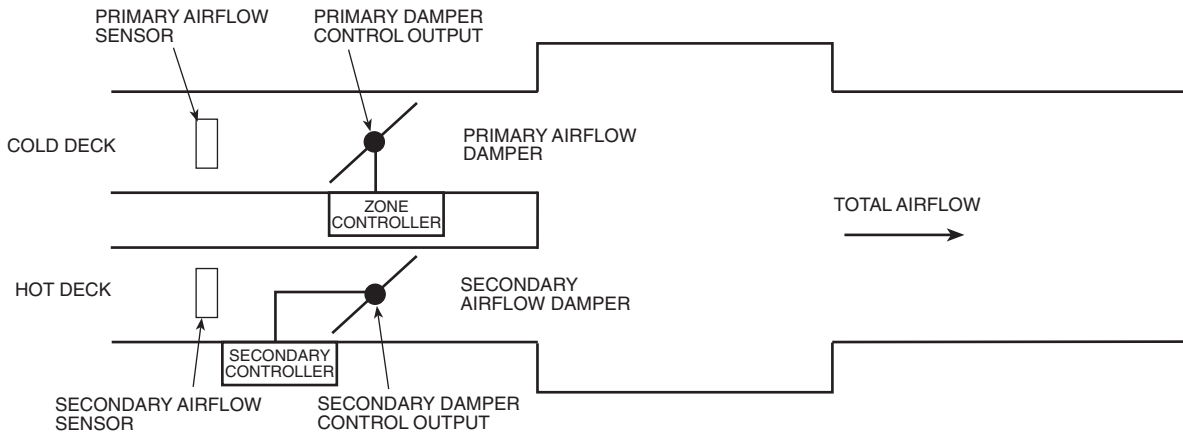

Fig. 30 — Constant Volume (Secondary Airflow Probe) Dual Duct

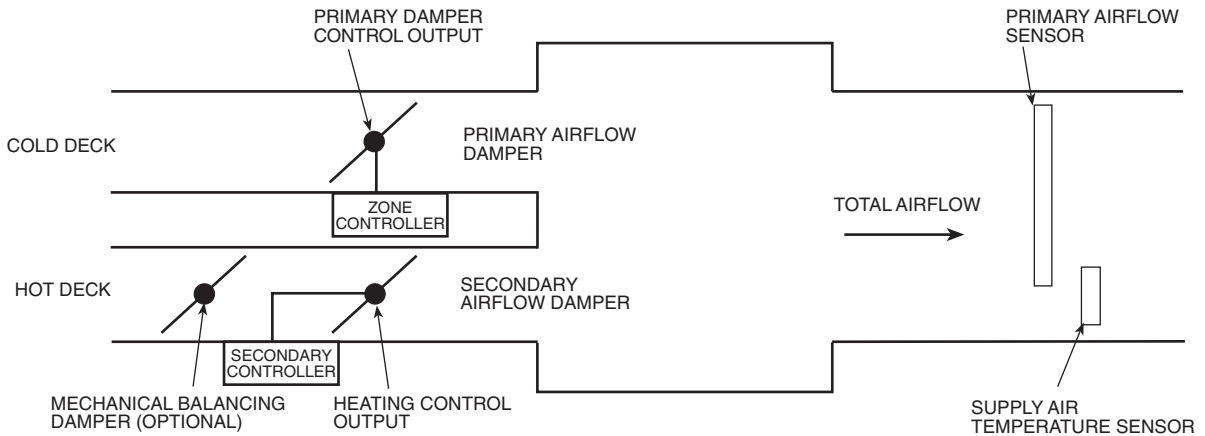

Fig. 31 — Variable Volume Dual Duct

The constant volume, dual duct terminals are controlled to provide constant volume, variable temperature airflow. The primary damper position is modulated to control space temperature in the same manner as a single duct terminal. The primary airflow sensor is placed in the cold deck inlet. The secondary damper position is modulated so that the total airflow is maintained at the configured set point. In the secondary airflow probe configuration, the secondary airflow sensor is placed in the hot deck inlet and the secondary damper position is modulated so that the secondary airflow equals the difference between the total CFM set point and the primary airflow. In the total airflow probe configuration, the secondary airflow sensor is placed in the total airflow stream and the secondary damper position is modulated so that the total airflow equals the total CFM set point.

CONSTANT VOLUME DUAL DUCT APPLICATIONS — Two ducts are used to supply air to the air terminal units. One is used to deliver cool, dehumidified air when the refrigeration system is operating. The other inlet will deliver warm air, which may either be heated air or return air from the conditioned space during warm weather. Perimeter, non-ducted heat can be used during the summer cooling season to better control humidity. The volume of cool and warm air circulated throughout the VAV system varies in relation to the changing ratio of cooling and heating loads. The 33ZCFANTRM and 33ZCSECTRM zone controllers are required.

This function controls the secondary damper to maintain constant volume airflow at the outlet of the terminal. There are two modes of operation for constant volume dual duct control based on where the secondary airflow sensor is placed. The placement of the sensor changes the control point. If the secondary airflow sensor is placed to measure the total airflow of the terminal, then the control point is configured for dual duct constant volume airflow. See Fig. 29. If the secondary airflow sensor is placed to measure the airflow in the secondary duct only, then the control point is calculated as follows: Control Point = Dual Duct Constant Volume Airflow – Primary Airflow Control Point. See Fig. 30.

VARIABLE VOLUME DUAL DUCT APPLICATIONS — The variable volume, dual duct terminals are controlled to provide variable volume, variable temperature airflow. For cooling, the terminal is controlled as a single duct terminal with the primary airflow sensor in the primary inlet. If maintaining the minimum cooling airflow at the terminal is desirable, then the probe location is acceptable. If it is desirable to decrease the minimum cooling airflow to zero during maximum heating, then the probe should be installed to sense total airflow. The 33ZCFANTRM and 33ZCSECTRM zone controllers are required.

In Cooling mode, the secondary damper will be closed. For heating, the zone controller will treat the secondary damper as an auxiliary, modulating heat source. This is accomplished by connecting the heating control output to the secondary damper actuator and allowing the heating control function to modulate the secondary damper position. As the heating output increases the secondary (hot deck) airflow, the primary airflow (cold deck) is reduced in order to maintain the minimum cooling or reheat airflow set point. Therefore the secondary damper position is controlled by a temperature control loop rather than an airflow control loop. In this configuration, the secondary airflow sensor is not used. See Fig. 31.

→ **Dehumidification Control Function** — Each zone controller is capable of providing a dehumidification routine for single duct and fan terminal applications. When the dehumidification function is configured in a zone controller, and the mode is Cooling, the zone controller will override (increase) the primary airflow in order to prevent the space relative humidity level from exceeding the desired Maximum Relative Humidity set point. The zone controller increases the airflow to displace the humid air in the space and replace it with primary air, which has a lower dew point temperature (less moisture).

During unoccupied periods, if relative humidity exceeds the unoccupied relative humidity set point, the zone controller initiates one hour of timed override. At the end of one hour, if relative humidity is still above the unoccupied set point, another hour of timed override is initiated. During the timed override, the zone controller follows all occupied set points. Timed override resulting from relative humidity control does not add to tenant billing time.

The zone controller will activate heating when the space temperature falls below the occupied heating set point. The Dehumidification mode becomes inactive when heating becomes active. The Dehumidification mode does not provide simultaneous heating and cooling.

The dehumidification algorithm uses a P/I algorithm to determine the required airflow. Zone controller dehumidification operation is dependent upon the equipment mode of operation. Dehumidification will only operate when heating is not active. A user-configured maximum output value (%) can be used to limit the amount of primary air that is supplied to the space while providing dehumidification. Dehumidification is disabled if the RH sensor status fails.

NOTE: It is recommended that auxiliary heat be used for all zones where humidity control is desired.

GUIDE SPECIFICATIONS

Zone Controller

Part Numbers:

33ZCFANTRM — VAV Fan Terminal Zone Controller
33ZCVAVTRM — Single Duct Air Terminal Zone Controller
33ZCSECTRM — Secondary Terminal Zone Controller

Part 1 — General

1.01 SYSTEM DESCRIPTION:

The zone controller is a single duct, fan powered, Variable Air Volume (VAV) terminal control with a factory-integrated controller and actuator. The zone controller maintains precise temperature control in the space by operating the terminal fan and regulating the flow of conditioned air into the space. Buildings with diverse loading conditions can be supported by controlling reheat or supplemental heat.

The Single Duct Air Terminal Zone Controller (33ZCVAVTRM) provides dedicated control functions for single duct terminals with modulating heat or up to 2 stages of heat.

The VAV Fan Terminal Zone Controller (33ZCFANTRM) provides dedicated control functions for series fan or parallel fan powered terminals, single duct terminals with 3 stages of heat, or as a primary controller for dual duct or zone pressure control applications.

When the VAV Fan Terminal Zone Controller is used in conjunction with a secondary terminal and the 33ZCSECTRM secondary terminal zone controller, either dual duct or zone pressurization applications can be supported.

1.02 QUALITY ASSURANCE:

- A. The control shall be UL or ETL listed to comply with UL Standard 873; Temperature Indicating and Regulating Equipment, and UL916-PAZX; Energy Management.
- B. The control shall meet ASHRAE standard, 62-1989 “Ventilation For Acceptable Indoor Air Quality” (including addendum 62a-1990).

1.03 DELIVERY, STORAGE, AND HANDLING:

Unit shall be stored and handled per manufacturer’s recommendation.

Part 2 — Products

2.01 EQUIPMENT:

- A. Each zone controller shall include a microprocessor based controller and shall be an integral part of the equipment. The zone controller shall control each function of its associated terminal. All application software shall be resident in the zone controller’s memory and shall be factory pre-tested and pre-configured.
- B. The zone controller shall provide stand-alone operation but shall include the inherent capability to being added on a network without the addition of any hardware. Systems that require an intermediate controller shall not be acceptable.

- C. The zone controller shall not require a battery. All configuration data shall be stored indefinitely in non-volatile memory. Systems that require a battery to store data are not acceptable.
- D. The zone controller shall be designed to be easily mounted in a standard NEMA type enclosure, attached to the unit without special rails or mounting hardware and as local and national electrical code dictates.
- E. All electrical components and control transformers shall be field mounted and wired inside the control box, as applicable.
- F. Each zone controller shall include the ability to maintain a 365-day clock with holiday functions and shall also support network broadcasts of time for clock synchronization. Each zone controller shall provide the capability to provide occupancy scheduling from its own local time schedule, or a time schedule within another controller on the network. Timed override requests through the space temperature sensor override button shall be performed by each zone controller without any network requirement. The zone controller shall be capable of interfacing to a portable PC for configuring, or altering the configuration, setting address, uploads, downloads, etc.

2.02 LINKAGE SYSTEM CAPABILITY:

- A. All terminals that are serviced by a common air handler shall be “LINKED” together to form a single virtual load and operate in unison as a complete system.
- B. One zone controller shall be designated as a linkage master between the Air Handler Controller and its associated terminals. The networked zone controller(s), through the linkage master, shall interface with a controller installed on the primary air source.
- C. The primary air system interface shall be a factory supplied microprocessor based controller that allows total closed loop system control.
- D. The Building Control System communications network and factory provided software shall allow dynamic interaction (linkage) of the air terminals with the primary air source to create a complete Air Distribution System (ADS) as later described within this specification. The bus that serves the zone controller(s) and air source shall include the ability to run at 38.4K bps, as a minimum.
Systems that do not include inherent linkage software shall state such in their bid/proposal.

2.03 ALARM/ALERT PROCESSING:

- A. The zone controller shall contain routine(s) to process alarms and alerts. Alarm/alert processing shall consist of a scan of all applicable point types and operating conditions.
- B. Certain analog alarms/alerts shall only be monitored when the zone controller is in the occupied mode (i.e., relative humidity, indoor air quality sensor, etc.).

- C. Time delays shall be provided with the software to prevent nuisance alarms/alerts during a transition period or if a set point change occurs.
- D. All alarms/alerts shall be displayed at a portable PC and via the network to a remote EMS operator's station or alarm printer as applicable.
- E. The ADS system shall contain a routine to process alarms. Alarm processing shall consist of a scan of all input points.
- F. The zone controller shall be shipped with factory entered default alarm thresholds. Alarm processing logic shall also monitor return to normal conditions as part of the alarm scan routine.

2.04 TERMINAL CONTROL TYPES:

- A. Terminal controls shall be field mounted and wired for the following types of VAV Pressure Independent terminals, as applicable:
 - 1. VAV Single Duct Terminals
 - a. Cooling only
 - b. Cooling with up to three stages of electric reheat
 - c. Cooling with two position hot water reheat
 - d. Cooling with modulated hot water reheat
 - e. Cooling only with perimeter heat; two position hot water, electric baseboard or modulating baseboard hot water
 - 2. VAV Parallel Fan Powered Terminals
 - a. Cooling with intermittent fan, induced air heat
 - b. Cooling with intermittent fan, induced air, and up to three stages of electric heat
 - c. Cooling with intermittent fan, induced air, and two-position hot water heat
 - d. Cooling with intermittent fan, induced air, and modulated hot water heat
 - 3. VAV Series Fan Powered Terminals
 - a. Cooling with constant fan, induced air heat
 - b. Cooling with constant fan, induced air, and up to three stages of electric heat
 - c. Cooling with constant fan, induced air, and two-position hot water heat
 - d. Cooling with constant fan, induced air, and modulated hot water heat
- B. Controls shall be field mounted and wired for those systems that require Constant Volume Dual Duct controls. The factory supplied controls shall be field configured for those applications that require space pressure control (DCFM) through two separate, single duct terminals.

2.05 ZONE CONTROLLER COMPONENTS:

As a minimum, the zone controller shall be supplied with the following standard control hardware for each terminal, as applicable:

- A. Airflow Pick-Up and Transducer:

Each zone controller shall include a field supplied, mounted and piped multi-point airflow pick-up. The pick-up shall provide a field piped differential pressure signal to an on-board airflow transducer

assembly. The airflow transducer shall automatically zero calibrate itself and shall be designed to read a flow signal of 0.0 to 2.0 in. wg.

- B. Leaving Air Temperature Sensor:

The leaving air temperature sensor shall be field provided and wired on all zone controllers that include heat. The leaving air terminal sensor shall consist of a thermistor in a stainless steel probe, with a nominal resistance of 10,000 ohms at 77 F (RTDs [Resistance Temperature Detectors] shall also be acceptable).
- C. Space Temperature Sensor:

The space temperature sensor shall be field supplied for field installation. The sensor shall consist of the following:

 - 1. A thermistor with a nominal resistance of 10,000 ohms at 77 F (RTDs shall also be acceptable)
 - 2. Termination block with screw terminals mounted on a printed circuit board
 - 3. Push button for remote occupant override
 - 4. A remote communication port (RJ11), if required.
 - 5. Sensors shall be capable of including a slide switch that may be used by the occupant to adjust the heating and cooling set points.
- D. Indoor Air Quality (IAQ) Sensor:
 - 1. Space CO₂ sensors shall be field supplied and wired to the zone controller to provide a Demand Controlled Ventilation control scheme.
 - 2. The sensor shall utilize a default of 0 to 2000 PPM range (system shall be capable of supporting a 0 to 5000 PPM range), as applicable.
 - 3. The sensor shall include an infrared diffusion sampling cell to eliminate pumps and dust filters.
 - 4. The sensor shall be capable of producing a proportional 0 to 10 vdc control signal.
 - 5. System supports optional IAQ or RH (relative humidity) analog input, but not both.
- E. Space Relative Humidity Sensor:
 - 1. The optional space relative humidity sensors shall be field supplied and wired to the zone controller.
 - 2. The zone controller shall supply all required power.
 - 3. The sensor shall use bulk polymer resistance technology.
 - 4. The minimum sensor accuracy shall be $\pm 3\%$ over a 10 to 90% RH.
- F. Zone Controller Damper Actuator:
 - 1. The zone controller shall include a direct coupled actuator used to control the primary air damper of the air terminal. The actuator shall provide torque limiting to permit the motor to stall at any position without incurring any damage. The actuator shall be field mounted to the damper and factory mounted and wired to the zone controller.

2. The actuator shall be fully compatible with the electronic control signal for the zone controller microprocessor.
3. The actuator shall be capable of providing a minimum of 35 in.-lb pounds of torque.
4. To ensure suitable pressure independent operation, the actuator shall be capable of going from full open to full closed (or vice versa) in 90 seconds, nominal.
5. Damper actuators shall contain a potentiometer that shall provide an indication of the damper position for the zone controller. The potentiometer shall provide a linear range of resistance reading over the entire range of the actuator. The zone controller shall include an input channel that shall convert this resistance reading to a percent open value (0 to 100%). The calculation shall be based on actual damper position and damper range. It shall be reversible via software for counterclockwise or clockwise opening dampers. This shall allow the damper action to be switched (Normally Open or Normally Closed) without removing or re-wiring the actuator. Systems that monitor actuator stroke time or position shall not be acceptable.
6. The damper feedback shall also be used by the system static pressure reset algorithm and for air flow sensor zero calibration.

G. Zone Controller Enclosure:

The zone controller, if required by code or mentioned elsewhere in the specification, shall be housed within a field supplied and installed enclosure and shall allow for field wiring connections through the use of screw terminals.

2.06 ZONE CONTROLLER POWER REQUIREMENTS:

The power requirements for each zone controller shall be field wired and supplied for all terminals. These transformers shall be field mounted and wired by this contractor unless otherwise specified.

2.07 VALVE ASSEMBLIES:

- A. Valve assemblies shall be made up of a valve body, linkage, and actuator. Actuators shall be fully compatible with the terminal unit control signal. Actuators shall be two position or modulating type. The valve assemblies shall be sized to provide the required GPM at the pressure drops specified within this specification. All valve assemblies shall be field installed per the valve suppliers instructions by the mechanical contractor. The energy management contractor shall provide all necessary wiring and terminations for proper operation unless otherwise mentioned.
- B. All wire required for all the items above shall meet all applicable codes and shall be plenum rated.

Part 3 — ADS Requirements

3.01 AIR DISTRIBUTION SYSTEM:

- A. Multiple zone controllers being serviced by the same air handler shall be networked together.
- B. Each zone controller shall include an occupancy schedule or may share a global occupancy control for an entire designated group.

- C. Each zone controller shall be capable of supporting holiday periods.
- D. Each zone controller shall include the capability to monitor one space temperature sensor and CO₂ sensor or Relative Humidity sensor.
- E. The zone controller shall monitor primary airflow, space temperature, air handler status and mode, supply-air temperature (as applicable) and shall position its terminal damper based on its PID temperature control algorithm to maintain the desired zone temperature set point.
- F. Each zone controller shall include the inherent ability to override the temperature control loop and modulate the terminal's damper with a PI loop, based on a ventilation sensor or a Relative Humidity sensor with its associated set point schedule, in conjunction with the normal temperature control loop.
- G. The zone controller shall be capable of maintaining an air quality set point through a Demand Controlled Ventilation algorithm in conjunction with the Air Handler to fulfill the requirements of ASHRAE standard, 62-1989 "Ventilation For Acceptable Indoor Air Quality" (including addendum 62a-1990). The algorithm shall also be capable of modulating the heat to keep the space temperature between the heating and cooling set points. The IAQ algorithm shall be temporarily suspended if the space temperature falls below the heating set point. The system shall also include the capability for a maximum primary airflow limit to protect the zone from over cooling for those units that do not include local heating.
- H. For Relative Humidity applications, the zone controller shall also be capable of overriding the amount of primary air up to an operator adjustable higher CFM value, whenever the space Relative Humidity exceeds its set point during the Occupied mode. Systems that allow simultaneous heating and cooling shall not be acceptable.
- I. Depending upon the type of terminal, the zone controller shall sequence the terminal's fan, hot water valve or auxiliary heat as required.
- J. Depending on the equipment mode of operation, separate heat/cool, minimum/maximum, airflow set points shall be used to help protect the equipment from insufficient airflow during heating (minimum heating CFM) or overload (maximum heating and maximum cooling CFM).
- K. Auxiliary heating for IAQ applications shall be of the modulating hydronic type. Two-position actuator shall not be acceptable for IAQ applications.
- L. All parallel fan powered terminals with local auxiliary heat shall include a heat on delay timer (unless in the commissioning mode) to ensure that the use of plenum air is insufficient before any heat stage is enabled. All ducted heat shall be controlled so as not to exceed a user defined maximum duct temperature. All fan powered terminals with local auxiliary heat shall also include a fan off delay value, to ensure that the heat has been sufficiently dispersed before disabling the fan. All timers shall be provided in software.

- M. Each space temperature sensor shall include an override button as an integral part of the sensor. Whenever the button is pushed during the unoccupied mode, the zone shall be indexed to control to its occupied set points, the air source shall start, and the zone shall stay in its Occupied mode for the duration of the override period. The timed override duration shall be operator configurable from one minute to 24 hours in one-minute increments.
- N. For Constant Volume, Dual Duct applications, two dampers with two separate actuators and two separate airflow pressure sensors shall be used to provide airflow control. The algorithm shall modulate the primary air damper located in the cold deck in order to maintain the space temperature between the desired set points. The control based on a second airflow sensor located in the second inlet shall calculate the required air flow necessary through the second inlet based on its CFM calculations to maintain a total airflow balance. As the cold deck is modulated, the hot deck shall also modulate to maintain this adjustable balance point. For those applications where the second probe is located in the terminal outlet, the control shall monitor the resulting total airflow as the cold deck is modulated. The control shall then modulate the hot deck, as required, to achieve the Dual Duct constant volume airflow set point.

3.02 SYSTEM TERMINAL MODES:

- A. Each air terminal mode shall be based on the current air handler mode, terminal type, space temperature, and the current temperature set points.
- B. All zone controller's servicing Series fan terminals shall include a Series Fan Terminal Precheck (SFTP) algorithm before starting its fan and control sequence. The SFTP algorithm shall ensure proper fan rotation whenever the fan is commanded on, by closing its damper, waiting for a short time delay, and then enabling its fan. Actual damper position shall be required for this algorithm. After the fan starts the zone controller shall modulate its damper. Each zone controller servicing Series terminals shall include a unique time delay to prevent all dampers from closing at once, and to prevent all the fans from starting at the same time.
- C. If at any time the air source is providing cooling, and a parallel fan terminal's primary air CFM value falls below a user adjustable minimum CFM set point, the zone controller shall enable its fan. If the CFM exceeds this set point, then the fan shall be disabled. The terminal operation depends upon the air source operation and zone requirements as follows:
 - 1. OFF:
 - a. If the zone requirement is none or cooling, and the air source is not operating, all terminal dampers shall hold their last position

until auto calibration is performed. The terminal dampers shall then modulate their dampers to maintain a 50% open position. Both Parallel and Series fans shall be disabled.

- b. If the zone requirement is heating, all single duct, dual duct, and series fan terminals shall hold their last damper position. Any zone controller servicing a parallel box shall fully close their dampers while the fan is operating. If local heat is available, the series and parallel fans shall start and local heat shall be enabled to maintain its unoccupied heating set point. For Parallel fans, the air damper shall close to prevent backflow through the supply air duct, if required to operate for unoccupied heating. The damper shall be modulated open to 50% after heating is no longer required.
2. WARM-UP:
- a. Warm-up shall only occur once per day so all zones associated with an air handler in a Warm-Up mode shall participate in the warm-up cycle regardless of their occupancy schedule. If the zone has no requirement for heat, the zone controller shall modulate its primary air damper to its configured minimum heating CFM set point. Parallel fans shall be disabled. Any zone controller servicing a Series fan terminal shall modulate their dampers after completing the SFTP cycle.
 - b. If the zone is calling for cooling, the zone controller shall modulate its damper to maintain its minimum heating CFM set point. Parallel fans shall be disabled. Any zone controllers servicing Series fan terminals shall also maintain their minimum heating CFM set point after completing its SFTP cycle.
 - c. If the zone is calling for heating and is configured to use central heat, the zone controller shall modulate its terminal damper between its minimum and maximum heating CFM set points to maintain its occupied heating set point. Series terminal zone controllers shall also modulate their air damper between their minimum and maximum CFM set points after completing the SFTP cycle. If the zone controller is not configured for central heat, the zone controller shall modulate its damper to maintain its minimum CFM heating set point. Parallel fan zone controllers and their associated heating control shall be capable of being enabled if the zone controller is not configured for central heat.

3. Cooling, Fan Only, and Night Time Free Cooling (NTFC):

- a. If the zone requirement is none, then the zone controllers shall modulate their dampers to maintain their minimum cooling CFM set point. Any zone controllers servicing Series terminals shall also modulate their dampers to maintain their minimum cooling CFM set point after completing their SFTP cycle. During the NTFC mode the zone controller shall control between its heating and cooling set points. During the other modes the zone controller shall modulate its damper to its occupied cooling set point. Parallel fans shall only be enabled if the required CFM falls below an operator adjustable CFM limit.
- b. If the zone requirement is cooling, then the zone controllers shall modulate their air dampers between their minimum and maximum cooling CFM set points to maintain their cooling set point. Parallel fans shall be disabled. Series fans shall start and control after completing their SFTP cycle. For those terminals that include humidity control, the damper shall be modulate to an adjustable maximum if the unit is occupied and heating is not active. The local Relative Humidity control shall be disable if the space temperature falls below the heating set point.
- c. If the zone requirement is heating, then the zone controllers shall modulate their dampers to maintain their minimum cooling CFM set point. Any zone controllers servicing Series fans shall complete their SFTP cycle before modulating their dampers. Any zone controllers servicing single duct units with reheat capability shall maintain the greater of either the minimum reheat cooling CFM set point or the minimum reheat CFM set point. Zone controllers servicing parallel units shall enable their fans. Zone controllers servicing Series terminals shall complete their SFTP cycle before modulating their dampers. After the fan starts, the damper shall be modulated to maintain its minimum cooling CFM set point.

4. Heat:

- a. If the zone requirement is none, then the zone controller shall maintain its minimum heating CFM set point. Parallel fans shall be disabled and their air damper shall be modulated to maintain their minimum heating CFM set point. Series units shall complete their SFTP cycle checks and then modulate its damper to maintain its minimum heating CFM set point.
- b. If the zone requirement is cooling, then the zone controller shall modulate its damper to maintain its minimum heating CFM set point. Parallel fans shall be disabled. Zone controllers servicing Series units shall complete their SFTP cycle and then shall

modulate their primary damper to maintain their minimum heating CFM set point.

- c. If the zone requirement is heating, and the zone controller is configured to use central heat, then it shall modulate its damper between its minimum and maximum heating CFM set points to maintain its heating set point. If it is not configured for central heat, it shall maintain its minimum heating CFM set point. Zone controllers servicing parallel units shall enable their fan. Zone controllers servicing Series fans, after completing their SFTP cycle, shall modulate their damper between their minimum and maximum heating CFM set points (if configured for central heat). Otherwise, the zone controller shall modulate its air damper to maintain its minimum heating CFM set points.

5. Pressurization:

- a. If the zone requirement is none or cooling, then the zone controller shall maintain its maximum cooling CFM set point. Parallel fans shall be disabled. The damper for series fans, after successfully completing its SFTP cycle, shall modulate to maintain the maximum cooling CFM set point.
- b. If the zone requirement is heating, and the zone controller has been enabled to provide local heating, then the zone controller shall modulate its damper to its maximum cooling CFM set point and enable its auxiliary heat. If local heat is not available, the damper shall be modulated to maintain its maximum cooling CFM set point.
- c. For series fan operations, the SFTP cycle shall be completed before modulating the primary air damper to its maximum cooling CFM set point.

6. Evacuation:

During the Evacuation mode all terminal fans shall be disabled and all dampers shall close.

Part 4 — Abnormal Conditions

4.01 The proposed system shall include the ability to detect abnormal conditions, and to react to them automatically. A return to normal conditions shall also generate a return to normal notification and the system shall revert back to its original control scheme before the abnormal condition existed.

The following abnormal terminal conditions shall automatically generate an alarm and the system shall take the following actions:

- A. If a space temperature sensor is determined by the zone controller to be invalid, the zone controller shall generate an alarm, default to its Cooling mode and maintain its minimum cooling CFM set point.
- B. If a relative humidity sensor is determined by the zone controller to be invalid, the zone controller shall generate an alarm and disable its humidity algorithm.
- C. If an indoor air quality sensor is determined by the zone controller to be invalid, the zone controller

shall generate an alarm, and disable its IAQ algorithm.

- D. If a zone controller loses communication with its associated coordinator, it shall generate an alarm. If the zone controller does not have a supply-air sensor installed, then the zone controller shall assume it is in a Cooling mode and modulate its primary air damper between its minimum and maximum cooling CFM set points. If the zone includes a reheat coil, it shall also be controlled to maintain its heating set point.
- E. If a linkage master loses communications with the equipment controller and it has a primary air temperature sensor installed, the linkage master zone controller shall determine the equipment operating mode based on its damper position, airflow, and the temperature of the primary air.
- F. If a linkage master loses communication with an associated zone controller, the linkage master shall alarm and remove that zone temperature from its weighted averages. The zone controller shall continue to operate in a stand-alone mode.

Part 5 — System

5.01 The system shall include the ability to configure and display up to 128 zones for each air source. A zone shall be defined as a space temperature sensor wired to a zone controller.

A. Configuration:

Each zone shall have the ability to configure and display the following:

1. Minimum/Maximum CFM limits used by the terminal control when the air source is in the Cooling mode.
2. Minimum/Maximum CFM limits used by the terminal control when the air source is in the Heating mode.
3. Reheat CFM limit (single duct units only) used when local heat is required and the air source is in Cooling mode.
4. Parallel fan CFM limit (parallel fan terminals only).
5. CFM Multiplier (for field calibration if required).
6. Inlet probe multiplier.
7. Terminal Inlet size (diameter or square inches).
8. Offset CFM adjustment.
9. Heating type.
10. Central Heating enabled/disabled.
11. Heat on delay.
12. Fan off delay (parallel terminal fans only).
13. Maximum duct temperature.
14. Alarm set points.
15. Occupancy Override value.
16. Heating and cooling Occupied/Unoccupied temperature set points.

17. Ventilation set point (CO₂) and airflow limit.
18. Heat enable/disable.
19. High Relative humidity set point and airflow limit.

B. Zone Display:

Zones shall have the capability to display the following as a minimum:

1. Terminal operating mode and terminal type.
2. Zone space temperature.
3. Actual damper blade position (0 to 100% open).
4. Primary airflow in CFM .
5. Primary air temperature (if applicable).
6. Terminal fan status (if applicable).
7. Heating capacity (0 to 100%, if applicable).
8. Leaving temperature (heating only).
9. Zone CO₂ (if applicable).
10. Zone Relative Humidity (if applicable).
11. Secondary airflow (if applicable).

C. Maintenance Display:

Maintenance screens shall be provided to ease and expedite the task of troubleshooting. The screens shall have the capability to display the following as a minimum:

1. The current calculated CFM set point.
2. Occupancy and override status.
3. Current user set point offset value.
4. Current heating and cooling set points.
5. Heat Status (if applicable).
6. Ducted heating reference temperature.
7. Heating/cooling BTUs supplied.
8. The current calculated secondary CFM set point (zone pressure control applications only).
9. Current Air Source operating mode and supply temperature.
10. Average zone temperature, average occupied zone temperature, and the next occupied/unoccupied day and time for all terminals serviced by each respective air handler (linkage master only).
11. Occupancy maintenance screens shall display such information as timed override status and duration and current occupied and unoccupied time (Local schedule only).
12. Position of the greatest open primary air damper of all terminals serviced by their respective air handler (coordinator only).
13. Current calculated static pressure reset value (coordinator only).

Part 6 — Linkage

6.01 Each zone controller shall have the capability to directly communicate to a factory supplied air source microprocessor to provide a totally linked and coordinated Air Distribution System.

- A. The linkage shall include the following air source modes for use by the Coordinator as a minimum: Off, Cooling, Heating, Morning Warm-Up, Night Time Free Cooling, Pressurization, and Evacuation.
- B. The linkage shall also provide system data to the air source controller for use in its algorithms.
- C. The coordinator shall periodically poll its assigned zones to acquire their updated values.
- D. Space temperature and space temperature set points acquired by the coordinator for use by the air handler controller shall include a weighted factor, proportional to the size of the zone.
- E. Only those zones with valid temperature readings shall be included.
- F. The system data shall include average zone temperature, average occupied zone temperature, average occupied and unoccupied heat/cool set points, occupancy status, and the next occupied zones terminal time and day.
- G. A static pressure reset value shall be supplied for optimization purposes as applicable.
- H. Maximum CO₂ or space relative humidity shall be supplied to the air source through other networking means.
- I. The system shall provide the capability of using the above data in the air source algorithms for adaptive optimal start, Night Time Free Cooling, morning warm-up, supply temperature reset, dehumidification, static pressure control, and Demand Controlled Ventilation adjustments to the mixed air damper routine.
- J. The air handler controller shall, through the Air Distribution System, bias its occupancy time schedules to provide optimization routines and occupant override.
- K. For those systems that do not include inherent linkage software, the Coordinator shall determine the operational mode of the equipment through its own flow sensor and a temperature sensor mounted in the supply ductwork.
- L. The vendor shall make it clear in the bid/proposal if linkage software is not going to be part of their offering.

Manufacturer reserves the right to discontinue, or change at any time, specifications or designs without notice and without incurring obligations.