

Installation Instruction

NOTE: Read the entire instruction manual before starting the installation.

SAFETY CONSIDERATIONS

Improper installation, adjustment, alteration, service, maintenance, or use can cause explosion, fire, electrical shock, or other conditions which may cause death, personal injury, or property damage. Consult a qualified installer, service agency, or your distributor or branch for information or assistance. The qualified installer or agency must use factory-authorized kits or accessories when modifying this product. Refer to the individual instructions packaged with the kits or accessories when installing.

Follow all safety codes. Wear safety glasses, protective clothing, and work gloves. Use quenching cloth for brazing operations. Have fire extinguisher available. Read these instructions thoroughly and follow all warnings or cautions included in literature and attached to the unit. Consult local building codes and current editions of the National Electrical Code (NEC) NFPA 70. In Canada, refer to current editions of the Canadian electrical code CSA 22.1.

Recognize safety information. This is the safety-alert symbol . When you see this symbol on the unit and in instructions or manuals, be alert to the potential for personal injury. Understand these signal words; DANGER, WARNING, and CAUTION. These words are used with the safety-alert symbol. DANGER identifies the most serious hazards which **will** result in severe personal injury or death. WARNING signifies hazards which **could** result in personal injury or death. CAUTION is used to identify unsafe practices which **would** result in minor personal injury or product and property damage. NOTE is used to highlight suggestions which **will** result in enhanced installation, reliability, or operation.



WARNING

ELECTRICAL SHOCK HAZARD

Failure to follow this warning could result in personal injury or death.

Before installing, modifying, or servicing system, main electrical disconnect switch must be in the OFF position. There may be more than 1 disconnect switch. Lock out and tag switch with a suitable warning label.



CAUTION

CUT HAZARD

Failure to follow this caution may result in personal injury.

Sheet metal parts may have sharp edges or burrs. Use care and wear appropriate protective clothing and gloves when handling parts.

Use only the kit components described in this installation procedure.

INTRODUCTION

These instructions cover installation of Low-Pressure Switch Kit KAALP0301R22 on split system air conditioners containing R-22 refrigerant and KAALP0401PUR on air conditioners containing Puron® (R-410A) refrigerant.

Kit contents:

- Low-Pressure Switch – 1
- Adapter Tee – 1
- Flare Gasket – 2
- Pressure Switch Adapter Tube – 1
- Installation Instructions – 1

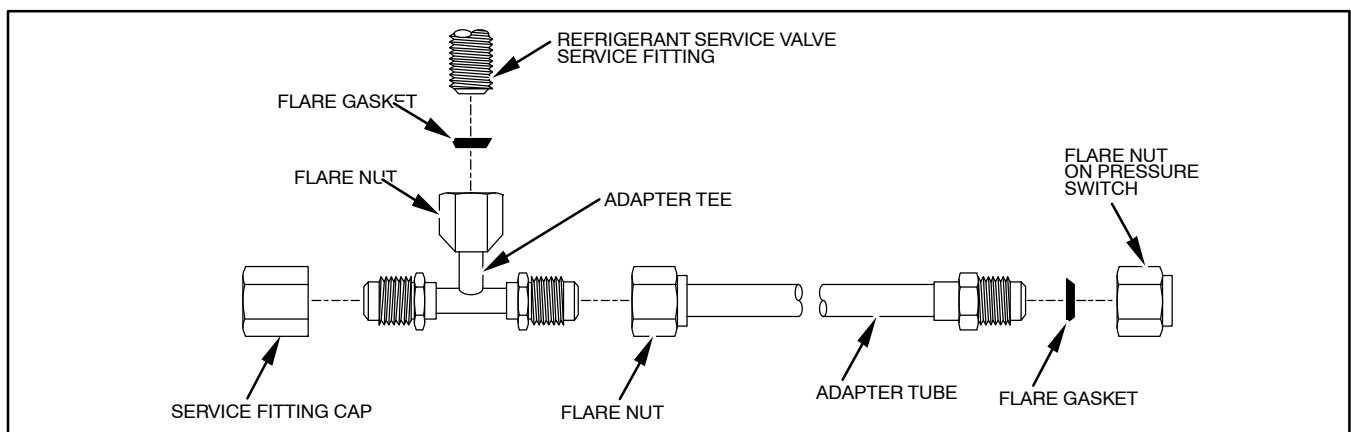

Fig. 1 – Low-Pressure Switch Refrigerant Connections

INSTALLATION

⚠ CAUTION

EQUIPMENT DAMAGE AND/OR OPERATION HAZARD

Failure to follow this caution may result in equipment damage or improper operation.

When making flare connections, use one of the flare gaskets provided in the kit to ensure a leak-tight refrigerant connection. Use a backup wrench to avoid breaking connection or splitting flare.

NOTE: The liquid- and vapor-service valves are located outside of the unit at the rear. The smaller valve is the liquid-service valve; the larger valve is the vapor-service valve.

Switch Refrigerant Connections:

NOTE: Make sure the liquid-service valve is in the fully back seated (counterclockwise) position before installation (Back seating service valves have no valve core in the service port).

Refer to Fig. 1 and proceed as follows to install the low-pressure switch.

1. For vertical discharge units, remove knockout in service panel next to service valves. For horizontal discharge units, either drill a hole in the service valve plate or route switch through existing service valve holes.
2. Remove valve core from one end of adapter tee provided in kit.
3. Securely connect pressure switch adapter tube flare nut to side of adapter tee without valve core.
4. Route the adapter tube completely through the knockout (vertical discharge units) or service valve hole (horizontal discharge units) so that tee can be attached to vapor service valve later.
5. Securely connect pressure switch flare nut, using flare gasket, to male flare fitting on the pressure switch adapter tube inside the unit.
6. Remove seal cap from service fitting on vapor-service valve on unit and securely connect to remaining male flare fitting on adapter tee.
7. Securely connect flare nut on adapter tee, using flare gasket to service fitting on service valve.
8. On back seating valves, remove service valve stem cap and open valve 3/4 turn.
9. Replace service valve stem cap fingertight and further tighten cap 1/6 turn, or 1/12 turn on back seating valves.
10. Check all refrigerant connections for leaks and repair if necessary.

ELECTRICAL CONNECTIONS

Refer to Fig. 2 and proceed as follows:

1. Locate unit contactor coil terminals or, if equipped, compressor time delay terminal T1.
2. On units without compressor time delay, make electrical connections as follows:
 - a. One pressure switch in unit: Disconnect Y lead from contactor coil terminal. Connect 1 pressure switch lead to Y lead. Connect other pressure switch lead to contactor coil terminal.
 - b. Both high- and low-pressure switches in unit: Disconnect Y lead from contactor coil terminal. Connect 1 high pressure switch lead to Y lead, then connect other high-pressure lead to 1 low-pressure lead. Connect remaining low-pressure lead to contactor coil terminal.
3. On units with compressor time delay, make electrical connections as follows:
 - a. One pressure switch in unit: Disconnect wire leading to T1 on time delay board. Connect 1 pressure switch lead to disconnected lead. Connect other pressure switch lead to T1 on time delay board.
 - b. Both high- and low-pressure switches in unit: Disconnect wire leading to T1 on time delay board. Connect 1 high-pressure lead to disconnected lead, then connect other high-pressure lead to 1 low-pressure lead. Connect remaining low-pressure lead to T1 on time delay board.
4. Restore power and check unit operation.

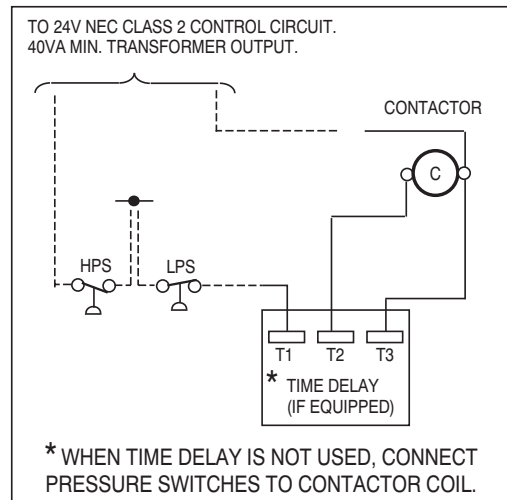

Fig. 2 – Air Conditioner Electrical Connections

A07630