

Installation Instructions

NOTE: Read the entire instruction manual before starting the installation. Use only the kit components described in this installation procedure.

SAFETY CONSIDERATIONS

Installing and servicing air conditioning equipment can be hazardous due to system pressures and electrical components. Only trained personnel should install or service air conditioning equipment.

Untrained personnel can perform basic maintenance functions such as cleaning coils, or cleaning and replacing filters. All other operations should be performed by trained service personnel. When working on air conditioning equipment, observe precautions in the literature, on tags, and on labels attached to the unit.

Follow all safety codes. Wear safety glasses, protective clothing, and work gloves. Use quenching cloth for brazing operations. Have fire extinguisher available. Read these instructions thoroughly and follow all warnings or cautions included in literature and attached to the unit. Consult local building codes and current editions of the National Electrical Code (NEC) NFPA 70. In Canada, refer to current editions of the Canadian electrical code CSA 22.1.

Recognize safety information. This is the safety-alert symbol . When you see this symbol on the unit and in instructions or manuals, be alert to the potential for personal injury.

Understand these signal words; DANGER, WARNING, and CAUTION. These words are used with the safety-alert symbol. DANGER identifies the most serious hazards which **will** result in severe personal injury or death. WARNING signifies hazards which **could** result in personal injury or death. CAUTION is used to identify unsafe practices which **may** result in minor personal injury or product and property damage. NOTE is used to highlight suggestions which **will** result in enhanced installation, reliability, or operation.

WARNING

ELECTRICAL OPERATION HAZARD

Failure to follow this warning could result in personal injury or death.

Before beginning any installation or modification, be sure the main electrical disconnect switch is in the OFF position. TAG THE DISCONNECT SWITCH WITH A SUITABLE WARNING LABEL.

CAUTION

CUT HAZARD

Failure to follow this caution may result in personal injury.

Sheet metal parts may have sharp edges or burrs. Use care and wear appropriate protective clothing and gloves when handling parts.

INTRODUCTION

This instruction covers the installation of liquid-line solenoid valve kit Part No. KAALS0101LLS (single-flow) for air conditioner applications using R-22 refrigerant only and KAALS0201LLS (single-flow) for air conditioner applications using Puron (R-410A) refrigerant only and Part No. KHALS0401LLS (bi-flow) for heat pump only applications using R-22 or Puron (R-410A) refrigerant.

Table 1 – Liquid Line Solenoid Kit Usage

AIR CONDITIONER (single-flow)	HEAT PUMP (bi-flow)	APPROVED REFRIGERANT
*KAALS0101LLS	KHALS0401LLS	R-22
*KAALS0201LLS	KHALS0401LLS	Puron (R-410A)

*Used on single-speed units only.

NOTE: The installation of some units may require the use of a hard shut-off TXV on the indoor coil. Refer to the equipment Installation Instructions and the Residential Piping and Long Line Guideline or Service Manual, or consult your distributor.

DESCRIPTION AND USAGE

The liquid-line solenoid valve closes when the thermostat demand is satisfied to prevent liquid refrigerant migration. This device is for use in long-line applications.

NOTE: Refer to condensing unit or heat pump Installation Instructions for detailed control wiring.

NOTE: For single-speed units, an accessory start capacitor and relay is required when using the liquid-line solenoid valve with single-phase single speed compressors.

INSTALLATION

NOTE: For use in long-line applications, refer to the Residential Piping and Long Line Guideline for locations and flow arrow direction.

⚠ CAUTION

COMPONENT DAMAGE HAZARD

Failure to follow this caution may result in component failure due to excessive loading.

A field-supplied 60va control power source may be necessary when adding the solenoid valve. Determine transformer loading prior to installation. Wiring must comply with local and National Electrical Code (NEC) requirements.

Air Conditioning Application or Heat Pump Cooling Enhancement

1. Remove clip holding solenoid coil on valve assembly and slide coil off valve stem.
2. Wrap solenoid valve body with wet cloth to prevent distortion from heat.
3. Remove and discard solenoid valve end caps. Braze solenoid valve in liquid line within 2 ft (.61 m) of indoor coil. Solenoid valve flow arrow must point toward indoor coil.
4. Reinstall solenoid coil and retainer clip. Solenoid valve must be mounted with coil above valve body. (See Fig. 1.)

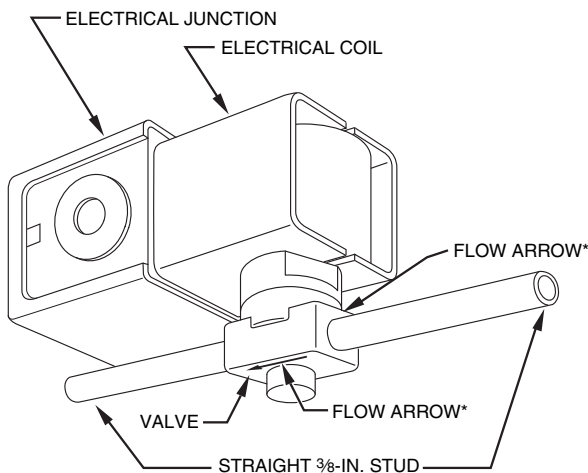

NOTE: System flow direction must match arrow on bottom of body.

- * KAALS0101LLS – Flow arrow on bottom of valve body
- KAALS0201LLS – Flow arrow on top of valve body

Fig. 1 - Air Conditioner Solenoid Valve

A04213

Heat Pump Application Heating Enhancement Or Heat Pump Long Line Application

1. Cut liquid line within 2 ft (.61 m) of outdoor unit (depending on application).
2. Place 3/8-in. flare nuts on cut ends of liquid line and flare both ends.
3. Remove and discard solenoid valve end caps, then connect flare nuts to solenoid valve assembly. Solenoid valve must be mounted with coil above valve body (see Fig. 2). Arrow on valve body must point toward outdoor unit.

NOTE: When solenoid valve is de-energized (closed), refrigerant flow will be stopped only in the direction of the flow arrow on the valve body.

Wiring

Solenoid coil must be wired into 24-v control circuit so coil is energized (open) with outdoor unit. For single-stage units, wire solenoid coil between Y (contactor) and C (common) terminals. (See Fig. 3.)

For single-stage units using Infinity or Evolution communicating controls, wire solenoid between LS and C terminals on outdoor unit control board (see Fig. 5).

For two-stage units using Infinity or Evolution controls (Model SYSTX), wire solenoid between Y and C on outdoor unit control board. The Y terminal is energized during compressor operation (see Fig. 6).

For all other two-stage units, two single-pole, single throw relays are required to be wired per Fig. 4. The liquid line solenoid valve must be wired between relay contacts and C (common) terminals. (See Fig. 4.)

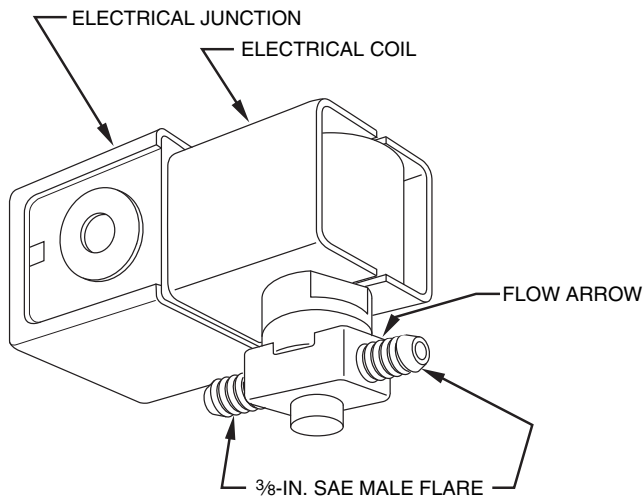

Fig. 2 - Heat Pump Solenoid Valve

A04214

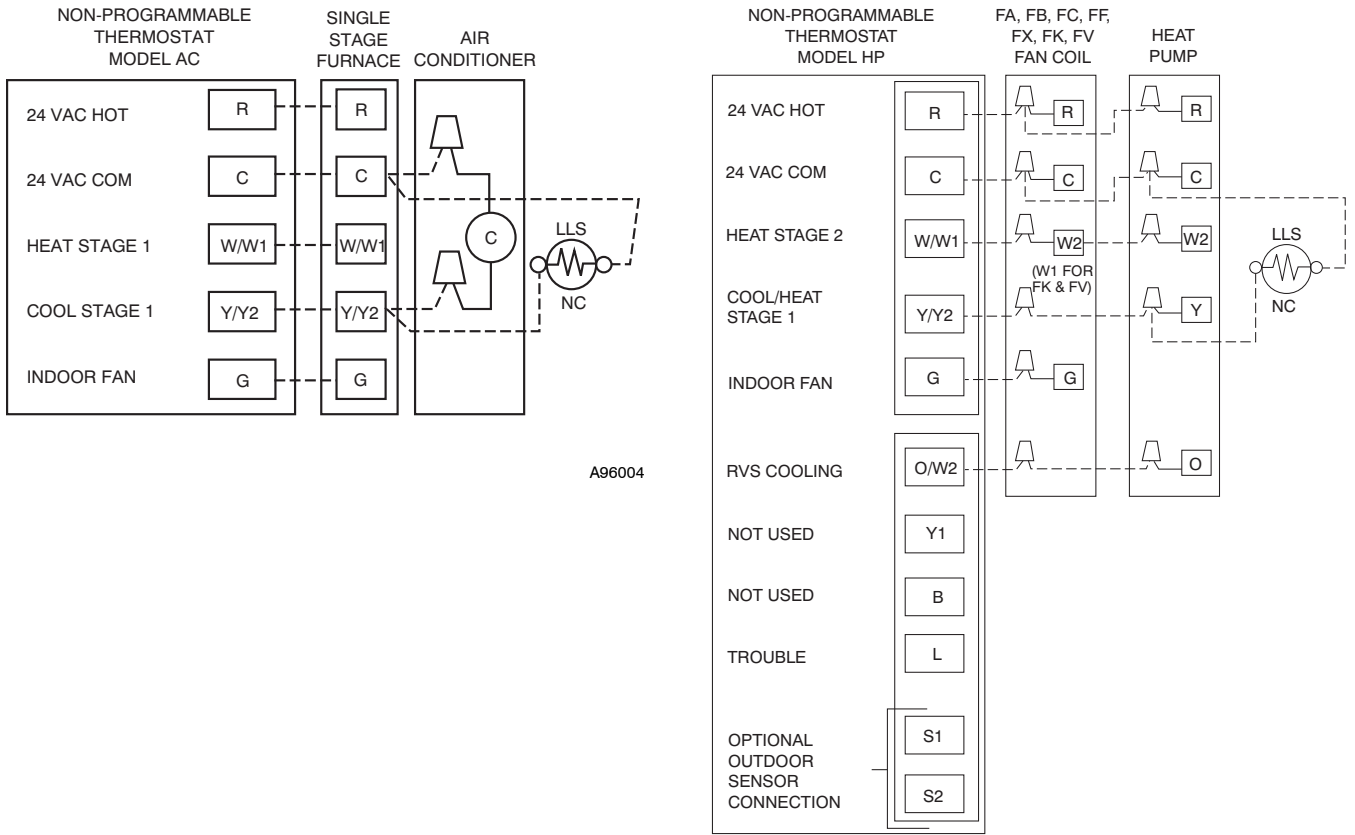

Fig. 3 - Typical Solenoid Valve Wiring (Single-Stage units) with Non-Communicating Thermostat

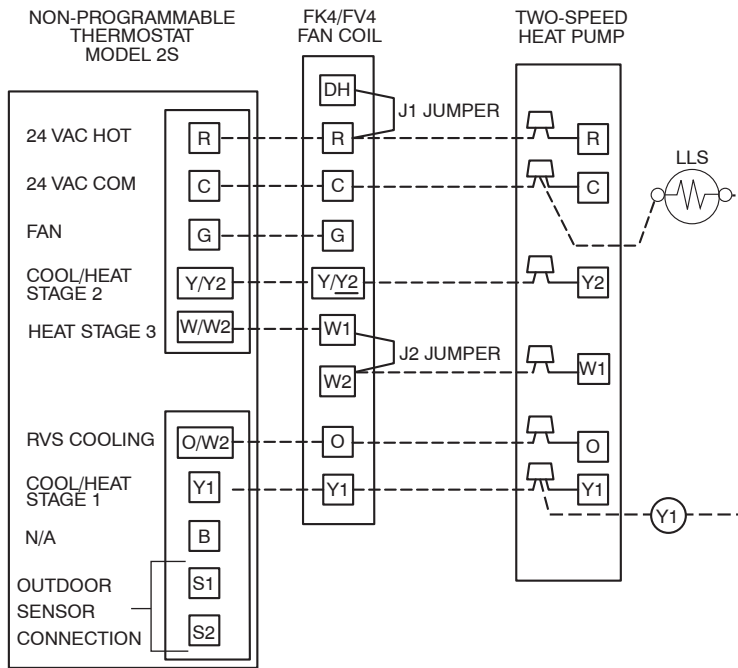
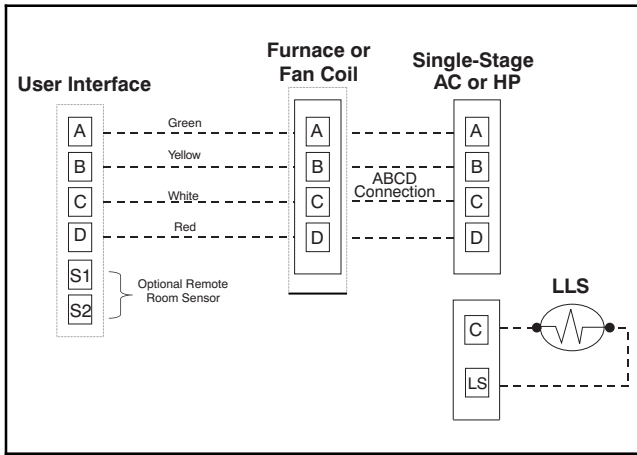
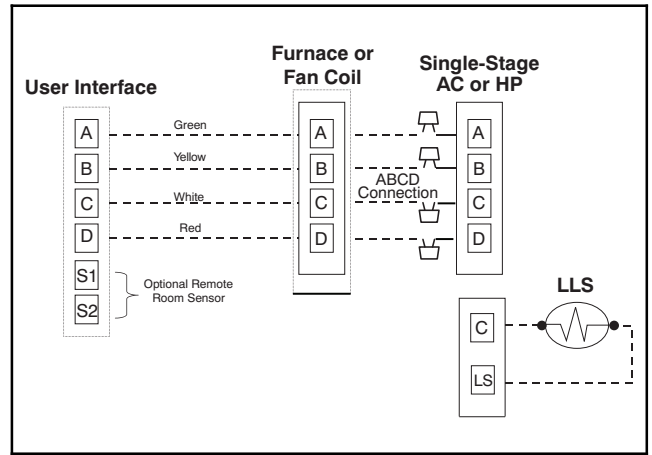

Fig. 4 - Typical Solenoid Valve Wiring (2-Stage Units)

A10102



A10103



A10104

Fig. 5 - Connection Diagram for Infinity or Evolution Communicating System (Single-Stage units)

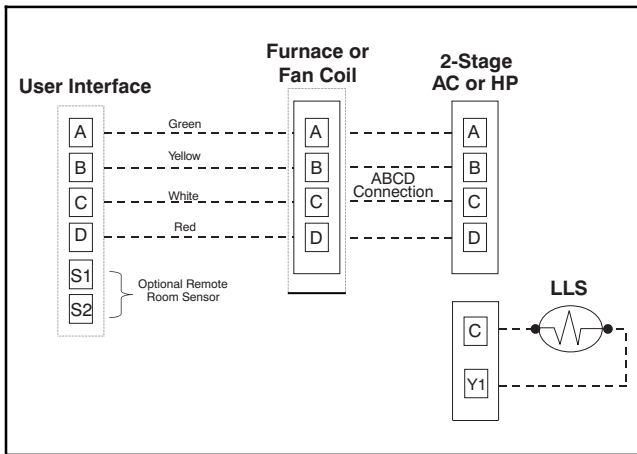

A10100

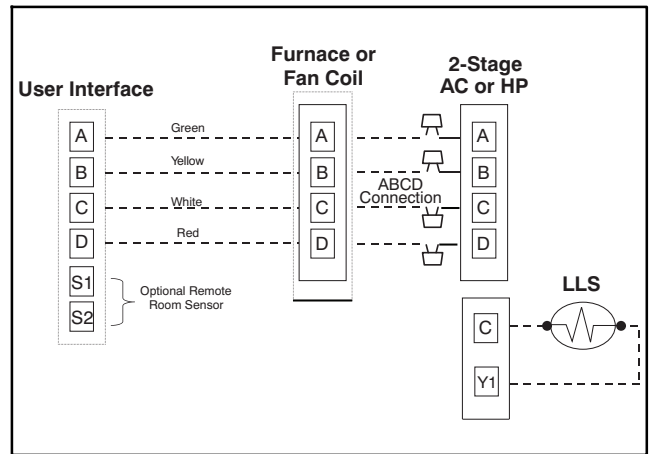

A10101

Fig. 6 - Connection Diagram for Infinity or Evolution communicating System (2-Stage units)