

Packaged Air-Handling Units 6 to 30 Tons Condensate Drain Trap Accessory 50/60 Hz

Cancels: New

IIK 524A-72-7
10/15/95

Installation Instructions

Part No. CAOVRFLW001A00

SAFETY CONSIDERATIONS

Installation of this accessory can be hazardous due to electrical components and equipment location (such as a ceiling or elevated structure). Only trained, qualified installers and service mechanics should install and service this equipment.

When installing this accessory, observe precautions in the literature, labels attached to the equipment, and any other safety precautions that apply.

- Follow all safety codes.
- Wear safety glasses and work gloves
- Use care in handling and installing this accessory.



ELECTRIC SHOCK HAZARD

To avoid the possibility of electrical shock, open and tag all disconnects before installing this equipment.

INTRODUCTION

The condensate drain trap accessory kit (Fig. 1) includes a compact, adjustable drain pan trap for 6 to 30 ton packaged air handling units. The trap can be used in vertical (up-flow) or horizontal installations, and is easier to install and service than a conventional trap. The trap includes an overflow shutoff switch that can be wired to turn off the unit or system if the drain trap becomes plugged. The included wire harness has a lead that can be connected to an alarm if desired.

The condensate drain trap accessory also makes trap maintenance easier. The bottom of the trap is transparent to show obstructions and a flexible cleaning brush is provided for routine maintenance.

INSTALLATION

Complete Pre-Installation Checks — Remove accessory packaging and inspect shipment for damage. See Table 1 for kit contents. File claim with shipping company if accessory is damaged or incomplete.

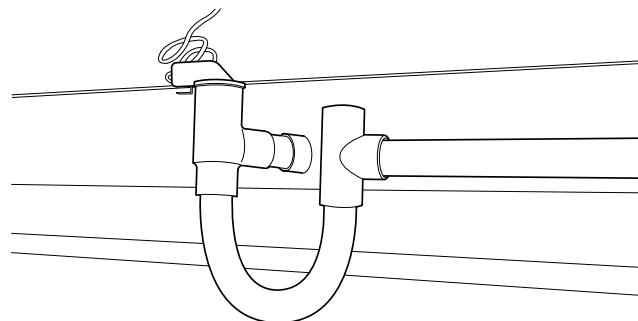

Fig. 1 — Condensate Drain Trap Accessory

Table 1 — Accessory Kit Contents

Quantity	Description
1	Transparent Trap Tube
1	Overflow Switch Assembly
1	1-in. PVC Nipple
1	24-v Relay
1	Wire Harness
1	1-in. x 1-in. x 3/4-in. PVC Tee
1	3/4-in. x 3/4-in. x 3/4-in. PVC Tee
1	Pipe Cap
1	Cleaning Brush

Install Trap

NOTE: Use PVC pipe primer and cement to make all connections.

1. Cement 1-in. PVC pipe nipple (supplied) into the drain pan pipe stub. See Fig. 2.

NOTE: Units manufactured before January 1, 1996, require a field-supplied 1 1/4-in. x 1-in. female PVC coupling between pipe nipple and drain pan pipe stub.

2. Cement the 1-in. x 1-in. x 3/4-in. PVC tee with the stepped body onto the other end of the nipple so that the main body of the tee is vertical and the 1-in. end of the straight-thru section is up.

3. Cement the longer leg end of the transparent trap into $\frac{3}{4}$ -in. connection in bottom of tee; swivel trap towards direction where condensate drain line is to be installed. See Fig. 3.
4. Cement the $\frac{3}{4}$ -in. x $\frac{3}{4}$ -in. x $\frac{3}{4}$ -in. PVC tee onto other end of trap, with the main body of the tee vertical.
5. Cement $\frac{3}{4}$ -in. PVC condensate drain pipe in horizontal section of second tee. Slope pipe away from unit for proper drainage. Pipe must have separate supports; do not support pipe from trap.
6. Install pipe cap in top of $\frac{3}{4}$ -in. x $\frac{3}{4}$ -in. x $\frac{3}{4}$ -in. tee.
7. Install overflow switch assembly in top of tee closest to unit. See Fig. 3 and 4.

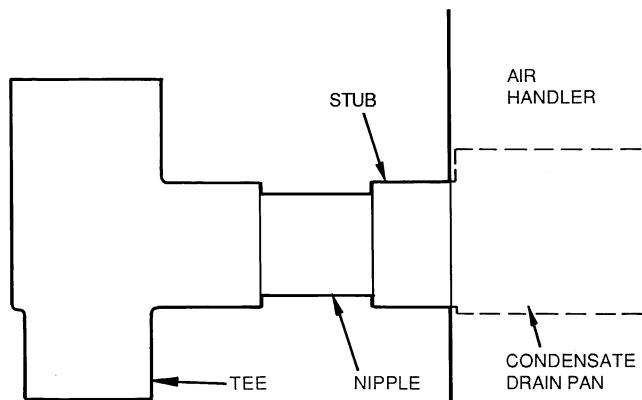

Fig. 2 — Install Nipple and Tee

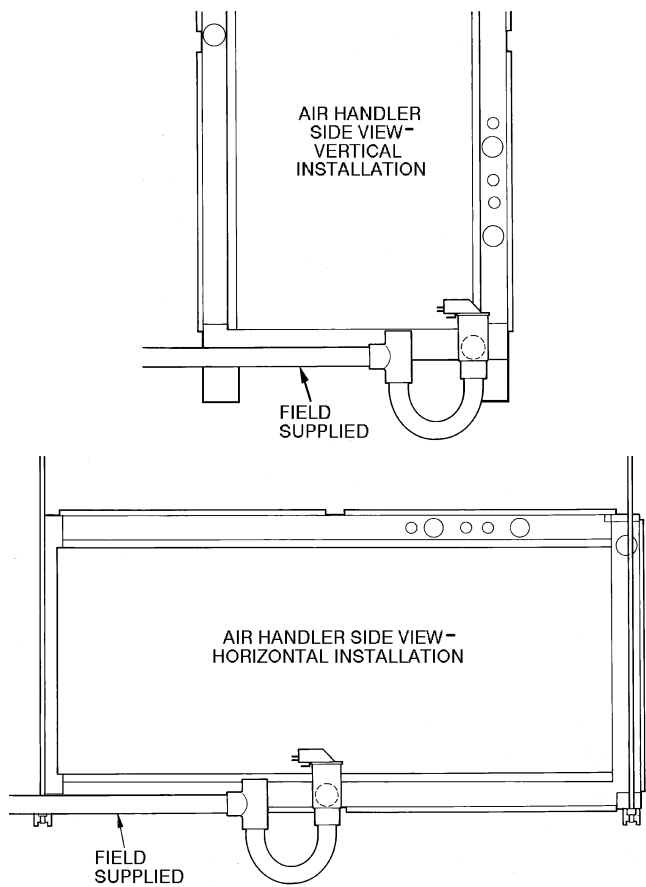

Fig. 3 — Installing Trap and Drain Line

Wire Overflow Switch Assembly — The switch shuts off the air handler fan(s) and can also be used to trigger a field-supplied alarm, light, or similar device. See Fig. 4.

CHILLED WATER UNITS — For air handlers with chilled water coils, the switch can be wired in series with the unit's indoor fan contactor coil. If the trap becomes plugged, the switch interrupts power to the coil and turns off the unit fan. Refer to Fig. 4 and 5 and wire the switch as follows:

1. Disconnect all power from unit and remove access panel on control box side of unit.
2. Locate wiring harness; quick-connects on one end of harness are for connection to switch.
3. Connect white wire from wiring harness to Common terminal on switch; connect red wire to Normally Closed terminal and black wire to Normally Open terminal. See Fig. 5.
4. Route other end of wiring harness through knockout in corner post of air handler to terminal strip on control box.
5. Strip white and red wire ends.
6. Remove indoor fan wire from thermostat at terminal G and connect to the white wire with a field-supplied wire nut. See Fig. 5.
7. Connect red wire to terminal G on unit terminal strip.
8. Black wire can be connected to alarm, bell, light, or similar device to indicate that condensate is not draining correctly from trap. Cap wire if switch is not connected to an alarm.
9. Secure wiring harness with wire ties. Ensure wires inside the unit do not interfere with fans or other internal components. Replace access panel and restore unit power.

DIRECT EXPANSION UNITS — For air handlers with direct expansion coils, the overflow shutoff switch can be wired in series with the condensing unit control circuit. A 24-v relay is also supplied with the kit for this application. If the drain pan trap on the air handler becomes plugged, the overflow switch interrupts power to the condensing unit and indoor fan control, turning off the system, shutting off the condensing unit's compressors and preventing the air handler drain pan from overflowing.

Refer to Fig. 4 and 6 and wire the switch as follows:

1. Disconnect all power from unit and remove access panel on control box side of unit.
2. Locate wiring harness; quick-connects on one end of harness are for connection to switch.
3. Connect white wire from wiring harness to Common terminal on switch; connect red wire to Normally Closed terminal and black wire to Normally Open terminal. See Fig. 6.
4. Route other end of wiring harness through knockout in corner post of air handler to terminal strip on control box.
5. Strip white and red wire ends.
6. Remove indoor fan wire from thermostat at terminal G and connect to the white wire with a field-supplied wire nut. See Fig. 6.
7. Connect red wire to terminal G on unit terminal strip.
8. Connect black wire to coil terminal C1 on supplied relay. Relay can be mounted in or near the air handler or condensing unit.

9. If alarm, bell, light, or similar device is used, wire the device between normally open terminal on switch and terminal C on the air handler's control box.
10. Complete wiring of relay as shown in Fig. 6. Using field-supplied wire, connect relay terminals 2 and 5 to the condensing unit, terminals 1 and 4 to thermostat terminals Y1 and Y2, and coil terminal C2 to common terminal C2 at thermostat or air handler.
11. Secure wiring harness with wire ties. Ensure wires inside the unit do not interfere with fans or other internal components. Replace access panel and restore unit power.

Verify Operation — With unit power on, set the thermostat fan switch to ON. Ensure fan is running. With a screwdriver, carefully lift switch arm or float mechanism on overflow switch to activate switch.

Once the switch is activated, the air handler fan immediately turns off. For direct expansion systems, condensing unit also shuts off. Field-supplied alarm (if present) is activated. If fan does not shut off, recheck wiring. Once operation is verified, release switch arm or float mechanism.

Maintenance — Inspect clear portion of trap periodically to ensure it is clean and unrestricted. Keep supplied cleaning brush near trap. If cleaning is required, remove plug from top of tee and insert brush for cleaning.

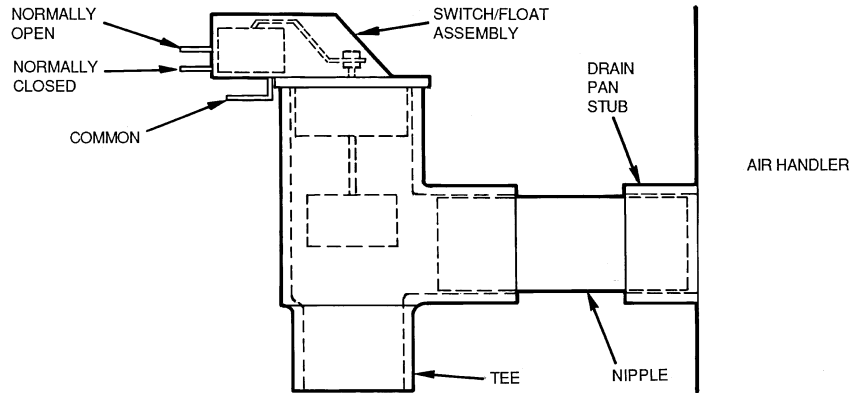
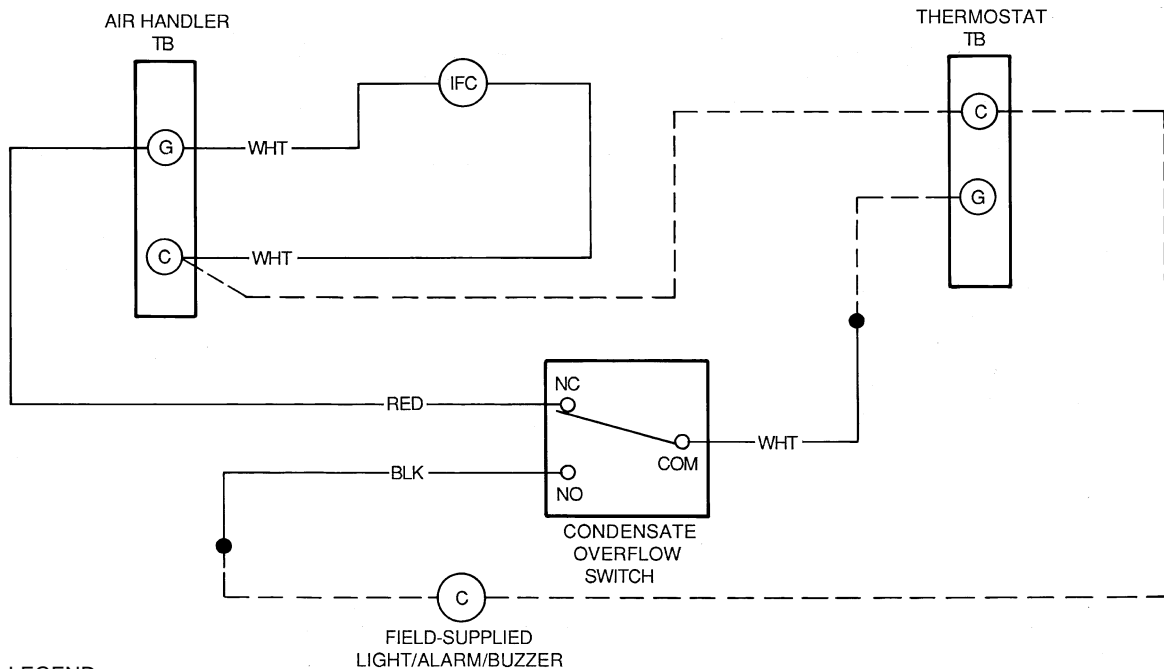
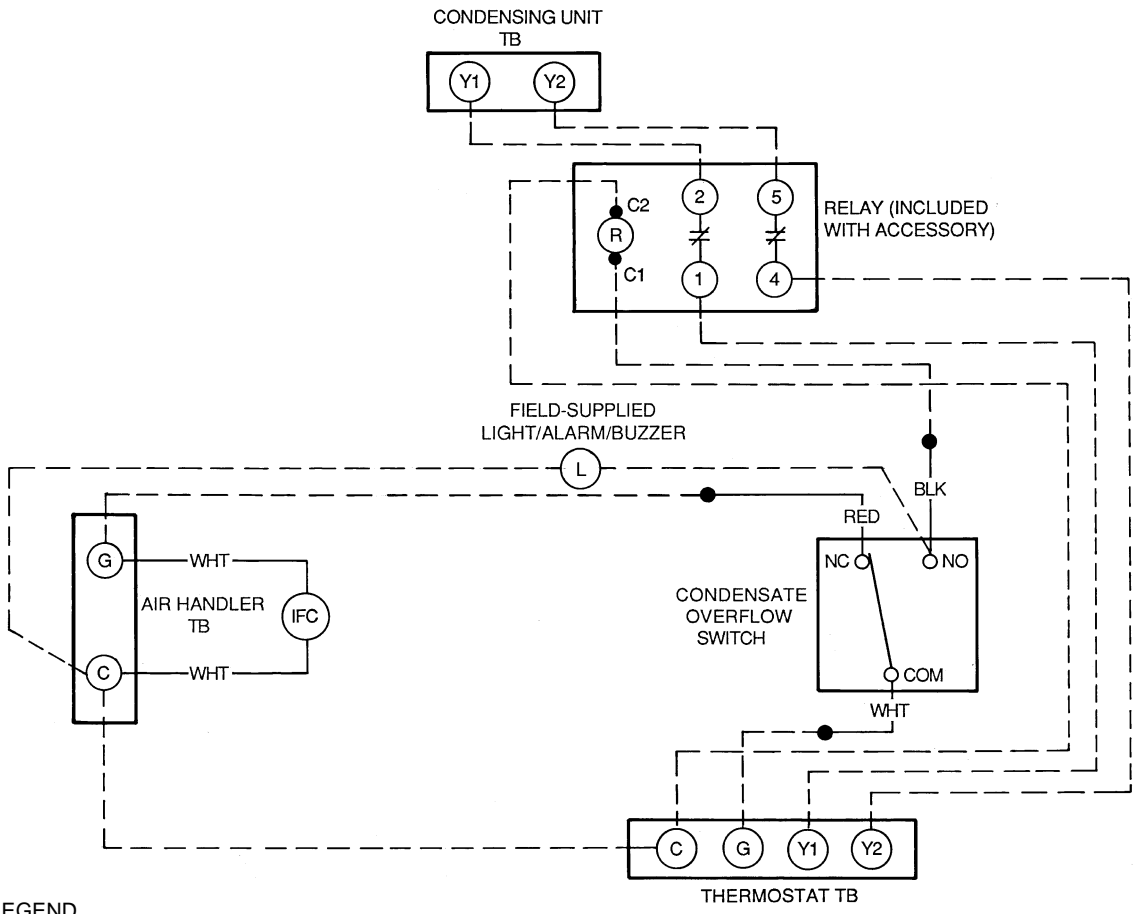

Fig. 4 — Overflow Switch/Float Assembly



- LEGEND**
- COM** — Common
 - IFC** — Indoor Fan Contactor
 - NC** — Normally Closed
 - NO** — Normally Open
 - TB** — Terminal Block
 - Field Wiring

Fig. 5 — Overflow Switch Wiring — Chilled Water Units



LEGEND

- COM — Common
- IFC — Indoor Fan Contactor
- NC — Normally Closed
- NO — Normally Open
- TB — Terminal Block
- Field Wiring

Fig. 6 — Overflow Switch Wiring — Direct Expansion Units