

53DS-900---077
53DS-900---078

HORIZONTAL DISCHARGE SYSTEMS

Wall Mounting Kit Accessory

Size 018-060 Cooling-Only and Heat Pump Units

Installation Instructions

GENERAL

These instructions cover the accessory wall mounting kit installation. The kit is provided for mounting cooling only, multi-split, and heat pump units to a wall due to space limitations.

IMPORTANT: Read these installation instructions **thoroughly** before starting installation.

Refer to Table 1 for kit contents and usage.

Table 1—KIT CONTENTS AND USAGE

KIT CONTENTS*		MOUNTING KIT PART NUMBER	USAGE
No.	Items		
2	Long Bracket Section	53DS-900---077	24AHA418, 024 25HHA418, 024 38HDF018-030 38HDR018, 024 38QRF018-030
2	Horizontal Bracket Section		38QRR018, 024 124A_S018, 024 224A_S018, 024 538A_R018, 024 538B_R018, 024
2	Angled Bracket Section		538E_F018-030 538Q_F018-030
6	Wall Lag Bolts		
6	Lag Bolt Washers		
6	Wall Lag Bolt Shields (Anchors)	53DS-900---078 +	24AHA430-060 25HHA430-060 38HDF036 38HDR030-060 38QRF036
4	Mounting Feet Bolts (1 in.)		38QRR030-060 124A_S030-060 224A_S030-060 538A_R030-060 538B_R030-060
10	Bracket Assy. Bolts (3/4 in.)		538E_F036 538Q_F036
14	Lock nuts		
14	Star Washers		
14	Flat Washers		

*The contents for both kits are the same; however, the items are different sizes for specific applications.

SAFETY CONSIDERATIONS

Installation of this equipment can be hazardous due to system pressures, electrical components and equipment location. Only trained, qualified installers and service technicians should install, start up and service this equipment. Observe all applicable precautions.

Improper installation, adjustment, alteration, service, maintenance, or use can cause explosion, fire, electrical shock, or other conditions which may cause personal injury or property damage. Consult a qualified installer, service agency, or your distributor or branch for information or assistance. The qualified installer or agency must use factory-authorized kits or accessories when modifying this product. Refer to the individual instructions packaged with kits or accessories when installing.

Follow all the safety codes. Wear safety glasses and work gloves. Use quenching cloth for brazing operations. Have fire extinguisher available. Read these instructions thoroughly and follow all warnings or cautions attached to the unit. Consult local building codes and National Electrical Code (NEC) for special requirements.

Recognize safety information. This is the safety-alert symbol . When you see this symbol on the unit and in instruction manuals, be alert to the potential for personal injury.

Understand the signal words **DANGER**, **WARNING**, **CAUTION**, and **NOTE**. These words are used with the safety-alert symbol. **DANGER** identifies the most serious hazards which **will** result in severe personal injury or death. **WARNING** signifies hazards which **could** result in personal injury or death. **CAUTION** is used to identify unsafe practices which **may** result in minor personal injury or product and property damage. **NOTE** is used to highlight suggestions which **will** result in enhanced installation, reliability, or operation.

 **WARNING**

ELECTRICAL SHOCK HAZARD

Failure to follow this warning could result in personal injury or death.

Before installation, always check to be sure main power to system is **OFF**.

INSTALLATION

1. Unpack accessory from carton. Ensure contents are not damaged or missing. See Table 1.
2. Select a mounting location on the wall. The location must allow for use of wall studs for mounting security. Check the local building codes and building construction to ensure that there is adequate wall strength to support the mounted unit. The location must also allow for condensate drainage from the unit. Ensure this drainage does not cause a problem for the area beneath the unit.

IMPORTANT: Ensure the outdoor unit will be mounted in a location that allows proper airflow. Observe the clearance requirements in the Installation Instructions for the specific outdoor unit being installed.

IMPORTANT: Do not drill new holes in the bracket assembly.

- Use the enclosed vertical bracket sections as a template for marking the mounting kit location on the wall. Both long bracket sections must line up with the middle and coil end mounting feet of the unit (see Fig. 1).

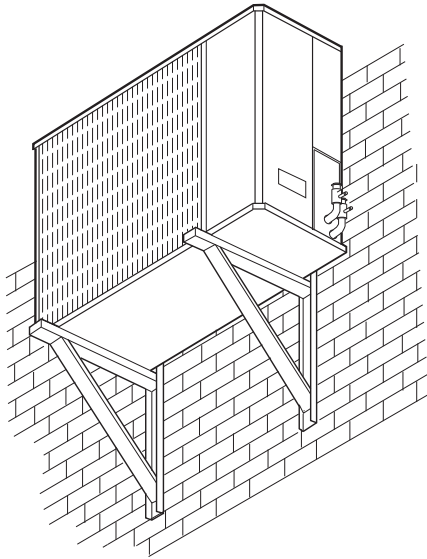

NOTE: Unit must be at least 6 in. (152.4 mm) from wall.

Fig. 1 – Typical Installation (Diagrammatic)

D06006

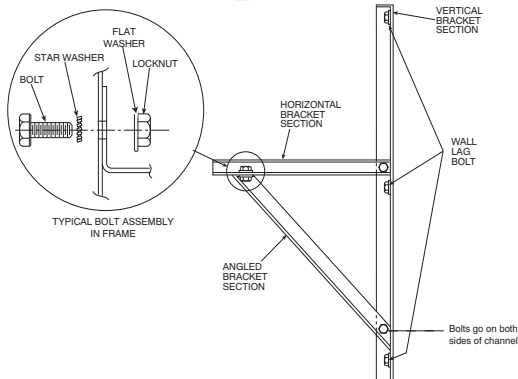

**Fig. 2 – Assembled Mounting Kit
(One Section, Diagrammatic)**

- Drill 6 mounting holes in marked-off locations on the wall. For wood wall mounting, drill 5/16-in. diameter holes. For masonry wall mounting, drill 5/8-in. diameter holes and insert 3/8-in. steel shields (anchors).
- Assemble the bracket sections as shown in Fig. 2, using bracket assembly bolts, lockwashers and bracket assembly locknuts. Do not tighten the bracket assembly bolts until the assembled kit is mounted on the wall. Mount the bracket assembly to the wall as shown in Fig. 2, using the 6 wall lag bolts and washers provided. Once mounted, tighten the bracket assembly bolts securely at all six mounting locations.
- Check that all bracket assembly sections are secure.

⚠ CAUTION

EQUIPMENT DAMAGE HAZARD

Failure to follow this caution may result in equipment and/or property damage.

To avoid damage to the wall or unit, check to be sure that all accessory parts are fastened tightly before mounting the unit on the wall brackets.

- Mount the unit on the wall brackets using the 1 in. (25.4 mm) mounting feet bolts and mounting feet locknuts provided. Tighten with the mounting feet locknuts. Use 2 bolts on the coil end of the unit, and 2 bolts beneath the compressor section (see Fig. 2, 3 and 4).

Side View (Wall Bracket)

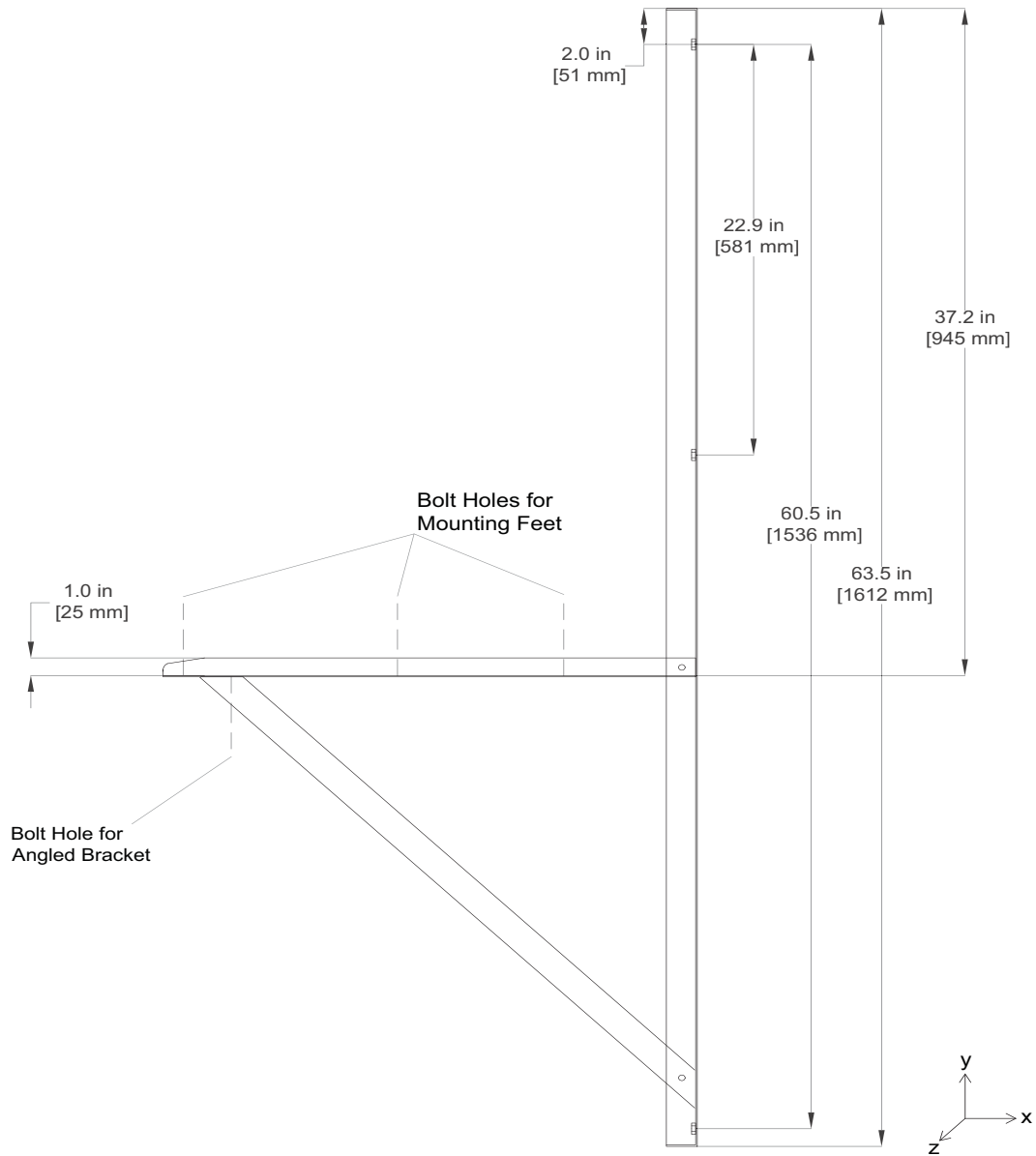

Top View (Horizontal Section)

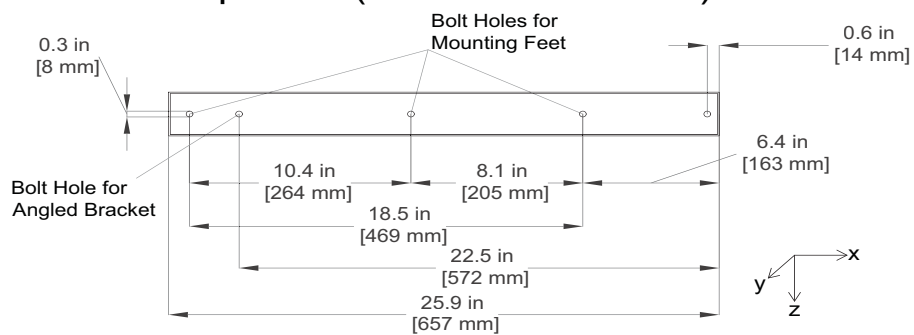

Fig. 3 – 53DS-900---077 Dimensional Drawing

Side View (Wall Bracket)

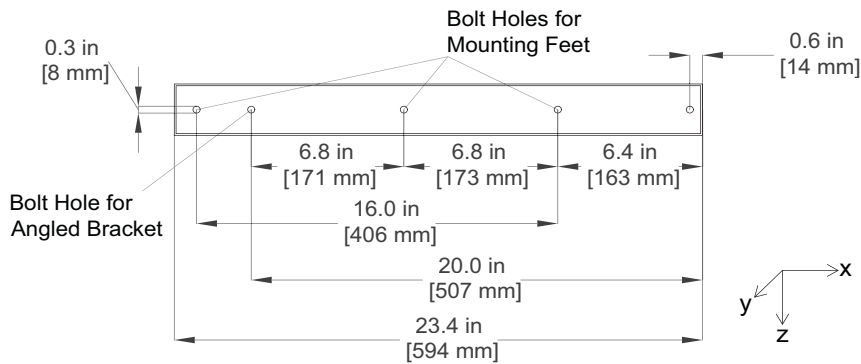
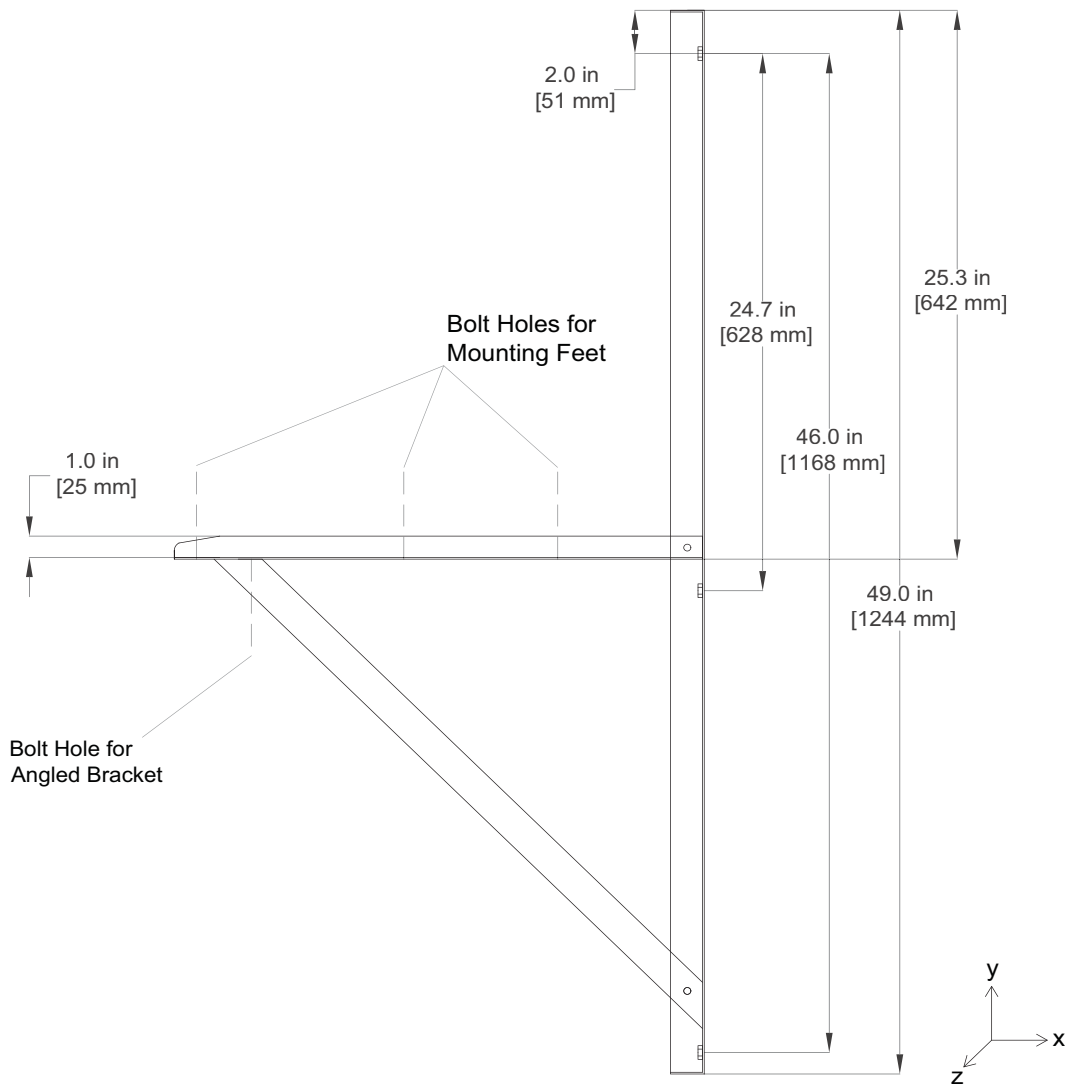

Fig. 4 – 53DS-900---078 Dimensional Drawing