

25HCE4

**Comfort™ 14 Heat Pump
with Puron® Refrigerant
1-1/2 To 5 Nominal Tons**



Turn to the experts

Product Data



Comfort
SERIES

Carrier heat pumps with Puron® refrigerant provide a collection of features unmatched by any other family of equipment. The 25HCE4 has been designed utilizing Carrier's non-ozone depleting Puron® refrigerant.

NOTE: Ratings contained in this document are subject to change at any time. Always refer to the AHRI directory (www.ahridirectory.org) for the most up-to-date ratings information.

Industry leading Features / Benefits

Efficiency

- 14 SEER / 11.0 - 11.5 EER / 8.2 HSPF
- Microtube Technology™ refrigeration system
- Indoor air quality accessories available

Sound

- Sound level as low as 69 dBA
- Sound levels as low as 68 dBA with accessory sound blanket

Comfort

- System supports programmable or standard thermostat controls

Reliability

- Non-ozone depleting Puron® refrigerant
- Scroll compressor
- Internal pressure relief valve
- Internal thermal overload
- Loss of charge switch
- Filter drier
- Balanced refrigeration system for maximum reliability

Durability

WeatherArmor™ protection package:

- Solid, durable sheet metal construction
- Dense wire coil guard
- Baked-on powder paint

Applications

- Long-line - up to 250 feet (76.20 m) total equivalent length, up to 200 feet (60.96 m) condenser above evaporator, or up to 80 ft. (24.38 m) evaporator above condenser (See Longline Guide for more information.)
- Low ambient cooling (down to -10°F/-23.3°C) with accessory kit

Model Number Nomenclature

1	2	3	4	5	6	7	8	9	10	11	12	13
N	N	A	A	A/N	N	N	N	A/N	A/N	A/N	N	N
2	5	H	C	E	4	3	6	A	P	0	3	0
Product Series	Product Family		Tier	Major Series	SEER	Cooling Capacity		Grille Variations	Variation	Outdoor Tube	Voltage	Minor Series
25 = HP	H = RES HP	C=Comfort	E = Puron	4=14 SEER			A=Dense Grille	0=Not Defined P=No High Pressure Switch	0=Copper L = Aluminum	3=208-230-1 5=208/230-3 6=460/3	0, 1, 2...	



Use of the AHRI Certified TM Mark indicates a manufacturer's participation in the program For verification of certification for individual products, go to www.ahridirectory.org.



Standard Features

Feature	18	24	30	36	42	48	60
Puron Refrigerant	X	X	X	X	X	X	X
Scroll Compressor	X	X	X	X	X	X	X
Field Installed Filter Drier	X	X	X	X	X	X	X
Front Seating Service Valves	X	X	X	X	X	X	X
Internal Pressure Relief Valve	X	X	X	X	X	X	X
Internal Thermal Overload	X	X	X	X	X	X	X
Long Line capability	X	X	X	X	X	X	X
Low Ambient cooling capability with Kit	X	X	X	X	X	X	X
Suction Line Accumulator	X	X	X	X	X	X	X
Loss of Charge Switch	X	X	X	X	X	X	X
Ball Bearing Fan Motor	X	X	X	X	X	X	X

X = Standard

Physical Data

UNIT SIZE - Series	18-30	24-30	30-30	36-31, 51,61 36L-30	42-30 42L-30	48-30, 50, 60	60-30	60-50, 60
Compressor Type	Scroll							
REFRIGERANT	Puron® (R-410A)							
Control	TXV (Puron Hard Shutoff)							
Outdoor Heating Piston #	42	46	49	57	61	65	78	78
Charge lb (kg)	5.30 (2.4)	5.60 (2.5)	6.40 (2.9)	7.67 (3.48)	8.25 (3.74)	8.68 (3.94)	10.60 (4.81)	10.60 (4.81)
COND FAN	Forward Swept or Propeller Type, Direct Drive							
Air Discharge	Vertical							
Motor HP	1/12	1/10	1/4	1/5	1/4	1/4	1/4	1/4
Motor RPM	1100	1100	1100	1100	1100	1100	800	800
CFM	1700	2195	3365	3165	3800	3365	4470	4470
VALVE CONNECT. (In. ID)								
Vapor	5/8	5/8	3/4	3/4	7/8	7/8	7/8	7/8
Liquid	3/8							
REFRIGERANT TUBES* (In. OD)								
Rated Vapor	5/8	5/8	3/4	3/4	7/8	7/8	1-1/8	1-1/8
Max Liquid Line	3/8							

*. Units are rated with 25 ft (7.6 m) of lineset length. See Vapor Line Sizing and Cooling Capacity Loss table when using other sizes and lengths of lineset.

Note: See unit Installation Instruction for proper installation.

Vapor Line Sizing and Cooling Capacity Loss

Acceptable vapor line diameters provide adequate oil return to the compressor while avoiding excessive capacity loss. The suction line diameters shown in the chart below are acceptable for HP systems with Puron refrigerant:

Vapor Line Sizing and Cooling Capacity Losses - Puron Refrigerant 1- Stage Heat Pump Applications

Unit Nominal Size (Btuh)	Acceptable Vapor Line Diameters (In. OD)	Cooling Capacity Loss (%) Total Equivalent Line Length (ft)										
		Standard Application				Long Line Application Requires Accessories						
		25 (7.62)	50 (15.2)	80 (24.4)	80+ (24.4+)	100 (30.48)	125 (38.10)	150 (45.72)	175 (53.34)	200 (60.96)	225 (68.58)	250 (76.20)
18,000	1/2	1	2	3	3	4	6	7	8	9	10	12
	5/8	0	0	1	1	1	1	2	2	3	3	3
24,000	5/8	0	1	1	1	2	3	3	4	4	5	6
	3/4	0	0	0	0	0	1	1	1	1	1	2
30,000	5/8	1	2	3	3	3	4	5	6	7	8	9
	3/4	0	0	1	1	1	1	2	2	2	3	3
	7/8	0	0	0	0	0	1	1	1	1	1	1
36,000	5/8	1	2	4	4	5	6	7	9	10	11	13
	3/4	0	0	1	1	1	2	2	3	3	4	4
	7/8	0	0	0	0	0	1	1	1	1	2	2
42,000	3/4	0	1	2	2	2	3	4	4	5	6	6
	7/8	0	0	1	1	1	1	2	2	2	3	3
48,000	3/4	0	1	2	2	3	4	5	5	6	7	8
	7/8	0	0	1	1	1	2	2	2	3	3	4
60,000	3/4	1	2	4	4	5	6	7	9	10	11	12
	7/8	0	1	2	2	2	3	4	4	5	5	6
	1 1/8	0	0	0	0	1	1	1	1	1	1	2

Standard Length = 80 ft. (24.4 m) or less total equivalent length

Applications in this area are long line. Accessories are required as shown recommended on Long Line Application Guidelines

Applications in this area may have height restrictions that limit allowable total equivalent length, when outdoor unit is below indoor unit See Long Line Application Guidelines

Refrigerant Piping Length Limitations

Maximum Line Lengths:

The maximum allowable total equivalent length for heat pumps varies depending on the vertical separation. See the tables below for allowable lengths depending on whether the outdoor unit is on the same level, above or below the indoor unit.

Maximum Line Lengths for Heat Pump Applications

	MAXIMUM ACTUAL LENGTH* ft (m)	MAXIMUM EQUIVALENT LENGTH{ ft (m)	MAXIMUM VERTICAL SEPARATION ft (m)
Units on equal level	200 (61)	250 (76.2)	N/A
Outdoor unit ABOVE indoor unit	200 (61)	250 (76.2)	200 (61)
Outdoor unit BELOW indoor unit	See Table 'Maximum Total Equivalent Length: Outdoor Unit BELOW Indoor Unit'		

. Maximum actual length not to exceed 200 ft (61 m)

Maximum Total Equivalent Length* { - Outdoor Unit BELOW Indoor Unit

Size	Liquid Line Diameter w/ TXV	HP with Puron® Refrigerant - Maximum Total Equivalent Length Vertical Separation ft (m) Outdoor unit BELOW indoor unit;						
		0-20 (0 - 6.1)	21-30 (6.4 - 9.1)	31-40 (9.4 - 12.2)	41-50 (12.5 - 15.2)	51-60 (15.5 - 18.3)	61-70 (18.6 - 21.3)	71-80 (21.6 - 24.4)
18,000	3/8	250*	250*	250*	250*	250*	250*	250*
24,000	3/8	250*	250*	250*	250*	250*	250*	250*
30,000	3/8	250*	250*	250*	250*	250*	250*	250*
36,000	3/8	250*	250*	250*	250*	250*	250*	250*
42,000	3/8	250*	250*	250*	250*	250*	250*	150
48,000	3/8	250*	250*	250*	250*	230	160	—
60,000	3/8	250*	225*	190	150	110	—	—

*. Total equivalent length accounts for losses due to elbows or fitting. See the Long Line Guideline for details.

— = outside acceptable range

Long Line Applications

An application is considered Long Line when the refrigerant level in the system requires the use of accessories to maintain acceptable refrigerant management for systems reliability. Defining a system as long line depends on the liquid line diameter, actual length of the tubing, and vertical separation between the indoor and outdoor units.

For Heat Pump systems, the chart below shows when an application is considered Long Line. Beyond these lengths, long line accessories are required:

HP with Puron Refrigerant Long Line Description ft (m) Beyond these lengths, long line accessories are required

Liquid Line Size	Units On Same Level	Outdoor Below Indoor	Outdoor Above Indoor
3/8	80 (24.4)	20 (6.1) vertical or 80 (24.4) total	80 (24.4)

Note: See Long Line Guideline for details

Accessories

ORDER NUMBER	KIT DESCRIPTION	Unit Size-Voltage, Series												
		18-30	24-30	30-30	36-31 36L-30	36-51	36-61	42-30 42L-30	48-30	48-50	48-60	60-30	60-50	60-60
KAACH1601AAA	CRANKCASE HTR							X	X			X		
KAACH1701AAA	CRANKCASE HTR	X	X	X	X	S	S			S	S		S	S
KAACS0201PTC	KIT PTC	X	X	X	X			X	X			X		
KAATD0101TDR	TIME DELAY RELAY	X	X	X	X	X	X	X	X	X	X	X	X	X
KHAIR0201AAA	ISOLATION RELAY	X	X	X	X	X	X	X	X	X	X	X	X	X
KHALS0401LLS	SOLENOID VALVE	X	X	X	X	X	X	X	X	X	X	X	X	X
KHASS0606MPK	SNOW STAND	X	X	X	X	X	X	X	X	X	X	X	X	X
KSACY0101AAA	CYCLE PROT	X	X	X	X	X	X	X	X	X	X	X	X	X
KSAFT0101AAA	FREEZE TSTAT	X	X	X	X	X	X	X	X	X	X	X	X	X
KSAHI0401PUR	HIGH PRESSURE SWITCH	X	X	X	X	X	X	X	X	X	X	X	X	X
KSAHS2501AAA	HARD START	X	X	X	X							X		
KSAHS2701AAA	HARD START							X	X					
KSALA0301410	LOW AMBIENT COOLING PRESSURE SWITCH	X	X	X	X	X	X	X	X	X	X	X	X	X
KSALA0601AAA	MOTORMASTER*	X	X	X	X	X		X	X	X		X	X	
KSALA0701AAA	MOTORMASTER*						X				X			X
KSASF0201AAA	SUPPORT FEET	X	X	X	X	X	X	X	X	X	X	X	X	X
KSASH2301COP	SOUND BLANKET	X	X	X	X	X	X							
KSASH2401COP	SOUND BLANKET							X	X	X	X	X	X	X
KSATX0201PUR	TXV KIT	X	X	X										
KSATX0301PUR	TXV KIT				X	X	X	X						
KSATX0401PUR	TXV KIT								X	X	X	X	X	X
KSBTX0201PUR	TXV KIT	X	X	X										
KSBTX0301PUR	TXV KIT				X	X	X	X						
KSBTX0401PUR	TXV KIT								X	X	X	X	X	X

X = Accessory

S = Standard

* If ball bearing fan motor accessory is not listed, the unit comes factory supplied with a ball bearing motor and accessory motor is not required

Accessory Usage Guideline

Accessory	REQUIRED FOR LOW-AMBIENT COOLING APPLICATIONS (Below 55°F / 12.8°C)	REQUIRED FOR LONG LINE APPLICATIONS*	REQUIRED FOR SEA COAST APPLICATIONS (Within 2 miles / 3.22 km)
Accumulator	Standard	Standard	Standard
Ball Bearing Fan Motor	Yes†	No‡	No‡
Compressor Start Assist Capacitor and Relay	Yes**	Yes**	No**
Crankcase Heater	Yes‡	Yes‡	No‡
Evaporator Freeze Thermostat	Yes	No	No
Hard Shutoff TXV	Yes	Yes	No
Isolation Relay	Yes	No	No
Liquid Line Solenoid Valve	No	See Long-Line Application Guideline	No
Motor Master® Control or Low Ambient Cooling Pressure Switch	Yes	No	No
Support Feet	Recommended	No	Recommended

*.*For tubing line sets between 80 and 200 ft. (24.38 and 60.96 m) and/or 20 ft. (6.09 m) vertical differential, refer to Residential Split-System Longline Application Guideline.

†.Additional requirement for Low-Ambient Controller (full modulation feature) MotorMaster® Control.

‡.Standard for 3 phase units only

**..Not required for 3-phase units.

Accessory Description and Usage (Listed Alphabetically)

1. Ball-Bearing Fan Motor

A fan motor with ball bearings which permits speed reduction while maintaining bearing lubrication.

Usage Guideline:

Required on all units when using MotorMaster®

2. Compressor Start Assist - Capacitor and Relay

Start capacitor and relay gives a hard boost to compressor motor at each start up.

Usage Guideline:

Required for reciprocating compressors in the following applications:

Long Line

Low ambient cooling

Hard shut off expansion valve on indoor coil

Liquid line solenoid on indoor coil

Required for single-phase scroll compressors in the following applications:

Long line

Low ambient cooling

Suggested for all compressors in areas with a history of low voltage problems.

3. Compressor Start Assist — PTC Type

Solid state electrical device which gives a soft boost to the compressor at each start-up.

Usage Guideline:

Suggested for single phase unit installations with marginal power supply.

4. Crankcase Heater

An electric resistance heater which mounts to the base of the compressor to keep the lubricant warm during off cycles. Improves compressor lubrication on restart and minimizes the chance of liquid slugging.

Usage Guideline:

Required in low ambient cooling applications.

Required in long line applications.

Suggested in all commercial applications.

5. Evaporator Freeze Thermostat

An SPST temperature-actuated switch that stops unit operation when evaporator reaches freeze-up conditions.

Usage Guideline:

Required when low ambient cooling kit has been added.

6. Isolation Relay

An SPDT relay which switches the low-ambient controller out of the outdoor fan motor circuit when the heat pump switches to heating mode.

Usage Guideline:

Required in all heat pumps where low ambient cooling kit has been added.

7. Liquid-Line Solenoid Valve (LLS)

An electrically operated shutoff valve which stops and starts refrigerant liquid flow in response to compressor operation. It is to be installed at the outdoor unit to control refrigerant off cycle migration in the heating mode.

Usage Guideline:

An LLS is required in all long line heat pump applications to control refrigerant off cycle migration in the heating mode. See Long Line Guideline.

8. Low-Ambient Cooling Pressure Switch Kit

A long life pressure switch which is mounted to outdoor unit service valve. It is designed to cycle the outdoor fan motor in order to maintain head pressure within normal operating limits. The control will maintain working head pressure at low-ambient temperatures down to 0°F (-18°C) when properly installed.

Usage Guideline:

A Low-Ambient Cooling Pressure Switch or MotorMaster® low-ambient Controller must be used when cooling operation is used at outdoor temperatures below 55°F (12.8°C).

9. MotorMaster® Low-Ambient Cooling Controller

A fan-speed control device activated by a temperature sensor, designed to control condenser fan motor speed in response to the saturated, condensing temperature during operation in cooling mode only. For outdoor temperatures down to -10°F (-23.3°C), it maintains condensing temperature at 100°F ±10°F (37.8°C ± 6.5°C).

Usage Guideline:

A MotorMaster® low ambient Controller or low-ambient pressure switch must be used when cooling operation is used at outdoor temperatures below 55°F (12.8°C).

Suggested for all commercial applications.

Accessory Description and Usage (Listed Alphabetically) continued

10. Outdoor Air Temperature Sensor

Designed for use with Carrier Thermostats listed in this publication. This device enables the thermostat to display the outdoor temperature. This device also is required to enable special thermostat features such as auxiliary heat lock out.

Usage Guideline:

Suggested for all Carrier thermostats listed in this publication.

11. Snow Stand Rack

Coated wire rack which supports unit 18 in. (457.2 mm) above mounting pad to allow for drainage from unit base.

Usage Guideline:

Suggested in the following applications:

Heat pump installations in heavy snowfall areas.

Heat pump installations in snow drift locations.

Heat pump installations in areas of prolonged subfreezing temperatures.

All commercial installations.

12. Sound Hood

Wraparound sound reducing cover for the compressor. Reduces the sound level by about 2 dBA.

Usage Guideline:

Suggested when unit is installed closer than 15 ft. (4.577 m) to quiet areas, bedrooms, etc.

Suggested when unit is installed between two houses less than 10 ft. (3.05 m) apart.

13. Thermostatic Expansion Valve (TXV) Bi-Flow

A modulating flow-control valve which meters refrigerant liquid flow rate into the evaporator in response to the superheat of the refrigerant gas leaving the evaporator.

Usage Guideline:

Accessory required to meet AHRI rating and system reliability, where indoor not equipped.

Required in all heat pump applications designed with Puron refrigerant.

14. Time-Delay Relay

An SPST delay relay which briefly continues operation of indoor blower motor to provide additional cooling after the compressor cycles off.

NOTE: Most indoor unit controls include this feature. For those that do not, use the guideline below.

Usage Guideline:

Accessory required to meet AHRI rating, where indoor not equipped.

Electrical Data

UNIT SIZE - Voltage, Series	V/PH	OPER VOLTS*		COMPR		FAN	MCA	MAX FUSE† or CKT BRK AMPS
		MAX	MIN	LRA	RLA	FLA		
18 - 30	208-230-1	253	197	48.0	9.00	0.50	11.8	20
24 - 30				62.9	10.90	0.60	14.2	25
30 - 30				72.5	13.50	1.40	18.3	30
36 - 31				75.0	15.10	1.10	20.0	30
36L-30				75.0	14.90	1.10	19.7	30
42 - 30				105.5	18.10	1.40	24.0	40
42L-30				105.5	16.20	1.40	21.7	30
48 - 30				108.0	19.00	1.40	25.2	40
60 - 30	208/230-3	253	187	144.2	24.40	1.52	32.0	50
36 - 51				70.0	8.46	1.10	11.7	20
48 - 50				123.0	10.44	1.40	14.5	25
60 - 50	460-3	506	414	110.0	15.96	1.52	21.5	30
36 - 61				31.0	3.85	0.60	5.4	15
48 - 60				60.0	6.00	0.77	8.3	15
60 - 60				52.0	7.75	0.77	10.5	15

*. Permissible limits of the voltage range at which the unit will operate satisfactorily

†. **Time-Delay fuse.

FLA—Full Load Amps

LRA—Locked Rotor Amps

MCA—Minimum Circuit Amps

RLA—Rated Load Amps

NOTE: Control circuit is 24-V on all units and requires external power source. Copper wire must be used from service disconnect to unit.

All motors/compressors contain internal overload protection.

Complies with requirements of ASHRAE Standards 90.1

A-Weighted Sound Power Without Sound Hood

UNIT SIZE-VOLTAGE, SERIES	STANDARD RATING (dBA)	TYPICAL OCTAVE BAND SPECTRUM (dB, without tone adjustment)						
		125 Hz	250 Hz	500 Hz	1000 Hz	2000 Hz	4000 Hz	8000 Hz
18-30	69	65	64	65	67	59	57	54
24-30	76	66	70	70	70	67	64	55
30-30	77	71	74	75	73	69	66	61
36-31, 51, 61, 36L-30	78	76	75	75	73	69	67	62
42-30, 42L-30	76	70	74	71	71	65	64	58
48-30, 50, 60	79	72	78	77	76	70	67	61
60-30	73	71	74	71	69	64	61	58
60-50, 60	76	73	74	72	72	69	64	63

NOTE: Tested in accordance with AHRI Standard 270-08 (not listed in AHRI).

A-Weighted Sound Power with Sound Hood

UNIT SIZE-VOLTAGE, SERIES	STANDARD RATING (dBA)	TYPICAL OCTAVE BAND SPECTRUM (dB, without tone adjustment)						
		125 Hz	250 Hz	500 Hz	1000 Hz	2000 Hz	4000 Hz	8000 Hz
18-30	68	66	65	64	65	59	56	52
24-30	74	67	70	70	68	65	61	56
30-30	77	72	74	75	72	69	66	60
36-31, 51, 61, 36L-30	78	76	76	76	73	69	65	60
42-30, 42L-30	74	71	74	70	70	65	62	56
48-30, 50, 60	79	73	79	77	75	70	67	61
60-30	73	72	75	70	68	63	60	55
60-50, 60	76	72	72	71	72	69	64	63

NOTE: Tested in accordance with AHRI Standard 270-08 (not listed in AHRI).

Charging Subcooling (TXV-Type Expansion Device)

UNIT SIZE-VOLTAGE	REQUIRED SUBCOOLING °F (°C)
18-30	11 (6.1)
24-30	11 (6.1)
30-30	10 (5.6)
36-31, 36L-30	10 (5.6)
36-51, 61	11 (6.1)
42-30	10 (5.6)
42L-30	11 (6.1)
48-30, 50, 60	14 (7.8)
60-30, 50, 60	15 (8.3)

HP Only Replacement with Piston Indoors

When the 25HCE4 is used as a replacement component in a system with a piston fan coil, use the indoor piston size specified below:

UNIT SIZE	PISTON SIZE		
	FB4CNF	FFM	FPMA
18	0.052	0.050	0.050
24	0.057	0.057	0.056
30	0.067	0.070	0.067
36	0.070	0.072	0.069
42	0.078		
48	0.084		
60			

■ = N/A

Dimensions

UNIT	SERIES	ELECTRICAL CHARACTERISTICS					A		B		C		D		E		F		G		H		I		J		K		OPERATING WEIGHT		SHIPPING WEIGHT		SHIPPING LENGTH / WIDTH (Sq.)		SHIPPING HEIGHT			
							INCH	MM	INCH	MM	INCH	MM	INCH	MM	INCH	MM	INCH	MM	INCH	MM	INCH	MM	INCH	MM	INCH	MM	INCH	MM	INCH	MM	INCH	MM	Lbs	Kgs	Lbs	Kgs	INCH	MM
25HCE418AP030011	0	Y	N	N	N	23	587.3	35	902.0	5/8	15.9	4	113.0	18	459.0	7	197.9	1	28.2	3	76.2	97.4	11	279.4	15	381.0	12	304.8	136	61.7	150	68.0	26	660.0	40	1034.8		
25HCE424AP030011	0	Y	N	N	N	25	654.0	35	902.0	5/8	15.9	4	113.0	18	459.0	7	197.9	1	28.2	3	76.2	97.4	12	304.8	15	381.0	11	279.4	16	406.4	158	71.7	175	79.4	34	870.0	37	947.9
25HCE430AP030011	0	Y	N	N	N	31	792.5	32	815.1	3/4	19.1	6	166.1	24	626.3	9	231.3	1	28.2	3	76.2	97.4	15	381.0	14	355.6	10	254.0	170	77.1	186	84.4	34	870.0	33	861.6		
25HCE436AP031011	1	Y	N	N	N	31	792.5	28	728.7	3/4	19.1	6	166.1	24	626.3	9	231.3	1	28.2	3	76.2	97.4	15	381.0	14	355.6	10	254.0	170	77.1	186	84.4	34	870.0	33	861.6		
25HCE436AP051011	1	N	Y	N	N	31	792.5	28	728.7	3/4	19.1	6	166.1	24	626.3	9	231.3	1	28.2	3	76.2	97.4	15	381.0	14	355.6	10	254.0	170	77.1	186	84.4	34	870.0	33	861.6		
25HCE436AP061011	1	N	N	Y	N	31	792.5	28	728.7	3/4	19.1	6	166.1	24	626.3	9	231.3	1	28.2	3	76.2	97.4	15	381.0	14	355.6	10	254.0	170	77.1	186	84.4	34	870.0	33	861.6		
25HCE436APL30011	0	Y	N	N	N	31	792.5	28	728.7	3/4	19.1	6	166.1	24	626.3	9	231.3	1	28.2	3	76.2	97.4	15	381.0	14	355.6	10	254.0	170	77.1	186	84.4	34	870.0	33	861.6		
25HCE442AP030011	0	Y	N	N	N	31	792.5	38	987.8	7/8	22.2	6	166.1	24	626.3	9	231.3	1	28.2	3	76.2	97.4	15	381.0	13	330.2	14	355.6	201	91.2	219	99.3	34	870.0	44	1120.7		
25HCE442APL30011	0	Y	N	N	N	31	792.5	38	987.8	7/8	22.2	6	166.1	24	626.3	9	231.3	1	28.2	3	76.2	97.4	16	406.4	17	431.8	190	86.0	207	93.9	34	870.0	44	1120.7				
25HCE448AP030011	0	Y	N	N	N	31	792.5	28	728.7	7/8	22.2	6	166.1	24	626.3	9	231.3	1	28.2	3	76.2	97.4	16	406.4	11	292.1	15	381.0	197	89.4	213	96.6	34	870.0	33	861.6		
25HCE448APL30011	0	N	Y	N	N	31	792.5	28	728.7	7/8	22.2	6	166.1	24	626.3	9	231.3	1	28.2	3	76.2	97.4	16	406.4	11	292.1	15	381.0	197	89.4	213	96.6	34	870.0	33	861.6		
25HCE448AP060011	0	N	N	Y	N	31	792.5	28	728.7	7/8	22.2	6	166.1	24	626.3	9	231.3	1	28.2	3	76.2	97.4	16	406.4	11	292.1	15	381.0	197	89.4	213	96.6	34	870.0	33	861.6		
25HCE460AP030011	0	Y	N	N	N	31	792.5	32	815.1	7/8	22.2	6	166.1	24	626.3	9	231.3	1	28.2	3	76.2	97.4	14	355.6	16	406.4	16	406.4	212	96.2	229	103.9	34	870.0	37	947.9		
25HCE460AP050011	0	N	Y	N	N	31	792.5	32	815.1	7/8	22.2	6	166.1	24	626.3	9	231.3	1	28.2	3	76.2	97.4	14	355.6	15	381.0	16	406.4	212	96.2	229	103.9	34	870.0	37	947.9		
25HCE460AP060011	0	N	N	Y	N	31	792.5	32	815.1	7/8	22.2	6	166.1	24	626.3	9	231.3	1	28.2	3	76.2	97.4	14	355.6	15	381.0	16	406.4	212	96.2	229	103.9	34	870.0	37	947.9		

208-230-1-60	Y=YES N=NO
208/230-3-60	
460-5-60	
575-5-60	

NOTES:

1. CENTER OF GRAVITY 

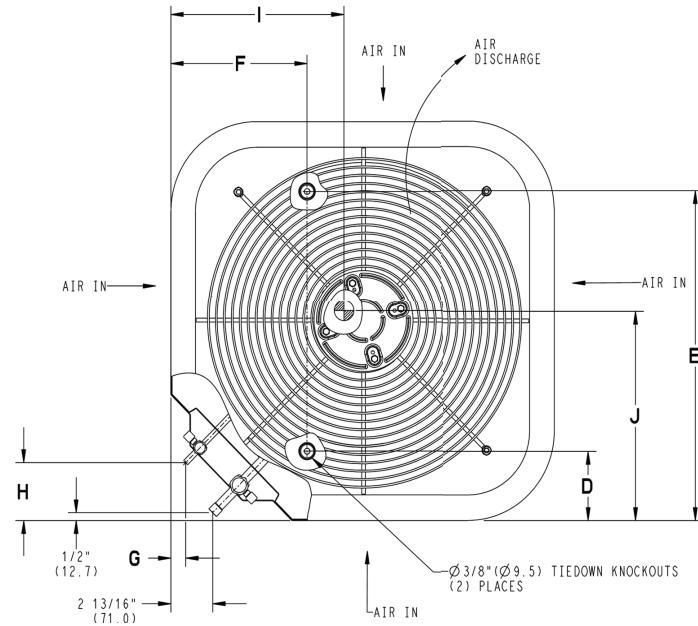
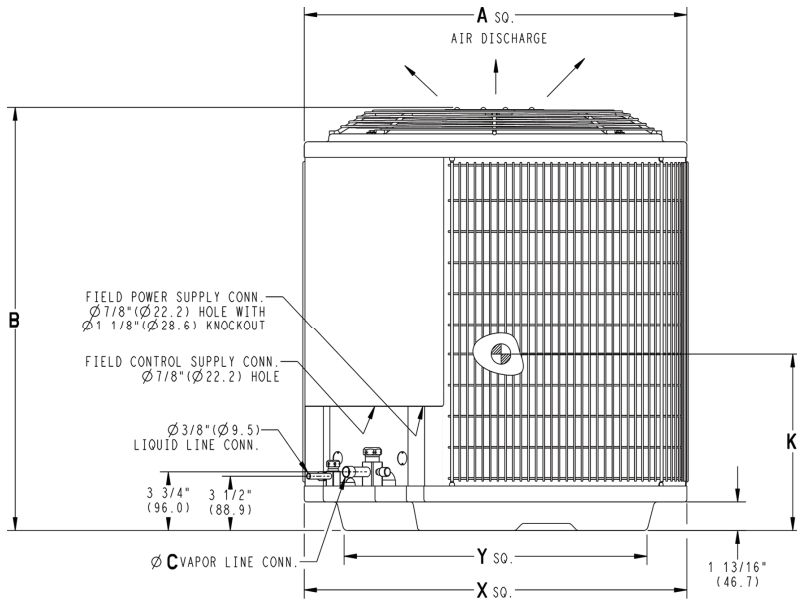

UNIT SIZE	"X"		"Y"	
	MINIMUM GROUND MOUNTING PAD APPLICATION DIMENSIONS		MINIMUM ROOF-TOP MOUNTING PAD APPLICATION DIMENSIONS	
18	23	587.3	17	454.6
24	25	654.0	20	518.5
30,36,42,48,60	31	792.5	22	583.2
-	35	889.0	26	679.7

NOTE: ALL DIMENSIONS IN INCH (MM)

U.S. ECCN: Not Subject to Regulation (N.S.R.)

Clearances

Clearances (various examples)

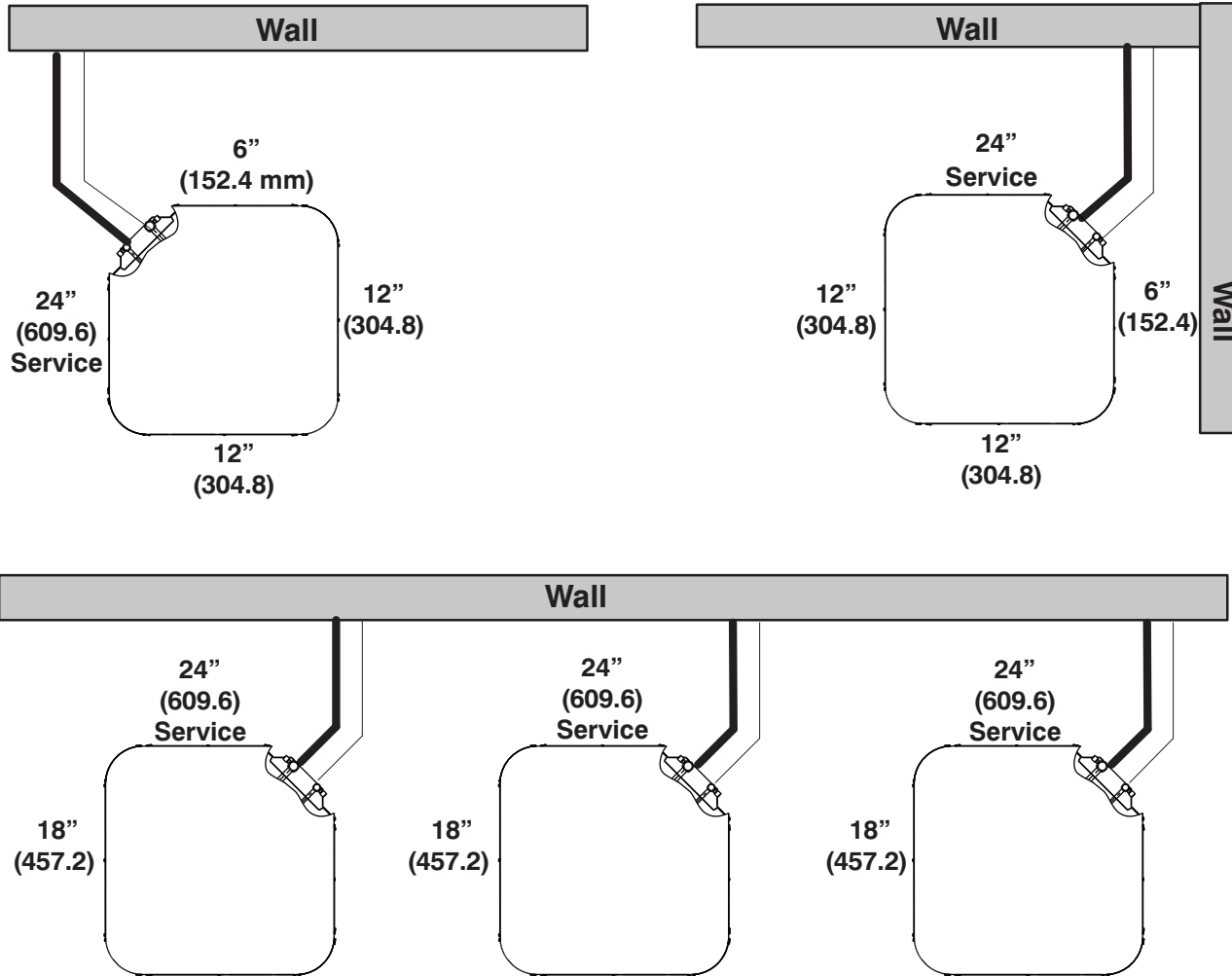

Note: Numbers in () = mm
Allow 48" above unit

IMPORTANT: When installing multiple units in an alcove, roof well, or partially enclosed area, ensure there is adequate ventilation to prevent re-circulation of discharge air.

Balance Point Worksheet

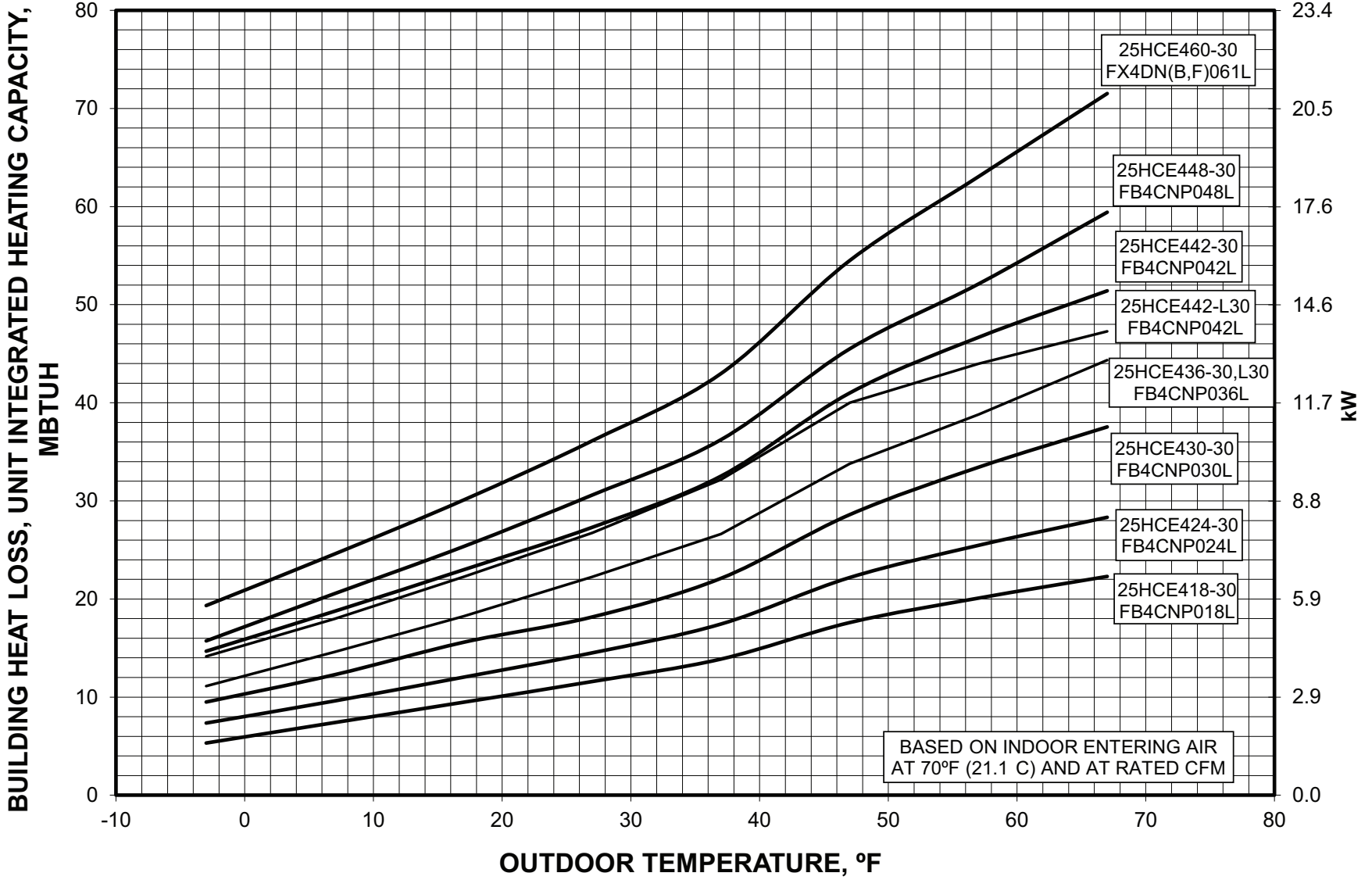

Manufacturer reserves the right to change, at any time, specifications and designs without notice and without obligations.

Tested AHRI Combination Ratings

NOTE: Ratings contained in this document are subject to change at any time.

For AHRI ratings certificates, please refer to the AHRI directory www.ahridirectory.org

Additional ratings and system combinations can be accessed via the Carrier database at: www.MyCarrierRatings.com

For performance data at specific application &/or design conditions with various indoor unit combinations, the equipment performance calculator can be accessed at: <http://rpmob.wrightsoft.com/>

Model Number	Indoor Coil Model Number	Cooling Capacity	EER	SEER	High Temp		HSPF	Low Temp	
					E Capacity	E COP		H Capacity	H COP
25HCE418AP030	FB4CNP018L	17,800	11.5	14	17,600	3.72	8.2	10,400	2.40
25HCE424AP030	FB4CNP030L	22,200	11.5	14	22,200	3.84	8.2	13,200	2.54
25HCE430AP030	FB4CNP030L	28,600	11.5	14	28,600	3.62	8.2	17,100	2.44
25HCE436AP031	FB4CNP036L	33,000	11.5	14	33,800	3.62	8.2	20,800	2.40
25HCE436APL30	FB4CNP036L	33,000	11.5	14	33,800	3.70	8.2	20,000	2.44
25HCE436AP051, 61	FB4CNP036L	33,000	11.0	14	33,000	3.64	8.2	20,800	2.46
25HCE442AP030	FB4CNP042L	40,000	11.5	14	41,000	3.62	8.2	25,200	2.50
25HCE442APL30	FB4CNP042L	40,000	11.5	14	40,000	3.58	8.2	24,400	2.50
25HCE448AP030, 50, 60	FB4CNP048L	46,000	11.5	14	45,500	3.64	8.2	27,800	2.56
25HCE460AP030, 50, 60	FX4DN(B,F)061L	57,000	11.5	14	54,500	3.70	8.2	33,000	2.56

Cooling Standard: 80°F (27°C) db 67°F (19°C) wb indoor entering air temperature and 95°F (35°C) db air entering outdoor unit.

High-Temp Heating Standard: 70°F (21°C) db indoor entering air temperature and 47°F (8°C) db 43°F (6°C) wb air entering outdoor unit.

Low-Temp Heating Standard: 70°F (21°C) db indoor entering air temperature and 17°F (-8°C) db 15°F (-9°C) wb air entering outdoor unit.

COP — Coefficient of Performance

EER — Energy Efficiency Ratio

HSPF — Heating Seasonal Performance Factor

SEER — Seasonal Energy Efficiency Ratio

Detailed Cooling Capacities[#]

EVAPORATOR AIR		CONDENSER ENTERING AIR TEMPERATURES °F (°C)																			
		75 (23.9)		85 (29.4)				95 (35)				105 (40.6)				115 (46.1)			125 (51.7)		
		CFM	EWB °F (°C)	Capacity MBtuh		Total Syst. KW**	Capacity MBtuh		Total Syst. KW**	Capacity MBtuh		Total Syst. KW**	Capacity MBtuh		Total Syst. KW**	Capacity MBtuh		Total Syst. KW**	Capacity MBtuh		Total Syst. KW**
Total	Sens†			Total	Sens†		Total	Sens†		Total	Sens†		Total	Sens†		Total	Sens†		Total	Sens†	
25HCE418-30 Outdoor Section With FB4CNP018L Indoor Section																					
525	72 (22.2)	21.99	11.23	1.19	20.64	10.68	1.36	19.27	10.11	1.54	17.87	9.55	1.75	16.42	8.98	1.98	14.95	8.40	2.24		
	67 (19.4)	19.94	13.74	1.18	18.72	13.15	1.35	17.47	12.55	1.53	16.18	11.95	1.74	14.86	11.33	1.97	13.51	10.71	2.22		
	63 (17.2)††	18.46	13.21	1.18	17.33	12.63	1.35	16.16	12.04	1.53	14.96	11.44	1.73	13.73	10.83	1.96	12.47	10.21	2.22		
	62 (16.7)	18.10	16.18	1.18	17.00	15.54	1.34	15.88	14.89	1.53	14.73	14.19	1.73	13.63	13.63	1.96	12.59	12.59	2.22		
	57 (13.9)	17.41	17.41	1.18	16.52	16.52	1.34	15.58	15.58	1.52	14.62	14.62	1.73	13.61	13.61	1.96	12.57	12.57	2.22		
600	72 (22.2)	22.45	11.80	1.20	21.05	11.23	1.37	19.62	10.65	1.56	18.16	10.07	1.76	16.67	9.49	1.99	15.15	8.90	2.25		
	67 (19.4)	20.38	14.65	1.20	19.11	14.03	1.37	17.80	13.41	1.55	16.47	12.79	1.75	15.10	12.15	1.98	13.71	11.50	2.24		
	63 (17.2)††	18.88	14.06	1.19	17.70	13.45	1.36	16.49	12.84	1.54	15.24	12.21	1.75	13.97	11.58	1.98	12.67	10.94	2.23		
	62 (16.7)	18.56	17.37	1.19	17.43	16.67	1.36	16.27	16.27	1.54	15.23	15.23	1.75	14.16	14.16	1.98	13.06	13.06	2.23		
	57 (13.9)	18.19	18.19	1.19	17.23	17.23	1.36	16.24	16.24	1.54	15.21	15.21	1.75	14.14	14.14	1.98	13.04	13.04	2.23		
675	72 (22.2)	22.80	12.34	1.22	21.36	11.75	1.39	19.88	11.16	1.57	18.39	10.57	1.78	16.86	9.97	2.01	15.30	9.37	2.27		
	67 (19.4)	20.71	15.51	1.21	19.40	14.88	1.38	18.06	14.23	1.56	16.69	13.58	1.76	15.29	12.92	2.00	13.87	12.24	2.25		
	63 (17.2)††	19.20	14.86	1.21	17.98	14.23	1.37	16.74	13.60	1.56	15.46	12.95	1.76	14.15	12.29	1.99	12.83	11.62	2.25		
	62 (16.7)	18.96	18.41	1.21	17.86	17.86	1.37	16.80	16.80	1.56	15.72	15.72	1.76	14.60	14.60	1.99	13.44	13.44	2.25		
	57 (13.9)	18.84	18.84	1.21	17.83	17.83	1.37	16.78	16.78	1.56	15.70	15.70	1.76	14.58	14.58	1.99	13.42	13.42	2.25		
25HCE424-30 Outdoor Section With FB4CNP030L Indoor Section																					
700	72 (22.2)	27.88	14.26	1.36	25.95	13.50	1.61	24.01	12.73	1.91	22.05	11.96	2.25	20.07	11.19	2.66	18.05	10.40	3.12		
	67 (19.4)	25.38	17.64	1.37	23.61	16.80	1.62	21.83	15.96	1.91	20.05	15.11	2.26	18.22	14.25	2.66	16.40	13.38	3.12		
	63 (17.2)††	23.55	16.97	1.37	21.91	16.14	1.62	20.26	15.30	1.92	18.58	14.46	2.26	16.90	13.62	2.66	15.50	10.97	3.05		
	62 (16.7)	23.71	18.90	1.39	21.59	19.96	1.62	20.00	18.99	1.92	18.55	17.64	2.26	16.97	16.97	2.66	15.48	15.48	3.13		
	57 (13.9)	22.57	22.57	1.38	21.19	21.19	1.63	19.80	19.80	1.92	18.39	18.39	2.26	16.94	16.94	2.66	15.46	15.46	3.13		
800	72 (22.2)	28.38	14.99	1.38	26.39	14.20	1.63	24.38	13.41	1.92	22.36	12.61	2.27	20.33	11.82	2.67	18.26	11.02	3.14		
	67 (19.4)	25.85	18.82	1.38	24.03	17.94	1.64	22.20	17.06	1.93	20.35	16.17	2.28	18.49	15.28	2.68	16.61	14.36	3.14		
	63 (17.2)††	24.02	18.06	1.39	22.32	17.20	1.64	20.62	16.33	1.94	18.90	15.45	2.28	17.16	14.57	2.68	15.41	13.66	3.15		
	62 (16.7)	23.75	22.40	1.39	22.17	21.26	1.64	20.60	20.60	1.93	19.10	19.10	2.28	17.57	17.57	2.68	16.00	16.00	3.15		
	57 (13.9)	23.50	23.50	1.39	22.04	22.04	1.64	20.57	20.57	1.93	19.07	19.07	2.28	17.55	17.55	2.68	15.98	15.98	3.15		
900	72 (22.2)	28.76	15.68	1.39	26.71	14.88	1.64	24.66	14.06	1.94	22.59	13.25	2.29	20.51	12.43	2.69	18.41	11.61	3.16		
	67 (19.4)	26.21	19.94	1.40	24.35	19.02	1.65	22.47	18.11	1.95	20.59	17.18	2.29	18.69	16.24	2.70	16.79	15.27	3.16		
	63 (17.2)††	24.38	19.10	1.40	22.64	18.20	1.66	20.89	17.30	1.95	19.14	16.39	2.30	17.37	15.45	2.70	15.59	14.49	3.17		
	62 (16.7)	24.53	22.87	1.40	23.10	20.91	1.66	21.23	21.23	1.95	19.66	19.66	2.30	18.06	18.06	2.70	16.43	16.43	3.17		
	57 (13.9)	24.27	24.27	1.40	22.74	22.74	1.66	21.20	21.20	1.95	19.63	19.63	2.30	18.04	18.04	2.70	16.41	16.41	3.17		
25HCE430-30 Outdoor Section With FB4CNP030L Indoor Section																					
875	72 (22.2)	34.32	17.82	1.83	32.63	17.00	2.11	30.87	16.16	2.45	29.00	15.31	2.83	27.02	14.44	3.29	24.90	13.54	3.82		
	67 (19.4)	31.12	21.91	1.83	29.57	21.02	2.11	27.96	20.13	2.45	26.25	19.22	2.83	24.44	18.28	3.29	22.51	17.31	3.82		
	63 (17.2)††	28.80	21.05	1.83	27.36	20.17	2.12	25.86	19.29	2.45	24.27	18.39	2.83	22.59	17.46	3.29	20.79	16.50	3.82		
	62 (16.7)	28.27	25.88	1.83	26.88	24.90	2.12	25.44	23.90	2.45	23.95	22.83	2.83	22.44	22.44	3.29	20.97	20.97	3.82		
	57 (13.9)	27.33	27.33	1.83	26.19	26.19	2.12	25.01	25.01	2.45	23.76	23.76	2.83	22.41	22.41	3.28	20.95	20.95	3.82		
1050	72 (22.2)	35.21	19.02	1.86	33.42	18.16	2.15	31.57	17.30	2.49	29.61	16.42	2.88	27.53	15.51	3.33	25.31	14.58	3.87		
	67 (19.4)	31.94	23.85	1.87	30.30	22.92	2.15	28.60	21.97	2.49	26.81	21.01	2.88	24.92	20.01	3.33	22.91	18.98	3.86		
	63 (17.2)††	29.58	22.85	1.87	28.06	21.93	2.15	26.47	21.00	2.49	24.81	20.04	2.88	23.05	19.06	3.33	21.19	18.04	3.87		
	62 (16.7)	29.18	28.33	1.87	27.76	27.51	2.15	26.36	26.36	2.49	24.99	24.99	2.87	23.53	23.53	3.33	21.94	21.94	3.86		
	57 (13.9)	28.84	28.84	1.87	27.62	27.62	2.15	26.33	26.33	2.49	24.96	24.96	2.87	23.50	23.50	3.33	21.91	21.91	3.87		
1125	72 (22.2)	35.51	19.52	1.88	33.70	18.65	2.17	31.81	17.78	2.50	29.81	16.88	2.89	27.70	15.96	3.35	25.45	15.02	3.89		
	67 (19.4)	32.22	24.66	1.88	30.55	23.70	2.17	28.82	22.74	2.50	27.00	21.75	2.89	25.08	20.73	3.35	23.05	19.66	3.88		
	63 (17.2)††	29.85	23.60	1.88	28.30	22.66	2.17	26.69	21.71	2.51	24.99	20.73	2.89	23.21	19.71	3.35	21.33	18.66	3.88		
	62 (16.7)	29.48	29.48	1.88	28.16	28.16	2.17	26.83	26.83	2.51	25.42	25.42	2.89	23.91	23.91	3.35	22.28	22.28	3.88		
57 (13.9)	29.40	29.40	1.88	28.13	28.13	2.17	26.80	26.80	2.51	25.39	25.39	2.89	23.88	23.88	3.35	22.25	22.25	3.89			

See notes on page 17

Manufacturer reserves the right to change, at any time, specifications and designs without notice and without obligations.

Detailed Cooling Capacities# continued

EVAPORATOR AIR		CONDENSER ENTERING AIR TEMPERATURES °F (°C)																				
		75 (23.9)		85 (29.4)				95 (35)				105 (40.6)				115 (46.1)				125 (51.7)		
		Capacity MBtuh		Total Syst.	Capacity MBtuh		Total Syst.	Capacity MBtuh		Total Syst.	Capacity MBtuh		Total Syst.	Capacity MBtuh		Total Syst.	Capacity MBtuh		Total Syst.			
CFM	EWB °F (°C)	Total	Sens‡	KW**	Total	Sens‡	Total	Sens‡	KW**	Total	Sens‡	Total	Sens‡	KW**	Total	Sens‡	Total	Sens‡	KW**			
		25HCE436-31 Outdoor Section With FB4CNP036L Indoor Section																				
1050	72 (22.2)	40.68	21.14	2.30	38.36	20.17	2.57	36.02	19.20	2.86	33.60	18.21	3.18	31.07	17.19	3.55	28.40	16.15	3.99			
	67 (19.4)	36.54	25.79	2.27	34.46	24.78	2.54	32.38	23.78	2.82	30.23	22.77	3.14	27.97	21.72	3.51	25.58	20.63	3.95			
	63 (17.2)††	33.59	24.68	2.24	31.70	23.70	2.51	29.79	22.73	2.80	27.83	21.74	3.11	25.76	20.71	3.49	23.57	19.64	3.93			
	62 (16.7)	32.94	30.29	2.24	31.13	29.22	2.51	29.31	28.12	2.79	27.47	26.98	3.11	25.82	24.96	3.49	24.03	23.08	3.94			
	57 (13.9)	31.69	31.69	2.23	30.22	30.22	2.50	28.74	28.74	2.79	27.19	27.19	3.11	25.53	25.53	3.49	23.74	23.74	3.94			
1200	72 (22.2)	41.59	22.19	2.36	39.16	21.19	2.63	36.70	20.18	2.91	34.18	19.17	3.23	31.53	18.12	3.60	28.77	17.05	4.04			
	67 (19.4)	37.36	27.46	2.32	35.18	26.41	2.59	33.00	25.37	2.87	30.75	24.32	3.19	28.40	23.22	3.56	25.93	22.07	4.00			
	63 (17.2)††	34.35	26.23	2.29	32.37	25.21	2.56	30.36	24.19	2.84	28.32	23.16	3.16	26.17	22.09	3.53	23.91	20.96	3.98			
	62 (16.7)	33.78	32.40	2.29	31.91	31.20	2.56	30.21	29.45	2.84	28.56	27.48	3.17	26.81	25.29	3.54	24.57	24.57	3.99			
	57 (13.9)	33.03	33.03	2.28	31.46	31.46	2.55	29.87	29.87	2.84	28.21	28.21	3.16	26.44	26.44	3.54	24.54	24.54	3.99			
1350	72 (22.2)	42.31	23.19	2.40	39.77	22.15	2.67	37.22	21.12	2.96	34.61	20.08	3.28	31.87	19.00	3.65	29.03	17.91	4.09			
	67 (19.4)	37.99	29.05	2.36	35.73	27.96	2.63	33.47	26.88	2.92	31.15	25.77	3.24	28.72	24.62	3.61	26.19	23.41	4.05			
	63 (17.2)††	34.94	27.70	2.34	32.87	26.63	2.61	30.80	25.58	2.89	28.69	24.49	3.21	26.47	23.37	3.58	24.16	22.17	4.03			
	62 (16.7)	34.52	34.22	2.34	32.84	32.10	2.61	30.87	30.87	2.89	29.10	29.10	3.21	27.23	27.23	3.59	25.22	25.22	4.04			
	57 (13.9)	34.18	34.18	2.33	32.52	32.52	2.60	30.83	30.83	2.89	29.07	29.07	3.21	27.20	27.20	3.59	25.20	25.20	4.04			
25HCE436-L30 Outdoor Section With FB4CNP036L Indoor Section																						
1050	72 (22.2)	39.92	21.53	2.35	37.87	20.72	2.59	35.6	19.83	2.85	33.14	18.88	3.14	30.5	17.87	3.47	27.74	16.84	3.87			
	67 (19.4)	36.37	26.58	2.31	34.54	25.77	2.56	32.51	24.89	2.82	30.29	23.94	3.11	27.91	22.93	3.45	25.42	21.88	3.85			
	63 (17.2)††	33.75	25.57	2.28	32.08	24.78	2.54	30.22	23.92	2.8	28.19	22.98	3.1	26	21.98	3.43	23.71	20.93	3.84			
	62 (16.7)	33.15	31.42	2.28	31.56	30.58	2.53	29.78	29.63	2.8	27.87	28.53	3.09	25.93	25.93	3.43	24.03	24.03	3.84			
	57 (13.9)	31.95	31.95	2.27	30.69	30.69	2.53	29.25	29.25	2.8	27.66	27.66	3.09	25.9	25.9	3.43	24	24	3.84			
1200	72 (22.2)	40.64	22.55	2.4	38.48	21.72	2.65	36.11	20.81	2.9	33.55	19.84	3.19	30.81	18.82	3.52	27.97	17.78	3.91			
	67 (19.4)	37.05	28.24	2.36	35.13	27.42	2.61	33	26.51	2.87	30.69	25.53	3.16	28.23	24.48	3.49	25.66	23.38	3.89			
	63 (17.2)††	34.42	27.14	2.33	32.67	26.32	2.59	30.71	25.42	2.85	28.59	24.45	3.14	26.33	23.41	3.48	23.96	22.31	3.88			
	62 (16.7)	33.89	33.54	2.33	32.24	32.6	2.58	30.47	31.31	2.85	28.6	28.6	3.14	26.72	26.72	3.48	24.69	24.69	3.89			
	57 (13.9)	33.2	33.2	2.32	31.84	31.84	2.58	30.29	30.29	2.85	28.57	28.57	3.14	26.69	26.69	3.48	24.67	24.67	3.89			
1350	72 (22.2)	41.17	23.51	2.45	38.93	22.66	2.7	36.48	21.74	2.95	33.84	20.76	3.23	31.03	19.73	3.56	28.11	18.67	3.96			
	67 (19.4)	37.56	29.84	2.41	35.56	28.98	2.66	33.36	28.05	2.92	30.99	27.03	3.2	28.46	25.94	3.54	25.84	24.76	3.94			
	63 (17.2)††	34.92	28.6	2.38	33.1	27.77	2.63	31.07	26.84	2.9	28.89	25.83	3.19	26.57	24.74	3.52	24.15	23.56	3.93			
	62 (16.7)	34.53	35.37	2.38	32.86	32.86	2.63	31.17	31.17	2.9	29.35	29.35	3.19	27.35	27.35	3.53	25.22	25.22	3.93			
	57 (13.9)	34.24	34.24	2.38	32.79	32.79	2.63	31.14	31.14	2.9	29.32	29.32	3.19	27.33	27.33	3.53	25.2	25.2	3.93			
25HCE436-51, 61 Outdoor Section With FB4CNP036L Indoor Section																						
1050	72 (22.2)	39.66	19.74	2.31	37.83	19.07	2.57	35.94	18.39	2.85	33.94	17.67	3.16	31.84	16.93	3.49	29.62	16.16	3.84			
	67 (19.4)	35.85	24.26	2.28	34.17	23.58	2.54	32.42	22.88	2.82	30.58	22.15	3.12	28.65	21.39	3.46	26.64	20.61	3.81			
	63 (17.2)††	33.11	23.27	2.27	31.53	22.59	2.53	29.89	21.88	2.80	28.15	21.14	3.11	26.35	20.38	3.44	24.46	19.58	3.80			
	62 (16.7)	32.50	28.60	2.27	31.00	27.88	2.52	30.50	24.41	2.82	27.81	26.23	3.10	26.19	26.19	3.43	24.68	24.68	3.80			
	57 (13.9)	31.37	31.37	2.26	30.16	30.16	2.52	28.89	28.89	2.80	27.56	27.56	3.10	26.14	26.14	3.43	24.65	24.65	3.80			
1200	72 (22.2)	40.44	20.71	2.36	38.54	20.03	2.62	36.56	19.32	2.90	34.49	18.60	3.21	32.30	17.84	3.54	30.01	17.05	3.89			
	67 (19.4)	36.57	25.81	2.33	34.82	25.10	2.59	33.00	24.40	2.87	31.10	23.65	3.17	29.10	22.87	3.50	27.02	22.05	3.86			
	63 (17.2)††	33.79	24.71	2.32	32.16	24.02	2.57	30.43	23.29	2.85	28.65	22.53	3.15	26.77	21.74	3.48	24.83	20.91	3.84			
	62 (16.7)	33.27	30.56	2.31	31.74	29.74	2.57	30.10	30.10	2.85	28.63	28.63	3.15	27.13	27.13	3.48	25.54	25.54	3.85			
	57 (13.9)	32.63	32.63	2.31	31.36	31.36	2.57	30.01	30.01	2.85	28.59	28.59	3.15	27.09	27.09	3.48	25.51	25.51	3.85			
1350	72 (22.2)	41.05	21.62	2.40	39.08	20.92	2.67	37.03	20.21	2.95	34.89	19.47	3.26	32.64	18.70	3.58	30.29	17.91	3.93			
	67 (19.4)	37.13	27.29	2.38	35.32	26.58	2.64	33.44	25.84	2.92	31.48	25.07	3.22	29.43	24.25	3.55	27.31	23.39	3.90			
	63 (17.2)††	34.33	26.09	2.36	32.62	25.37	2.62	30.86	24.62	2.89	28.85	23.76	3.18	27.10	23.00	3.53	25.12	22.13	3.88			
	62 (16.7)	34.11	31.77	2.36	32.43	32.43	2.62	30.99	30.99	2.90	29.49	29.49	3.20	27.91	27.91	3.53	26.25	26.25	3.89			
	57 (13.9)	33.70	33.70	2.36	32.36	32.36	2.62	30.95	30.95	2.90	29.46	29.46	3.20	27.88	27.88	3.53	26.22	26.22	3.89			

See notes on page 17

Manufacturer reserves the right to change, at any time, specifications and designs without notice and without obligations.

Detailed Cooling Capacities# continued

EVAPORATOR AIR		CONDENSER ENTERING AIR TEMPERATURES °F (°C)																					
		75 (23.9)		85 (29.4)				95 (35)				105 (40.6)				115 (46.1)				125 (51.7)			
		CFM	EWB °F (°C)	Capacity MBtuh		Total Syst. KW**	Capacity MBtuh		Total Syst. KW**	Capacity MBtuh		Total Syst. KW**	Capacity MBtuh		Total Syst. KW**	Capacity MBtuh		Total Syst. KW**	Capacity MBtuh		Total Syst. KW**		
Total	Sens‡			Total	Sens‡		Total	Sens‡		Total	Sens‡		Total	Sens‡		Total	Sens‡		Total	Sens‡			
25HCE442-30 Outdoor Section With FB4CNP042L Indoor Section																							
1225	72 (22.2)	51.32	26.41	2.69	47.64	24.87	3.06	43.91	23.32	3.47	40.04	21.72	3.95	35.98	20.06	4.53	31.71	18.34	5.24				
	67 (19.4)	46.76	32.42	2.71	43.39	30.71	3.08	40.00	29.00	3.48	36.47	27.23	3.95	32.76	25.39	4.53	28.86	23.47	5.26				
	63 (17.2)††	43.44	31.24	2.73	40.29	29.56	3.09	37.15	27.88	3.48	33.87	26.14	3.95	30.42	24.33	4.54	26.78	22.44	5.27				
	62 (16.7)	42.63	38.26	2.73	39.57	36.35	3.09	36.51	34.43	3.48	33.36	32.42	3.95	30.05	30.05	4.53	26.91	26.91	5.27				
1400	57 (13.9)	40.97	40.97	2.74	38.33	38.33	3.09	35.68	35.68	3.48	32.92	32.92	3.95	29.99	29.99	4.53	26.87	26.87	5.27				
	72 (22.2)	52.31	27.67	2.71	48.51	26.09	3.09	44.64	24.49	3.51	40.66	22.84	3.99	36.46	21.13	4.56	32.09	19.36	5.28				
	67 (19.4)	47.68	34.47	2.74	44.22	32.69	3.11	40.70	30.90	3.51	37.05	29.05	3.99	33.23	27.13	4.57	29.23	25.13	5.29				
	63 (17.2)††	44.34	33.15	2.76	41.10	31.40	3.12	37.83	29.64	3.52	34.45	27.84	3.99	30.89	25.94	4.57	27.16	23.97	5.31				
1575	62 (16.7)	43.61	40.95	2.76	40.48	38.90	3.12	37.36	36.78	3.52	34.21	34.21	3.99	31.10	31.10	4.57	27.81	27.81	5.30				
	57 (13.9)	42.67	42.67	2.77	39.89	39.89	3.12	37.09	37.09	3.52	34.16	34.16	3.99	31.06	31.06	4.57	27.78	27.78	5.30				
	72 (22.2)	53.05	28.87	2.74	49.15	27.24	3.13	45.20	25.59	3.54	41.11	23.89	4.02	36.82	22.15	4.60	32.36	20.33	5.31				
	67 (19.4)	48.40	36.42	2.77	44.82	34.56	3.14	41.22	32.70	3.55	37.49	30.78	4.03	33.59	28.77	4.61	29.52	26.67	5.33				
1225	63 (17.2)††	45.03	34.96	2.79	41.70	33.15	3.15	38.36	31.32	3.55	34.88	29.43	4.03	31.25	27.46	4.61	27.45	25.38	5.34				
	62 (16.7)	44.48	43.33	2.79	41.27	41.27	3.15	38.30	38.30	3.55	35.22	35.22	4.02	31.98	31.98	4.61	28.55	28.55	5.34				
	57 (13.9)	44.09	44.09	2.79	41.18	41.18	3.15	38.25	38.25	3.55	35.18	35.18	4.02	31.95	31.95	4.61	28.52	28.52	5.34				
	25HCE442L-30 Outdoor Section With FB4CNP042L Indoor Section																						
1225	72 (22.2)	48.32	25.52	2.80	45.97	24.62	3.14	43.50	23.67	3.49	40.85	22.67	3.89	38.04	21.61	4.35	35.05	20.52	4.89				
	67 (19.4)	44.42	31.59	2.81	42.27	30.66	3.13	40.00	29.70	3.48	37.57	28.68	3.87	34.98	27.61	4.33	32.22	26.48	4.89				
	63 (17.2)††	41.49	30.54	2.81	39.49	29.61	3.13	37.38	28.65	3.47	35.12	27.63	3.86	32.69	26.54	4.33	30.11	25.39	4.89				
	62 (16.7)	40.75	37.42	2.81	38.82	36.45	3.12	36.78	35.43	3.46	34.64	34.29	3.85	32.59	32.26	4.32	30.26	30.26	4.89				
	57 (13.9)	39.25	39.25	2.81	37.71	37.71	3.12	36.06	36.06	3.46	34.28	34.28	3.85	32.34	32.34	4.32	30.22	30.22	4.89				
1400	72 (22.2)	49.10	26.71	2.84	46.65	25.79	3.18	44.08	24.83	3.53	41.35	23.82	3.93	38.44	22.75	4.38	35.37	21.65	4.92				
	67 (19.4)	45.20	33.55	2.84	42.96	32.61	3.17	40.60	31.63	3.52	38.08	30.59	3.91	35.40	29.49	4.37	32.58	28.32	4.93				
	63 (17.2)††	42.29	32.38	2.85	40.20	31.44	3.17	37.99	30.45	3.51	35.66	29.40	3.90	33.14	28.29	4.36	30.48	27.10	4.93				
	62 (16.7)	41.64	40.02	2.85	39.64	38.96	3.16	38.03	36.15	3.50	35.73	35.37	3.90	33.44	33.44	4.37	31.19	31.19	4.93				
1575	57 (13.9)	40.81	40.81	2.85	39.15	39.15	3.16	37.38	37.38	3.50	35.47	35.47	3.89	33.40	33.40	4.36	31.16	31.16	4.93				
	72 (22.2)	49.67	27.84	2.87	47.15	26.91	3.22	44.51	25.93	3.57	41.70	24.91	3.97	38.72	23.84	4.42	35.58	22.72	4.96				
	67 (19.4)	45.78	35.42	2.88	43.46	34.46	3.21	41.03	33.46	3.56	38.40	32.37	3.95	35.71	31.25	4.41	32.83	30.04	4.96				
	63 (17.2)††	42.89	34.12	2.88	40.72	33.16	3.20	38.45	32.15	3.55	36.05	31.08	3.94	33.48	29.92	4.40	30.78	28.68	4.97				
1575	62 (16.7)	42.39	42.30	2.88	40.61	40.23	3.20	38.75	38.22	3.55	36.48	36.48	3.94	34.29	34.29	4.41	31.93	31.93	4.96				
	57 (13.9)	42.08	42.08	2.88	40.32	40.32	3.20	38.45	38.45	3.54	36.44	36.44	3.94	34.25	34.25	4.41	31.90	31.90	4.96				

Manufacturer reserves the right to change, at any time, specifications and designs without notice and without obligations.

Detailed Cooling Capacities# continued

EVAPORATOR AIR		CONDENSER ENTERING AIR TEMPERATURES °F (°C)																				
		75 (23.9)		85 (29.4)				95 (35)				105 (40.6)				115 (46.1)				125 (51.7)		
		Capacity MBtuh		Total Syst. KW**	Capacity MBtuh		Total Syst. KW**	Capacity MBtuh		Total Syst. KW**	Capacity MBtuh		Total Syst. KW**	Capacity MBtuh		Total Syst. KW**	Capacity MBtuh		Total Syst. KW**			
Total	Sens‡	Total	Sens‡		Total	Sens‡		Total	Sens‡		Total	Sens‡		Total	Sens‡		Total	Sens‡		Total	Sens‡	
25HCE448-30, 50, 60 Outdoor Section With FB4CNP048L Indoor Section																						
1400	72 (22.2)	56.85	29.73	3.01	53.80	28.52	3.49	50.55	27.25	4.03	46.99	25.86	4.63	43.14	24.39	5.33	38.94	22.80	6.14			
	67 (19.4)	51.69	36.52	3.00	48.93	35.26	3.48	46.00	33.93	4.00	42.80	32.52	4.60	39.31	30.98	5.30	35.51	29.32	6.12			
	63 (17.2)††	47.92	35.13	2.99	45.36	33.89	3.46	42.67	32.59	3.98	39.72	31.19	4.57	36.51	29.68	5.27	32.99	28.03	6.10			
	62 (16.7)	47.01	43.08	2.99	44.55	41.74	3.46	41.94	40.30	3.97	39.15	38.71	4.57	36.14	36.14	5.27	33.20	33.20	6.10			
	57 (13.9)	45.21	45.21	2.99	43.19	43.19	3.45	41.05	41.05	3.97	38.69	38.69	4.57	36.07	36.07	5.27	33.16	33.16	6.10			
1600	72 (22.2)	57.93	31.13	3.06	54.75	29.89	3.55	51.35	28.58	4.08	47.67	27.17	4.69	43.67	25.65	5.39	39.35	24.03	6.20			
	67 (19.4)	52.70	38.79	3.05	49.84	37.50	3.53	46.77	36.12	4.06	43.44	34.65	4.66	39.83	33.06	5.36	35.91	31.33	6.18			
	63 (17.2)††	48.90	37.25	3.04	46.25	35.98	3.51	43.42	34.62	4.03	40.37	33.18	4.63	37.04	31.61	5.33	33.41	29.89	6.16			
	62 (16.7)	48.09	46.04	3.04	45.55	44.58	3.51	42.90	42.95	4.03	40.14	40.14	4.63	37.35	37.35	5.34	34.25	34.25	6.17			
	57 (13.9)	47.05	47.05	3.04	44.90	44.90	3.51	42.61	42.61	4.03	40.09	40.09	4.63	37.30	37.30	5.34	34.22	34.22	6.17			
1800	72 (22.2)	58.79	32.49	3.10	55.49	31.21	3.60	52.00	29.88	4.13	48.19	28.44	4.74	44.08	26.89	5.44	39.65	25.25	6.26			
	67 (19.4)	53.52	41.02	3.10	50.54	39.67	3.58	47.37	38.24	4.11	43.95	36.73	4.72	40.23	35.06	5.42	36.23	33.24	6.24			
	63 (17.2)††	49.69	39.32	3.09	46.93	38.00	3.56	44.02	36.59	4.09	40.87	35.10	4.69	37.45	33.46	5.39	33.74	31.64	6.22			
	62 (16.7)	49.05	48.68	3.09	46.45	46.45	3.56	43.96	43.96	4.09	41.29	41.29	4.69	38.36	38.36	5.40	35.09	35.09	6.23			
	57 (13.9)	48.59	48.59	3.09	46.33	46.33	3.56	43.91	43.91	4.09	41.25	41.25	4.69	38.32	38.32	5.40	35.06	35.06	6.23			
25HCE460-30, 50, 60 Outdoor Section With FX4DN(B,F)061L Indoor Section																						
1750	72 (22.2)	69.71	36.22	3.67	66.16	34.89	4.27	62.51	33.53	4.99	58.68	32.11	5.83	54.60	30.60	6.84	50.26	29.01	8.03			
	67 (19.4)	63.53	44.80	3.64	60.33	43.43	4.24	57.00	42.02	4.96	53.50	40.54	5.80	49.79	38.98	6.80	45.77	37.30	7.99			
	63 (17.2)††	59.03	43.14	3.62	56.06	41.79	4.22	52.97	40.38	4.93	49.73	38.91	5.78	46.26	37.35	6.78	42.53	35.68	7.96			
	62 (16.7)	57.95	53.13	3.62	55.06	51.68	4.22	52.11	50.15	4.93	49.00	48.47	5.77	45.84	45.84	6.77	42.75	42.75	7.96			
	57 (13.9)	56.08	56.08	3.61	53.71	53.71	4.22	51.24	51.24	4.92	48.62	48.62	5.77	45.78	45.78	6.77	42.69	42.69	7.96			
2000	72 (22.2)	70.94	37.98	3.74	67.26	36.62	4.35	63.47	35.23	5.06	59.50	33.78	5.91	55.29	32.23	6.92	50.82	30.62	8.11			
	67 (19.4)	64.73	47.70	3.71	61.36	46.27	4.32	57.91	44.83	5.03	54.29	43.30	5.88	50.43	41.67	6.89	46.33	39.96	8.08			
	63 (17.2)††	60.18	45.83	3.69	57.08	44.43	4.30	53.88	42.99	5.01	50.51	41.48	5.86	46.93	39.86	6.86	43.09	38.13	8.05			
	62 (16.7)	59.24	56.92	3.69	56.27	55.28	4.29	53.28	53.28	5.01	50.44	50.44	5.86	47.43	47.43	6.86	44.15	44.15	8.06			
	57 (13.9)	58.35	58.35	3.68	55.83	55.83	4.29	53.18	53.18	5.01	50.38	50.38	5.86	47.36	47.36	6.86	44.10	44.10	8.06			
2250	72 (22.2)	71.87	39.65	3.81	68.08	38.26	4.42	64.17	36.84	5.14	60.10	35.37	5.99	55.78	33.79	7.00	51.19	32.15	8.20			
	67 (19.4)	65.60	50.45	3.78	62.14	48.99	4.39	58.58	47.50	5.11	54.86	45.93	5.96	50.94	44.26	6.97	46.73	42.44	8.16			
	63 (17.2)††	61.04	48.39	3.76	57.85	46.95	4.37	54.53	45.45	5.09	51.08	43.89	5.94	47.42	42.22	6.95	43.49	40.40	8.14			
	62 (16.7)	60.36	60.36	3.76	57.65	57.65	4.37	54.85	54.85	5.09	51.89	51.89	5.94	48.73	48.73	6.96	45.28	45.28	8.15			
	57 (13.9)	60.24	60.24	3.76	57.57	57.57	4.37	54.78	54.78	5.09	51.83	51.83	5.94	48.66	48.66	6.95	45.23	45.23	8.15			

#Detailed cooling capacities are based on indoor and outdoor unit at the same elevation per AHRI standard 210/240-2008. If additional tubing length and/or indoor unit is located above outdoor unit, a slight variation in capacity may occur.
 ‡Sensible capacities shown are based on 80°F (27°C) entering air at the indoor coil. For sensible capacities at other than 80°F (27°C), deduct 835 Btuh (245 kW) per 1000 CFM (480 L/S) of indoor coil air for each degree below 80°F (27°C), or add 835 Btuh (245 kW) per 1000 CFM (480 L/S) of indoor coil air per degree above 80°F (27°C).

**Total System, kw is total of indoor and outdoor unit kilowatts.

††At TVA rating indoor condition (75°F edb/63°F ewb). All other indoor air temperatures are at 80°F edb.

NOTE: When the required data falls between the published data, interpolation may be performed. Extrapolation is not an acceptable practice.

EWB — Entering Wet Bulb1

Manufacturer reserves the right to change, at any time, specifications and designs without notice and without obligations.

Heat Pump Heating Performance continued

INDOOR AIR		OUTDOOR COIL ENTERING AIR TEMPERATURES °F (°C)																							
		-3 (19.4)			7 (-13.9)			17 (-8.3)			27 (-2.18)			37 (2.8)			47 (8.3)			57 (13.9)			67 (19.4)		
		EDB	CFM	Capacity MBtuh		Total Syst. KW†	Capacity MBtuh		Total Syst. KW†	Capacity MBtuh		Total Syst. KW†	Capacity MBtuh		Total Syst. KW†	Capacity MBtuh		Total Syst. KW†	Capacity MBtuh		Total Syst. KW†	Capacity MBtuh		Total Syst. KW†	
Total	Integ*			Total	Integ*		Total	Integ*		Total	Integ*		Total	Integ*		Total	Integ*		Total	Integ*		Total	Integ*		Total
25HCE442-30 Outdoor Section With FB4CNP042L Indoor Section																									
65 (18.3)	1225	16.83	15.48	2.68	21.19	19.47	2.76	26.01	23.72	2.85	31.22	27.73	2.96	36.23	32.97	3.06	41.58	41.58	3.18	47.26	47.26	3.29	51.99	51.99	3.36
	1400	17.17	15.80	2.70	21.57	19.82	2.76	26.98	24.60	2.86	31.57	28.03	2.94	36.63	33.33	3.03	42.10	42.10	3.14	47.44	47.44	3.20	51.82	51.82	3.26
	1575	17.47	16.07	2.72	21.88	20.11	2.77	27.28	24.88	2.86	31.89	28.33	2.93	36.97	33.64	3.01	42.45	42.45	3.10	47.42	47.42	3.15	51.55	51.55	3.20
70 (21.1)	1225	15.95	14.68	2.79	20.41	18.76	2.86	25.20	22.98	2.95	30.75	27.31	3.08	35.75	32.53	3.19	41.00	41.00	3.32	46.67	46.67	3.43	51.41	51.41	3.51
	1400	16.27	14.97	2.80	20.76	19.08	2.87	25.60	23.34	2.95	31.08	27.61	3.06	36.11	32.86	3.15	41.49	41.49	3.27	46.95	46.95	3.35	51.31	51.31	3.40
	1575	16.54	15.22	2.82	21.07	19.36	2.88	25.96	23.67	2.95	31.38	27.87	3.05	36.45	33.17	3.14	41.91	41.91	3.24	47.00	47.00	3.29	51.07	51.07	3.34
75 (23.9)	1225	15.11	13.90	2.89	19.67	18.08	2.98	24.49	22.33	3.07	30.28	26.90	3.21	35.25	32.07	3.33	40.41	40.41	3.47	46.09	46.09	3.58	50.81	50.81	3.67
	1400	15.40	14.17	2.91	20.00	18.37	2.98	24.87	22.67	3.06	30.62	27.20	3.19	35.63	32.42	3.29	40.89	40.89	3.41	46.39	46.39	3.50	50.77	50.77	3.56
	1575	15.65	14.40	2.93	20.28	18.64	2.99	25.19	22.97	3.07	30.90	27.44	3.17	35.95	32.71	3.27	41.30	41.30	3.38	46.51	46.51	3.44	50.58	50.58	3.49
25HCE442-L30 Outdoor Section With FB4CNP042L Indoor Section																									
65 (18.3)	1225	16.15	14.86	2.54	20.31	18.67	2.64	25.22	23.00	2.76	30.64	27.21	2.90	35.95	32.71	3.04	40.44	40.44	3.13	44.41	44.41	3.23	47.39	47.39	3.31
	1400	16.46	15.14	2.56	20.66	18.98	2.65	25.87	23.59	2.76	31.04	27.57	2.88	36.20	32.94	3.00	40.37	40.37	3.07	44.11	44.11	3.15	47.26	47.26	3.22
	1575	16.72	15.39	2.58	20.96	19.26	2.66	26.48	24.14	2.77	31.39	27.88	2.87	36.48	33.20	2.97	40.23	40.23	3.04	43.70	43.70	3.10	46.51	46.51	3.15
70 (21.1)	1225	15.37	14.14	2.63	19.56	17.98	2.74	24.40	22.25	2.86	30.11	26.75	3.02	35.36	32.18	3.17	40.00	40.00	3.27	43.97	43.97	3.38	47.28	47.28	3.47
	1400	15.67	14.41	2.65	19.91	18.30	2.75	24.81	22.62	2.86	30.49	27.08	3.00	35.82	32.60	3.13	39.99	39.99	3.21	43.75	43.75	3.30	46.90	46.90	3.37
	1575	15.93	14.65	2.67	20.21	18.57	2.76	25.18	22.95	2.86	30.82	27.37	2.99	36.06	32.81	3.10	39.90	39.90	3.17	43.44	43.44	3.24	46.31	46.31	3.30
75 (23.9)	1225	14.54	13.38	2.73	18.78	17.26	2.85	23.63	21.55	2.97	29.57	26.26	3.15	34.76	31.64	3.31	39.55	39.55	3.43	43.46	43.46	3.54	46.75	46.75	3.62
	1400	14.83	13.65	2.74	19.13	17.58	2.85	24.03	21.91	2.97	29.94	26.59	3.12	35.22	32.05	3.27	39.59	39.59	3.36	43.35	43.35	3.45	46.40	46.40	3.52
	1575	15.09	13.88	2.76	19.42	17.85	2.86	24.37	22.22	2.97	30.27	26.88	3.11	35.50	32.31	3.24	39.54	39.54	3.31	43.11	43.11	3.39	46.01	46.01	3.46
25HCE448-30, 50, 60 Outdoor Section With FB4CNP048L Indoor Section																									
65 (18.3)	1400	18.06	16.61	2.84	23.23	21.35	2.95	28.62	26.10	3.07	35.13	31.20	3.23	40.37	36.74	3.36	46.19	46.19	3.52	52.96	52.96	3.69	60.25	60.25	3.85
	1600	18.43	16.96	2.87	23.65	21.73	2.97	29.08	26.52	3.08	35.52	31.54	3.22	40.85	37.18	3.34	46.77	46.77	3.48	53.78	53.78	3.63	60.78	60.78	3.78
	1800	18.77	17.27	2.90	24.02	22.07	3.00	29.49	26.89	3.09	35.88	31.87	3.23	41.25	37.54	3.34	47.27	47.27	3.46	54.35	54.35	3.60	61.14	61.14	3.73
70 (21.1)	1400	17.10	15.73	2.94	22.37	20.56	3.06	27.80	25.35	3.18	34.45	30.60	3.35	39.83	36.24	3.50	45.50	45.50	3.66	52.11	52.11	3.85	59.42	59.42	4.01
	1600	17.45	16.06	2.97	22.77	20.92	3.08	28.25	25.76	3.19	34.96	31.05	3.35	40.26	36.64	3.48	46.07	46.07	3.62	52.88	52.88	3.78	59.97	59.97	3.93
	1800	17.72	16.30	3.00	23.10	21.23	3.10	28.64	26.12	3.21	35.34	31.39	3.35	40.64	36.99	3.47	46.55	46.55	3.60	53.57	53.57	3.75	60.35	60.35	3.88
85 (29.4)	1400	14.48	13.33	3.29	19.88	18.27	3.43	25.43	23.18	3.58	31.19	27.70	3.74	38.27	34.83	3.99	43.48	43.48	4.17	49.52	49.52	4.35	56.66	56.66	4.53
	1600	14.77	13.59	3.32	20.23	18.59	3.45	25.83	23.55	3.59	31.68	28.14	3.73	38.67	35.19	3.95	44.00	44.00	4.11	50.28	50.28	4.28	57.31	57.31	4.44
	1800	15.00	13.80	3.35	20.49	18.83	3.47	26.15	23.84	3.60	32.05	28.47	3.74	39.01	35.50	3.93	44.45	44.45	4.08	50.96	50.96	4.23	57.77	57.77	4.38
25HCE460-30, 50, 60 Outdoor Section With FX4DN(B,F)061L Indoor Section																									
65 (18.3)	1750	21.79	20.04	3.35	27.51	25.28	3.48	33.77	30.79	3.62	41.16	36.55	3.80	47.80	43.50	3.96	55.22	55.22	4.13	63.89	63.89	4.31	72.41	72.41	4.49
	2000	22.17	20.40	3.38	27.93	25.67	3.49	34.27	31.24	3.62	41.55	36.90	3.78	48.32	43.97	3.93	55.88	55.88	4.08	64.55	64.55	4.23	72.64	72.64	4.39
	2250	22.52	20.71	3.42	28.30	26.01	3.52	34.70	31.64	3.64	41.91	37.22	3.79	48.78	44.39	3.92	56.46	56.46	4.07	64.91	64.91	4.19	72.49	72.49	4.33
70 (21.1)	1750	21.01	19.33	3.50	26.77	24.60	3.63	33.00	30.09	3.78	40.68	36.13	3.98	47.23	42.98	4.14	54.50	54.50	4.32	63.05	63.05	4.51	71.52	71.52	4.70
	2000	21.38	19.67	3.53	27.19	24.99	3.65	33.48	30.53	3.78	41.09	36.49	3.96	47.73	43.44	4.11	55.15	55.15	4.27	63.75	63.75	4.42	71.80	71.80	4.59
	2250	21.73	19.99	3.57	27.57	25.33	3.68	33.91	30.92	3.80	41.45	36.82	3.97	48.17	43.84	4.10	55.71	55.71	4.25	64.15	64.15	4.37	71.74	71.74	4.52
75 (23.9)	1750	20.18	18.57	3.66	25.98	23.88	3.80	32.21	29.37	3.95	40.16	35.67	4.17	46.66	42.46	4.34	53.80	53.80	4.52	62.20	62.20	4.72	70.62	70.62	4.91
	2000	20.56	18.91	3.69	26.42	24.28	3.82	32.69	29.81	3.95	40.62	36.07	4.15	47.14	42.89	4.30	54.42	54.42	4.46	62.94	62.94	4.62	70.93	70.93	4.80
	2250	20.90	19.23	3.73	26.79	24.62	3.85	33.11	30.19	3.97	40.99	36.40	4.15	47.57	43.29	4.29	54.97	54.97	4.44	63.39	63.39	4.57	70.94	70.94	4.72

NOTE: When the required data falls between the published data, interpolation may be performed. Extrapolation is not an acceptable practice.

* The Btuh heating capacity values shown are net integrated values from which the defrost effect has been subtracted. The Btuh heating from supplement heaters should be added to those values to obtain total Sys. capacity.

† The kW values include the compressor, outdoor fan motor, and indoor blower motor. The kW from supplement heaters should be added to these values to obtain total Sys. kilowatts.

EDB — Entering Dry Bulb2

Manufacturer reserves the right to change, at any time, specifications and designs without notice and without obligations.

Guide Specifications

General

Air-Cooled, Split-System Heat Pump
25HCE4
1-1/2 to 5 nominal tons

System Description

Outdoor-mounted, air-cooled, split-system heat pump unit suitable for ground or rooftop installation. Unit consists of a hermetic compressor, an air-cooled coil, propeller-type condenser fan, and a control box. Unit will discharge supply air upward as shown on contract drawings. Unit will be used in a refrigeration circuit to match up to a packaged fan coil or coil unit.

Quality Assurance

- Unit will be rated in accordance with the latest edition of AHRI Standard 210/240.
- Unit will be certified for capacity and efficiency, and listed in the latest AHRI directory.
- Unit construction will comply with latest edition of ANSI/ASHRAE and with NEC.
- Unit will be constructed in accordance with UL standards and will carry the UL label of approval. Unit will have C-UL approval.
- Unit cabinet will be capable of withstanding Federal Test Method Standard No. 141 (Method 6061) 500-hr salt spray test.
- Air-cooled condenser coils are pressure tested and the outdoor unit is leak tested.
- Unit constructed in ISO9001 approved facility.

Delivery, Storage, and Handling

Unit will be shipped as single package only and is stored and handled per unit manufacturer's recommendations.

Warranty (for inclusion by specifying engineer)

U.S. and Canada only.

PRODUCTS

Equipment

Factory assembled, single piece, air-cooled heat pump unit. Contained within the unit enclosure is all factory wiring, piping, controls, compressor, refrigerant charge Puron® (R-410A), and special features required prior to field start-up.

Unit Cabinet

Unit cabinet will be constructed of galvanized steel, bonderized, and coated with a powder coat paint.
Available with dense grille only.

Fans

Condenser fan will be direct-drive propeller type, discharging air upward.
Condenser fan motors will be totally enclosed, 1-phase type with class B insulation and permanently lubricated bearings.
Shafts will be corrosion resistant.
Fan blades will be statically and dynamically balanced.
Condenser fan openings will be equipped with steel wire safety guards.

Compressor

Compressor will be hermetically sealed.
Compressor will be mounted on rubber vibration isolators.

Condenser Coil

Condenser coil will be air cooled.
Coil will be constructed of aluminum fins mechanically bonded to copper or aluminum tubes which are then cleaned, dehydrated, and sealed.

Refrigeration Components

Refrigeration circuit components will include liquid-line shutoff valve with sweat connections, vapor-line shutoff valve with sweat connections, system charge of Puron® (R-410A) refrigerant, POE compressor oil, accumulator, and reversing valve.

Operating Characteristics

The capacity of the unit will meet or exceed _____ Btuh at a suction temperature of _____ °F/°C. The power consumption at full load will not exceed _____ kW.

Combination of the unit and the evaporator or fan coil unit will have a total net cooling capacity of _____ Btuh or greater at conditions of _____ CFM entering air temperature at the evaporator at _____ °F wet bulb and _____ °F/°C dry bulb, and air entering the unit at _____ °F/°C.

The system will have a SEER of _____ Btuh/watt or greater at DOE conditions.

Electrical Requirements

Nominal unit electrical characteristics will be _____ v, single phase, 60 hz. The unit will be capable of satisfactory operation within voltage limits of _____ v to _____ v.

Unit electrical power will be single point connection.

Control circuit will be 24v.

Special Features

Refer to section of this literature identifying accessories and descriptions for specific features and available enhancements.

System Design Summary

1. Intended for outdoor installation with free air inlet and outlet. Outdoor fan external static pressure available is less than 0.01-in. wc.
2. Minimum outdoor operating air temperature without low-ambient operation accessory is 55°F (12.8°C).
3. Maximum outdoor operating air temperature for cooling mode is 125°F (51.7°C).
4. Minimum outdoor operating air temperature for heating mode is -10°F (-23.3°C).
5. Maximum outdoor operating air temperature for heating mode is 66°F (18.9°C).
6. For reliable operation, unit should be level in all horizontal planes.
7. For interconnecting refrigerant tube lengths greater than 80 ft (23.4 m) and/or elevation differences between indoor and outdoor units greater than 20 ft (6.1 m), consult Residential Piping and Longline Guideline and Service Manual available from equipment distributor.
8. If any refrigerant tubing is buried, provide a 6 in. (152.4 mm) vertical rise to the valve connections at the unit. Refrigerant tubing lengths up to 36 in. (914.4 mm) may be buried without further consideration. Do not bury refrigerant lines longer than 36 in. (914.4 mm).
9. Use only copper wire for electric connection at unit. Aluminum and clad aluminum are not acceptable for the type of connector provided.
10. Do not apply capillary tube indoor coils to these units.
11. Factory-supplied filter drier must be installed.

