



NS2-0000-xx™

FOR RESIDENTIAL & LIGHT COMMERCIAL HVAC APPLICATIONS

GENERAL DESCRIPTION & OPERATION

The NS2™ Switch has a glass-filled polycarbonate housing containing a sensing diaphragm and an integral snap-acting switch with three male 90° quick-connect terminals. The switch can be actuated by a pressure or vacuum air flow or the differential between two air flows. The field adjustable set point range of the switch is 0.10"w.c. to 10.0"w.c. Using the switch accessories contained in this kit, the NS2™ switch can be applied to a wide variety of residential and light commercial HVAC applications.

SET POINT RANGE & ADJUSTMENT

Calibration requires a manometer (not included in the kit) as well as the included 7/32" hex wrench.

1. Establish the set point as follows. Referring to **Table 2** in this manual, select the appropriate spring for the required set point range. Insert the spring into the center well of the mounting pan (light gray side of the switch housing).
2. Insert the black set point adjustment screw, and rotate it manually until the threads are engaged.
3. Connect the switch to a manometer. Using the 7/32" hex wrench provided in the kit, turn the adjustment screw in small increments until the desired set point is reached. Turn the screw clockwise to increase the set point or counterclockwise to decrease the set point. For precise calibration, confirm the set point at actual operating temperature with a manometer. Following precise calibration, if desired, seal the adjusting screw using Three Bond #TB3015B UV curable adhesive/sealant. **Do not place the switch in operation without knowing what the set point is: doing so could create a hazardous situation.**

MOUNTING

Using the (2) #6-3/8 mounting screws included in the kit, mount via the integral foot bracket (see Fig. 1) **or**, via either of the optional brackets (see Figs 4 & 5) included in the kit. If using one of the optional brackets, attach it to the switch with the self tapping screw provided before mounting the switch. Select a mounting location free from vibration. Mount with the diaphragm in any vertical plane. Avoid mounting with the sample line connections directed upward.

ELECTRICAL CONNECTIONS

The snap switch has three 1/4" 90° male quick connect terminals. Before pressure is applied to the diaphragm, the switch contacts are in the deactivated position as shown in **Figure 2**.

AIR SAMPLING CONNECTION

Integral sample line connectors, located on both sides of the diaphragm, accept 3/16" ID flexible tubing. See Figure 3. The High or Positive inlet (P1) is black and the Low or Negative inlet (P2) is gray. Connect the sample lines as follows:

Positive Pressure Only: Connect the sample line to P1; P2 remains open to the atmosphere.

Negative Pressure Only: Connect the sample line to P2; P1 remains open to the atmosphere.

Two Negative Samples: Connect higher negative sample to P2; lower sample to P1.

Two Positive Samples: Connect higher positive sample to P1; lower sample to P2.

One Positive and One Negative: Connect positive sample to P1; connect negative sample to P2.

USING A FLOW-RESTRICTING ORIFICE

Some applications require a delayed switching action after set point is reached. The

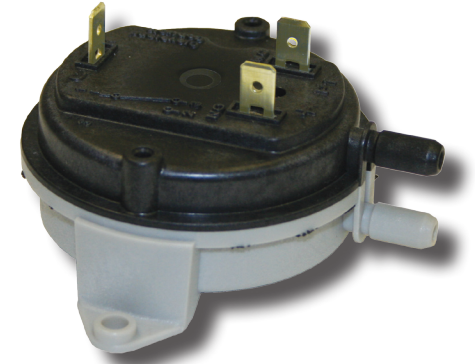

delay is created by inserting an orifice plug into either or both of the sample line connectors to restrict air flow .

Eight orifice plugs in four color-coded sizes are included in the kit, as shown in **Table 3**. Note that the measuring device and the NS2™ air switch must both contain the same size restricting orifice in order to obtain an accurate measurement of the set point. More information is available in **Technical Bulletin 030109-1**.

TABLE 1: MODEL SELECTION

NS2-0000-00	Basic model
NS2-0000-01	Bleed hole in Mounting Pan

TABLE 2: SPRING SELECTION

Part No.	Color	Set Point Range ("wc)
61523	Black	0.10 thru 0.30
61513	Natural	0.30 thru 0.90
61514	Yellow	0.90 thru 2.50
61515	Red	2.50 thru 5.00
61524	Blue	5.00 thru 10.00

TABLE 3: ORIFICE SELECTION

Part No.	Color	Diameter
61518001	Green	0.010
61518002	Gray	0.016
61518003	Red	0.028
61518004	Blue	0.035



Cleveland Controls
DIVISION OF UNICONTROL INC.
1111 Brookpark Rd
Cleveland OH 44109

Tel: 216-398-0330

Fax: 216-398-8558

Email: saleshvac@unicontrolinc.com

Web page: <http://www.clevelandcontrols.com>

Are you reading a FAX or a COPY of this bulletin? DOWNLOAD the full-color PDF version of this and other literature at our website!

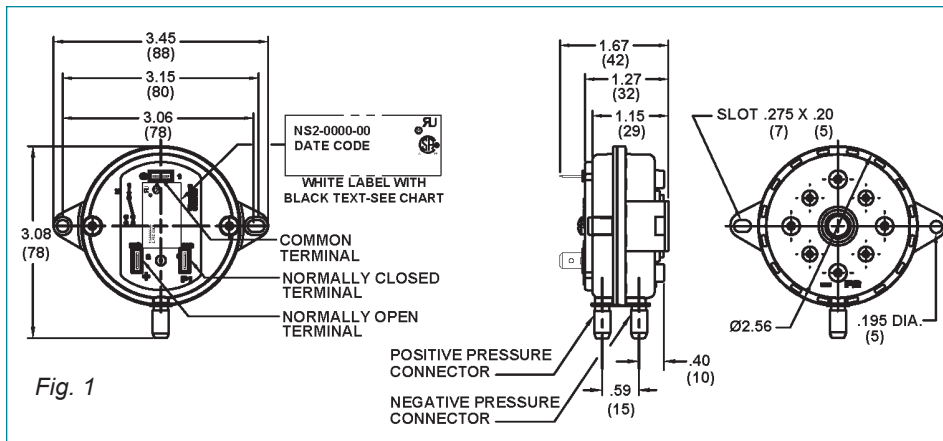

Fig. 1

Fig. 2

Fig. 3

Fig. 1: Dimensions: NS2 Switch with integral connectors and mounting feet.

Fig.2. Without pressure applied to the diaphragm, switch contacts are in the position shown.

Fig. 3. Standard integral connector accepts 3/16" ID tubing.

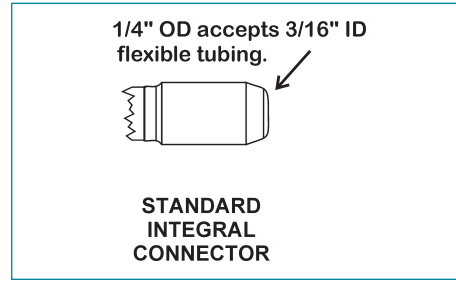
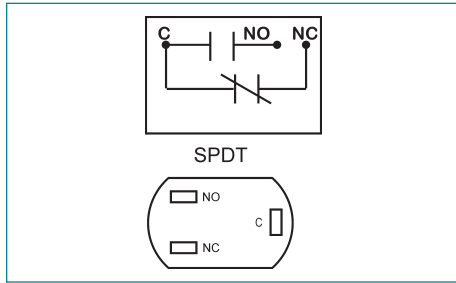

Figure 4: Half Strap Bracket

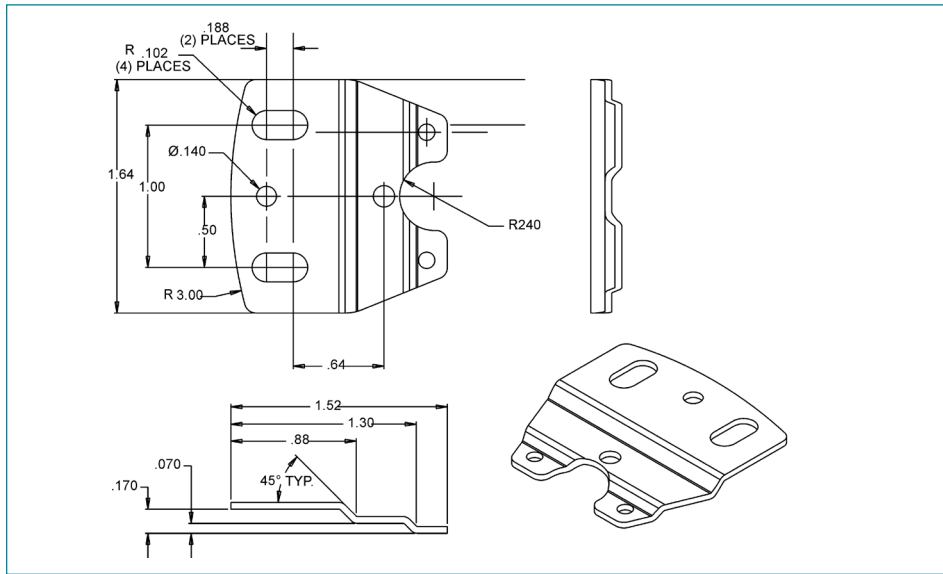
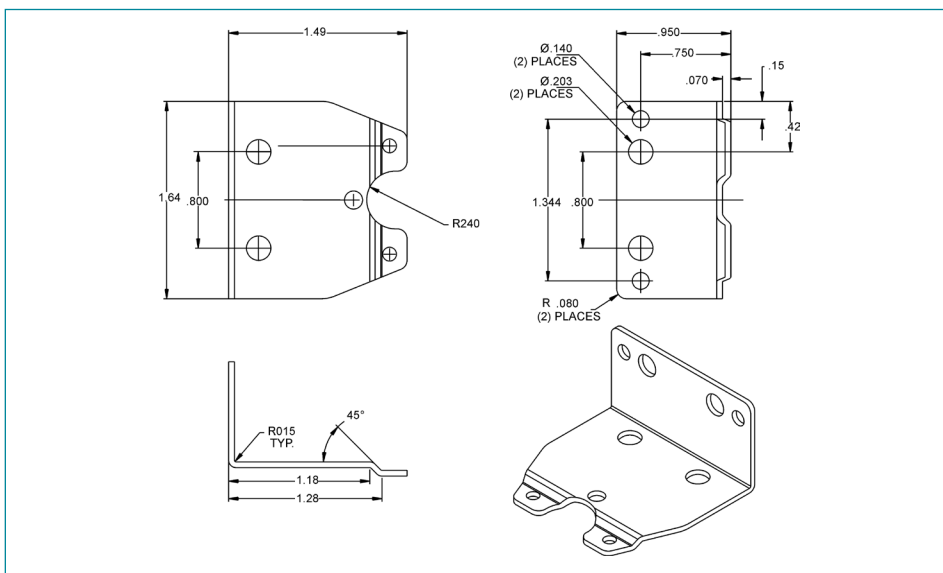

Figure 5: "L" Bracket



NS2 SWITCH TECHNICAL SPECIFICATIONS

MATERIAL	
Body	Glass-filled polycarbonate.
Diaphragm	Post-cured silicone.
Terminals	Copper alloy.
Contacts	Fine silver.

OPERATION	
Operating Range	0.10"w.c to 10.0"w.c.
Max. Pressure Rating	14"w.c.
Mounting	Standard diaphragm: vertical or custom angle. Consult factory.
Operating Temperature	-40 to +88C. (-40 to +190F).
Sample Line Connections	Black positive. Gray negative..
Sample Medium	Air and byproducts of combustion that will not degrade silicone or polycarbonate.
Product Life	100,000 cycles minimum.

ELECTRICAL	
Electrical Rating	Standard Silver Contacts: SPDT Electrical load: 1/10 HP @120 to 277 Vac; 28 VA pilot duty @ 24 Vac; 125 VA pilot duty @ 120 Vac.
Contact Arrangement	SPDT.
Electrical Connectors	Standard quick-connect terminals: 1/4" x 0.032 .

GENERAL	
Approvals	UL, CUL, CSA, CE, Australian Gas Assoc.
Accessories	Consult Factory.