

Application Data

CONTENTS

	PAGE
GENERAL	1
SYSTEM DESIGN CONSIDERATIONS	6
Compressor Ratings	6
Environmental Considerations	6
Code Agency Listings	6
Suction and Discharge Pressure Limits	6
Interstage Pressure	6
Discharge Temperature Limits	6
06CC Thermal Protection	7
Start/Stop Limits	7
Refrigerant Migration and Flooding	7
Suction Piping	7
Interstage Piping	8
Discharge Piping	10
Vibration Isolation	10
System Cleanliness and Dehydration	10
LUBRICATION SYSTEM	10
Recommended Oils	10
Oil Pressure Protection	10
Oil Temperature Limits	11
Oil Level	11
Oil Separator and Oil Return	11
Oil Equalization – Parallel Compressors	11
CAPACITY CONTROL	11
Unloaded Operating Guidelines and Limits	11
Variable Speed Unloading	11
Suction Line Pulse Width Modulation (PWM) Flow Modulation	12
ELECTRICAL DATA	12
Allowable Voltage Range	12
06CC 17-37 cfm Overcurrent Protection	12
06CC 17-37 cfm Electrical Data	13
06CC 50-99 cfm Overcurrent Protection	14
06CC 50-99 cfm Electrical Data	16
RLA for Variable Speed 06CC Compressors ..	18
COMPRESSOR ACCESSORIES	18
Variable Speed Drives	18
Internal Pressure Relief Valves	18
Suction Inlet Strainer	18
Discharge Mufflers and Baffle Plates	18
Crankcase Heaters	18
Cylinder Head Cooling Fans	18
Liquid Injection	18
Compressor Mounts	18
Compressor Service Valves	18

GENERAL

Carlyle 06CC semi-hermetic 2-stage compressors are ideally suited for commercial refrigeration, process cooling, and environmental chambers. They are extremely flexible and may be used with many of the new refrigerant blends, such as R-448A, and R-449A, in addition to the former refrigerants, such as R-404A, R-407A, R407C, R407F, R-507 and R-22. The compressors may be operated at fixed speed on 50 or 60 Hz and are also capable of variable speed operation. The 06CC compressors are listed with UL (Underwriters' Laboratories) and CSA (Canadian Standards Association) and comply with the low voltage directive of the European Community to carry the CE mark. For model number nomenclature, see Fig. 1. See Fig. 2 for key features of the 06CC 17-37 cfm models and Fig. 3 for the 06CC 50-99 cfm models.

High Efficiency Valve System

The valve system utilizes low lift valves and high flow ports to reduce valve losses, maximize efficiency, and reduce valve stress. Carlyle's valves are made of Swedish steel, the finest material available for this application.

Contoured Pistons and Vented Connecting Rods

The pistons are contoured, allowing the suction valves to mate up with the recess in the pistons, resulting in reduced clearances, which increases both capacity and efficiency. The connecting rods are also vented to provide premium bearing lubrication and longer life.

Auto-reversing High Flow Oil Pump

The positive displacement vane type oil pump is extremely durable and produces a high volume of oil flow in either direction of shaft rotation. The 06CC oil pump will produce oil pressure quickly, reducing the potential for nuisance oil pressure trips.

Override Oil Sump

On start-up, oil level can temporarily drop too low, causing unnecessary wear in other compressor designs when, on shut-down, the oil is diluted by refrigerant. The override oil sump holds extra oil in the crankcase to prevent normal oil migration from dropping the oil level below the safe lubrication range.

High Efficiency Heavy Duty Motors

These motors have the latest insulation systems, which help to prevent motor burnouts, especially during hot weather periods when operating pressures, temperatures, and currents (amps) are high.

Suction Inlet Screen

The suction inlet screen prevents scale or abrasives from entering the compressor and shortening the life of the motor and compressor.

Oversized Gas Passages

The oversized gas passages generate less turbulence, lower pressure drops, and more efficient motor cooling by interstage gas that has a more economical operation and longer life.

Main Bearings — Steel Backed PTFE

Teflon¹ (PTFE) material is used on bearing surfaces to provide greater load carrying ability than other types of materials and is also less susceptible to damage from overheating or liquid refrigerant.

Crankcase Oil Heater

This field-installed accessory warms crankcase oil to reduce refrigerant migration that occurs during shutdown periods.

1. Teflon is a registered trademark of DuPont.

06CC 6 65 E 201

06CC COMPRESSORS

Design Variable:

- 101 = Single Pack, W/O Valves, with Oil
- 102 = Single Pack with Valves and Oil
- 103 = Single Pack, Service W/O Valves and Term. Box or Oil
- 201 = Single Pack, W/O Valves or Oil
- 202 = Single Pack with Valves
- S = Oil Sensor Block and OPSS sensor (shown as the 10th digit)

Electrical Characteristics:

- A = 415-3-50, XL and PW
- B = 415-3-50, XL
- C = 415-3-50, PW
- D = 208/230-3-60, XL
- E = 208/230/400/460-3-50/60
- F = 400/460-3-50/60, XL and PW
- G = 400/460-3-50/60, XL
- H = 400/460-3-50/60, PW
- J = 575-3-60, XL and PW
- K = 230-3-60, PW
- L = 220-3-50, XL and PW
- M = 220-3-50, XL
- N = 220-3-50, PW
- P = 220/346/380-3-50/60, XL and PW
- Q = 380-3-60, XL

Displacement(in Cfm at 1750 rpm) (See Note below)

Motor Size and Protection:

5th Digit	Motor Size	Overload Variable
0	15 FT-LB / 5 HP	Electromechanical Overcurrent Protection (*No Longer Available)
A	15 FT-LB / 5 HP	115/240V Control Voltage, Electronic Overcurrent Protection
B	15 FT-LB / 5 HP	24V AC Control Voltage, Electronic Overcurrent Protection
C	15 FT-LB / 5 HP	24V DC Control Voltage, Electronic Overcurrent Protection
1	20 FT-LB / 6.5 HP	Electromechanical Overcurrent Protection (*No Longer Available)
D	20 FT-LB / 6.5 HP	115/240V Control Voltage, Electronic Overcurrent Protection
E	20 FT-LB / 6.5 HP	24V AC Control Voltage, Electronic Overcurrent Protection
F	20 FT-LB / 6.5 HP	24V DC Control Voltage, Electronic Overcurrent Protection
2	24 FT-LB / 7.5 HP	Electromechanical Overcurrent Protection (*No Longer Available)
G	24 FT-LB / 7.5 HP	115/240V Control Voltage, Electronic Overcurrent Protection
H	24 FT-LB / 7.5 HP	24V AC Control Voltage, Electronic Overcurrent Protection
J	24 FT-LB / 7.5 HP	24V DC Control Voltage, Electronic Overcurrent Protection
3	24 FT-LB / 7.5 HP	Electromechanical Overcurrent Protection (*No Longer Available)
K	24 FT-LB / 7.5 HP	115/240V Control Voltage, Electronic Overcurrent Protection
L	24 FT-LB / 7.5 HP	24V AC Control Voltage, Electronic Overcurrent Protection
M	24 FT-LB / 7.5 HP	24V DC Control Voltage, Electronic Overcurrent Protection
5	45 FT-LB / 15 HP	Not Factory Installed, External Overcurrent Protection Required
6	60 FT-LB / 20 HP	Not Factory Installed, External Overcurrent Protection Required
7	75 FT-LB / 25 HP	Not Factory Installed, External Overcurrent Protection Required
8	90 FT-LB / 30 HP	Not Factory Installed, External Overcurrent Protection Required

Compressor Type:

- 06CC = Compound Cooling Model
- 06CY = Service Compressor
- 06C8 = Compressor, Special

Information in shaded area is no longer available in standard factory production.

NOTE: USE OF "Cfm" AS MODEL SIZE DESIGNATION

Carlyle uses the "Cfm" designation in the model number to identify the compressor size. The Cfm values are the sixth and seventh digits of the model number. See example above. Carlyle offers two series of compressors based on body size. The smaller compressors, from 8 to 37 Cfm, are referred to as "D" size units (model number "06D"). The larger compressors, from 50 to 99 Cfm, are referred to as "E" size units (model number "06E"). The 06CC, or Compound Cooling compressors, are made in 16 to 37 Cfm and 50 to 99 Cfm sizes. The 16 to 37 Cfm compressors use "D" size bodies. The 50 to 99 Cfm compressors use "E" size bodies.

NOTE: METRIC MEASUREMENTS

The compressors are built using English units: inches, foot-pounds, pints, etc. A corresponding metric measurement has been added to all the English units in this guide. These metric measures are a guide only, having been rounded to the nearest whole number, and therefore are not meant to be an exact mathematical conversion.

Fig. 1 — Model Number Nomenclature

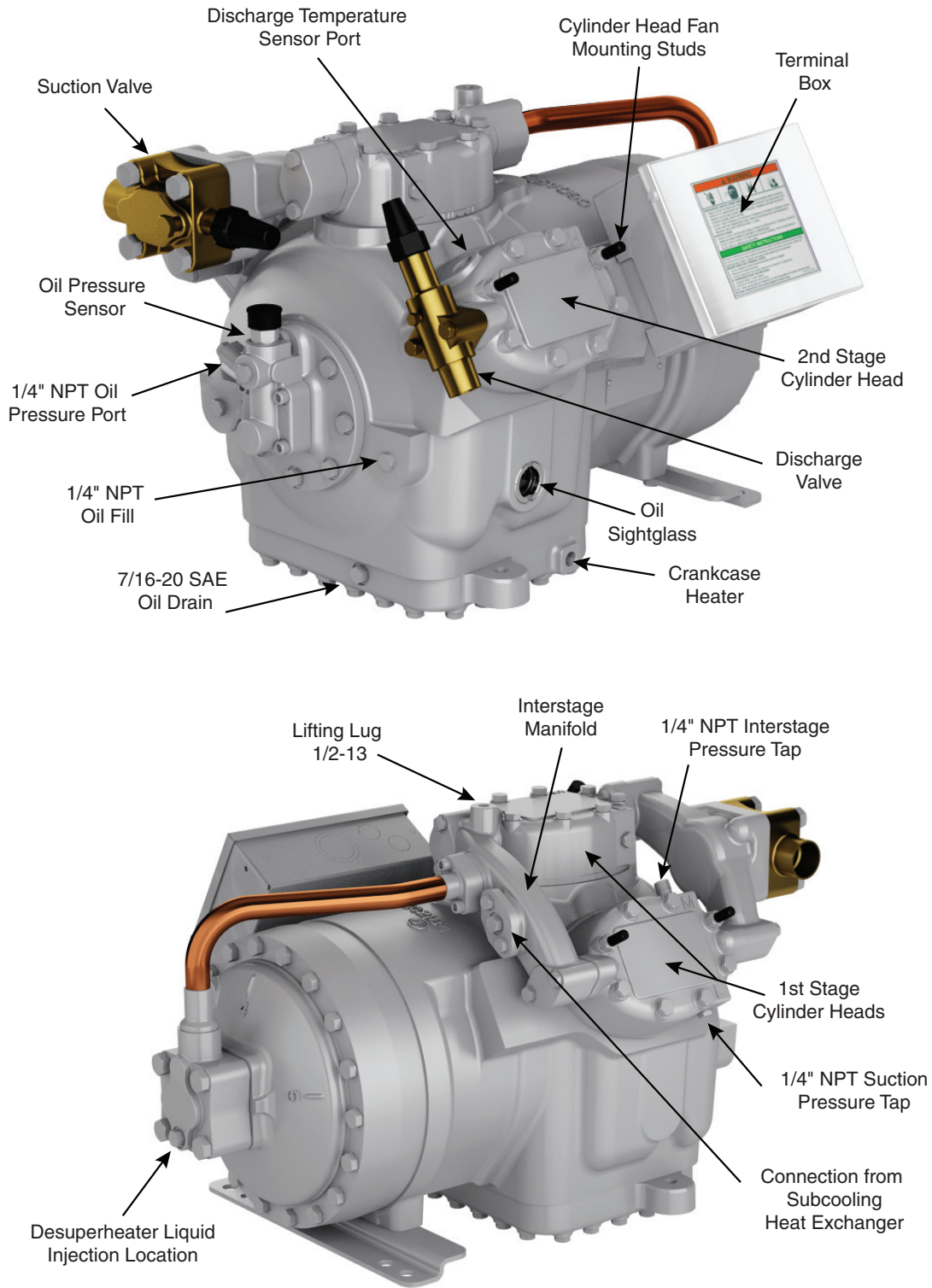

Fig. 2 — Key Features, 06CC 17-37 cfm Compressor Models

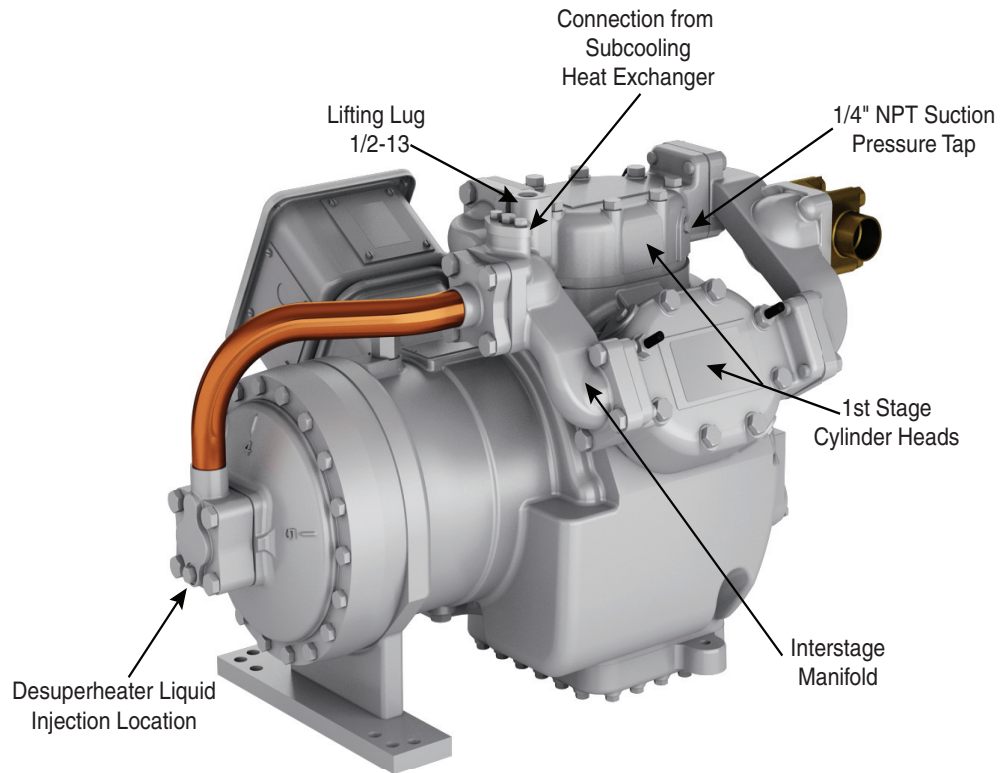
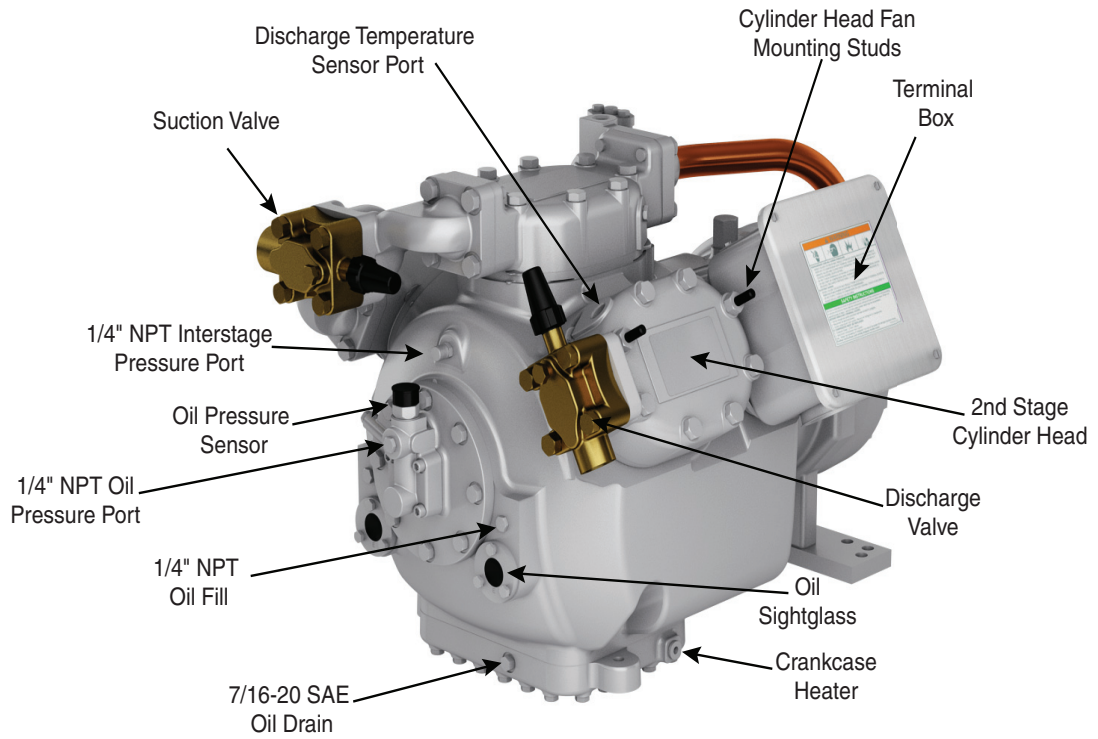

Fig. 3 — Key Features, 06CC 50-99 cfm Compressor Models

SYSTEM DESIGN CONSIDERATIONS

Compressors are available for operation in air conditioning as well as low and medium temperature refrigeration application. This guide provides recommendations and requirements for the successful application of the compressors in these applications.

Compressor Ratings

Performance data is available using Carlyle's CARWIN™ performance rating software at www.carwin.carlylecompressor.com. As with all reciprocating compressors, a 'run-in' period of 50 to 100 hours may be required to obtain the published performance. Operating envelopes will vary by compressor model and refrigerant. These can be found within the CARWIN rating software.

Environmental Considerations

DESIGN PRESSURES

Table 1 shows the relevant design pressures for the 06CC compressor applications.

Table 1 — Design Pressures

	COMPRESSOR APPLICATION	DISCHARGE PRESSURE psia (bar)	SUCTION PRESSURE psia (bar)
MAXIMUM OPERATING PRESSURE*	Varies by model and refrigerant	See Operating Envelopes in CARWIN rating software, www.CARWIN.carlylecompressor.com	
MAXIMUM ALLOWABLE PRESSURE†	All 06CC compressors and all refrigerants	465 psia (32.0 bar)	285 psia (20.7 bar)
PROOF TEST PRESSURE**		515 psia (35.5 bar)	330 psia (22.8 bar)
LEAK TEST PRESSURE††		240 psia (16.5 bar)	

* Maximum Operating Pressure is the maximum pressure permissible under normal operation.

† Maximum Allowable Pressure is the maximum pressure permissible under atypical circumstances including but not limited to the following:

1. Maximum ambient temperature
2. Setting of any over-pressure relief devices
3. Operating, standby, and shipping conditions
4. System component failure (fan motor, condensing cooling water, etc.)

** Proof Test pressure is the pressure to which the compressor is tested at the factory to validate its integrity.

†† Leak Test Pressure is the pressure to which the compressor is leak tested at the factory.

ALLOWABLE AMBIENT TEMPERATURES

All 06CC compressors have a non-operating (storage, no refrigerant in compressor) temperature range of -40°F to 180°F (-40°C to 82.2°C). The 06CC compressor is designed to operate in an ambient temperature range of -25°F to 130°F (-31.7°C to 54.4°C). These are ambient air temperature ranges only; the Design Pressures section above defines the pressure limitations that correspond to standstill temperatures.

Code Agency Listings

The 06CC compressors have both UL and CSA recognition under the file number SA4936. All UL recognized 06CC compressors have terminal enclosures that are suitable for outdoor use equipment as a sole enclosure.

Certain models comply with the European Union's Low Voltage Directive and Machinery Directive. The CE mark is included on the nameplates of those compressors. These models also comply

with the UK Electrical Equipment Safety Regulation and Machinery Safety Regulation. The UKAC mark is included on the nameplates of those compressors.

For the code agency listings to be valid, the compressor may only be applied with approved refrigerants listed in the Installation Instructions, and all requirements listed in those Installation Instructions and this Application Guide must be followed.

Suction and Discharge Pressure Limits

Operating envelopes of the compressor models will differ with each model and refrigerant. These operating envelopes are provided in the CARWIN rating program.

During pulldown, as the compressor should not be subjected to low suction pressures for any extended time, a low-pressure switch is required on all 06CC applications.

IMPORTANT: Low pressure switches must be connected to the low-pressure port. The crankcase of all 06CC models operates at intermediate pressure.

Where an extended pulldown period is expected (i.e., for large refrigeration systems), the suction pressure must be limited by some positive means.

Two-stage 06CC models may be applied in systems that utilize air-cooled condensers. Carlyle limits the design saturated discharge temperature in these systems to a maximum of 130°F (54.4°C) and a minimum of 70°F (21.1°C). Allowing saturated discharge temperatures to fall below 70°F (21.1°C) does not significantly affect energy usage but is not recommended and may lead to increased valve stresses and potential valve failure. Carlyle requires the use of a discharge pressure regulator on all single and multiple compressor applications. The pressure regulator must be set at a minimum pressure corresponding to 70°F (21.1°C) saturated (dew point).

Interstage Pressure

The intermediate pressure may be approximated using the geometric mean of the suction and discharge pressures, as shown in the equation below.

$$P_{\text{interstage}} \approx \sqrt{P_{\text{suction}} \times P_{\text{discharge}}}$$

All pressures are absolute

The intermediate pressure of the Carlyle 06CC compressors will vary based on suction and discharge pressure as well as the amount of interstage flow due to subcooling and desuperheating.

If a subcooler is not used, the intermediate pressure may be up to 30 psi (2.07 bars) lower than the calculated pressure. Saturated intermediate temperatures can be estimated using the CARWIN rating software available at www.CARWIN.carlylecompressor.com.

Discharge Temperature Limits

The actual discharge gas temperature at the compressor discharge service valve must not exceed 275°F (135°C). For hydro-fluorocarbon (HFC)/polyolester (POE) applications, the maximum recommended discharge temperature is 250°F (121.1°C). For a given refrigerant, this discharge temperature depends upon the compression ratio as well as the suction return gas temperature.

06CC Thermal Protection

All 06CC models are supplied with a discharge temperature sensor located in the cylinder head of the compressor. This sensor is designed to open at 295°F, ±5°F (146.1°C, ±2.8°C), and to close at 235°F (112.8°C). The discharge temperature sensor operates as an automatic reset device; however, Carlyle recommends that it is wired into the control scheme in a manner to function as a manual reset device. The sensor will open on temperature rise and close on temperature fall. The thermostat pilot duty contacts are rated for a 125 sealed va and for an inrush of 1250 va. They are automatically resetting and provide complete thermal protection.

In addition to the discharge temperature sensor, for variable speed 06CC 17-37 cfm applications, Carlyle requires that the motor winding thermostat embedded within the windings be connected into the system controls to protect against high motor temperatures when the compressor runs at low speeds for extended periods of time. The internal thermostat trips (opens) at 221°F (105°C) and resets at 181°F (82.8°C). The embedded thermostat has a rated voltage of 277 v and contact rating of 1.6A.

Start/Stop Limits

Compressor start transients are known to place higher stress on the motors and running gear of a compressor. Carlyle has proven a correlation between excessive starts and higher failure rates. Carlyle 06CC compressors must not start more than 12 times per hour. Carlyle also recommends that the compressors run for at least 5 minutes after each start to aid in proper oil return. In refrigeration racks, well controlled compressors will generally have no more than 75 starts per day in low temperature racks and 100 starts per day in medium temperature racks. Where feasible, Carlyle recommends adding cycle counters that can be used in system diagnostics and troubleshooting.

Refrigerant Migration and Flooding

Liquid refrigerant, or even excessive amounts of entrained liquid particles in the suction gas, must be kept out of the compressor by proper system design and compressor control. Under running conditions, the presence of liquid refrigerant in the compressor tends to break down the oil film on the cylinder walls, resulting in increased wear to the cylinder walls and piston rings and possible compressor damage. Furthermore, excessive liquid in

the cylinders causes hydraulic compression, which can create cylinder pressures as high as 1500 psi (103 bar). This hydraulic loading can cause suction and discharge valve and gasket failures to occur, while also subjecting the connecting rod, piston, and main bearings to excessive loading.

During compressor “off” cycles, gravity, thermal action, and refrigerant absorption will result in a refrigerant and oil mixture in the compressor crankcase. Gravity flow can be prevented using reverse traps in the piping, but thermal action and the absorption of refrigerant by lubricating oil cannot be eliminated solely by piping design. To minimize the absorption of refrigerant into the oil, Carlyle requires the use of crankcase heaters. It is important, however, to never energize the crankcase heater while the compressor is running because this may over-heat the compressor oil.

Suction Piping

Suction lines and suction risers must be sized to ensure adequate velocity for oil return, taking into account the potential reduction in mass flow associated with changes in operating condition and unloading of the compressors. The lack of proper line sizing may result in premature compressor failure due to oil slugging. Improper suction line sizing can also cause oil loss to the system, causing oil starvation and premature failure of the compressors.

The design of Carlyle’s 06CC model compressors draws suction gas directly into the low-stage cylinders. Laboratory testing has shown that the valves are tolerant to liquid flooding; however, extreme flooding and liquid “slugs” may cause damage to the compressor. Carlyle requires the use of suction line accumulators to protect the 06CC compressors from liquid refrigerant and oil “slugs.” For multiple compressor systems, an oversized suction manifold that is functionally equivalent in terms of mitigating slugging and having appropriate means for oil return is also acceptable. Suction manifolds are recommended to be located below their respective compressor inlet locations, as shown in Fig. 4.

Alternately, if the manifolds are located above the inlets, then reverse traps must be installed in each compressor inlet feeder, as shown in Fig. 5. In both situations, each compressor feeder line should include a dip tube in the header that facilitates oil return to each compressor.

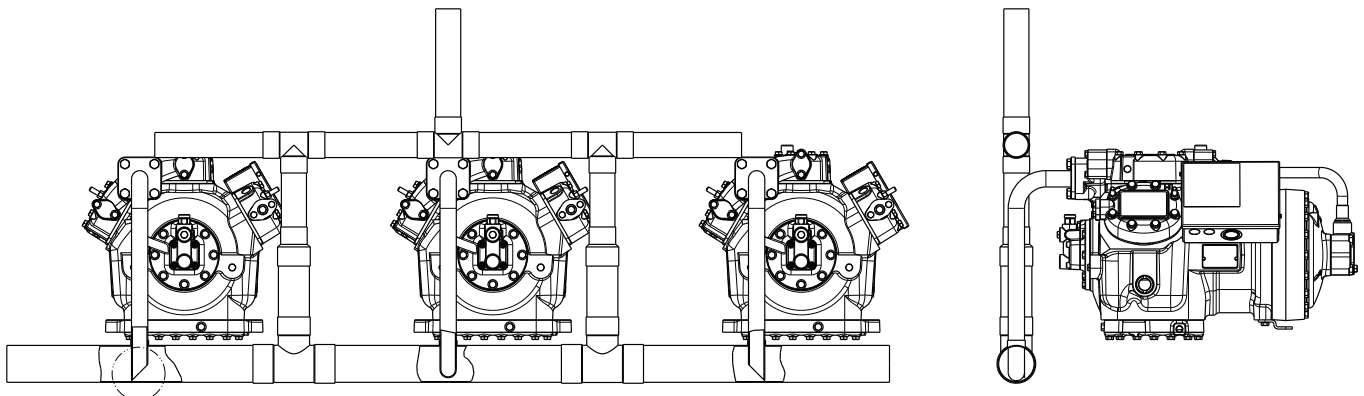

Fig. 4 — Suction Header BELOW Compressors

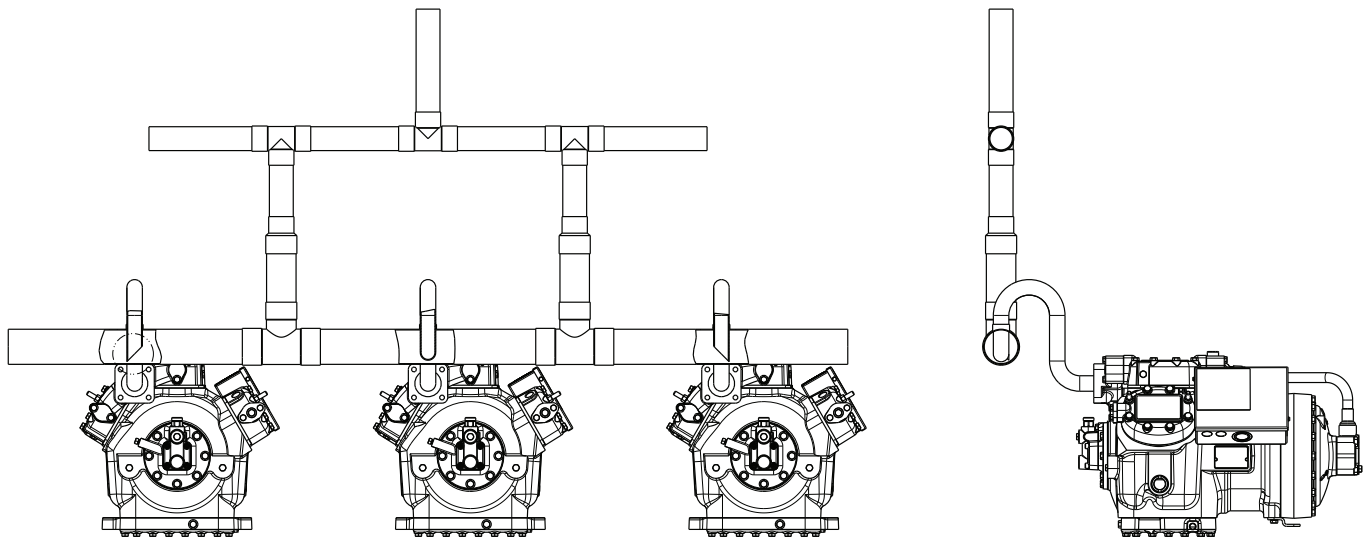

Fig. 5 — Suction Header ABOVE Compressors

The end of these dip tubes should be beveled and configured as shown in Fig. 6. Alternate means for oil return should be reviewed with Carlyle Application Engineering prior to installation.

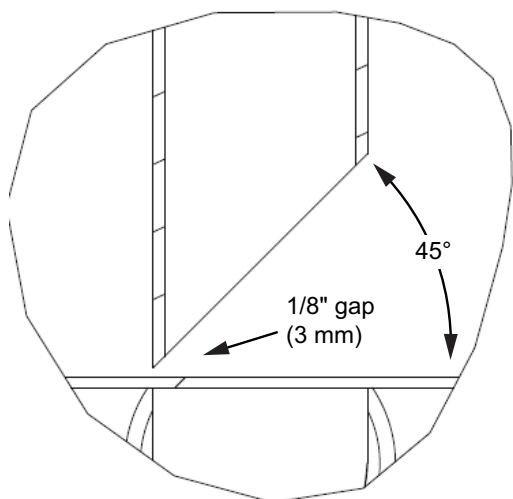

Fig. 6 — Pickup Tube Details

Interstage Piping

Figures 7, 8, and 9 all show the recommended implementation of a subcooler in the interstage piping. The subcooler in these systems is controlled through the use of a single thermal expansion valve (TXV) that is fed from a branch off of the main liquid line. A small amount of liquid refrigerant is expanded through the TXV, into the subcooler / economizer, to cool the remaining liquid refrigerant. The suction gas from that work is typically superheated ~25°F (~13.9K) through TXV adjustment and then flows from the subcooler into the interstage section of the 06CC model compressor, providing some (or all) of the

desuperheating needed for the refrigerant gas entering the motor compartment. A normally-closed liquid line solenoid valve must be installed prior to the subcooler TXV. The solenoid valve must be controlled to close when all of the compressors are OFF. The subcooler must be connected in a parallel-flow configuration to reduce the potential for excessively superheated suction gas returning from the subcooler to the interstage connection of the compressor. Highly superheated gas entering the interstage can cause TXVs to operate in an unstable manner. Variation in condensing pressures (more prevalent in air-cooled systems) will affect interstage pressures in the system and may result in varying liquid temperatures leaving the subcooler.

Carlyle recommends brazed plate heat exchangers for use as subcoolers on single and multiple compressor systems. These heat exchangers should be selected based on the estimated subcooling load, which can be estimated using the CARWIN rating software. This rating program is available online at www.CARWIN.carlylecompressor.com.

Interstage check valves are not required with Carlyle 06CC model compressors. Intercooling the interstage gas in an external heat exchanger is not recommended and may result in liquid flooding that voids the compressor warranty.

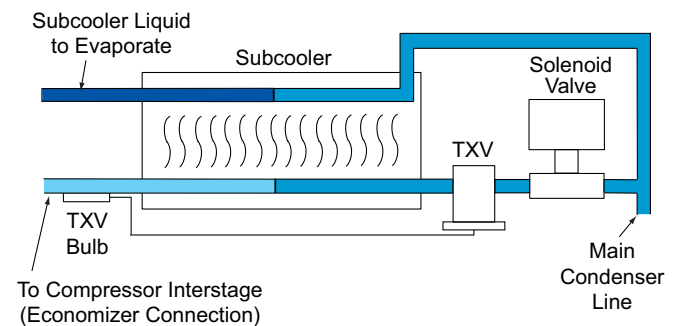

Fig. 7 — Parallel Flow Subcooler

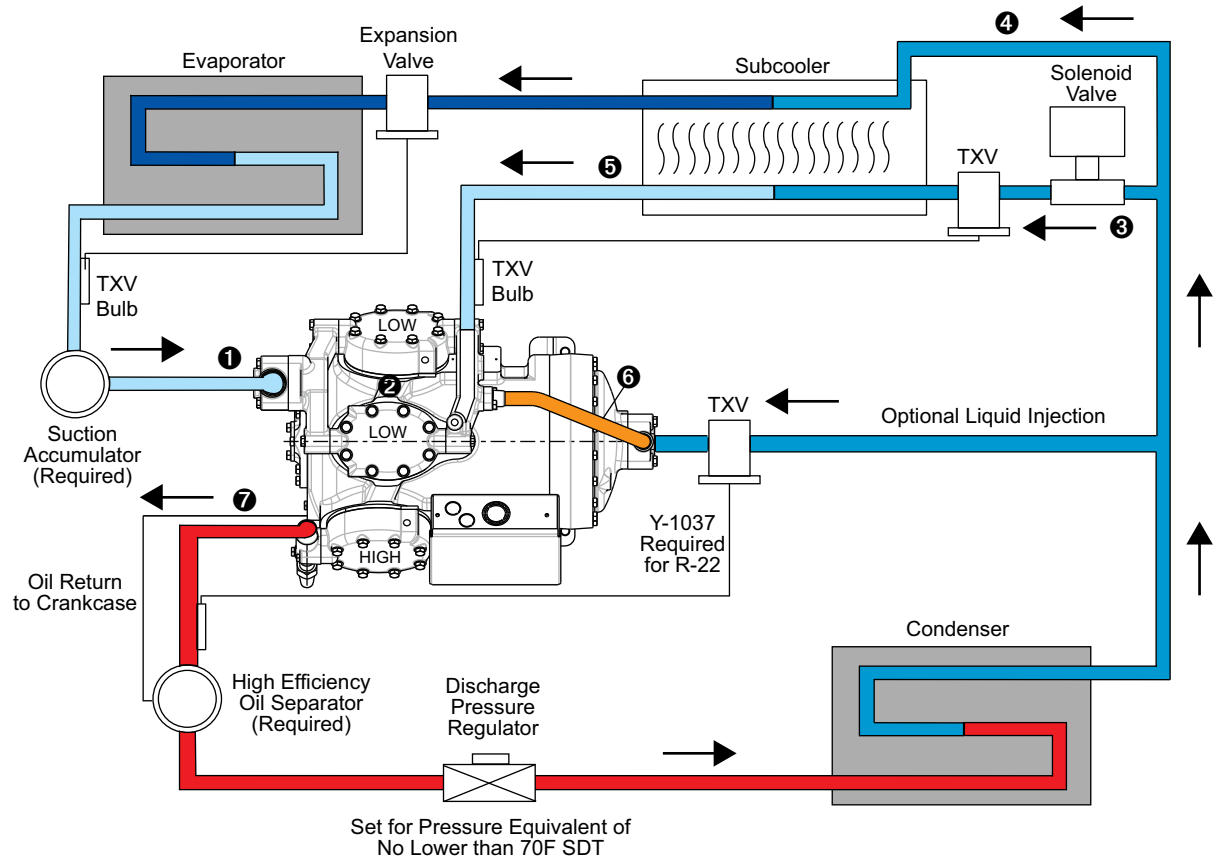

Fig. 8 — Single Compressor 06CC System Piping

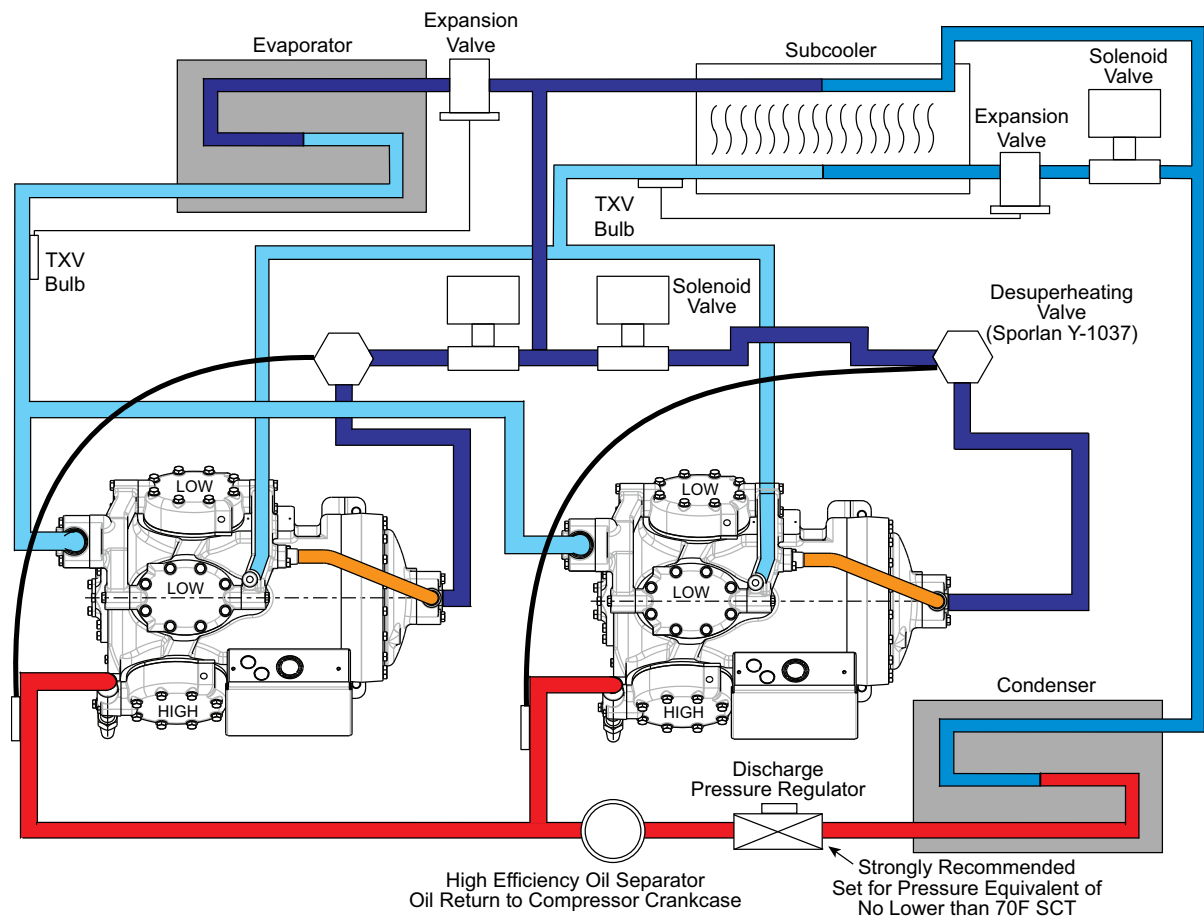

Fig. 9 — Multiple Compressor 06CC System Piping

Discharge Piping

The discharge should be piped to avoid logging oil and excessive vibration to protect against leaks from fatigue cracking in the joints. Care should be taken when connecting 2 or more compressors in parallel. It is best to connect each parallel compressor into the branch connection of a "Tee." Compressor discharge lines should never be setup in a bullhead fashion. (See Fig. 10.)

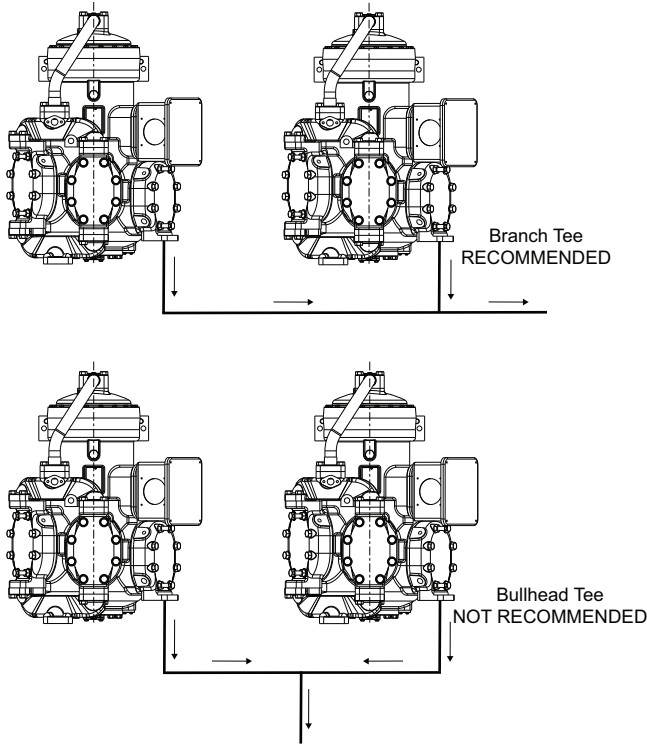

Fig. 10 — Discharge Header Layout

Consult the Carrier System Design Manual (Part 3 — Piping Design) or the ASHRAE Manual — Systems Volume for more details of good system piping practices.

Vibration Isolation

On installations where noise and vibration must be kept to a minimum, it is desirable to use vibration mounts under the compressor unit, even though the compressors may be spring mounted. Proper precautions must be taken to prevent the transmission of compressor vibration through the piping system. It is also recommended to design the suction line with sufficient "spring," so the suction service valve can be moved aside for access to the suction strainer. Compressors applied in spring-mounted systems should also have adequate flexibility in the suction and discharge piping to avoid the excessive stresses caused by the start and stop "kick" of the compressor. These excessive stresses can typically be avoided by adding bends in the piping in different directions. Many systems have been designed with compressors mounted to the bases. In these cases, it is important that the compressors be properly torqued to the base, or the compressor may produce a "rattle" or transmit excessive vibration to the base.

System Cleanliness and Dehydration

Clean and dry systems are essential for long compressor and motor life and satisfactory operation. Compressor lubricants require special attention; excessive moisture when combined with heat and refrigerant can form damaging acids. The recommended limit for moisture is less than 50ppm for compressors lubricated with mineral oil (MO) or alkylbenzene (AB) lubricants and 100ppm for POE lubricants.

Liquid line refrigerant filter-driers maintain low moisture content and, in the event of a motor burnout, prevent contamination of the evaporator and other parts of the refrigeration system. Liquid line moisture indicators are recommended in all systems to provide a continuous check on the system's moisture content.

LUBRICATION SYSTEM

Recommended Oils

The 06CC model compressors are shipped without oil. Table 2 details the Carlyle-approved oils for use in 06CC applications. All POE oils will readily absorb and retain moisture from ambient air and should be used immediately upon opening the factory-sealed container. Note that some of the POE oils shown are not approved for use in any low temperature applications.

Table 2 — Recommended Oils

MANUFACTURER	BRAND NAME
For HFC Refrigerants	
Totaline (POE)	P903-1701
Castrol (POE)	E68
ICI Emkarate (POE)	RL68H
Lubrizol Lubrikuhl (POE)	2916S
Texaco Capella (POE)	HFC 68NA
Totaline (POE)	P903-1001*
Castrol (POE)	SW68*
Mobil Arctic (POE)	EAL68*
For HCFC and CFC Refrigerants	
Totaline (MO)	P903-0101
Witco Suniso (MO)	3GS
IGI Petroleum (MO)	Cryol150
Texaco Capella (POE)	WFI32-150
Totaline (AB)	P903-2001
Shrieve Chemicals (AB)	Zerol150

* Do not use in low temperature applications.

LEGEND

AB — Alkybenzene oil
MO — Mineral oil
POE — Polyolester-based oil

Oil Pressure Protection

Differential oil pressure (oil minus suction pressure) is important for good compressor reliability. Carlyle recommends a 120-second time delay in the oil safety switch. The oil safety switch protects the compressor when lubrication is lost for more than 120 seconds. The switch closes the control circuit at start-up, allowing the compressor to run for 120 seconds. Operating oil pressure must reach the minimum required start pressure above suction pressure within 120 seconds for the switch to remain closed, which allows the compressor to run. If the operating oil pressure falls to below the minimum stop pressure above suction for longer than 120 seconds, the switch will open the control circuit, shutting down the compressor. Oil pressure protection devices must be manual reset type.

Use of oil pressure protection is required on all fixed and variable speed 06CC compressor applications, single and parallel compressors.

The 06CC compressors are available with factory-installed oil pressure protection. (See Fig. 11.) This factory-installed sensor eliminates the need for any field piping connections. The electronic portion of this oil pressure protection is available as a separate accessory for integrating into the system controls.



Fig. 11 — Factory-Installed Oil Pressure Protection

Oil Temperature Limits

The oil temperature in the sump must not exceed 160°F (71.1°C).

Oil Level

All refrigeration compressors must have adequate lubrication to ensure trouble-free operation and a long life. When starting up any new system, some oil will be lost to coat the inside of the piping, some will be lodged in low velocity areas of the system, and some will be kept in circulation. This loss must be made up by adding oil to the system after the initial start-up.

Very low compressor oil levels can cause complete loss of lubrication and may result in an immediate compressor failure if not protected against. The loss of oil can also be caused by flooded starts or refrigerant migrating into the oil during an off period and pulling the oil out of its sump during the sudden pressure drop of a start-up. Excessively high oil charges can shorten the compressor life by increasing oil circulation rates, which may result in oil slugging as it returns to the compressor.

Figure 12 shows the minimum and maximum recommended oil levels for the 06CC compressors. The 06CC 50-99 cfm compressor may have 2 sightglasses that may show different levels during operation. This difference is due to the rotation of the crankshaft.

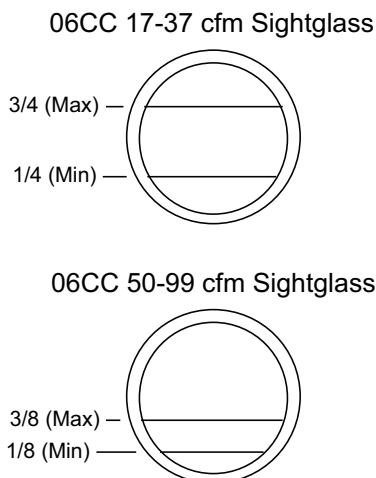

Fig. 12 — Oil Sightglass Level

The oil level should be observed in the sightglass only when the compressor is warmer than the evaporator, i.e., immediately after shutdown or when the crankcase heater has been energized. The level observed when the compressor is not running for a long period may be a mixture of oil and refrigerant, which would not be a true indication of the oil level when the compressor is running.

Oil Separator and Oil Return

All 06CC model compressors have lower oil circulation rates than single-stage compressor models. Carlyle requires the use of a high-efficiency oil separator in all 06CC model applications. Preferable oil separator designs provide increased efficiency as mass flow rates decline. For HFC refrigerant applications, Carlyle recommends oversized (125 percent to 150 percent of design loads), coalescing, or impingement type oil separator designs.

IMPORTANT: The crankcase of the 2-stage 06CC models is at an intermediate pressure. The oil reservoir must be vented (a 20 lb check valve is recommended) to the interstage manifold, NOT the suction manifold, as is typical with single-stage compressors. Oil return to the 06CC model compressors must be done at the crankcase of the compressor, NOT the suction line.

Oil Equalization – Parallel Compressors

The 06CC model compressor types must not be applied with motor barrel equalization or crankcase equalization (through the floats). These equalization methods are relevant only for the 06D and 06E single-stage models.

When 2 or more 06CC compressors are to be connected in parallel, or if compressors of different displacements are to be connected in parallel, an oil control system utilizing an oil separator, oil reservoir, and floats is recommended. Several manufacturers supply this type of oil management system. It is important that floats are properly selected to control the oil levels as described in the Oil Level section.

CAPACITY CONTROL

Unloaded Operating Guidelines and Limits

The ability to return oil back to the compressor is a consideration that the system designer must accommodate from the reduced flow rates when the compressors are unloaded. All system piping, especially the suction line, must consider oil return for both full and part load operation. See the Refrigerant Migration and Flooding and Suction Piping sections on page 7 for additional piping recommendations.

To increase gas velocities and help return oil to the compressors, Carlyle recommends that the system controls bring the compressor to its nominal flow rate for at least 60 seconds after any 2 hours of continuous unloaded operation. For variable speed systems, this nominal condition means 60 Hz speed, and for suction line flow modulation, this means allowing full uninterrupted flow for 60 seconds.

Variable Speed Unloading

Carlyle 06CC compressors are approved for variable speed applications. Conversion of older compressor models may require an upgrade of internal hardware. Carlyle Application Engineering should be consulted for any conversion of older compressors to variable speed operation. All compressors applied in variable speed applications must use the

factory-installed oil pressure protection switch. The use of alternate oil pressure protection must be approved by Carlyle Application Engineering.

The 06CC compressors are approved for a speed range of 30 to 60 Hz. Consult Carlyle Application Engineering for wider speed range requirements. At the lower end of the speed range, the system design should take care to manage the return gas temperatures to avoid excessive superheat or liquid floodback. Either can adversely affect the oil viscosity, oil pressure, and thus bearing life. Carlyle recommends that suction superheats be maintained in the range of 10°F to 25°F (5.6K to 13.9K).

Vibration in system components should be carefully evaluated in variable speed systems. During the design and/or commissioning phase of a new installation, the entire system must be checked for excessive vibrations, with a particular focus on these frequency ranges and multiples thereof. Any system resonance issues that cannot be resolved by clamping must be avoided within the programming of the variable speed drive.

At a constant suction and discharge pressure condition, the current draw of the motor will not change as the shaft speed changes. Motor current draw changes only as the shaft torque changes based on operating conditions.

Suction Line Pulse Width Modulation (PWM) Flow Modulation

Suction line PWM flow modulation allows continuous modulation of the compressor capacity using a solenoid valve installed in the suction line of the compressor. The controller will cycle the valve once every 30 seconds between the open and closed positions. The relative duration of the open versus closed times creates a time average flow rate to the compressor that can be continuously varied. See Carlyle literature 574-078 for more details.

ELECTRICAL DATA

Allowable Voltage Range

Table 3 lists allowable voltage ranges for 06CC compressors.

06CC 17-37 cfm Overcurrent Protection

Fixed speed 06CC 17-37 cfm compressors include a factory-installed electronic overcurrent protection module that interprets a signal from a positive temperature coefficient (PTC) triplet embedded in the stator windings and a current transformer located in terminal box. This module will shut down the compressor when it is operated at conditions exceeding the maximum continuous current draw for the compressor or when the winding temperatures exceed their limit.

The electronic overcurrent protection requires that a control voltage be supplied for the compressor protection module. This control voltage is included in the compressor model number. The system designer can select a compressor model with a control voltage of 120/240 vac, or 24 vac or 24 vdc.

The wiring diagrams for the 06CC 17-37 cfm compressors are shown in Fig. 13 (fixed speed) and Fig. 14 (variable speed).

The electronic overcurrent protection module is preprogrammed in the factory with the maximum continuous current (MCC) value as listed in the 06CC 17-37 cfm Electrical Data section on page 13.

Variable speed 06CC 17-37 cfm compressors may use the overcurrent protection features of the variable speed drive, providing that the drive is listed with UL for this purpose. The overcurrent setting of the drive must be consistent with the MCC value as defined in the 06CC 17-37 cfm Electrical Data section on page 13.

Table 3 — Allowable Voltage Ranges

06CC 17-37 cfm MODELS	06CC 50-99 cfm MODELS	60 Hz			50 Hz			
		DIGIT 8	NOMINAL	MIN	MAX	NOMINAL	MIN	MAX
D	E		208/230v-3-60Hz	187v	254v	200v-3-50Hz	187v	230v
G	E, F		460v-3-60Hz	414v	529v	400v-3-50Hz	342v	460v
J	J		575v-3-60Hz	518v	661v	—		

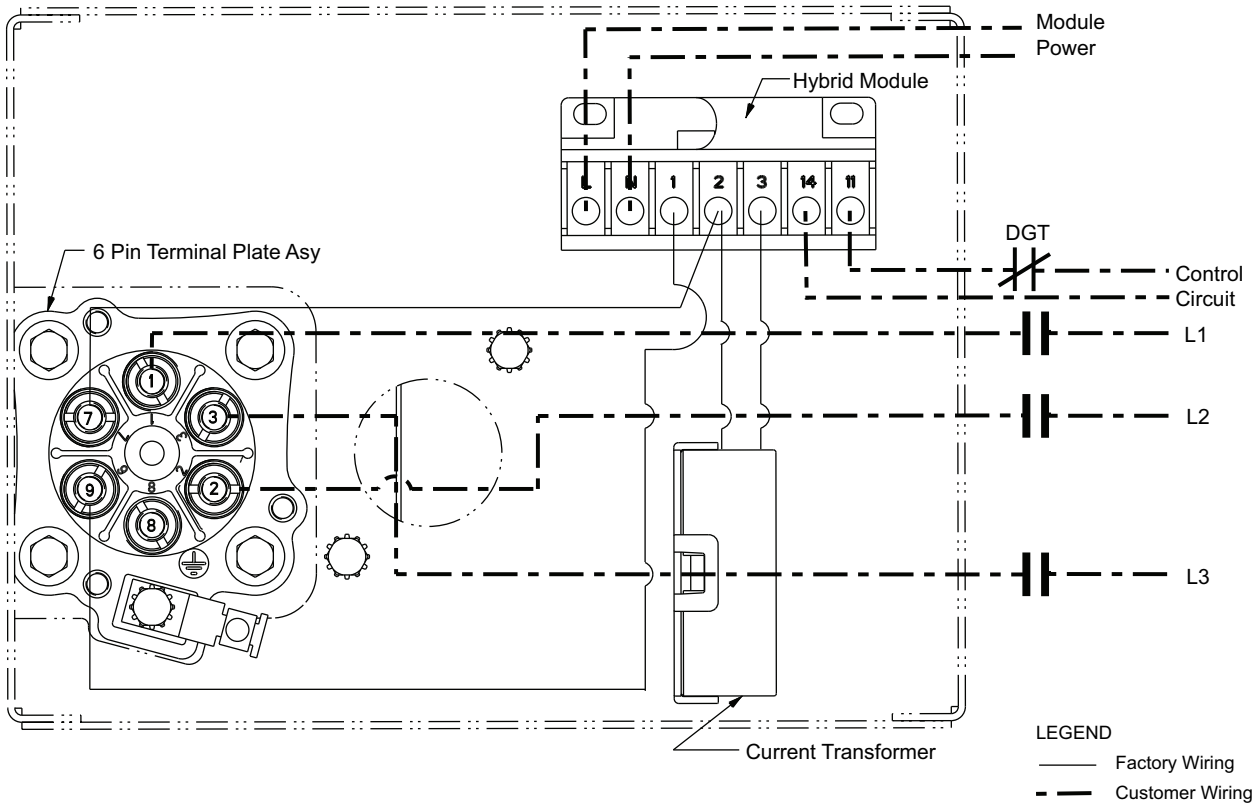

Fig. 13 — 06CC 17-37 cfm Fixed Speed Wiring Diagram

06CC17-37cfm, 6-Pin Term Plate
3-Lead Variable Speed
460V, 575V, 208/230V

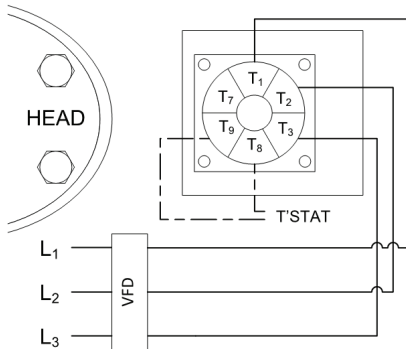

Fig. 14 — 06CC 17-37 cfm Variable Speed Wiring Diagram

06CC 17-37 cfm Electrical Data

Table 4 provides locked rotor current for across the line starting and MCC ratings for the 06CC 17-37 cfm compressors. MCC rating is a limitation of the compressor that is independent of both the refrigerant and application range.

For fixed speed applications, the 06CC 17-37 cfm factory-installed overloads are set to trip at this MCC value. Rated Load Amps (RLA) is based on the trip value of the overload device. Because the 06CC 17-37 cfm compressors are considered to be thermally protected, the RLA for compressors using these factory-installed overloads will be:

$$RLA = \frac{MCC}{1.56} \left. \vphantom{\frac{MCC}{1.56}} \right\} \text{ For 06CC 17-37 cfm with Factory Overload}$$

Table 4 — 06CC 17-37 cfm Electrical Data

COMPRESSOR MODEL			COMPRESSOR ELECTRICAL DATA					OVERLOAD PROTECTION DEVICE ELECTRONIC MODULE KIT				
			MAX kW	NOMINAL HP	VOLTS	MAXIMUM CONTINUOUS CURRENT	LOCKED ROTOR AMPS	CONTROL VOLTAGE	RATED LOAD AMPS ¹	SERVICE REPLACEMENT KIT NUMBER		
06CC	A17	J2S0	6.25	5	575-3-60	10.8	40	120/240Vac	6.9	06DA6606DBNB0108		
	B17							24Vac		06DA6606DBNC0108		
	C17							24Vdc		06DA6606DBND0108		
06CC	A17	D2S0			208/230-3-60	27	100	100	120/240Vac	17.3	06DA6606DBNB0270	
	B17								24Vac		06DA6606DBNC0270	
	C17								24Vdc		06DA6606DBND0270	
06CC	A17	G2S0			460-3-60	13.5	50	50	120/240Vac	8.7	06DA6606DBNB0135	
	B17								24Vac		06DA6606DBNC0135	
	C17								24Vdc		06DA6606DBND0135	
06CC	A25	J2S0			9.18	6.5	575-3-60	13.2	64	120/240Vac	8.5	06DA6606DBNB132
	B25									24Vac		06DA6606DBNC132
	C25									24Vdc		06DA6606DBND132
06CC	A25	D2S0	208/230-3-60	33			160	160	120/240Vac	21.2	06DA6606DBNB330	
	B25								24Vac		06DA6606DBNC330	
	C25								24Vdc		06DA6606DBND330	
06CC	A25	G2S0	460-3-60	16.5			80	80	120/240Vac	10.6	06DA6606DBNB165	
	B25								24Vac		06DA6606DBNC165	
	C25								24Vdc		06DA6606DBND165	
06CC	A28	J2S0	12.8	7.5			575-3-60	16.7	79	120/240Vac	10.2	06DA6606DBNB167
	B28									24Vac		06DA6606DBNC167
	C28									24Vdc		06DA6606DBND167
06CC	A28	D2S0			208/230-3-60	41.6	108	108	120/240Vac	26.7	06DA6606DBNB416	
	B28								24Vac		06DA6606DBNC416	
	C28								24Vdc		06DA6606DBND416	
06CC	A28	G2S0			460-3-60	20.9	90	90	120/240Vac	13.4	06DA6606DBNB209	
	B28								24Vac		06DA6606DBNC209	
	C28								24Vdc		06DA6606DBND209	
06CC	A37	J2S0			16.5	10	575-3-60	18.8	91	120/240Vac	12.1	06DA6606DBNB188
	B37									24Vac		06DA6606DBNC188
	C37									24Vdc		06DA6606DBND188
06CC	A37	D2S0	208/230-3-60	46.5			228	228	120/240Vac	29.8	06DA6606DBNB298	
	B37								24Vac		06DA6606DBNC298	
	C37								24Vdc		06DA6606DBND298	
06CC	A37	G2S0	460-3-60	23.3			114	114	120/240Vac	14.9	06DA6606DBNB233	
	B37								24Vac		06DA6606DBNC233	
	C37								24Vdc		06DA6606DBND233	

NOTE:

1. Rated Load Amp (RLA) values shown are for the factory-installed overloads. Compressors protected by devices other than the factory-installed overloads must be determined from the Must Trip value of the device.

06CC 50-99 cfm Overcurrent Protection

Fixed speed 06CC 50-99 cfm compressors must be applied with properly sized overload relays or calibrated circuit breakers to protect the motor against overcurrent fault conditions. These devices will protect the compressor against running overcurrent, locked rotor, and primary and secondary single phasing.

Some fixed speed 06CC 50-99 cfm models may be configured with a part winding start to reduce inrush current at startup. Carlyle recommends a 1.0 to 1.25 second time delay between energizing the first and second windings.

Variable speed 06CC 50-99 cfm compressors may use the overcurrent protection features of the variable speed drive, provided that the drive is listed with UL for this purpose. The overcurrent setting of the drive must be consistent with the maximum continuous current (MCC) value as defined in the 06CC 50-99 cfm Electrical Data section on page 16.

Overcurrent protection for all 06CC 50-99 cfm compressors must be manually reset.

Wiring diagrams for the 06CC 50-99 cfm compressor are shown in Fig. 15. The different wiring configurations are obtained with different jumper bars and insulators. Figure 16 shows how these items should be installed on the compressor terminal plate. Jam nut no. 1 is factory installed and should never be in direct contact with the ring terminal. The insulator, ring terminals, and remaining jam nuts must be installed per the installation instructions or there is a risk of damage to the insulation within the terminal plate assembly.

06CC 50-99 cfm compressors applied with variable speed drives should follow the wiring diagrams in Fig. 17.

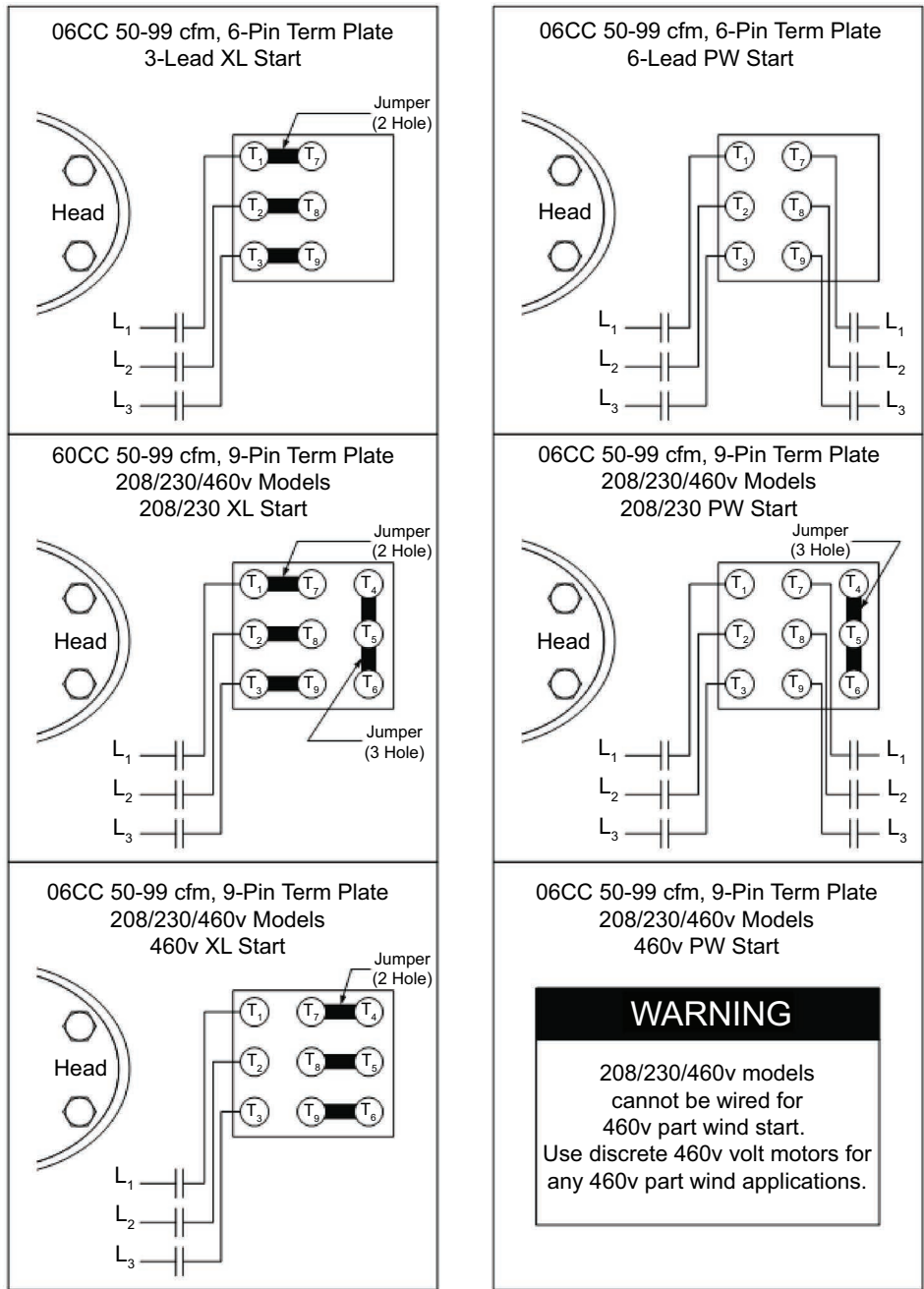
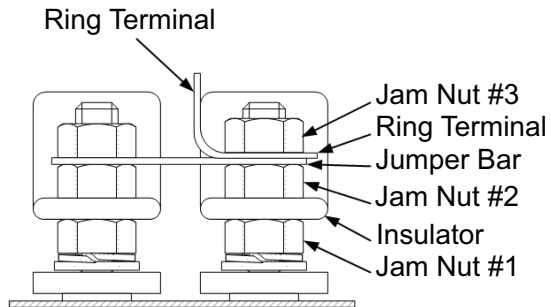

Fig. 15 — 06CC 50-99 cfm Fixed Speed Wiring Diagrams



06CC 50-99 cfm Terminal Pin Wiring
Detailed View

Fig. 16 — 06CC 50-99 cfm Terminal Pin Layout

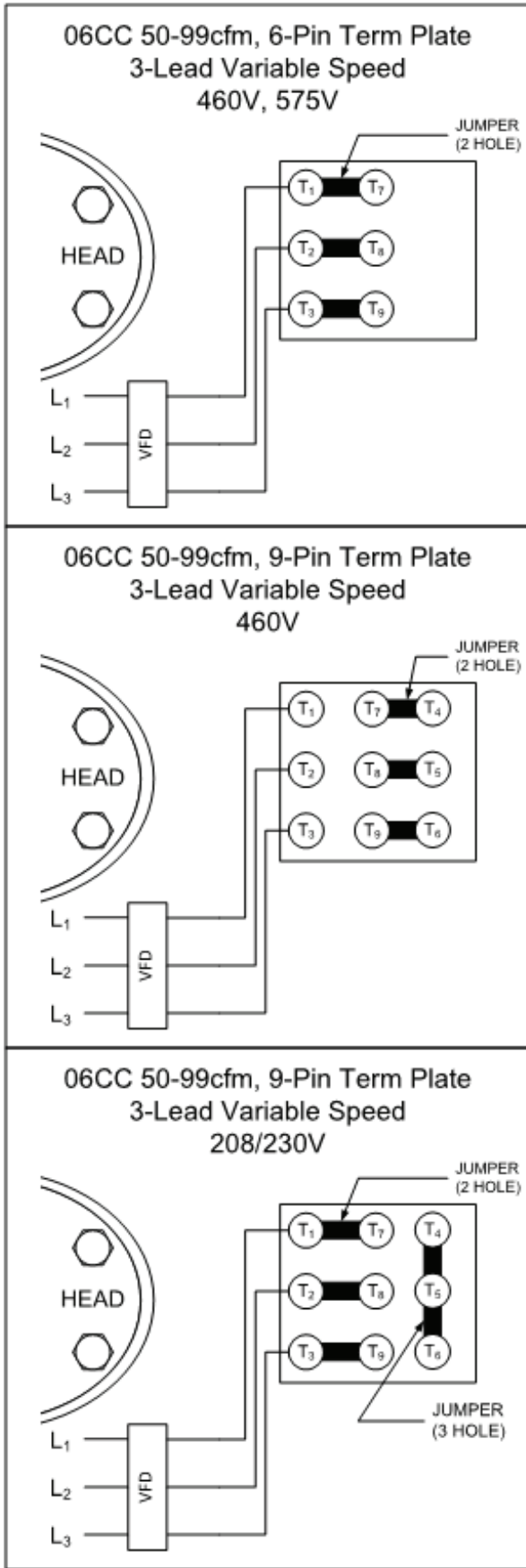

Fig. 17 — 06CC 50-99 cfm Variable Speed Wiring Diagrams

06CC 50-99 cfm Electrical Data

Table 5 provides locked rotor current for across the line starting and MCC ratings for the 06E compressors. MCC rating is a limitation of the compressor that is independent of both the refrigerant and application range. The 06CC 50-99 cfm compressors are not provided with factory-installed overloads. The calculation of the Rated Load Amps (RLA) for the 06E compressors will depend on the device that provides this protection for the compressor.

RLA FOR FIXED SPEED 06CC 50-99 CFM WITH OVERLOAD RELAY

Rated Load Amps (RLA) is based on the trip setting of the overload relay. This trip setting must be set per the manufacturer’s instructions and may not exceed the MCC listed for the compressor. The system designer may elect to use a lower trip value, but doing so may impact the overall operating range of the compressor. This can reduce the cost of the electrical system in cases where the full range of the compressor is not required for the system’s intended application. In this type of control system, the RLA for the compressor is:

$$RLA = \frac{\text{Trip Setting}}{1.4} \left. \vphantom{\frac{\text{Trip Setting}}{1.4}} \right\} \text{For 06CC 50-99 cfm with Overload Relay}$$

RLA FOR FIXED SPEED 06CC 50-99 CFM WITH CALIBRATED CIRCUIT BREAKER

With calibrated circuit breakers, the RLA is based on the Must Trip Amps (MTA) rating of the breaker. This MTA value may not exceed the MCC listed for the compressor. The system designer may elect to use a circuit breaker with a lower MTA rating, but doing so may impact the overall operating range of the compressor. This can reduce the cost of the electrical system in cases where the full range of the compressor is not required for the system’s intended application. In this type of control system, the RLA for the compressor is:

$$RLA = \frac{\text{MTA}}{1.4} \left. \vphantom{\frac{\text{MTA}}{1.4}} \right\} \text{For 06CC 50-99 cfm with Circuit Breakers}$$

Table 5 — 06CC 50-99 cfm Electrical Data

COMPRESSOR MODEL			COMPRESSOR ELECTRICAL DATA						OVERCURRENT PROTECTION DEVICES								
			MAX KW	NOMINAL HP	VOLTS	MAXIMUM CONTINUOUS CURRENT	LOCKED ROTOR AMPS		OVERLOAD RELAY			Calibrated Circuit Breaker					
							ACROSS THE LINE	PART WINDING START ^{1 5}	PART NUMBER	RATED LOAD AMPS ²	MAXIMUM DIAL SETTING	PART NUMBER	RING TERM. KIT REQUIRED ³	MUST HOLD AMPS	MUST TRIP AMPS	LOCKED ROTOR AMPS	RATED LOAD AMPS ^{4 5}
06CC550	J	2S0	22.0	15	575-3-60	27	98	59	06EA907185	19.3	24	HH83XB438	Yes	23	27	86	19.3
					HH83XB689	No	23	27	86	19.3							
	F				460-3-60	32	142	85	06EA907185	22.9	28	HH83XB414	Yes	27	32	145	22.9
					HH83XB698	No	27	32	145	22.9							
	E				280/230-3-60	68	283	170	06EA907186	48.6	60	HH83XB455	Yes	59	68	245	48.6
					HH83XB697	No	59	68	245	48.6							
460-3-60	32	142	85	06EA907185	22.9	28	HH83XB414	Yes	27	32	145	22.9					
HH83XB698	No	27	32	145	22.9												
06CC665	J	2S0	25.3	20	575-3-60	38	120	72	06EA907185	27.1	33	HH83XA461	No	33	38	124	27.1
					No alternate circuit breaker available												
	F				460-3-60	50	173	104	06EA907186	35.7	44	HH83XB437	Yes	43	50	176	35.7
					HH83XB606	No	43	49	173	35							
	E				280/230-3-60	100	345	207	06EA907186	71.4	89	HH83XB376	Yes	73	85	333	60.7
					No alternate circuit breaker available												
460-3-60	50	173	104	06EA907186	35.7	44	HH83XB437	Yes	43	50	176	35.7					
HH83XB606	No	43	49	173	35.0												
06CC675	J	2S0	25.3	20	575-3-60	38	120	72	06EA907185	27.1	33	HH83XA461	No	33	38	124	27.1
					No alternate circuit breaker available												
	F				460-3-60	50	173	104	06EA907186	35.7	44	HH83XB437	Yes	43	50	176	35.7
					HH83XB606	No	43	49	173	35.0							
	E				280/230-3-60	100	345	207	06EA907186	71.4	89	HH83XB378	Yes	77	89	365	63.6
					No alternate circuit breaker available												
460-3-60	50	173	104	06EA907186	35.7	44	HH83XB437	Yes	43	50	176	35.7					
HH83XB606	No	43	49	173	35.0												
06CC899	J	2S0	39.1	30	575-3-60	58	176	106	06EA907186	41.4	51	HH83XA430	No	50	58	168	41.4
					HH83XA469	No	46	53	164	37.9							
	F				460-3-60	73	253	152	06EA907186	52.1	65	HH83XB432	Yes	63	73	240	52.1
					HH83XB604	No	63	73	240	52.1							
	E				280/230-3-60	113	506	304	06EA907187	80.7	125	HH83XC406	No	122	141	464	100.7
					No alternate circuit breaker available												
460-3-60	73	253	152	06EA907186	52.1	65	HH83XB432	Yes	63	73	240	52.1					
HH83XB604	No	63	73	240	52.1												

NOTES:

1. Locked Rotor Amps (LRA) for the second winding start are 1/2 of the across the line LRA.
2. Rated Load Amps (RLA) shown for the overload relay are based on the maximum allowed dial setting shown in the table. Lower dial settings will allow for lower RLA values but with a more restricted compressor operating range.
3. These circuit breakers require the use of ring terminal kit 06EA660125.
4. RLA shown for the circuit breakers are based on the Must Trip Amp (MTA) value of the breaker.
5. Compressor protected by devices other than the factory-installed overloads must be determined from the MTA value of the device.

RLA for Variable Speed 06CC Compressors

In variable speed applications, the variable speed drives provide the overcurrent protection for the compressor. The variable speed drive must have the appropriate code agency listings for this purpose. The factory-installed overloads on the 06CC 17-37 cfm compressors must be removed or compressor models purchased without these.

The current trip setting must be set per the drive manufacturer's instructions and may not exceed the MCC listed for the compressor. The system designer may elect to use a lower trip value (and thus smaller drive), but doing so may impact the overall operating range of the compressor. This can reduce the cost of the drive in cases where the full range of the compressor is not required for the system's intended application. In this type of control system, the RLA for the compressor is:

$$RLA = \frac{\text{VFD Trip Setting}}{1.4} \left. \vphantom{\frac{\text{VFD Trip Setting}}{1.4}} \right\} \text{ For Variable Speed 06CC}$$

COMPRESSOR ACCESSORIES

Variable Speed Drives

Variable frequency drives must not be selected based upon the nominal horsepower of the motor. The variable speed drive must be carefully selected based on the maximum expected current draw of the compressor and the rating factors used by the drive manufacturer.

Internal Pressure Relief Valves

All 06CC 50-99 cfm compressors utilize internal pressure relief valves to comply with agency safety requirements. One of these pressure relief valves is located on the low-stage valve plate and relieves pressure from the intermediate-stage to the low-stage in the event of an over-pressure condition. The second relief valve is located in the body of the compressor, underneath the center head valve plate, and is intended to relieve pressure from the high-stage to the intermediate pressure stage.

Operational problems that result in the compressor operating at elevated head pressures (for example, cycling on the high-pressure switch) may also cause the relief valve to subsequently open at lower operating pressures and thus require replacement.

Internal pressure relief valves are not required in compressors with displacements less than 50 cfm. The 06CC 17-37 cfm compressors do not contain internal pressure relief valves.

Suction Inlet Strainer

Each 06CC compressor is equipped with a suction strainer located in the suction manifold.

Discharge Mufflers and Baffle Plates

Mufflers can reduce discharge gas pulsation and effectively eliminate vibration problems downstream. They should be

placed as close to the compressor as possible to maximize efficiency and minimize vibration.

Mufflers should be installed per the supplier's direction but are generally able to be mounted in either horizontal or vertical piping runs. When mounted horizontally, care should be taken to ensure that oil does not accumulate within the muffler housing.

Baffle plates may also be used to attenuate discharge gas pulsations. Baffle plates will have higher pressure drops than mufflers for similar levels of performance, but baffle plates can be more easily retrofitted into existing systems. Wherever possible, Carlyle recommends the use of mufflers over baffle plates. Consult the Service Guide, Lit no. 020-611, for guidelines on the selection and use of baffle plates.

Crankcase Heaters

Carlyle requires the use of crankcase heaters in any application that has access to electrical power when the compressors are not running. The heater should be energized only when the compressor is not operating. The heater is inserted into a blind hole in the bottom cover plate in all 06CC compressors. These heaters should use thermal grease to enhance heat transfer and be constrained such that they do not move out of position during the operation of the compressors.

Cylinder Head Cooling Fans

Cylinder head cooling fans are recommended for all applications except R-404A. These fans are effective at desuperheating the interstage gas, which can reduce or eliminate the need for supplementary liquid injection. Applications where the compressor is located in an airstream with a consistent velocity of 8 to 10 fps (~3 m/s) do not require cylinder head fans.

Liquid Injection

Liquid injection is required for some applications to control discharged gas temperatures. The valves are designed to operate only when the suction gas from the subcooler cannot absorb enough heat to control the compressor's leaving discharge gas temperatures between 200°F and 230°F (93.3°C and 110°C). If a desuperheating valve is required, the sensing bulb must be attached to the discharge line approximately 6 in. (150 cm) from the discharge service valve. A normally closed solenoid valve must be installed upstream of the desuperheating valve and controlled to open only when the compressor is operating. The outlet of the desuperheating valve should be connected directly to the flange at the motor end cover of the compressor. See Fig. 8 and 9 for details.

Compressor Mounts

The 06CC compressors may use either rigid mounts or spring mounts. Variable speed applications using spring mounts should be carefully evaluated to ensure that there are no resonances across the entire speed range.

Compressor Service Valves

Recommendations for suction and discharge service valves for fixed speed applications can be found in Table 6. For variable speed applications, Carlyle recommends choosing the largest valve, standard or alternate, that is identified for the compressor model.

Table 6 — Service Values

MODEL NUMBER	SUCTION SERVICE VALVE				DISCHARGE SERVICE VALVE			
	RECOMMENDED		ALTERNATE		RECOMMENDED		ALTERNATE	
06CC*17	1-3/8" ODF	06DA660065	1-5/8" ODF	06EA660090	7/8" ODF	06DA660062	1-1/8" ODF	06DA660064
06CC*25			1-1/8" ODF	06DA660063				
06CC*28								
06CC*37	1-5/8" ODF	06EA660090	1-3/8" ODF	06DA660065 06DA660063	1-1/8" ODF	06DA660064	7/8" ODF	06DA660062
06CC550			No Alternate					
06CC665								
06CC675								
06CC899								
All Models Installed in PWM Applications	1-5/8" ODF	06EA660090	1-1/8" ODF 1-3/8" ODF	06DA660063 06DA660065	1-3/8" ODF	06DA660065	1-5/8" ODF	06EA660090

* 06CC*17 models, 5th digit (A, B, or C)

06CC*25 models, 5th digit (D, E, or F)

06CC*28 models, 5th digit (G, H, or J)

06CC*37 models, 5th digit (K, L, or M)

