

SERVICE GUIDE

06D/06E/06CC
COMPRESSORS



Carlyle®

WHAT THIS GUIDE CAN DO FOR YOU

Carlyle Compressor Company provides this guide to aid the service specialist in proper installation, service, and maintenance of 06D, E, CC compressors. Following the procedures in this guide will extend the life of the system and improve performance.

This guide uses the terms DANGER, WARNING and CAUTION. These terms have specific meanings that identify the degree of hazard. Typically in the HVAC industry, these specific meanings are:

DANGER

There is an immediate hazard which **WILL** result in severe personal injury or death.

WARNING

Hazards or unsafe practices which **COULD** result in severe personal injury or death.

CAUTION

Potential hazards or unsafe practices which **COULD** result in minor personal injury or equipment damage

HOW TO USE THIS GUIDE

This book is divided into four major sections (see Table of Contents):

SECTION 1.0 - General Compressor and Customer Information

SECTION 2.0 - Start-Up, Troubleshooting, and Service

SECTION 3.0 - Compressor Parts Data

SECTION 4.0 - Electrical Data

An Index is provided in the back of this guide.

TO GET MORE HELP

Carlyle Compressor Company sells compressors to Carrier for use in their packaged units and to OEMs (Original Equipment Manufacturers) that design and build finished systems. The system manufacturer is the expert on the system, including the application of our compressor. All questions, on either the packaged system or the compressor in that system, should be first directed to the local Carrier distributor (for Carrier systems) or the OEM or its local representative (for other units). If this support, along with this service guide, cannot resolve your compressor problem, please contact our Carlyle engineering group.

CARLYLE COMPRESSOR THANKS YOU FOR SELECTING OUR EQUIPMENT

Manufacturer reserves the right to discontinue, or change at any time, specifications or designs and prices without notice and without incurring obligations.

CARLYLE COMPRESSOR DIVISION • © CARRIER CORPORATION
P.O. Box 4808 • Syracuse, New York 13221
In the USA: 1-800-GO-CARLYLE (1-800-462-2759)
In Canada (WWG Totaline): 1-800-6687905
In Mexico (Totaline): 01 800 171 11 11

CONTENTS

1.0 GENERAL COMPRESSOR AND CUSTOMER INFORMATION

1.1	Compressor Model Number Significance	3
1.2	Nameplate Significance.....	6
1.3	Compressor Serial Number Significance	8
1.4	Carlyle OEM Compressor Warranty	9
1.5	Service Billing and Credit	9
1.6	Carlyle Service Replacement Compressors, Parts, and Support..	10

2.0 START-UP, TROUBLESHOOTING, AND SERVICE

2.1	Technical Assistance - Carlyle OEM Compressors	10
2.2	Recommended Start-Up Procedure	11
2.3	Troubleshooting Procedure	20
2.4	Service Procedures	32
2.5	Connection Points — 06D, 06E, and 06CC Compressors	44
2.6	Cross-Sectional View — 06D Semi-Hermetic Compressor	54
2.7	Cross-Sectional View — 06E Semi-Hermetic Compressor.....	55
2.8	Exploded View — 6-Cylinder 06D Compressor	56
2.9	Exploded View — 6-Cylinder 06E Compressor	58
2.10	Torque Guide — 06D and 06CC (16 to 37 Cfm) Compressors...	60
2.11	Torque Guide — 06E and 06CC (50 to 99 Cfm) Compressors ...	61

3.0 COMPRESSOR AND PARTS DATA

3.1	06D Series Compressors — Physical Data	62
3.2	06E Series Compressors — Physical Data.....	64
3.3	06CC Series Compressors — Physical Data.....	66
3.4	06D, E High Efficiency (H.E.) Compressors	68
3.5	Compressor Bodies Without Oil	68
3.6	Refrigerants and Oils for 06D, E, CC Compressors.....	69
3.7	Oil Viscosity and Pour Points	71
3.8	Oil Additives	72
3.9	Oil Pressure	72
3.10	High Flow Oil Pump (Bearing Head).....	73
3.11	Replacement Oil Pump/Pump End Bearing Package.....	73
3.12	Oil Pressure Safety Switch	74
3.13	06CC, E Discharge Gas Cylinder Head Temperature Sensor and 06E Pressure Relief Valve.....	85
3.14	06D, E Cylinder Head Cooling Fans	86
3.15	Capacity Control Accessory Packages	87
3.16	Capacity Control Coil Packages (06D, E).....	89
3.17	Crankcase Heater Data	90
3.18	Compressor Mounting Data	91
3.19	Compressor Service Valves (06D, E, CC)	91

3.20	Service Valve Gaskets (06D, E, CC)	91
3.21	Oil Drain Plug Adapter.....	92
3.22	Sight Glass Adapters for Oil Equalization	92
3.23	Replacement Sight Glass/Installation Tool	92
3.24	Replacement Motor End Mounting Foot.....	92
3.25	Gaskets — Cylinder Head and Valve Plate.....	93
3.26	Miscellaneous	94
3.27	Valve Plate Packages, Service Replacement.....	95
3.28	Muffler Recommendations	96
3.29	Electrical Accessories.....	97
3.30	Baffle Plate Recommendations	98
3.31	Interstage Pressure Tables (06CC Compressors Only)	98
4.0 ELECTRICAL DATA		
4.1	06DR 3 Phase Electrical Specifications	102
4.2	06DM, DA 3 Phase Electrical Specifications	104
4.3	06DR, DM Single Phase Electrical Specifications	106
4.4	06ER, EY 3 Phase Electrical Specifications	107
4.5	06EM, EZ 3 Phase Electrical Specifications.....	109
4.6	06EA, ET 3 Phase Electrical Specifications	111
4.7	06CC (16 to 37 Cfm) 3 Phase Electrical Specifications	113
4.8	06CC (50 to 99 Cfm) 3 Phase Electrical Specifications	115
4.9	06D Electromechanical Overcurrent Protection.....	116
4.10	06D and 06CC (16-37 Cfm) Electronic Overcurrent Protection	117
4.11	Electrical Hook-Up.....	130
4.12	Voltage and Current Unbalance	135
5.0 COMPRESSOR SERVICE WORKSHEETS		
	06D, 06E COMPRESSOR SERVICE WORKSHEET	137
	06CC COMPRESSOR SERVICE WORKSHEET	138
6.0 SMART UNLOADING & PWM VALVE		
6.1	Functional Overview	139
6.2	Identification	140
6.3	Smart Controller Inputs/Outputs	141
6.4	Smart Controller Configuration.....	146
6.5	Service Table.....	152
6.6	Compressor Protection and Control	153
6.7	PWM Valve.....	154
SERVICE GUIDE INDEX.....		161

06E COMPRESSORS

06ER 3 99 3 0 A - (RP)**

Model = 0, Package = 1 or 9, A = Shipped Without Oil

Design Variable:

New Compressors

- 0 = OEM Model
- 1 = Carrier A/C Model
- 2 = Old Design Refrigeration Valve Plates
- 6 = Carrier A/C Model
- 9 = Cemak Model
- S = Oil Sensor Block and OPSS Sensor

Service Compressors

- 2 = New Manufactured (A/C)
- 4 = Remanufactured (Low Temp.)
- 6 = Remanufactured (A/C)
- 7 = Remanufactured (Med Temp.)

Electrical Characteristics (XL and PW Start, Unless Noted):

- 0 = 208/230-3-60
- 1 = 575-3-60
- 3 = 208/230/460-3-50/60 (460v XL Only)
- 4 = 200-3-60
- 5 = 230-3-60
- 6 = 400/460-3-50/60
- 8 = 230-3-50
- 9 = 220/380-3-60

Displacement (in Cfm at 1750 rpm)

Design Configuration

- 0, 1, 2 = Models With Oil
- 3, 4, 5 = Models Without Oil
- 7 = 1 Unloader, Suction Cut-off, Oil-less (ER, EM Only)
- 8 = Special Order
- Y = SMART Unloading Model

Compressor Type:

STD* REV†

06EA	06EF	Compressor - A/C Duty	No Unloading	} Hot Gas Bypass Unloading
06EB	06EJ	Compressor - A/C Duty	1-Step Elec.	
06EC	06EK	Compressor - A/C Duty	2-Step Elec.	
06ED	06EL	Compressor - A/C Duty	1-Step Press.	} Suction Cut-Off Unloading
06EE	06EN	Compressor - A/C Duty	2-Step Press.	
06E2	06E6	Compressor - A/C Duty	1-Step Elec.	
06E3	06E7	Compressor - A/C Duty	2-Step Elec.	} Suction Cut-Off Unloading
06E4	06E8	Compressor - A/C Duty	1-Step Press.	
06E5	06E9	Compressor - A/C Duty	2-Step Press.	
06EM	-	Compressor - Refrig. Duty	Med Temp.	
06ER	-	Compressor - Refrig. Duty	Low Temp.	
06ET	-	Serv. Compressor A/C Duty Replaces 06E2,3,4,5,6,7,8, and 9.		
06EX	-	Compressor has 1 stage of suction cut-off unloading.		
06EY	-	Serv. Compressor A/C Duty Replaces 06EA,B,C,D,E,F,J,K,L, and N.		
06EZ	-	Compressor has 1 stage of Bypass unloading.		
	-	Serv. Compressor Refrig. Duty Replaces 06ER		
	-	Serv. Compressor Refrig. Duty Replaces 06EM		

* Standard Center Cylinder Head.

† Reversed Center Cylinder Head.

Service compressors shipped with reverse center head have the letter "R" after the serial number on the shipping box.

**Refrigeration Partner.

Information in shaded area is no longer available in standard factory production.

06CC COMPRESSORS

Design Variable:

- 101 = Single Pack, W/O Valves, with Oil
- 102 = Single Pack with Valves & Oil
- 103 = Single Pack, Service W/O Valves and Term. Box or Oil
- 201 = Single Pack, W/O Valves or Oil
- 202 = Single Pack with Valves
- S = Oil Sensor Block and OPSS sensor (shown as the 10th digit)

Electrical Characteristics:

- A = 415-3-50, XL and PW
- B = 415-3-50, XL
- C = 415-3-50, PW
- D = 208/230-3-60, XL
- E = 208/230/400/460-3-50/60
- F = 400/460-3-50/60, XL and PW
- G = 400/460-3-50/60, XL
- H = 400/460-3-50/60, PW
- J = 575-3-60, XL and PW
- K = 230-3-60, PW
- L = 220-3-50, XL and PW
- M = 220-3-50, XL
- N = 220-3-50, PW
- P = 220/346/380-3-50/60, XL and PW
- Q = 380-3-60, XL

Displacement(in Cfm at 1750 rpm) (See Note below)

Motor Size and Protection:

5th Digit	Motor Size	Overload Variable
0	15 FT-LB / 5 HP	Electromechanical Overcurrent Protection (*No Longer Available)
A	15 FT-LB / 5 HP	115/240V Control Voltage, Electronic Overcurrent Protection
B	15 FT-LB / 5 HP	24V AC Control Voltage, Electronic Overcurrent Protection
C	15 FT-LB / 5 HP	24V DC Control Voltage, Electronic Overcurrent Protection
1	20 FT-LB / 6.5 HP	Electromechanical Overcurrent Protection (*No Longer Available)
D	20 FT-LB / 6.5 HP	115/240V Control Voltage, Electronic Overcurrent Protection
E	20 FT-LB / 6.5 HP	24V AC Control Voltage, Electronic Overcurrent Protection
F	20 FT-LB / 6.5 HP	24V DC Control Voltage, Electronic Overcurrent Protection
2	24 FT-LB / 7.5 HP	Electromechanical Overcurrent Protection (*No Longer Available)
G	24 FT-LB / 7.5 HP	115/240V Control Voltage, Electronic Overcurrent Protection
H	24 FT-LB / 7.5 HP	24V AC Control Voltage, Electronic Overcurrent Protection
J	24 FT-LB / 7.5 HP	24V DC Control Voltage, Electronic Overcurrent Protection
3	24 FT-LB / 7.5 HP	Electromechanical Overcurrent Protection (*No Longer Available)
K	24 FT-LB / 7.5 HP	115/240V Control Voltage, Electronic Overcurrent Protection
L	24 FT-LB / 7.5 HP	24V AC Control Voltage, Electronic Overcurrent Protection
M	24 FT-LB / 7.5 HP	24V DC Control Voltage, Electronic Overcurrent Protection
4	45 FT-LB / 15 HP	Not Factory Installed, External Overcurrent Protection Required
6	60 FT-LB / 20 HP	Not Factory Installed, External Overcurrent Protection Required
7	75 FT-LB / 25 HP	Not Factory Installed, External Overcurrent Protection Required
8	90 FT-LB / 30 HP	Not Factory Installed, External Overcurrent Protection Required

Compressor Type:

- 06CC = Compound Cooling Model
- 06CY = Service Compressor
- 06C8 = Compressor, Special

Information in shaded area is no longer available in standard factory production.

NOTE: USE OF "Cfm" AS MODEL SIZE DESIGNATION

Carlyle uses the "Cfm" designation in the model number to identify the compressor size. The Cfm values are the sixth and seventh digits of the model number. See example above. Carlyle offers two series of compressors based on body size.

The smaller compressors, from 8 to 37 Cfm, are referred to as "D" size units (model number "06D"). The larger compressors, from 50 to 99 Cfm, are referred to as "E" size units (model number "06E").

The 06CC, or Compound Cooling compressors, are made in 16 to 37 Cfm and 50 to 99 Cfm sizes.

The 16 to 37 Cfm compressors use "D" size bodies. The 50 to 99 Cfm compressors use "E" size bodies.

NOTE: METRIC MEASUREMENTS

The compressors are built using English units: inches, foot-pounds, pints, etc. A corresponding metric measurement has been added to all the English units in this guide. These metric measures are a guide only, having been rounded to the nearest whole number, and therefore are not meant to be an exact mathematical conversion.

1.2 — Nameplate Significance

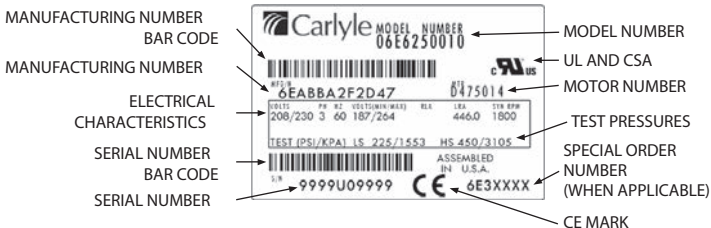

Explanation of the above items, starting clockwise from upper right:

MODEL NUMBER - Used when selecting and ordering a new compressor. Distributors use the model number to obtain a proper service replacement.

NOTE: Model numbers on some compressors are identified by the symbol “M/N” located in the upper right hand corner of the nameplate.

UL AND CSA - Single mark indicates that this compressor meets all the requirements for both UL (Underwriters Laboratory) and CSA (Canadian Standards Association). All 60 Hz semi-hermetic Carlyle Compressors are UL and CSA recognized and comply with UL, CSA, and NEC (National Electrical Code) requirements for internal motor protection.

MOTOR NUMBER - For Carlyle internal use only.

TEST PRESSURES - Each Carlyle 06D,E,CC compressor is pressure tested at our factory. The “LS” pressures are for the low side of the compressor. The “HS” pressures are for the high side of the compressors.

SPECIAL ORDER NUMBER (WHEN APPLICABLE) - For Carlyle internal use only.

CE MARK - This CE Mark indicates this compressor complies with the European CE Mark requirements.

SERIAL NUMBER - The unique number given to each compressor. This number, along with the model number and special order number, is normally all that is needed to obtain information about or order a service replacement compressor.

SERIAL NUMBER BAR CODE - For Carlyle internal use only.

ELECTRICAL CHARACTERISTICS - Are shown for all semi-hermetic compressors. Voltages are shown with respective operating ranges for both 50 and 60 cycle operation. Electrical phase and LRA (Locked Rotor Amps) information is also provided.

MANUFACTURING NUMBER - For Carlyle internal use only.

MANUFACTURING NUMBER BAR CODE - For Carlyle internal use only.

1.3 — Compressor Serial Number Significance

ALL NEW COMPRESSORS

Example: S/N 3695J00123

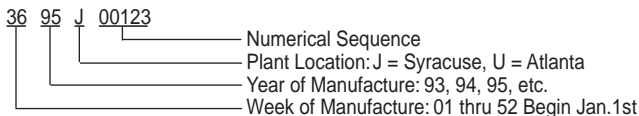

ALL SERVICE COMPRESSORS

Example: S/N 3602UD0123

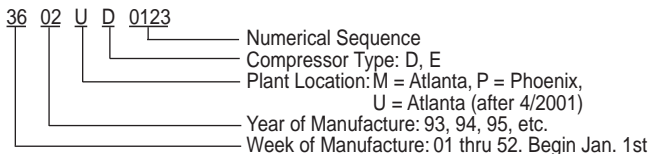

NEW AND SERVICE REPLACEMENT COMPRESSORS BUILT BETWEEN NOV. 1968 - OCT. 1978

Example: A2J0001

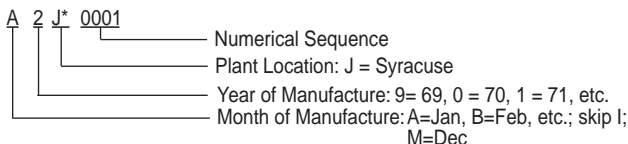

*An "X", "A" or "P" in this location indicates service compressor.

1.4 — Carlyle OEM Compressor Warranty

Original OEM compressors are warranted to be free from defects in material and workmanship for a period of 12 months from the date of original installation, or 20 months from the date of manufacture, whichever comes first. Terms and conditions of the compressor warranty are specified in the list price pages.

When a service compressor is used to replace an original compressor, the remaining portion of the first-year OEM warranty is transferred to the service compressor (within the United States and Canada).

Equipment may carry an extended OEM warranty if that warranty has been purchased from the OEM. The OEM issues the extended warranty, not Carlyle or its distributors, and the OEM is responsible for providing the end user with the credit.

If returning a compressor:

- place all parts back into compressor
- seal all compressor openings (oil leakage may create an environmental hazard)

NOTE: Opening a compressor for observation or determination of failure does not void warranty.

1.5 — Service Billing and Credit

Returns of in-warranty parts should be made to the same Local Carlyle Distributor who supplies these replacement parts.

Local Carlyle Distributors will sell parts and service compressors only to credit-approved accounts (except for cash sales).

1.6 — Carlyle Service Replacement Compressors, Parts, and Support

Carlyle service replacement compressors, parts, and support are available through a wide distribution network. **Technical support is provided by your local distributor.** Customer Service Representatives can provide assistance in locating your nearest distributor.

In the USA, contact your nearest Carlyle distributor.

Locate your distributor at www.Totaline.com or by calling Carlyle at 800-Go-Carlyle (800-462-2759)

In Canada, contact your nearest WWG Totaline branch location.

Locate your branch at <http://wwgtotaline.ca/en/branch/>, or by calling (800) 668-7905.

In Mexico, contact your nearest Totaline branch location.

Locate your branch at <https://www.totaline.com.mx/pages/Sucursales.html>, or by calling 01 800 171 11 11.

2.0 — START-UP, TROUBLESHOOTING, AND SERVICE

2.1 — Technical Assistance - Carlyle OEM Compressors

Carlyle Compressor Division sells compressors to OEMs (Original Equipment Manufacturers) that design and build the finished system. The OEM is the expert on the entire system, including the Carlyle compressor. All system or compressor questions should be directed first to the OEM or the OEM's local representative. If questions cannot be answered by the OEM or this Service Guide, please contact the Carlyle engineering group.

The following recommended start-up procedure for Carlyle 06D, 06E, and 06CC compressors will help eliminate initial

compressor failures caused by flooded start, floodback, and running out of oil.

The Troubleshooting Procedures section (Section 2.3, pages 20 to 31) will help pinpoint compressor and system problems.

The Service Procedures section (Section 2.4, pages 32 to 43) covers the replacement of valve plates and gaskets, service to the bearing head assembly containing the oil pump, and a clean-up procedure to follow in case of motor burnout. Most other internal service requires replacement of the compressor.

2.2 — Recommended Start-Up Procedure

Reliability data of Carlyle's 06D, 06E, and 06CC refrigeration compressors indicate that at least half of compressor failures occur during the first two to four months of operation. Many of these failures occur during the initial start-up of the unit. In other cases, troubled start-ups lead to compressor damage severe enough to cause premature failures. The major causes of failures of these compressors are flooded start, floodback, and running out of oil. Most of these failures can be avoided by using more care during the initial start-up of the compressors. Therefore, the following start-up procedure for 06D, 06E and 06CC compressors is provided.

BEFORE START-UP

1. Verify that the compressor nameplate indicates proper model and voltage. Do the values agree with system needs and available power?
2. Verify that there is oil in the system.

Since different refrigerants (CFC, HCFC or HFC) require specific oils (mineral, alkylbenzene, or polyolester [POE]), Carlyle ships most new and service compressors without oil.

The oil level for 06CC size 16 to 37 Cfm compressors and all 06D compressors should be at 1/4 to 3/4 of the sight glass. The oil level for 06CC size 50 to 99 Cfm compressors and all 06E compressors should be at 1/8 to 3/8 of the sight glass. **See Section 3.6, pages 69 to 71 for the proper Carlyle approved oils for the selected refrigerant. Oil should be added through the recommended oil fill connection ports on the compressor as identified in the figures in Section 2.5.**

Once the compressor system has been running for at least 24 hours, the most accurate oil levels are observed when the compressor is off. Oil levels in the sight glass can be affected by the rotation of the running gear.

OPERATING OIL LEVELS

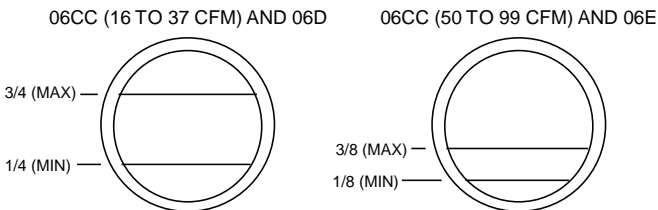

CAUTION

Do not add excess oil. It is especially important on the 06E and 06CC (50 to 99 Cfm) compressors that excess oil not be added to the system. Laboratory tests and field experience indicate excessive oil levels can cause blown valve plate and cylinder head gaskets, increase compressor operating temperatures, and cause oil equalization problems.

NOTE: All 06D compressors and 06CC (16 to 37 Cfm) compressors have one sight glass on the side of the crankcase. All 06E compressors and 06CC (50 to 99 Cfm) compressors have two sight glasses, on the oil pump end of the compressor.

Parallel compressor applications typically use an oil-control float system consisting of individual floats, a separator and an oil reservoir. When using a float system, do not interconnect the floats with an “equalization system” without approval from Carlyle application engineering. The use of a float “equalization system” can result in system oil control problems.

An oil equalization line can be used instead of a float system, except with 06CC compressors. The equalization line and the compressors must be level, and the line diameter must be large enough to allow both the refrigerant and oil to equalize between all the interconnected compressors. If the line is not level, it is undersized, or the system contains too much oil, the oil level will rise filling the line, and oil control between compressors will be lost. Typically, equalization lines are 1-1/8 in. (28 mm) in diameter or larger. For 06D compressors, a sight glass in the line is required to determine the system oil level.

Parallel systems using three (3) or more 06E compressors **require** the use of a common motor barrel interconnection line between compressors. Use of an interconnection line is **strongly recommended** on two (2) 06E compressor unit configurations. This system prevents oil from building up in an 06E motor barrel during the off cycle, thereby preventing an oil slug on start-up. The line is either 1/4 in. (6 mm) or 3/8 in. (8 mm) tubing inter-connecting to fitting located in the bottom of the 06E crankcases. To connect the 06E compressor

motor barrel, fitting P/N 5F20-1311 (5/8 in. -18 x 1/4 in. NPT) with AU51YA011 gasket is recommended. Some 50 Cfm compressors have a 1/4 in. NPT connection and do not require the 5F20-1311 fitting. The motor barrel interconnection line is in addition to either the crankcase oil equalization line or the oil floats.

Never interconnect the motor barrels of 06CC compressors, as the oil sump of these compressors are at intermediate pressure.

 **CAUTION**

06E compressors will not tolerate excessive oil charges.

Laboratory tests and field experience confirm that excess oil, especially in 06E compressors, can cause cylinder head gaskets and valve plates to fail, increase compressor operating temperatures, and lead to oil control problems. Page 12 notes the correct oil levels.

 **CAUTION**

Do not charge oil through the suction line or through the compressor suction access fittings. See the compressor figures in Section 2.5 for the location of the recommended oil charging ports. Adding oil into the suction side of the compressor can result in oil intake directly into the cylinders resulting in suction/discharge valve, piston and/or connecting rod damage.

Use only Carlyle approved oil appropriate for the refrigerant being used. Section 3.6 on pages 69 to 71 lists all the approved oils. Section 3.9 on page 72 notes the correct oil pump pressure in relation to age of the compressor.

3. Leak test, evacuate, and dehydrate the system.
4. Charge the system. When initially charging the high side of the system with liquid refrigerant, all service valves should be closed (front seated). This will prevent refrigerant from migrating to the compressor crankcase and into the oil, causing a flooded start.

The system is now charged and ready for start-up.

Recheck the oil levels and add or remove oil as necessary. Open (backseat) the discharge service valve and any oil equalization lines on parallel systems. Open the suction service valve 1/2 to 1 turn, or enough to allow the compressor to run without tripping the low-pressure switch in order to prevent damage to the compressor from any liquid refrigerant floodback.

5. On water-cooled condensing systems, open water supply valve and allow water to reach condenser. On air-cooled condensing systems, turn condenser fan on when the compressor unit is started.
6. Ensure that all evaporator connections are opened and fans started.
7. On systems with more than one compressor in parallel, start one compressor at a time.

COMPRESSOR START-UP

1. After circuit breaker and control circuit switches are placed in the ON position and the compressor starts, listen for unusual sounds. If unusual sounds are heard, shut down the compressor, investigate the cause, and correct. Possible problems are:
 - Excessive vibration
 - Excessive oil
 - Liquid slugging
 - Low oil

2. After the compressor has run 10 to 15 minutes and no liquid floodback is evident, completely open suction service valve. The other compressors within the system should be started in the same manner.
3. To ensure operating oil levels are within acceptable limits, closely observe the oil level in the compressors until the system has stabilized. During operation all refrigeration systems will lose some compressor oil to the system because:
 - All systems have a film of oil on the inside surface of the piping. At start-up, the lines are dry and the oil which coats the lines comes from the compressor crankcase.
 - Oil also traps in the low refrigerant velocity area of the system and must be made up by adding oil to the system. On systems with hot gas defrost, inspect the compressor for excessive oil after the defrost cycle has been completed.

The oil lost to the system must be replaced, but make sure not to add too much. The 06E and 06CC (50 to 90 Cfm) compressors have been successfully started in supermarket refrigeration configurations by adding only 1 quart (liter) of additional oil per compressor. The amount to be added will vary depending on the system, but keeping the oil level between 1/8 and 3/8 level in the sight glass will eliminate the chance of excessive oil charges.

 **CAUTION**

Adding excessive oil to the 06E and 06CC (50 to 99 Cfm) compressors can cause blown gasket problems.

When CFC or HCFC refrigerants are used with mineral or alkylbenzene oils, foam in the sight glass normally indicates either that there is serious liquid refrigerant floodback or that the running gear is hitting the oil due to a very high oil level. Very high oil levels are caused by either too much oil or excessive liquid refrigerant in the crankcase. HFC refrigerants and POE oils do not foam easily, so there will be less indication in the sight glass of either liquid refrigerant floodback or too much oil in the system.

 **CAUTION**

Liquid refrigerant should never be allowed to flood back to the compressor. It may wash out bearings and damage gas-kets. If liquid floodback is occurring, adjust the expansion valve or make other adjustments as necessary to eliminate this condition.

NOTE: One possible cause of flooding is improper control of the defrost cycle. Ensure defrost cycles are staggered so no more than one third of the system is on defrost at any time.

COMPRESSOR OPERATING LIMITS

Figures 1 and 2 show the components and typical operating ranges of the Carlyle 06D, E, and 06CC compressors.

RETURN GAS TEMP. (RGT) FOR
MEDIUM TEMP. AND DUTY
65°F (18°C) MAXIMUM.
PREFERRED RGT FOR LOW TEMP. DUTY
35°F TO 50°F (2°C TO 10°C)

MAX. TEMP AT DISCHARGE IS
275°F, 6" (135°C, 150mm) FROM
SERVICE VALVE, 250°F (120°C)
PREFERRED WITH POE OILS

SUCTION VALVE
LOCATION

BEARING HEAD
(PUMP END-PE)

CRANKCASE AT OIL SUMP.
100°F TO 130°F (38° TO 54°C)
MEASURE BELOW OIL LEVEL
ON CRANKCASE. MAXIMUM
ALLOWABLE TEMP.:165°F (74°C)

SIGHT GLASS
("D" LOCATION SHOWN)
OPERATING OIL LEVEL
RECOMMENDATIONS:
"D" COMPRESSORS -
1/4 TO 3/4 GLASS
"E" COMPRESSORS -
1/8 TO 3/8 GLASS
NOTE: SIGHT GLASS OF ALL 06E
COMPRESSORS LOCATED ON
PE FACE OF COMPRESSOR.



FACTORY INSTALLED OIL PRESSURE
SENSOR BLOCK FOR AVAILABLE OIL
PRESSURE SAFETY SWITCH (OPSS).
FOR MORE INFORMATION SEE SECTION 3.12.

Fig. 1 — Typical 06D, E Operating Limits

SUCTION VALVE LOCATION
MAXIMUM PREFERRED RGT
IS 35°F TO 50°F (2°C TO 10°C)

1/4" NPT OIL PUMP
PRESSURE CONNECTION
SEE PAGE 72 SECTION 3.9

OIL LEVEL SIGHT GLASS FOR 06CC (16 TO 37 Cfm)-
1/4 TO 3/4 SIGHT GLASS (SIGHT GLASS FOR "D" SIZE
[16 TO 37 Cfm] IS ON THE SIDE OF THE COMPRESSOR
BODY) FOR 06CC (50 TO 99 Cfm) - 1/8 TO 3/8 SIGHT GLASS

CRANKCASE OIL SUMP
100°F TO 130°F (38°C TO 54°C)
MEASURE BELOW CRANKCASE
OIL LEVEL, MAXIMUM
ALLOWABLE 165°F (74°C)

DISCHARGE VALVE LOCATION
MAXIMUM TEMP. AT
DISCHARGE IS 250°F, 6° (120°C,
150mm) FROM SERVICE VALVE



FACTORY INSTALLED OIL PRESSURE
SENSOR BLOCK FOR AVAILABLE OIL
PRESSURE SAFETY SWITCH (OPSS).
FOR MORE INFORMATION SEE SECTION 3.12.

Fig. 2 — Typical 06CC Operating Limits

2.3 — Troubleshooting Procedure

DANGER

Before attempting service work on the compressor, the following safety precautions must be strictly observed. Failure to follow these instructions could result in serious personal injury or death. See warning label.

Follow recognized safety practices and wear protective goggles.

Do not operate compressor or provide electric power to this unit unless the compressor terminal box cover is in place and secured.

Do not provide power to unit or turn on compressor unless suction and discharge service valves are open. When not operating keep at least one service valve open unless replacing the compressor.

Do not remove the compressor terminal box cover until all electrical sources have been disconnected.

DANGER

When leak-testing semi-hermetic compressors, check around the terminal box **cover**. Test around the wire entry point(s) of the **cover** because refrigerant is likely to concentrate there. **Do not remove the terminal cover to perform this leak testing because bodily injury or death can result from fire and/or explosion if cover is removed or unsecured before power is disconnected and pressure is relieved. Electrical terminal pins may blow out, causing injury and fire.**

COMPRESSOR ISOLATION

If you have determined there is no refrigerant leak around the terminals and the compressor must be replaced, proceed beginning with Step 1:

1. Shut off suction and discharge service valves to isolate compressor and slowly remove all refrigerant in compressor. Appropriate service practices should be followed to properly reclaim refrigerant removed from the compressor.
2. Disconnect all electrical wiring to compressor.
3. Unbolt suction and discharge service valves from compressor.

REMINDER: These valves may be sealing off refrigerant from the rest of the system. Do not open these valves without first determining whether there is refrigerant in the system.

Troubleshooting Guide - 06D, 06E and 06CC Compressors

OBSERVATION	POSSIBLE CAUSE	REMEDY
1. Compressor will not start	Power off	Check main switch, fuses and wiring
	Overcurrent protection open	Reset manually
	Oil safety switch open	Reset manually
	Loose electrical connections or faulty wiring	Tighten connections. Check wiring and rewire if necessary.
	Compressor motor burned out	Inspect and replace compressor if defective.
	2. Low compressor capacity or inability to pull down system	Broken connecting rods or pistons
For 06CC only: Blown valve plate or cylinder head gasket		See No. 3
Leaky valve plates or worn valve seats		Replace valve plate assembly
Leaky or broken suction valves		Pump down, remove cylinder head, examine valves and valve seats. Replace if necessary.
Check pressure difference between suction, interstage and discharge if:		a. Check for problems in low stage heads b. Check for problems in high stage head
a. pressure is low between suction and interstage b. pressure is low between interstage and discharge		

OBSERVATION	POSSIBLE CAUSE	REMEDY
<p>3. Blown valve plate or cylinder head gaskets</p>	<p>Cylinder head bolts not properly torqued</p> <p>Excessive oil in 06E and 06CC (50 to 99 Cfm) compressors causes hydraulic cylinder pressures</p>	<p>a. Replace gaskets b. Retorque cylinder head bolts to: 06D and 06CC (16 to 37 Cfm): 30 to 35 ft-lb (40 to 48 Nm) 06E 100 06CC (50 to 99 Cfm): 90 to 35 ft-lb (122 to 136 Nm)</p> <p>a. Remove excessive oil until oil level maintained between 1/8 to 3/8 up the sight glass b. On multiple 06E compressor units, add motor barrel oil equalization line NOTE: Do not use a motor barrel oil equalization line with 06CC compressors</p>
<p>4. Compressor cycles intermittently</p>	<p>Liquid refrigerant floodback or flooded start</p> <p>Low-pressure switch erratic in operation</p> <p>Insufficient refrigerant in system</p> <p>Suction service valve closed</p> <p>Insufficient water flowing through condenser or clogged condenser</p> <p>Discharge service valve not fully open</p> <p>Air in system</p>	<p>See No. 7 (Flooding)</p> <p>a. Check tubing to switch to see if clogged or crimped b. Verify proper setting of switch</p> <p>Add refrigerant</p> <p>Open valve</p> <p>a. Adjust water regulating valve to condenser b. Clean condenser</p> <p>Open valve</p> <p>Purge</p>

OBSERVATION	POSSIBLE CAUSE	REMEDY
5. Compressor continually cycles	Faulty pressurestats	Repair or replace
	Dirt or restriction in tubing to pressurestat	Check and clean tubing
	Condenser capacity reduced by refrigerant over-charge accompanied by high discharge pressure	Remove excess refrigerant
	Plugged filter-drier	Replace filter
6. Low discharge pressure	Excessive water flow through condenser	Adjust water regulating valve
	Suction service valve partially closed	Open the valve
	Leaky compressor suction valves	Pump down, remove the cylinder head, examine valves and valve seats. Replace if necessary
	Worn piston rings	Replace compressor
7. Flooding	Improper system piping allows liquid to compressor	Correct piping
	Defrost cycle improperly set or not operating correctly	Do not allow more than 1/3 of system on defrost at any time. Verify proper operation of defrost system
	Defective or improperly set expansion valve	Increase superheat or replace valve
	Evaporator fan failure	Correct problem or replace fan
8. Low suction pressure	Insufficient refrigerant in system	Add refrigerant
	Evaporator fan failure	Correct problem or replace fan

OBSERVATION	POSSIBLE CAUSE	REMEDY	
9. Compressor noisy	Slugging due to floodback of refrigerant	See No. 7 (Flooding)	
	Hydraulic knock due to excess oil in circulation	<ul style="list-style-type: none"> a. Remove excess oil b. Recheck oil return system and pipe sizes 	
	Bearings damaged because of loss of oil	<ul style="list-style-type: none"> a. Add oil (only after confirming all system oil has returned to the compressor) b. Check oil return system and piping size c. See No. 15 (Parallel Systems Oil Level) and No. 11 (Oil Pressure) d. Check for defective oil failure control 	
	Improper support or isolation of piping	Provide sufficient right angle bends in piping to absorb vibration and support firmly with suitable hangers	
	Compressor not firmly mounted	Check for loose mounts	
	Unit not properly isolated or vibration pad defective	Add vibration isolation or check for defective isolation pads	
	Broken connecting rods, valves or other running gear	Replace compressor	
	10. Pipe rattle	Inadequately supported piping or loose pipe connections	<ul style="list-style-type: none"> a. Support pipes and/or check pipe connections b. Add muffler or baffle plate
		Low oil charge	Verify oil level requirements
	11. Oil pressure lower than normal or no oil pressure	Faulty oil pump drive segment	Replace segment
Refrigerant floodback		See No. 7 (Flooding)	
Desuperheating TXV stuck open		Replace TXV	
Worn oil pump		Replace bearing head assembly	
Worn compressor bearings		Replace compressor	

OBSERVATION	POSSIBLE CAUSE	REMEDY
<p>12. Compressor motor protectors or discharge temperature sensor tripping or cycling</p>	High suction pressure on low temperature compressor causes excessive amp draw	If system does not have EPR valve, throttle suction service valve until system pulls down
	High discharge pressure	Check for loss of condenser water, blocked condenser fan or coil, or defective fan motor
	Incorrect overload relay or must trip amp setting too low	Replace with correct overload relay
	Detective overload relay or circuit breaker	Replace
	High suction temperature	Reduce suction temperature by TXV adjustment or provide desuperheating
	Loose power or control circuit wiring connection	Check all power and control circuit connections
	Defective motor	Check for motor ground or short. Replace compressor if found
	Faulty motor protection device	On all 06E and 06CC compressors, check the thermal sensor in the cylinder head. Replace head sensor if necessary
	High compression ratio (suction too low/condensing too high); return gas temperature above application limits	Adjust compressor operational envelope
	For 06CC compressors only: Broken valve on high stage or blown high stage gasket	Repair compressor
Insufficient desuperheating	Adjust desuperheating valve	

OBSERVATION	POSSIBLE CAUSE	REMEDY
13. Compressor cycles on locked rotor	Low line voltage	Measure line voltage and determine location of voltage drop
	Seized compressor (remove bearing head assembly and attempt to rotate crankshaft)	Replace compressor
	Compressor motor defective	Check for motor winding short or ground
	Single phasing	Measure voltage across all 3 legs at contactor. Correct source of problem
	Liquid refrigerant condensing in cylinder	Check and replace valve plates
	On part-winding start compressors, the second set of windings may not be energized	a. Faulty contactor – replace b. Faulty time-delay relay – replace
14. Motor Burnout	Inspect control box for welded starter contacts, welded overload contacts, or burned out heater elements	Replace defective components and compressor. Check refrigerant and oil for contamination and clean to prevent repeat failure
	Inspect failed compressor for worn bearings or motor compartment contamination	Replace compressor. Check refrigerant and oil for contamination and clean to prevent repeat failure

OBSERVATION	POSSIBLE CAUSE	REMEDY
<p>15. On parallel compressor installations, oil level does not equalize or remain at a constant level in all compressors</p>	<p>Oil equalization line not level, preventing gas equalization NOTE: Oil equalization lines cannot be used with 06CC compressors. A float system must be used</p> <p>06E Compressors Only: Pressure equalization check valve in the motor rotor lock bolt may have been left out in one or all compressors NOTE: Check valve not required with float system</p> <p>Excessive blow-by into crankcase - worn rings, valves or blown gasket</p> <p>Improper suction line sizing</p> <p>Oil reservoir check valve bad or wrong pressure</p> <p>With Float System: Oil is not equalized in sight glass</p>	<p>Level oil equalization line</p> <p>Remove suction service valve and look for check valve in motor rotor lock bolt at the end of the crankshaft. Check valve is required on all 06E compressors in systems using the oil equalization line connected at the sight glass location</p> <p>Replace gasket, valve plate, or compressor</p> <p>Resize lines</p> <p>Replace check valve; 20 psi check valve required</p> <p>a. Check floats. Replace detective floats b. Check for proper selections and settings: -060 and 06CC (f6 to 37 Cfm) - 1 /4 to 3/4 sight glass -06E and 06CC (50 to 90 Cfm) -1/8 to 3/8 sight glass c. If floats have equalization line, the line between the floats may have to be removed. Contact Carlyle engineering</p>

OBSERVATION	POSSIBLE CAUSE	REMEDY
16. Compressor running hot	Blown valve plate or cylinder head gasket	Blown valve plate or cylinder head gasket
	Broken suction or discharge valve	Broken suction or discharge valve
	Compression ratio too high	<ul style="list-style-type: none"> a. Verify proper setting of high and low pressure switches b. Inspect for condenser plugging c. Ensure all evaporator and condenser fans are operating properly
	High suction temperature	Reduce suction temperature by TXV adjustment or provide desuperheating
	Cylinder head cooling fan not operating or incorrect voltage for fan motor	Replace defective part or verify available voltage agrees with fan motor voltage
	06E and 06CC (50 to 99 Cfm) Compressors only: Non-seating internal pressure relief valve	Check for signs of overheating, replace if necessary
	High oil level	High oil level
	Excessive blow-by into crankcase - worn rings, valves or blown gasket	Replace gasket, valve plate, or compressor

OBSERVATION	POSSIBLE CAUSE	REMEDY
<p>17. Oil safety switch trip</p> <p>a. If sight glass appears empty</p> <p>b. If sight glass appears normal</p>	<p>Faulty switch or oil pressure settings</p> <p>NOTE: Never add oil to the system without first confirming that oil has been physically lost, not simply trapped in the system. Check oil levels after a defrost cycle</p>	<p>Manually check for oil pressure. If correct, check that switch is correct model and has proper settings (see page 75, Section 3.12)</p>
	<p>Oil trapped in the system</p> <p>NOTE: At times, the sight glass may appear empty when actually it is completely full</p>	<p>a. Check line sizing and risers for proper sizing to return oil</p> <p>b. If floats are being used, check for proper setting and proper functionality</p>
	<p>Liquid refrigerant in crankcase</p>	<p>a. Check for low superheats which can return refrigerant - raise superheat</p> <p>b. Check for liquid migration during OFF cycle - provide a form of pumpdown protection</p>
<p>For 06CC Compressors Only:</p> <p>18. High mid-stage pressure</p>	<p>Broken valve or blown gasket on the high stage</p>	<p>Replace broken valves or gasket</p>
<p>19. Low mid-stage pressure</p>	<p>Broken valve or blown gasket on the low stage</p>	<p>Replace broken valves or gasket</p>
<p>20. Economizer/Desuperheater connection hot</p>	<p>Broken valve on high stage</p>	<p>Replace broken valves</p>
	<p>Blown high stage gasket</p>	<p>Replace gasket</p>

OBSERVATION	POSSIBLE CAUSE	REMEDY
21. Intermediate pressure equals the discharge pressure	Center low stage valve plate gasket is blown (typically caused by heavy liquid floodback or flooded start)	Eliminate floodback and replace gasket
	Compressor started with discharge service valve closed	Open discharge service valve
	High stage valve plate is on the low stage cylinder head	Switch valve plates so high stage valve plate is on the high stage cylinder head
	Internal relief valve loose	Tighten internal relief valve
	Internal relief valve blown	Replace internal relief valve

LEGEND
EPR- Evaporator Pressure Regulator
TXV - Thermostatic Expansion Valve

2.4 — Service Procedures

The service section covers replacement of valve plates and gaskets, service to the bearing head assembly containing the oil pump, and a clean-up procedure to follow in case of motor burn out. Most other internal service requires replacement of the compressor.

REMOVE, INSPECT AND REPLACE CYLINDER HEAD AND VALVE PLATE ASSEMBLY

To test for leaking discharge valves or blown cylinder head or valve plate gaskets:

1. Pump compressor down.
2. Observe suction and discharge pressure equalization. If valves are leaking or a gasket is blown, the pressure will equalize rapidly.

Maximum allowable discharge pressure drop is 3 psi per minute after initial drop of 10 to 15 psi in first half minute.

New reed valves may require 24 to 48 hour run-in time to seat completely.

A compressor bank (head) with a blown gasket can also usually be detected by touch since the head temperature will normally be much hotter than a bank with good gaskets.

3. If there is an indication of loss of capacity and discharge valves are functioning properly, remove valve plate assembly and inspect suction valves.

NOTE: This test procedure is not applicable to compressors equipped with pressure actuated unloader valves due to rapid pressure equalization rate. Inspect suction and discharge valves by disassembling valve plate.

DISASSEMBLY

1. Disassemble cylinder heads by removing cylinder head bolts. Leave at least two bolts partially threaded to prevent any problems if refrigerant is accidentally left in the compressor under pressure. To separate the cylinder head from the valve plate, pry up between the head and valve plate. When the cylinder head is separated from the compressor body remove the last threaded bolts.

CAUTION

Do not hit the cylinder head to break it free of the valve plate. This may shear the valve plate dowel pins. Sheared dowel pins usually require the compressor to be replaced.

2. Inspect cylinder heads for warping, cracking, or damage to gasket surfaces. Replace if necessary.
3. After the cylinder head is off, the valve plate may be removed as follows:
 - a. Remove one valve stop cap screw and loosen the other.
 - b. Swivel valve stop to allow access to hole from which the cap screw was removed.
 - c. Re-insert cap screw and tighten to break valve plate away from compressor. (Jack screw method, see Fig. 3.) For 06E valve plates, pry against the raised tab to break valve plate away from the compressor.



**Fig. 3 — Disassembly of Valve Plate
(Standard Efficiency Valve Plate Shown)**

4. Pry up along sides of valve plate to remove valve plate from crankcase. This provides access to suction reed valves (see Fig. 4). Remove suction valves from dowel pins. On 06D and 06CC (16 to 37 Cfm) compressors, also remove the suction valve positioning springs (see Fig. 5).
5. Inspect components for wear or damage. If replacement is necessary, replace as a complete assembly. Individual parts must not be interchanged. Alignment of high efficiency discharge valves is critical for proper seating. See Section 3.25 to 3.27, pages 93 to 95, for applicable replacement valve plate packages.

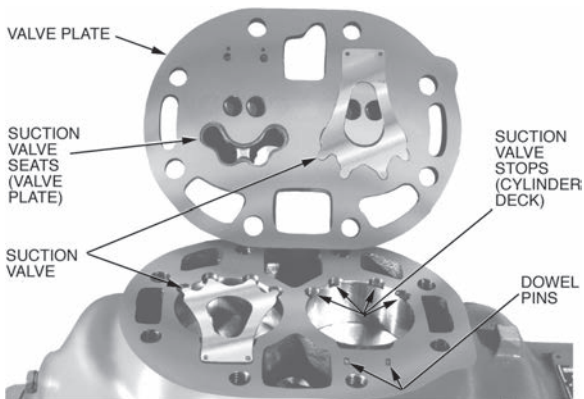

**Fig. 4 — Valve Plate Removed
(06E Refrigeration Valve Plate Shown)**

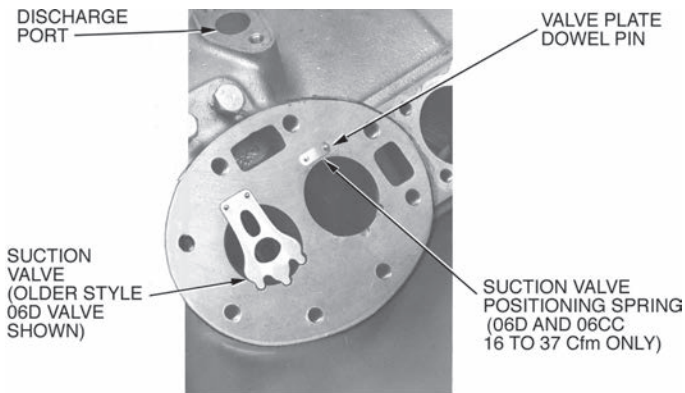

Fig. 5 — Suction Valve and Positioning Springs in Place (06D Shown)

REASSEMBLY

1. If reassembling existing components, do not interchange valves or turn them over. They must be reassembled in their original position. Install the suction valve positioning springs (06CC size 16 to 37 Cfm and 06D compressors only) on dowel pins. Assemble positioning springs with spring ends bearing against cylinder deck (Fig. 5), spring bow upward.
2. Install suction valve on dowel pins as follows:
 - a. 06D Compressors: Install suction valves on top of positioning springs as mentioned in Step 1 above.
 - b. 06E Compressors: If compressor uses a suction valve and a backer valve (looks like half a suction valve), backer valve must be installed before installing full size suction valve (Fig. 6).

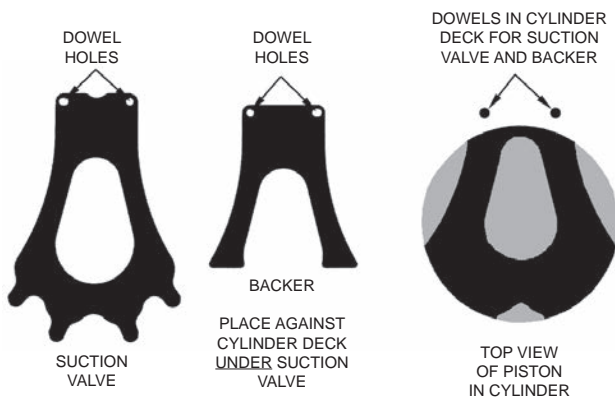

Fig. 6 — Piston, Suction Valve, and Backer Positions (06E)

3. Install new valve plate gasket. Using proper hold-down torque will prevent leaks.
 - a. Fiber gaskets can be installed dry or lightly oiled. Do not soak gaskets in oil. If an oil-soaked gasket is overheated, it will bind to the metal, making the valve plate and/or the head difficult to remove.
 - b. Metal gaskets must be installed dry.
4. Place valve plate on cylinder deck.
5. Install cylinder head gasket.

NOTE: The center cylinder heads and unloader side heads use different gaskets from the plain side head. To confirm the gasket is correct, place it over the cylinder head and verify all exposed machined surfaces will be covered by the gasket.

- a. Line up the gasket with the cylinder head and valve plate.
 - b. 06E Compressor: Secure the center rib with a cap screw and washer and torque to 4 to 6 ft-lb (5 to 8 Nm).
6. Replace cylinder head. To prevent high to low side leak in center of cylinder head gasket, torque 06D cylinder head cap screws to 30 to 35 ft-lb (40 to 48 Nm), and 06E cylinder head cap screws to 90 to 100 ft-lb (122 to 136 Nm).

NOTE: Torque bolts in an alternating sequence pattern (top to bottom, left to right). Do not torque bolts in a circular pattern.

7. Certain high compression ratio applications develop high discharge gas temperatures which may cause the cylinder head and fiber valve plate gaskets to develop a set. Under these conditions the cap screws may lose hold-down torque. It is recommended that all gear cap

screws be re-torqued 24 hours after new fiber gaskets are installed.

NOTE: Compressors with metal core gaskets do not require re-torque.

REMOVE, INSPECT AND REPLACE BEARING HEAD ASSEMBLY

An oil pressure tap is located in the bearing head assembly used on all 06D refrigeration duty, newer 06D A/C duty, and all 06E refrigeration and A/C duty compressors (Fig. 7 and Fig. 8).

For 06D, E, CC oil pressure, see page 72, Section 3.9.

The oil pump assembly is contained in the pump end bearing head aluminum casting. The pump end main bearing is a machined part of this casting. No insert bearing is required.

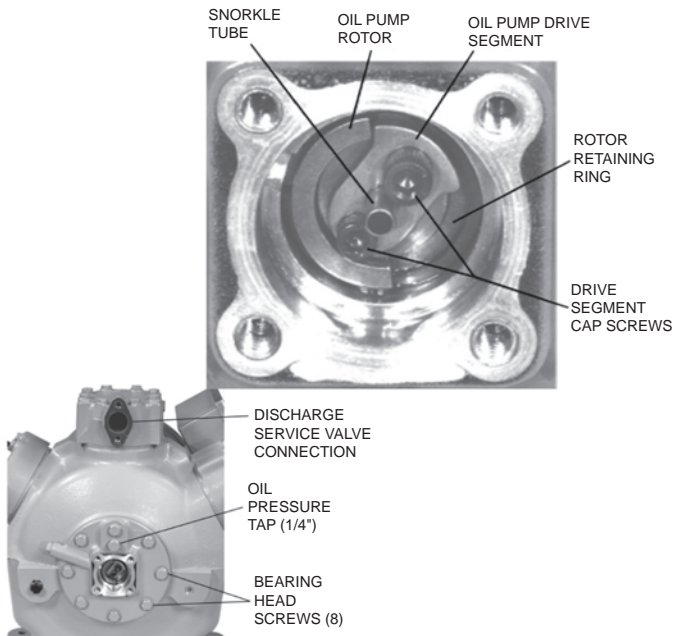

Fig. 7 — Removing Pump End Bearing Head (06D Compressor)

1. To disassemble, first remove four (4) cap screws from the bearing head cover plate and remove the oil feed guide vane and spring.
Remove the two (2) drive segment cap screws from the end of the crankshaft (see Fig. 7 and Fig. 8). **These screws must be removed before the bearing head can be removed.**
2. Remove the eight (8) cap screws holding the bearing head assembly to the crankcase. Remove the bearing head assembly by pulling forward.

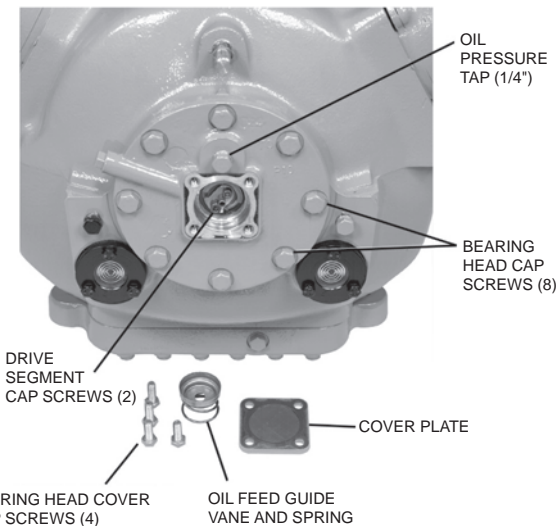

Fig. 8 — Removing Pump End Bearing Head (06E Compressor)

3. Inspect the bearing surfaces for evidence of wear or damage. If bearing surface is worn or scored, or if the oil pump is defective, the complete bearing head must be replaced (see replacement bearing head package listed below).

Compressor	Replacement Bearing Head Package
06CC, 16 to 37 Cfm, and all 06D	06DA660126
06CC, 50 to 99 Cfm, and all 06E	06EA660157

While bearing head is removed, inspect internal running gear for obvious problems (broken rods or pistons).

4. To reassemble, bolt the bearing head to the crankcase.
Bolt torque:
 - 06CC, 16 to 37 Cfm, and all 06D: 30 to 35 ft-lb (40 to 48 Nm)
 - 06CC, 50 to 99 Cfm, and all 06E: 50 to 60 ft-lb (75 to 81 Nm)
5. Bolt the drive segment (replace if worn) to the crankshaft. Bolt torque:
 - No. 10 Screw: 4 to 6 ft-lb (5 to 8 Nm)
 - 1.4 in. (6 mm) screw: 12 to 15 ft-lb (16 to 20 Nm)

IMPORTANT: The 1/4 in. snorkel tube should face away from the crankshaft (Fig. 7).

6. Insert the oil feed guide vane with the **large diameter inward**. Place the oil feed vane spring **over small diameter** of guide vane (**do not install spring before installing guide vane**). Install pump cover plate (bolt torque: 16 to 20 ft-lb or 22 to 27 Nm).

NOTE: Do not over-torque or aluminum threads in bearing head could be stripped.

MOTOR BURNOUT CLEAN-UP PROCEDURE

When a hermetic motor burns out, the stator winding decomposes and forms carbon, water, and acid, which contaminate refrigerant systems. These contaminants must be removed from the system to prevent repeat motor failures. See Carlyle/Carrier recommendation procedures for clean-up after burnout in semi-hermetic compressors literature #020-262.

 **WARNING**

Before attempting service work on the compressor, see safety precautions listed in Section 2.3 and on compressor terminal box cover. Also follow any installation instructions provided with the replacement compressor. **Failure to follow these instructions could result in equipment damage or serious personal injury.**

1. Determine cause of burnout and make necessary corrections.
 - a. Inspect control box for blown fuses, welded starter contacts, welded overload contacts or burned out heater elements.
 - b. Inspect compressor terminal plate for burned or damaged terminals and insulation, and shorted or grounded terminals.
 - c. Inspect unit wiring for loose power connections.
 - d. Check for power supply fluctuation beyond design limits (voltage too high or low). If power supply is a problem, provide the appropriate system protector.
2. Close compressor suction and discharge service valves and remove the refrigerant from the compressor using environmentally approved methods. Leave remaining refrigerant in system.
3. Remove damaged compressor and replace.
 - a. Remove suction and discharge shut-off valve bolts and all other connections to damaged compressor.
 - b. Remove damaged compressor and replace with a new compressor.
 - c. On severe motor burnouts, be sure shut-off valves and suction or discharge lines are not contaminated. If contaminated, thoroughly clean or replace before connecting replacement compressor.
4. Install new liquid line filter-drier. If the system has a suction line filter-drier, replace the core.

5. Evacuate and dehydrate replacement compressor. Ensure oil in compressor is at the proper level.

NOTE: Since most new and service compressors are now shipped without oil in the crankcase, you must check to see if there is oil. Adding or charging oil is usually easier prior to installing the compressor.

- If there is no oil, add the appropriate oil for the service. Oil charges are listed in Sections 3.1 to 3.3.
 - If there is oil, determine if it is compatible with the refrigerant. If the oil is not compatible, use the drain connection to remove the oil. Dispose of the removed oil following the appropriate environmental guidelines. Since the compressor has not been run, a thorough draining is all that is needed to remain within the limits of residual oil levels. There is no need to “flush” the compressor with the replacement oil. Once the oil is removed, add the appropriate oil (see above).
6. Place compressor in operation. After 2 to 4 hours of operation, inspect compressor oil for discoloration and/or acidity. If oil shows signs of contamination, replace oil and filter-driers and clean the suction strainer.

NOTE: When testing for moisture and acidity, be sure the test kit used is appropriate for the refrigerant (CFC, HCFC, or HFC) and the oil (mineral, alkylbenzene, or POE) in the system. Carrier’s Total Test Kit is accurate for CFC and HCFC air-conditioning applications. If used with POE oils, Total Test Kit will indicate acid, but is not an accurate indicator of moisture.
 7. Inspect oil daily for discoloration and acidity. If oil stays clean and acid-free, the system is clean. If oil shows signs of contamination, change oil, change filter-drier, and clean suction strainer. If filter-drier or suction strainer is dirty or discolored, repeat this step until system is cleaned.

2.5 — Connection Points, 06D, 06E, and 06CC Compressors

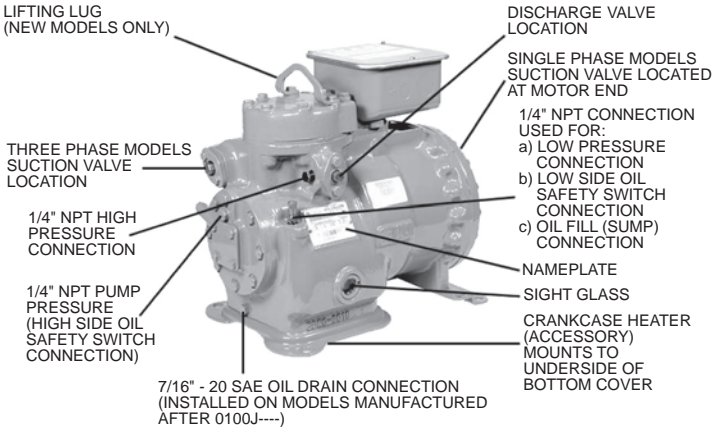

NOTE: Bolt sizes and thread pitch: Compressors are built using English unit bolts. The bolts have no exact metric equivalents. Therefore, to prevent possible cross-threading, loose bolts, or damage to threaded portions of the casing, comparable metric measurements are not included.

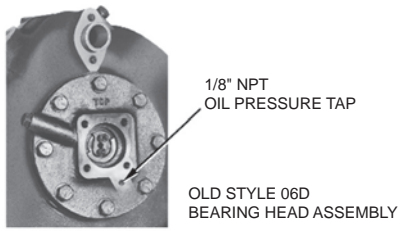
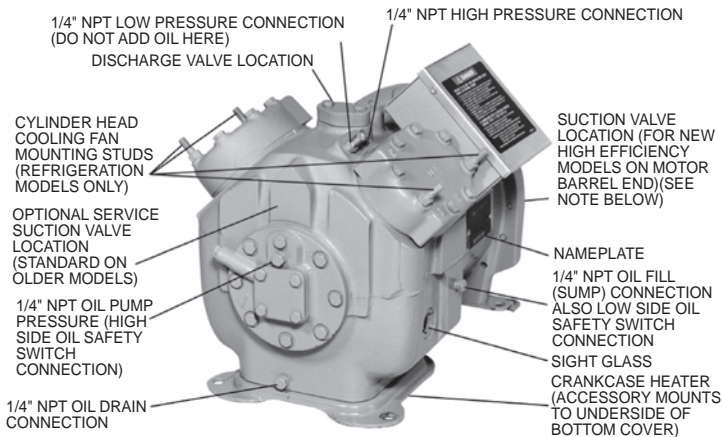

Fig. 9 — 06D 2-Cylinder Compressor Connection Points



NOTES:

1. **Bolt sizes and thread pitch:** Compressors are built using English unit bolts. The bolts have no exact metric equivalents. Therefore, to prevent possible cross-threading, loose bolts, or damage to threaded portions of the casing, comparable metric measurements are not included.
2. The 13 and 16 Cfm service compressors are made with dual suction ports.

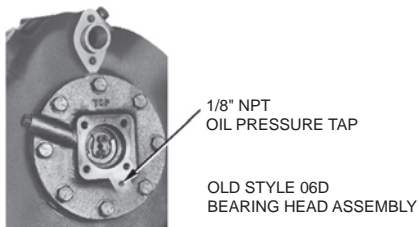
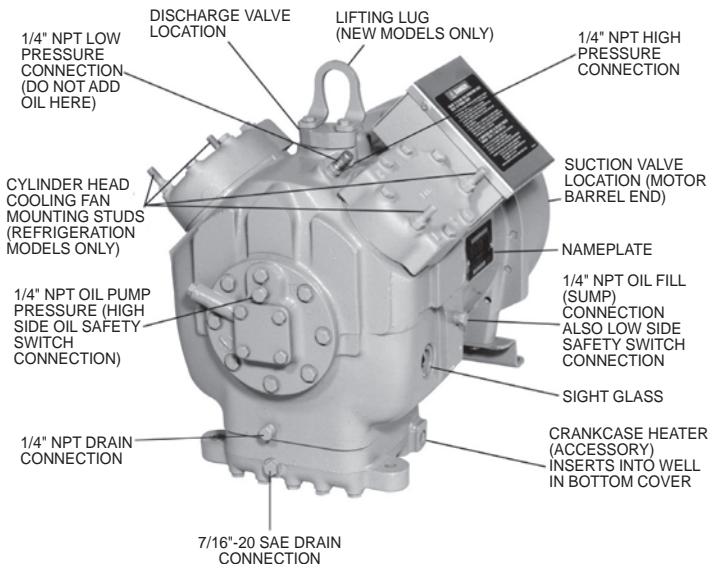

Fig. 10 — 06D 4-Cylinder Compressor (13 to 16 Cfm) Connection Points



NOTE: Bolt sizes and thread pitch: Compressors are built using English unit bolts. The bolts have no exact metric equivalents. Therefore, to prevent possible cross-threading, loose bolts, or damage to threaded portions of the casing, comparable metric measurements are not included.

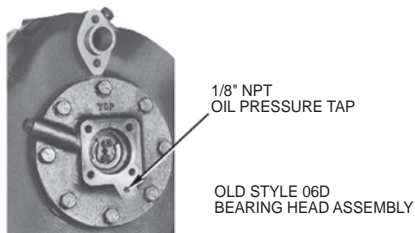
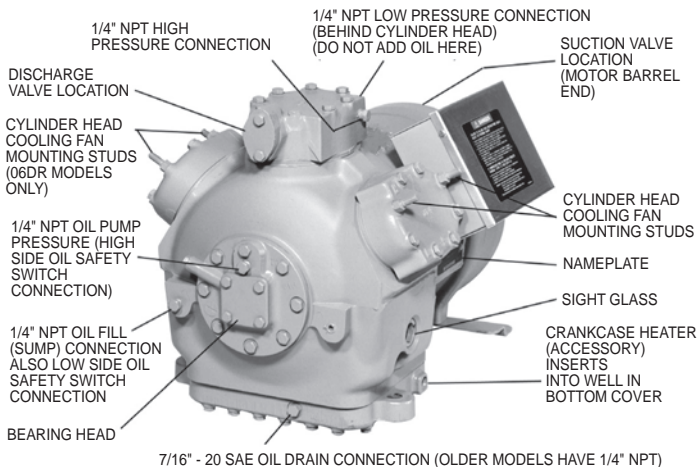

Fig. 11 — 06D 4-Cylinder Compressor (18 to 20 Cfm) Connection Points



NOTE: Bolt sizes and thread pitch: Compressors are built using English unit bolts. The bolts have no exact metric equivalents. Therefore, to prevent possible cross-threading, loose bolts, or damage to threaded portions of the casing, comparable metric measurements are not included.

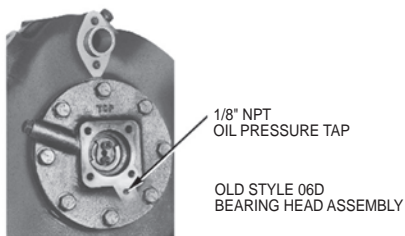
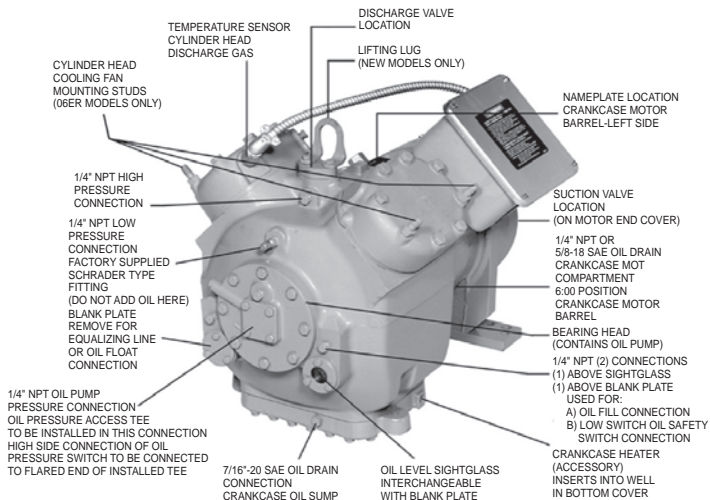
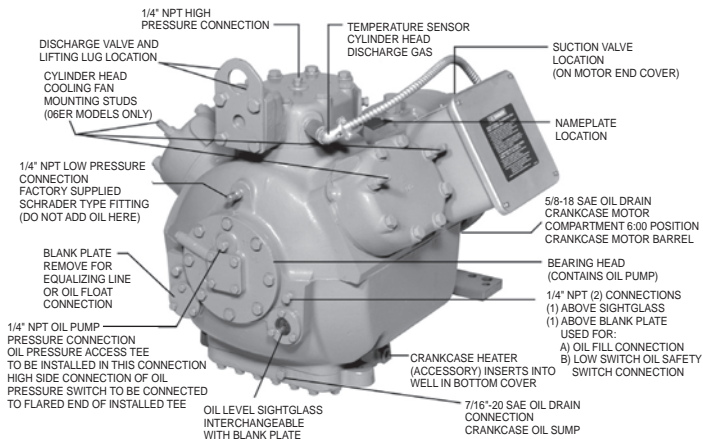

Fig. 12 — 06D 6-Cylinder Compressor (25, 28, 37, and 41 Cfm) Connection Points



NOTE: Bolt sizes and thread pitch: Compressors are built using English unit bolts. The bolts have no exact metric equivalents. Therefore, to prevent possible cross-threading, loose bolts, or damage to threaded portions of the casing, comparable metric measurements are not included.

Fig. 13 — 06E 4-Cylinder Compressor (50 and old 66 Cfm) Connection Points



NOTE: Bolt sizes and thread pitch: Compressors are built using English unit bolts. The bolts have no exact metric equivalents. Therefore, to prevent possible cross-threading, loose bolts, or damage to threaded portions of the casing, comparable metric measurements are not included.

**Fig. 14 — 06E 6-Cylinder Compressor (65, 75, 99 Cfm)
 Connection Points**

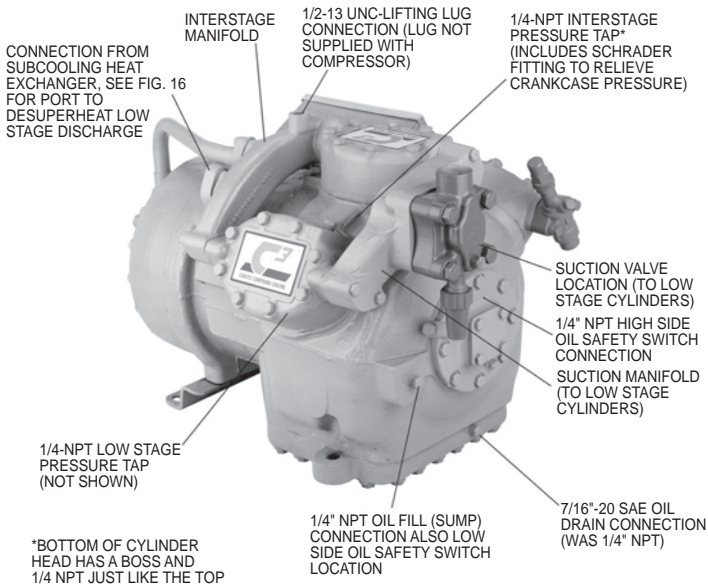

NOTE: Bolt sizes and thread pitch: Compressors are built using English unit bolts. The bolts have no exact metric equivalents. Therefore, to prevent possible cross-threading, loose bolts, or damage to threaded portions of the casing, comparable metric measurements are not included.

Fig. 15 — 06CC Compressor (16 to 37 Cfm), 06D Body Pump End Connection Points

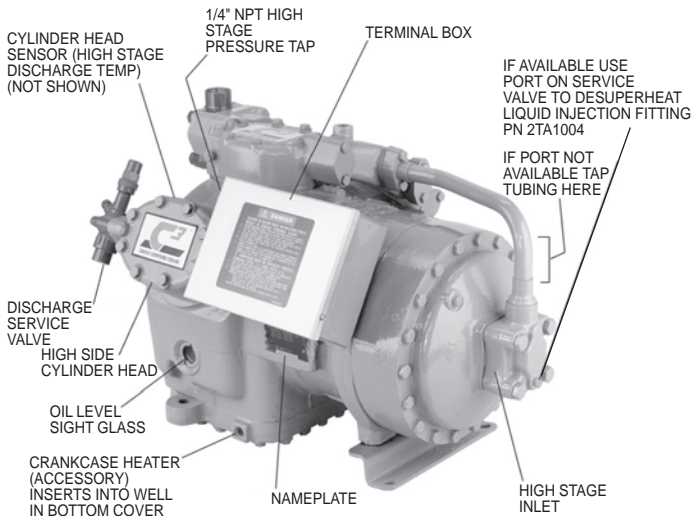

NOTE: Bolt sizes and thread pitch: Compressors are built using English unit bolts. The bolts have no exact metric equivalents. Therefore, to prevent possible cross-threading, loose bolts, or damage to threaded portions of the casing, comparable metric measurements are not included.

Fig. 16 — 06CC Compressor (16 to 37 Cfm), 06D Body Motor End Connection Points

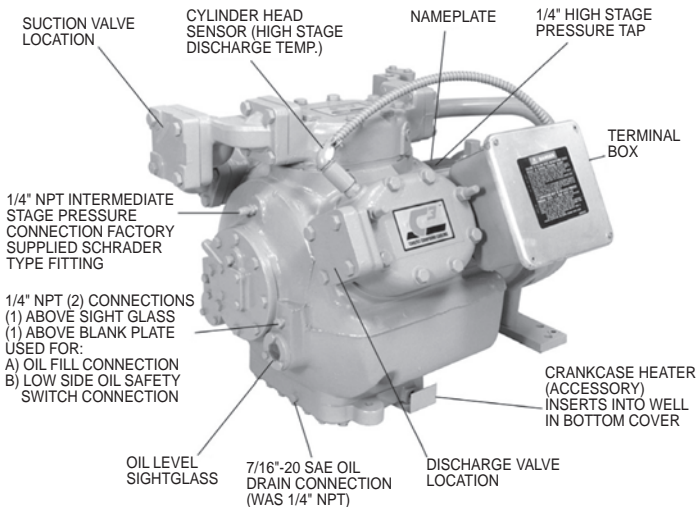

NOTE: Bolt sizes and thread pitch: Compressors are built using English unit bolts. The bolts have no exact metric equivalents. Therefore, to prevent possible cross-threading, loose bolts, or damage to threaded portions of the casing, comparable metric measurements are not included.

Fig. 17 — 06CC Compressor (50 to 99 Cfm), 06E Body Pump End Connection Points

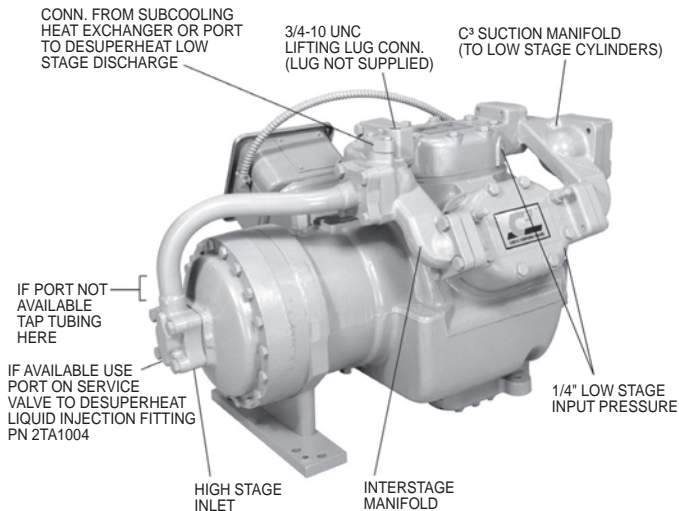

NOTE: Bolt sizes and thread pitch: Compressors are built using English unit bolts. The bolts have no exact metric equivalents. Therefore, to prevent possible cross-threading, loose bolts, or damage to threaded portions of the casing, comparable metric measurements are not included.

Fig. 18 — 06CC Compressor (50 to 99 Cfm), 06E Body Motor End Connection Points

2.7 — Cross-Sectional View, 06E Semi-Hermetic Compressor

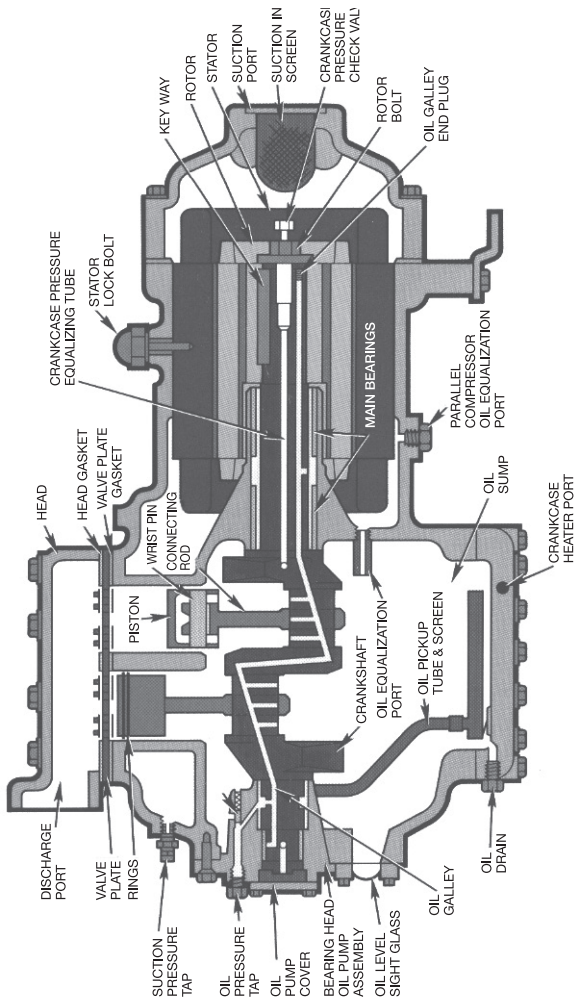

2.8 — Exploded View - 6-Cylinder 06D Compressor

Complete parts breakdown shown for reference only. Some parts may be pictured prior to design changes and not all parts are available as replacements.

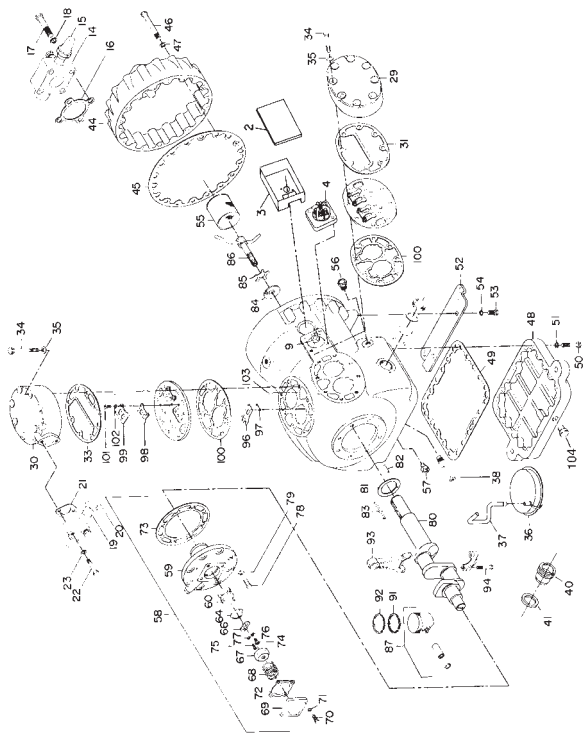

LEGEND

- 2 — Terminal Box Cover
- 3 — Terminal Box
- 4 — Terminal Plate Assembly
- 9 — Grommet (for power leads)
- 14 — Suction Service Valve
- 15 — Suction Service Valve
- 16 — Seal Cap
- 17 — Suction Service Valve
- 18 — Suction Service Valve
- 19 — Discharge Service Valve
- 20 — Discharge Service Valve
- 21 — Discharge Service Valve
- 22 — Discharge Service Valve
- 23 — Discharge Service Valve
- 29 — Standard Side Bank Cylinder Head

30	Center Bank Cylinder	—	—
31	Standard Side Bank Cylinder Head Gasket (Unloader Side Bank Head not shown)	—	—
33	Center Bank Cylinder Head Gasket	—	—
34	Cylinder Head Cap Screw	—	—
35	Cylinder Head Cap Screw Gasket	—	—
36	Oil Filter Screen Assembly	—	—
37	Oil Suction Tube	—	—
38	Oil Relief Valve Assembly	—	—
40	Oil Level Sight Glass Assembly	—	—
41	Oil Level Sight Glass Gasket	—	—
44	Motor End Cover	—	—
45	Motor End Cover Gasket	—	—
46	Motor End Cover Cap Screw	—	—
47	Motor End Cover Cap Screw Washer	—	—
48	Bottom Cover Plate	—	—
49	Bottom Plate Gasket	—	—
50	Bottom Plate Cap Screw	—	—
51	Bottom Plate Cap Screw Washer	—	—
52	Compressor Foot	—	—
53	Compressor Foot Screw	—	—
54	Compressor Foot Everlockwasher	—	—
55	Suction Strainer Assembly	—	—
56	Oil Bypass Plug	—	—
57	Oil Return Check Valve Assembly	—	—
58	Pump End Bearing Head Assembly	—	—
59	Bearing Head	—	—
60	Pump Rotor	—	—
64	Pump Rotor Retaining Ring	—	—
66	Drive Segment	—	—
67	Oil Feed Guide Vane	—	—
68	Oil Feed Vane Spring	—	—
69	Cover Plate	—	—
70	Cover Plate Cap Screw	—	—
71	Cover Plate Cap Screw Gasket	—	—
72	Cover Plate Gasket	—	—
73	Bearing Head Gasket	—	—
74	Cap Screws and Lockwashers	—	—
75	Cap Screws and Lockwashers	—	—
76	Cap Screws and Lockwashers	—	—
77	Cap Screws and Lockwashers	—	—
78	Bearing Head Cap Screw	—	—
79	Bearing Head Cap Screw Washer	—	—
80	Crankshaft	—	—
81	Thrust Washer	—	—
82	Spiral Pin	—	—
83	Rotor Drive Key	—	—
84	Rotor Washer	—	—
85	Rotor Lockwasher	—	—
86	Equalizer Tube Assembly	—	—
87	Piston Assembly	—	—
91	Oil Ring (Not All Models)	—	—
92	Compression Ring	—	—
93	Connecting Rod and Cap Assembly	—	—
94	Connecting Rod Cap Screw	—	—
96	Suction Valve	—	—
97	Suction Valve Positioning Spring	—	—
98	Discharge Valve	—	—
99	Discharge Valve Stop	—	—
100	Valve Plate Gasket	—	—
101	Discharge Valve Stop Cap Screw	—	—
102	Discharge Valve Stop Lockwasher	—	—
103	Valve Plate Dowel	—	—
104	Oil Drain Plug (New Design SAE Fitting and O-Ring)	—	—

2.9 — Exploded View - 6-Cylinder 06E Compressor

Complete parts breakdown shown for reference only. Some parts may be pictured prior to design changes and not all parts are available as replacements.

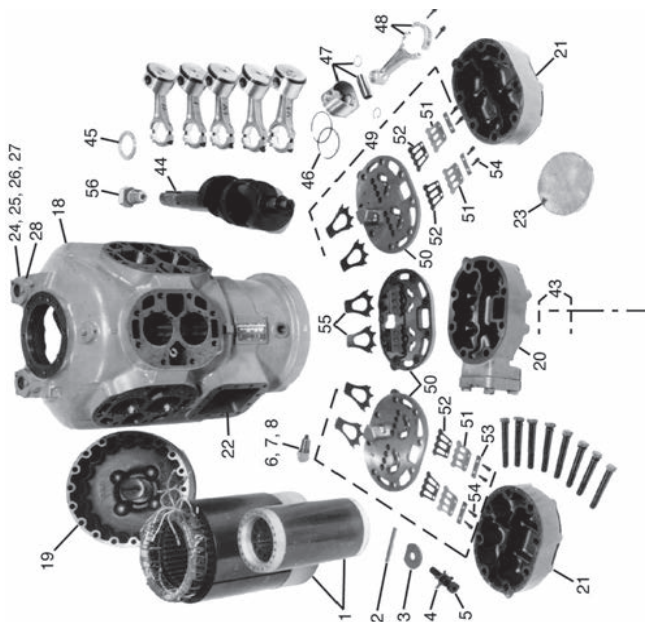

LEGEND

- 1 — Compressor Motor - Stator and Rotor
- 2 — Motor Key
- 3 — Rotor Plate Washer
- 4 — Rotor Lock Washer
- 5 — Rotor Lock Bolt
- 6 — Motor Lock Bushing
- 7 — Roll Pin
- 8 — Acorn Nut and Gasket

- 10 Terminal Box Assembly
- 12 Terminal Plate Assembly
- 14 Terminal Bolt Assembly
- 18 Compressor Crankcase
- 19 Motor End Cover
- 20 Cylinder Head - Center Bank
- 21 Cylinder Head - Side Bank (Unloader Head Not Shown)
- 22 Internal Relief Valve
- 23 Crankcase Oil Filter Screen
- 24 Oil Sight Glass Assembly
- 25 Oil Sight Glass "O" Ring Gasket
- 26 Oil Sight Glass Screw
- 27 Oil Sight Glass Lock Washer
- 28 Pipe Plug Gasket (Hex Head)
- 29 Bottom Cover Plate
- 30 Pump End Bearing Head Assembly
- 31 Pump Rotor
- 32 Pump Vane
- 33 Pump Vane Spring
- 34 Pump Vane Spring Guide
- 35 Retaining Spring Guide
- 36 Oil Feed Guide Vane
- 37 Oil Feed Guide Vane Spring
- 38 Oil Pump Drive Segment
- 39 Screw, Soc Head 1/4 - 28 x 5/8 in.
- 40 Screw, Soc Head #10 - 32 x 1/2 in.
- 41 Cover Plate
- 42 Cover Plate Cap Screw
- 43 Oil Relief Piston
- 44 Crankshaft
- 45 Bearing Washer
- 46 Piston Rings (Oil and Compression)
- 47 Piston, Piston Pin and Retaining Ring Assembly

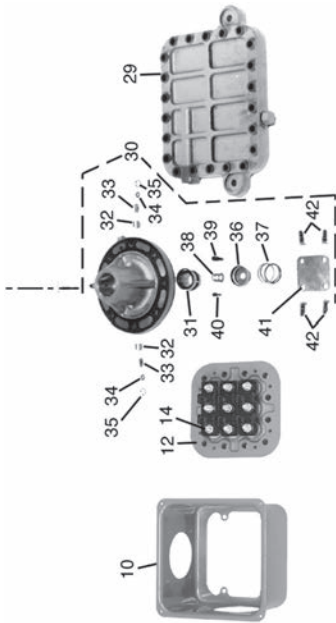

- 48 Connecting Rod and Cap Assembly
- 49 Valve Plate Assembly
- 50 Valve Plate
- 51 Discharge Valve Stop
- 52 Discharge Valve
- 53 Valve Stop Support
- 54 Cap Screw, Valve Stop
- 55 Suction Valve (Backers for A/C Models Not Shown see Fig. 6, page 36)
- 56 Check Valve (Use Only with Parallel Compressor Installations)

2.10 — Torque Guide - 06D and 06CC (16 to 37 Cfm) Compressors

SIZE DIAMETER (in.)	THREADS PER INCH	TORQUE RANGE (FT-LB)	TORQUE RANGE (NM)	USAGE
1/16	Pipe	8-12	11-16	Pipe plug crankshaft
1/8	Pipe	6-10	8-14	Oil return check valve
No. 10	32	4-6	5-8	Oil pump drive segment
1/4	Pipe	20-25	27-34	Pipe plug
1/4	20	10-12	14-16	Con-rod cap screw
1/4	28	12-15	16-20	Baffle plate crankshaft Side shield Oil pump drive segment Unloader
5/16	18	16-20 16-20 16-20 16-20 16-20 20-25 20-33	22-27 22-27 22-27 22-27 22-27 27-34 27-44	Cover plate bearing head Terminal plate cap screw Interstage outlet (CC) Interstage manifold (CC) Liquid injection (CC) Suction manifold (CC) Suction service valve Discharge service valve
3/8	16	30-35	40-48	P.E. bearing head, crankcase Bottom plate, crankcase Compressor foot Cylinder head Motor end cover, crankcase
3/8	24- SAE	6-12	8-16	P.E. bearing head at 10-o'clock position NOTE: Not a field usable fitting
7/16	14	55-60	75-81	Motor end cover, crankcase
7/16	20- SAE	6-12	8-16	Oil drain, on bottom cover plate 4-cyl (18-20 Cfm) and 6-cyl 06D
1/2	20	10-12	14-16	Oil pressure regulator
1/2	13	80-90	109-122	Suction service valve
5/8	11	25-30	34-40	Equalization spinner tube assembly
1-1/2	18	35-45	48-61	Oil level sight glass

LEGEND

(CC) - Compound Cooling compressors only

NM - Newton meter (metric torque rating)

SAE - Society of Automotive Engineers

*See Fig. 31, detail view, for jam locations.

Torque for jam nut #3 for compressors manufactured after 0203J--. For compressors built before this, jumper bar must be under jam nut

#3 or Loctite #089 applied to jam nut #2, or use 12 ft.-lb.

NOTE: Bolt sizes and thread pitch: Compressors are built using English unit bolts. The bolts have no exact metric equivalents. Therefore, to prevent possible cross-threading, loose bolts, or damage to threaded portions of the casing, comparable metric measurements are not included.

2.11 — Torque Guide - 06E and 06CC (50 to 99 Cfm) Compressors

SIZE DIAMETER (in.)	THREADS PER INCH	TORQUE RANGE (FT-LB)	TORQUE RANGE (NM)	USAGE
1/16	Pipe	8-12	11-16	Pipe plug crankshaft
1/8	Pipe	10-12	14-16	Orifice crankcase
No. 10	32	4-6	5-8	Oil pump drive segment
1/4	20	10-12 1.5-2.5	14-16 2-3	Con-rod cap screw Motor lead set screw terminal plate
1/4	28	3-5 4-6 12-15 12-15 12-15	4-7 5-8 16-20 16-20 16-20	Sight glass Cylinder head gasket tab screw Terminal box Unloader valve Discharge valve stop Oil pump drive segment
5/16	18	16-20 20-25	22-27 27-34	Cover plate bearing head Discharge service valve (4-cyl)
3/8	16	18 18 18 10-20 30-35 30-35 30-35	24 24 24 14-17 40-48 40-48 40-48	Terminal post jam nut #1* Terminal post jam nut #2* Terminal post jam nut #3* Oil plug bearing head Bottom plate, crankcase Compressor foot Terminal block
3/8	24- SAE	8-12	11-16	P.E. Bearing head at 10 o'clock position NOTE: Not a field usable fitting
5/8	18- SAE	25-40	27-54	Access port under motor barrel
7/16	14	55-60 55-60	75-81 75-81	Motor end cover, crankcase Bearing head, crankcase
7/16	20- SAE	8-12	11-16	Oil drain on bottom plate
1/2	13	80-90 80-90 80-90 85-100 85-100 85-100	109-122 109-122 109-122 115-136 115-136 115-136	Discharge service valve (6-cyl) Interstage outlet (CC) Suction service valve (1-5/8) Interstage manifold (CC) Suction manifold (CC) Cylinder head
1/2	Pipe	30-40	40-54	Cylinder head sensor
5/8	11	25-30 90-100	34-40 122-136	Rotor lock crankshaft Suction service valve (2-1/8)
3/4	16	50-60	68-81	Stator lock acorn nut
1-1/8	18	30-40	40-54	Pressure relief valve

See Table 2.10 for Notes and Legend (page 60).

3.0 — COMPRESSOR AND PARTS DATA

3.1 — 06D Series Compressors - Physical Data (Page 1 of 2)

CARRIER/ CARLYLE MODEL NUMBER	STANDARD SERVICE REPLACEMENT MODEL	SUCTION TEMPERATURE RANGE ... (a)									
		R-404A/507, R-448A and R-449A				R-134a				R-407A, R-407C and R-407F	
		Deg. F	Deg. C	Deg. F	Deg. C	Deg. F	Deg. C	Deg. F	Deg. C	Deg. F	Deg. C
06DM8080...	06DM8086...	0 to 50	-18 to 10	—	—	—	—	—	—	0 to 55	-18 to 13
06DR1090...	06DR1096...(b)	-40 to 0	-40 to -18	-10 to 55	-23 to 13	-10 to 55	-23 to 13	-35 to 0	-37 to -18	-35 to 0	-37 to -18
06DR0130...	06DR0136...(c)	-40 to 0	-40 to -18	-10 to 55	-23 to 13	-10 to 55	-23 to 13	-35 to 0	-37 to -18	-35 to 0	-37 to -18
06DM3130...	06DM3136...(c)	0 to 50	-18 to 0	—	—	—	—	0 to 55	-18 to 7	0 to 55	-18 to 7
06DR3160...	06DR3166...(c)	-40 to 25	-40 to -4	-10 to 55	-23 to 13	-10 to 55	-23 to 13	-35 to 25	-37 to -4	-35 to 25	-37 to -4
06DM3160...	06DM3166...(c)	0 to 25	-18 to -4	-10 to 55	-23 to 13	-10 to 55	-23 to 13	0 to 55	-18 to 7	0 to 55	-18 to 7
06DR7180...	06DR7186...	-40 to 0	-40 to -18	-10 to 55	-23 to 13	-10 to 55	-23 to 13	-35 to 0	-37 to -18	-35 to 0	-37 to -18
06DA8182...	06DA8186...	0 to 50	-18 to 10	—	—	—	—	0 to 55	-18 to 13	0 to 55	-18 to 13
06DR8200...	06DR8206...	-40 to 40	-40 to 4	-10 to 55	-23 to 13	-10 to 55	-23 to 13	-40 to 25	-40 to -4	-40 to 25	-40 to -4
06DR7240...	06DR7246...	-40 to 25	-40 to 4	-10 to 55	-23 to 13	-10 to 55	-23 to 13	-40 to 25	-40 to -4	-40 to 25	-40 to -4
06DA8242...	06DA8246...	0 to 50	-18 to 10	—	—	—	—	0 to 55	-18 to 13	0 to 55	-18 to 13
06DR7250...	06DR7256...	-40 to 25	-40 to 4	-10 to 55	-23 to 13	-10 to 55	-23 to 13	-40 to 25	-40 to -4	-40 to 25	-40 to -4
06DA8252...	06DA8256...	0 to 50	-18 to 10	—	—	—	—	0 to 55	-18 to 13	0 to 55	-18 to 13
06DR2280...	06DR2286...	-40 to 25	-40 to 4	-10 to 55	-23 to 13	-10 to 55	-23 to 13	-40 to 25	-40 to -4	-40 to 25	-40 to -4
06DA3282...	06DA3286...	0 to 50	-18 to 10	—	—	—	—	0 to 55	-18 to 13	0 to 55	-18 to 13
06DR3370...	06DR3376...	-40 to 25	-40 to 4	-10 to 55	-23 to 13	-10 to 55	-23 to 13	-30 to 25	-40 to -4	-30 to 25	-40 to -4
06DM3370...	06DM3376...	0 to 25	-18 to 10	-10 to 55	-23 to 13	-10 to 55	-23 to 13	0 to 45	-18 to 7	0 to 45	-18 to 7
06DA5342...	06DA5376...	0 to 50	-18 to 10	—	—	—	—	0 to 55	-18 to 13	0 to 55	-18 to 13
06DR5410...	06DR5416...	-40 to 25	-40 to 4	—	—	—	—	-40 to 25	-40 to -4	-40 to 25	-40 to -4

(a) Approximate condensing temperature ranges. CHECK ACTUAL PERFORMANCE DATA FOR ANY NEW APPLICATION ESPECIALLY AT OR NEAR UPPER OR LOWER LIMIT: Low Temperature=70 to 120°F (21 to 49°C), Medium Temperature=80 to 130°F (27 To 54°C) and High Temperature (R-407A, C, F only) = 80 to 150°F (27 to 66°C).

(b) The 06DR 109 single phase compressor has a 3 HP (2.2 kW) motor.

(c) Service compressors have dual suction service valve locations, one on motor end and one near the oil pump.

3.1 — 06D Series Compressors - Physical Data (Page 2 of 2)

CARRIER/ CARLYLE MODEL NUMBER	MOTOR SIZE		DISPLACEMENT AT 1750 RPM				NO. OF CYL	BORE		STROKE		OIL CHARGE		NET WEIGHT	
	HP	kW	CFM	L/M	CFH	L/H (1,000)		in.	mm	in.	mm	Pints	Liters	Lb	Kg
06DM8080...	3	2.2	8.0	227	480	13.59	2	50.8	1 1/4	31.8	3	1.4	160	73	
06DR1090...	2 (b)	1.5	8.7	246	522	14.78	2	50.8	1 3/8	34.9	3	1.4	190	73	
06DR0130...	3	2.2	13.0	368	786	22.26	4	50.8	1	25.4	4 1/2	2.1	230	104	
06DM3130...	5	3.7	13.0	368	786	22.26	4	50.8	1	25.4	4 1/2	2.1	235	107	
06DR3160...	5	3.7	15.9	450	954	27.01	4	50.8	1 1/4	31.8	4 1/2	2.1	235	107	
06DM3160...	5	3.7	15.9	450	954	27.01	4	50.8	1 1/4	31.8	4 1/2	2.1	235	107	
06DR7180...	5	3.7	18.3	518	1100	31.09	4	50.8	1 7/16	36.5	5 1/2	2.6	250	113	
06DA8182...	6 1/2	4.9	18.3	518	1100	31.09	4	50.8	1 7/16	36.5	5 1/2	2.6	250	113	
06DR8200...	6 1/2	4.9	20.0	566	1200	33.00	4	50.8	1 9/16	39.7	5 1/2	2.6	260	118	
06DR7240...	6 1/2	4.9	23.9	677	1435	40.60	6	50.8	1 1/4	31.8	8	3.8	310	141	
06DA8242...	7 1/2	5.6	23.9	677	1435	40.60	6	50.8	1 1/4	31.8	8	3.8	310	141	
06DR7250...	6 1/2	4.9	23.9	677	1435	40.60	6	50.8	1 1/4	31.8	8	3.8	310	141	
06DA8252...	7 1/2	5.6	23.9	677	1435	40.60	6	58.8	1 1/4	31.8	8	3.8	315	143	
06DR2280...	7 1/2	5.6	28.0	793	1680	47.57	6	50.8	1 15/32	37.3	8	3.8	315	143	
06DA3282...	10	7.5	28.0	793	1680	47.57	6	50.8	1 15/32	37.3	8	3.8	315	143	
06DR3370...	10	7.5	37.1	1050	2225	63.03	6	50.8	1 15/16	49.2	8	3.8	325	147	
06DM3370...	10	7.5	37.1	1050	2225	63.03	6	50.8	1 15/16	49.2	8	3.8	325	147	
06DA5372...	15	11.2	37.1	1050	2225	63.03	6	50.8	1 15/16	49.2	8	3.8	325	147	
06DR5410...	15	11.2	41.0	1161	2460	69.66	6	50.8	2 5/32	54.6	8	3.8	325	147	

LEGEND

CFH - Cubic ft per hour

L/H - Liters per hour

L/M - Liters per minute

3.2 — 06E Series Compressors - Physical Data (Page 1 of 2)

CARRIER/ CARLYLE MODEL NUMBER (d)	STANDARD SERVICE REPLACEMENT MODEL	SUCTION TEMPERATURE RANGE ... (a)					
		R-404A/507, R-448A and R-449A		R-134a		R-407A, R-407C and R-407F	
		Deg. F	Deg. C	Deg. F	Deg. C	Deg. F	Deg. C
06ER450...	06EY450...	-40 to 0	-40 to -18	-10 to 55	-23 to 13	-35 to 0	-37 to -18
06EM450...	06EZ450...	0 to 25	-18 to -4	-10 to 55	-23 to 13	0 to 45	-18 to 7
06EA550...	06ET250...	0 to 50	-18 to 10	—	—	0 to 55	-18 to 13
06ER166... (e)	06EY466...	-40 to 0	-40 to 18	-10 to 55	-23 to 13	-35 to 0	-37 to -18
06EM266... (e)	06EZ266...	0 to 45	-18 to 7	-10 to 55	-23 to 13	0 to 50	-18 to 10
06ER465...	06EY465...	-40 to 0	-40 to -18	-10 to 55	-23 to 13	-35 to 0	-37 to -18
06EA565...	06ET265...	0 to 50	-18 to 10	-10 to 55	-23 to 13	0 to 50	-18 to 13
06ER475...	06EY475...	-40 to 0	-40 to -18	-10 to 55	-23 to 13	-35 to 0	-37 to -18
06EM475...	06EZ475...	0 to 40	-18 to 4	-10 to 55	-23 to 13	0 to 45	-18 to 7
06EA575...	06ET275...	0 to 50	-18 to 10	—	—	0 to 55	-18 to 13
06ER399...	06EY399...	-40 to 0	-40 to -18	-10 to 55	-23 to 13	-35 to 0	-37 to -18
06EM499...	06EZ499...	0 to 40	-18 to 4	-10 to 55	-23 to 13	0 to 45	-18 to 7
06EA599...	06ET299...	0 to 50	-18 to 10	—	—	0 to 55	-18 to 13

(a) Approximate condensing temperature ranges. CHECK ACTUAL PERFORMANCE DATA FOR ANY NEW APPLICATION ESPECIALLY AT OR NEAR UPPER OR LOWER LIMIT: Low Temperature=70 to 120°F (21 to 49°C), Medium Temperature=80 to 130°F (27 TO 54°C) and High Temperature (R-407A, C, F only) = 80 to 150°F (27 to 66°C).

(d) The models shown are new oil-less models. Models with oil had a 0, 1, or 2 in the 5th digit of the model number.

(e) The 06ER166 and 06EM266 models are no longer built new, but service replacements are built and available. For new applications, the 06ER166 and 06EM266 models have been replaced by the 06ER465 and 06EA565.

3.2 — 06E Series Compressors - Physical Data (Page 2 of 2)

CARRIER/ CARLYLE MODEL NUMBER (d)	MOTOR SIZE		DISPLACEMENT AT 1750 RPM				NO. OF CYL	BORE		STROKE		OIL CHARGE		NET WEIGHT	
	HP	kW	CFM	L/M	CFH	L/H (1,000)		in.	mm	in.	mm	Pints	Liters	Lb	Kg
06ER450...	15	11.2	50.3	1424	3016	85.45	4	2 11/16	68.3	2 3/16	55.6	14	6.6	430	195
06EM450...	15	11.2	50.3	1424	3016	85.45	4	2 11/16	68.3	2 3/16	55.6	14	6.6	430	195
06EA550...	20	14.9	50.3	1424	3016	85.45	4	2 11/16	68.3	2 3/16	55.6	14	6.6	430	195
06ER166... (e)	20	14.9	66.0	1869	3960	112.1	4	2 11/16	68.3	2 7/8	73.0	14	6.6	430	195
06EM266... (e)	25	18.6	66.0	1869	3960	112.1	4	2 11/16	68.3	2 7/8	73.0	14	6.6	430	195
06ER465...	20	14.9	68.3	1934	4096	116.0	6	2 11/16	68.3	1 63/64	50.4	19	9.0	480	218
06EA565...	25	18.6	68.3	1934	4096	116.0	6	2 11/16	68.3	1 63/64	50.4	19	9.0	485	220
06ER475...	20	14.9	75.4	2135	4524	128.1	6	2 11/16	68.3	2 3/16	55.6	19	9.0	490	222
06EM475...	25	18.6	75.4	2135	4524	128.1	6	2 11/16	68.3	2 3/16	55.6	19	9.0	490	222
06EA575...	30	22.4	75.4	2135	4524	128.1	6	2 11/16	68.3	2 3/16	55.6	19	9.0	490	222
06ER399...	30	22.4	99.0	2803	5940	168.2	6	2 11/16	68.3	2 7/8	73.0	19	9.0	500	227
06EM499...	35	26.1	99.0	2803	5940	168.2	6	2 11/16	68.3	2 7/8	73.0	19	9.0	505	229
06EA599...	40	29.8	99.0	2803	5940	168.2	6	2 11/16	68.3	2 7/8	73.0	19	9.0	520	236

LEGEND

CFH - Cubic ft per hour

L/H - Liters per hour

L/M - Liters per minute

3.3 — 06CC Series Compressors - Physical Data (Page 1 of 2)

CARRIER/ CARLYLE MODEL NUMBER	STANDARD SERVICE REPLACEMENT MODEL	SUCTION TEMPERATURE RANGE ...(f)					
		R-404A/507, R448-A and R-449A		R-134a		R-407A, R-407C and R-407F	
		Deg. F (h)	Deg. C (h)	Deg. F	Deg. C	Deg. F	Deg. C
06CC016...(g)	06CY016...	-40 to -10	-40 to -23	(i)	(i)	-40 to -10	-40 to -23
06CC017...	06CY017...	-40 to -10	-40 to -23	(i)	(i)	-40 to -10	-40 to -23
06CC018...(g)	06CY018...	-40 to -10	-40 to -23	(i)	(i)	-40 to -10	-40 to -23
06CC124...	06CY124...	-60 to -10	-51 to -23	(i)	(i)	-40 to -10	-40 to -23
06CC125...	06CY125...	-60 to -10	-51 to -23	(i)	(i)	-40 to -10	-40 to -23
06CC228...	06CY228...	-60 to -10	-51 to -23	(i)	(i)	-40 to -10	-40 to -23
06CC337...	06CY337...	-60 to -10	-51 to -23	(i)	(i)	-40 to -10	-40 to -23
06CC550...(g)	06CY550...	-40 to -10	-40 to -23	(i)	(i)	-40 to -10	-40 to -23
06CC665...	06CY665...	-60 to -10	-51 to -23	(i)	(i)	-40 to -10	-40 to -23
06CC675...	06CY675...	-60 to -10	-51 to -23	(i)	(i)	-40 to -10	-40 to -23
06CC899...	06CY899...	-60 to -10	-51 to -23	(i)	(i)	-40 to -10	-40 to -23

(f) Approximate condensing temperature ranges. CHECK ACTUAL PERFORMANCE DATA FOR ANY NEW APPLICATION, ESPECIALLY AT OR NEAR UPPER OR LOWER LIMIT: Low Temperature = 70 to 130°F (21 to 55°C).

(g) To provide a 6-cylinder body needed for Compound Cooling, the normal 4-cylinder model 16, 18 and 50 Cfm compressors are built using the 24, 18, and 65 Cfm 6-cylinder bodies respectively. The actual Cfm reduction is achieved by modifying the running gear.

(h) R404A/R-507 CANNOT be used in the small "D" body size Compound Cooling compressors (16 to 37 Cfm), manufactured prior to Serial No. 2099J.

(i) R-134a CANNOT be used in any Compound Cooling compressor.

3.3 — 06CC Series Compressors - Physical Data (Page 2 of 2)

CARRIER/ CARLYLE MODEL NUMBER	MOTOR SIZE			DISPLACEMENT AT 1750 RPM				NO. OF CYL	BORE		STROKE		OIL CHARGE		NET WEIGHT		BODY SIZE
	HP	kW	CFM	CFM	L/M	CFH	L/H (1,000)		in.	mm	in.	mm	Pints	Liters	Lb	Kg	
06CC016... (g)	5	3.7	15.9	450	450	954	27.01	6	2	50.8	1 1/4	31.8	9.5	4.5	330	150	D
06CC017...	5	3.7	15.9	450	450	954	27.01	6	2	50.8	1 1/4	31.7	9.5	4.5	330	150	D
06CC018... (g)	5	3.7	18.3	518	1100	31.09	6	2	50.8	1 15/32	37.3	9.5	4.5	325	147	D	
06CC124...	6 1/2	4.9	23.9	677	1435	40.60	6	2	50.8	1 1/4	31.8	9.5	4.5	335	152	D	
06CC125...	6 1/2	4.9	23.9	677	1435	40.60	6	2	50.8	1 1/4	31.8	9.5	4.5	330	150	D	
06CC228...	7 1/2	5.6	28.0	793	1680	47.57	6	2	50.8	1 15/32	37.3	9.5	4.5	340	154	D	
06CC337...	10	7.5	37.1	1050	2225	63.03	6	2	50.8	1 15/16	49.2	9.5	4.5	345	156	D	
06CC550... (g)	15	11.2	50.3	1424	3016	85.45	6	2 11/16	68.3	1 63/64	50.4	19	9.0	545	247	E	
06CC665...	20	14.9	68.3	1934	4096	116.0	6	2 11/16	68.3	1 63/64	50.4	19	9.0	555	252	E	
06CC675...	20	14.9	75.4	2135	4524	128.1	6	2 11/16	68.3	2 3/16	55.6	19	9.0	555	252	E	
06CC899...	30	22.4	99.0	2803	5940	168.2	6	2 11/16	68.3	2 7/8	73.0	19	9.0	580	263	E	

LEGEND

CFH - Cubic ft per hour

L/H - Liters per hour

L/M - Liters per minute

3.4 — 06D, E High Efficiency (H.E.) Compressors

High efficiency compressors were phased in between 1985 and 1987. A high efficiency compressor can be identified as follows:

All 06D H.E. compressors (new or service replacement) have the number “3” in the 11th digit of the model number. See page 3 for examples.

The 06E compressor model numbers did not change. To determine if a 06E compressor is high efficiency, check the serial number. The following serial numbers indicate high efficiency:

06EA models start with S/N 4585J...

06EM models start with S/N 0786J...

06ER models start with S/N 2287J...

All 06CC compressors are H.E. design.

All service compressors are high efficiency, except for some “D” body units without a “3” in the 11th digit of the model numbers.

NOTE: The 06E H.E. valve plates are identified by an elongated ear protruding from the side of the valve plate, in contrast to the standard efficiency valve plates which have one (A/C - EM, EZ, etc.) or two (refrigeration - ER, EY) rounded ears.

3.5 — Compressor Bodies Without Oil

In 1995 Carlyle began supplying new and service compressors with no oil in the crankcase due to the introduction of HFC/POE systems. This eliminates the need to drain mineral oil from the crankcase when alkylbenzene or POE oil is to be used. POE oil is very hygroscopic (will readily pick up and retain moisture from the air). See Section 2.2, page 11 for Carlyle approved system start-up instructions and Section 3.6 below for the proper refrigerant oils.

3.6 — Refrigerants and Oils for 06D, E, CC Compressors

The following sections list approved refrigerants and oils for the Carlyle 06D, E, CC compressors:

Refer to the following chart for Totaline® Part Numbers for available oils:

OIL	PART NO.
Z150	ALKYLBENZENE (AB) OIL P903-2001 (1 Gal) P903-2005 (5 Gal) P903-2025 (1 Quart)
Mineral Refr Oil 150	MINERAL OIL P903-0101 (1 Gal) P903-0105 (5 Gal) P903-0155 (55 Gal)
POE68*	POLYOL-ESTER (POE) OIL P903-1001 (1 Gal) P903-1025 (1 Quart) P903-1005 (5 Gal)
POE68e	POLYOL-ESTER (POE) OIL P903-1725 (1 Quart) P903-1701 (1 Gal) P903-1705 (5 Gal)

* Do not use in low temperature applications.

FOR HFCs:

Carlyle has approved the following UL listed refrigerants **R-404A, R-407A, R-407C, R-407F, R-448A, R-449A, R-450A, R-452A, and R-507** for use in 06D, E, and CC compressors. UL listed **R-134a and R-513A** are only approved for use in 06D and E compressors.

The following POLYOL-ESTER (POE) are approved oils for HFCs:

Totaline® (see Note 5).....	P903-1001, 1701
Castrol (see Note 5).....	E68
ICI Emkarate.....	RL68H
CPI.....	CP-2916S
CPI.....	Solest 68
BP Marine Enersyn.....	MP-S68

All POE oils are very hygroscopic (will readily pick up and retain moisture from the air) and should be used completely once the container is opened. It is extremely difficult to reseal the oil container effectively enough to prevent moisture absorption, which in turn forms damaging acids.

NOTES:

1. The use of any non-approved refrigerant may be dangerous and may void the warranty. Contact the Carlyle Compressor engineering department before using any refrigerant or oil not listed in this guide as approved for use in a Carlyle semi-hermetic compressor.
2. Using the wrong type or weight of oil for the refrigerant selected will void the warranty.
3. Follow the refrigerant and/or oil manufacturer instructions when installing or retrofitting.
4. Castrol SW68 (Totaline® P903-1001) is approved for use in Carrier chiller applications as well as Carrier and Carlyle semi-hermetic compressors for air conditioning and medium temperature applications. **Castrol SW68 (Totaline® P903-1001) cannot be used in any new low temperature refrigeration applications using Carlyle OEM semi-hermetic compressors. Castrol E68 is approved for use in Carlyle OEM compressors for low, medium, and high temperature ranges.**
5. All HFC/POE applications require a crankcase heater.
6. Moisture must be kept below 50 ppm for POE oils.
7. In retrofit applications, a high flow oil pump is required.

For HFCs not listed above, please contact Carlyle Engineering for oil recommendations.

FOR CFCs:

Carlyle has historically approved the following UL listed refrigerants **R-22, R-500, and R-502** for use in 06D, E, and CC compressors.

The following MINERAL/ALKYL BENZINE are approved oils for CFCs:

Totaline.....	P903-2001
Witco.....	Suniso 3GS
Shrieve Chemical.....	Zerol 150
Texaco Capella.....	WFI-32-150
IGI Petroleum Ind.....	CRYOL -150

NOTE: For CFCs not listed above, please contact Carlyle Engineering for oil recommendations.

 **WARNING**

A number of blends are not approved. Some may create a hazardous situation. Carlyle requires all refrigerants used in our compressors to be A1/A1 (low flammability/low toxicity). The rating is based on ASHRAE 34 safety standard. Not all A1/A1 refrigerants are approved for use in Carlyle compressors. Some of the refrigerants or blends available are either flammable (A1/A2 or A1/A3) and/or toxic (A1/B1 or A1/B3). Some A1/A1 refrigerants can change ratings if contaminated. Any replacement refrigerant must operate with the same pressure levels and temperature ranges as the refrigerant being replaced. **Do not use any refrigerant not specifically approved in this guide unless you have obtained approval from the Carlyle Compressor engineering department.**

3.7 — Oil Viscosity and Pour Points

The viscosity of oils used in Carlyle reciprocating compressors is ISO 68 (centistoke) for all POE oils and 150 Saybolt Seconds Universal (150 SSU or 150 SUS) or ISO 32 for mineral and alkylbenzene oils. Using oil with a different viscosity without approval from the Carlyle Engineering Department will void the warranty.

The oils listed in Sections 3.6 and 3.7 and the viscosity listed above can be used down to -40°F (-40°C). If your system runs

at a lower temperature, please contact Carlyle Engineering for an oil recommendation.

3.8 — Oil Additives

No oil additive is allowed without written approval from the Carlyle Engineering Department. The use of any unauthorized additive will void the warranty.

3.9 — Oil Pressure

All new 06D, E, CC compressors are supplied with oil safety switch connections. Carlyle has introduced a new high flow oil pump and changed oil pressure specifications due to changes in lubricants and refrigerants. The following data notes the proper oil pressure range based on the compressor's date of manufacture:

STARTING MARCH 1994 WITH S/N 1094J AND LATER:

- For new OEM 06D and 06CC (16 to 37 Cfm) compressors, the pressure is 18 to 26 psi (1.2 to 1.8 Bars)
- For new OEM 06E and 06CC (50 to 99 Cfm) compressors, the pressure is 18 to 34 psi (1.2 to 2.3 Bars)
- Note that service compressors did not receive the new pump until serial number starting with S/N 2994M and later.

BETWEEN MAY 1984 AND MARCH 1994 OR BETWEEN S/N 2084J AND 1094J:

- For all 06D, E, CC compressors, the oil pressure is 16 to 22 psi (1.1 to 1.5 Bars)

BEFORE MAY 1984 OR BEFORE S/N 2084J:

- For all 06D,E compressors, the oil pressure is 12 to 18 psi (0.8 to 1.2 Bars)
- For more information about the high flow oil pump, see Section 3.10.

3.10 — High Flow Oil Pump (Bearing Head)

Carlyle introduced a new high flow oil pump to provide improved lubrication with the new HFC refrigerants and POE lubricants. The pump is a durable, automatically reversible, high flow design. The high flow design improves lubrication, especially with the new HFC/POE combination, and provides improved lubrication in the case of a flooded start. This oil pump is standard on all new and service compressors. See Section 3.9 above for details on oil pressure. For service replacement, authorized service locations will have the new high flow oil pump only. See Section 3.11 below.

3.11 — Replacement Oil Pump/Pump End Bearing Package

The oil pump and pump end bearing are an integral part called the pump end bearing head. If either the oil pump or the bearing requires replacement, order part as noted below:

PUMP END BEARING HEAD PACKAGE	USAGE
06DA660126	All 06D, 06CC (16 to 37 Cfm) compressors
06EA660157	All 06E, 06CC (50 to 99 Cfm) compressors

NOTE: The above pump end bearing head packages include a bearing head with the high side oil safety switch connection. This pump is recommended for all CFC, HCFC, and HFC refrigeration applications.

3.12 — Oil Pressure Safety Switch

Carlyle uses as standard the 120-second time delay oil safety switch, as this time period is preferred for HFC/POE systems. This is a change from the 45 to 60-second time delay used previously with CFC and HCFC systems. It is not necessary to change out the older, shorter time delay switch unless the unit is converted to an HFC/POE system.

The oil safety switch protects the compressor when lubrication is lost for more than 120 seconds. The switch closes the control circuit at start-up allowing the compressor to run for 120 seconds. Operating oil pressure must reach the minimum required start pressure above suction pressure within 120 seconds for the switch to remain closed, which allows the compressor to run. If the operating oil pressure falls to below the minimum stop pressure above suction for longer than 120 seconds, the switch will open the control circuit, shutting down the compressor.

Carlyle has approved the following oil safety switches for all applications with 06D, E, CC compressors:

CARLYLE PART NO.	TIME DELAY (SEC)	CONN.	PRESSURE DIFF. (PSI)		VOLTS	RESET	REMOTE ALARM CIRCUIT
			START	STOP			
060B210966	120	1/4-in. Male Flares	8-11	4-8	115/230	Manual	Yes
060B2164	120	36-in. Long Capacity Tube 1/4-in. SAE Nuts	8-11	4-8	115/230	Manual	Yes
06DA509570	120	N/A	12-14	8-10	115/230	Manual	Yes

Use of an oil safety switch is recommended/required by Carlyle as noted in the chart below:

TYPE OF SYSTEM	USING 06D COMPRESSORS	USING 06E COMPRESSORS	USING 06CC COMPRESSORS
Single Compressor without Unloading	Recommended	Required	Required
Single Compressor with Unloading	Recommended	Required	N/A
Multiple Compressors without Unloading	Required	Required	Required
Multiple Compressors with Unloading	Required	Required	N/A

Electronic Oil Pressure Safety Switch

See Bulletin 11T-2 at www.carlylecompressor.com

Description:

The new Carlyle Oil Pressure Safety Switch (OPSS) is an enhanced means for protecting the compressor from loss of lubrication. The new Carlyle OPSS is an upgrade to the Danfoss MP54 and Penn P545 and will protect the compressor from damage due to low oil differential pressure in recip compressors with oil pump lubrication. The lack/loss of lubrication will result in serious damage of compressor bearings and sliding surfaces.

Replacement Parts:

- P/N: 06DA660170 (Includes 06DA509570, 06DA509571, and 06DA660169)
- P/N: 06DA509570, OPSS Electronic Unit
- P/N: 06DA509571, OPSS Screw-in Sensor
- P/N: 06DA660169, Sensor Block Kit

OPSS Function:

- The OPSS differential oil pressure switch consists of two parts: a sensor unit and an electronic unit. The electronic unit can easily be disconnected from the sensor without opening the oil/refrigeration circuit.
- The OPSS serves to monitor the oil differential pressure of the oil pumps in refrigeration compressors. For this, a screw-in sensor is mounted directly to the pump housing and measures both the compressor's suction and oil pump pressure simultaneously. The screw-in sensor is thereby connected, by the sensor block, to the suction and high pressure side of the oil pump. Thus supplementary pipe connections are not needed.
- The OPSS electrical unit is fastened by a coupling ring to the screw-in sensor and can be removed without opening the oil/refrigeration circuit (not in direct contact with the oil circuit).

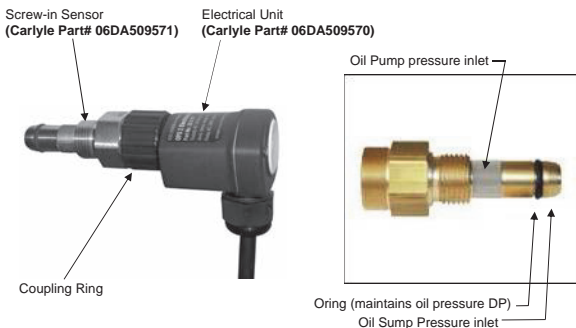

Fig. 19 — Oil Pressure Safety Switch

1.) OPSS Operation:

- The OPSS is a dual power low oil DP switch 120/240Vac (Blue/Brown wires).

- Compressor Start: Oil pressure monitoring is activated once the supply voltage is applied to the operating recognition signal, which is applied to D1 (violet wire) via an auxiliary contactor or motor contactor (see wiring diagram). Following a compressor start, the OPSS allows for a 120 second oil pressure transition delay to allow the compressor to reach steady oil pressures. The differential pressure monitoring is activated after the expiration of the 120 second compressor starting transition time.
- A low differential oil pressure (9 psig) for a continuous 120 seconds will lead to a locked switch and trip the compressor off.
- Also, a time integrated low differential oil pressure (9 psig) that is fluctuating 60% of the time \leq to 9 psig over a 5 minute rolling window will lead to a locked switch and trip the compressor off.
- A manual reset of the relay can be carried out by the built-in push button, or by activating the operating recognition (D1) or by a 5 second power reset.
- The monitoring of internal errors is always active. Any faults that occur in any operational phase will lead to a locked switch off of the relay after 5 seconds and trip the compressor. The potential-free relay contact can be looped into a safety circuit without an auxiliary relay. An installation check monitors for the proper assembly. An LED status will indicate if the OPSS is faulty or not correctly installed (See LED Status Table).
- The built-in LED indicates the actual operating state of the compressor's oil pump pressure. Once the oil DP preset value has been reached (13 psig), the LED light will be off and the OPSS output contacts remain in the closed position (Gray and Orange wires). If the differential oil pressure falls below the cut-out preset value (9 psig) for

a continuous 120 seconds or a time integrated low delta P for 120 seconds, the OPSS output contacts will open and shut down the compressor and indicate the status per the LED indicator. (See LED Status Table.)

2.) Oil Sensor Block Installation (06D/E/CC)

NOTE: 2-Cylinder 06D compressors (06DM808 and 06DR109) cannot support the Oil Sensor Block installation due to interference with the Service Valve position installed on the crankcase. Please contact Carlyle Engineering for options if you would like to apply the electronic OPSS to a 2-cylinder 06D compressor.

1. Remove cover plate bolts, cover plate and gasket from bearing head. (During reassembly be sure that spring and recess cup are in place and do not re-use factory installed gasket.)
2. Install the 1/4-in. NPT O-ring seal fitting into the high side oil pump pressure port on the compressor as shown (Torque to 20-25 ft/lbs):



Install 1/4" NPT
O-ring fitting.
(P/N 06EA407204)

Fig. 20 — Cover Plate Removed

3. The sensor block gasket (P/N 06DA504473) is installed between the bearing head and sensor block with the bead

side facing you. Lightly oil the gasket. Make sure the bearing head surface is clean and free from any debris.



Fig. 21 — OPSS Sensor Block Gasket

4. Next, install the sensor block (P/N 06EA507202) over the gasket and the 1/4" NPT O-ring seal fitting as shown. Mount the sensor block to the bearing head using the four 5/16"-18 x 1-1/4" Allen head bolts provided in the kit (Torque to 15-20 ft/lbs). (Be sure spring and recess cup are in place).

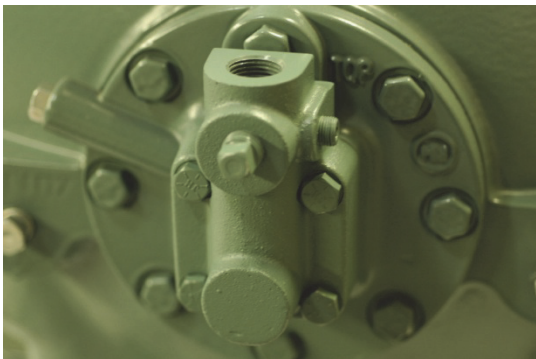

Fig. 22 — OPSS Sensor Block Installed

5. Install the OPSS sensor into the Sensor Block. Be sure the copper washer is in-place. Tighten the sensor's 1" hex nut securely to the sensor block (torque 45-55 ft/lbs).



Fig. 23 — OPSS Sensor Installed

6. Installation and Wiring for OPSS (06D/E/CC/M)
 - Install the coupling ring end of the OPSS electrical unit to the sensor by hand and secure tightly.

- The electrical connections for the OPSS electrical unit need to be carried out according to the proposal in the wiring diagram.

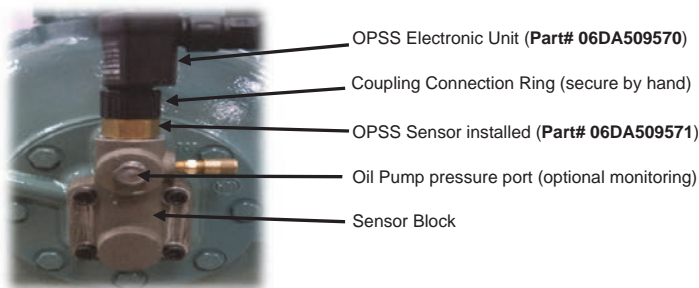
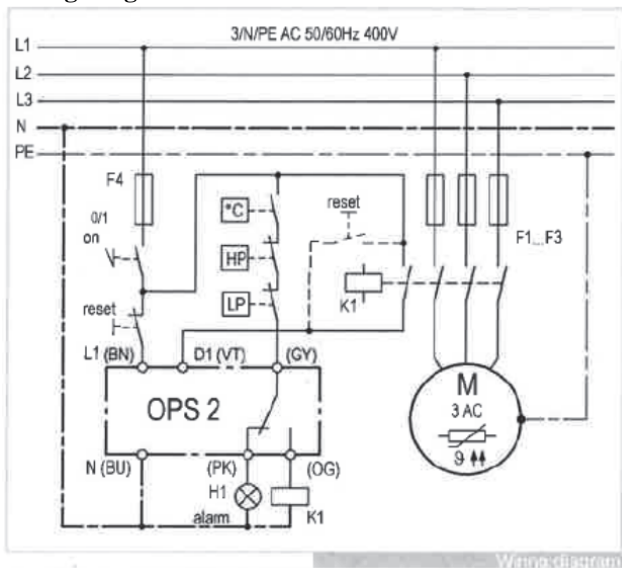

Fig. 24 — OPSS Complete Assembly

Technical specifications

Permitted Temperature	-22°F to +194°F
Differential Pressure	Cut-out 9 psig ±1 psig Reset 13 psig ±1 psig
Operating Pressure	435 psig
Electronic Unit (BN/BU) Dual Voltage Connection	AC 50/60 Hz 115-230V -15/+10%
Operating Recognition Connection (D1) Dual Voltage	AC 50/60 Hz 115-230V -15/+10%
Ambient Temperature Range	-22°F to 158°F
Delays:	
• Relay on after applying the supply voltage	3s ±1s
• Relay on after previous locking	120s ±5s
• Starting transition time D1 active	5s ±2s
• Relay off (error)	5s ±2s
• Relay off (diff. pressure missing)	120s ±5s (time integration)
• Reset by interrupting the supply voltage	About 5s
• Reset by button	About 1s
• Reset by operating recognition (D1)	About 1s
Output Relay	AC 240V 2.5A C300
Protection Class Acc. to EN60529	IP54 in built-in status

Wiring Diagram



The OPSS can be reset in three different ways:

- Disconnect the module from the power supply for 5 seconds.
- Push the reset button.
- Reset by operating recognition signal (D1), violet wire for 5 seconds.

Once the module is reset, the compressor is allowed to re-start again after a 120 second time delay.

LED Flash Codes:

Flashing 10 times per second:

- Internal Error.
- Voltage Supply too low.
- Electrical unit not completely attached to sensor.
- Operating recognition on but relay still off.

Flashing 1 time per second:

- Reset Delay















Continuous Light:

- Oil Differential Pressure low.

OFF:

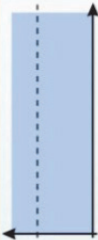
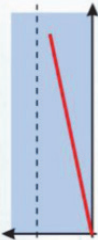
- Differential pressure OK, no error.

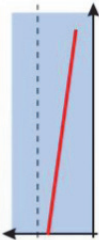
LED Status Table

				
				
1 Sec Flashing: Reset Delay	Continuous Flashing: Oil Differential Low, Compressor Trip.	No Light: Differential Pressure Good. Compressor running	Continuous Flashing: Time Integrated Oil Differential Low. Compressor off	10 Sec Flashing: OPSS Unit Fault
				

3.13 — 06CC, E Discharge Gas Cylinder Head Temperature Sensor and 06E Pressure Relief Valve

All OEM Carlyle 06EA, EM, ER compressors since 1982 are equipped with a discharge gas temperature sensor. The sensor is installed in the discharge or center head on all six-cylinder (three-head) models. The four-cylinder 06E compressors (two heads) have the sensor in the left side head as viewed from the oil pump end. All 06CC compressors have the sensor located in the discharge (high stage) head.

Pressure Relief Valve

All 06E compressors and all 06CC 50-99 cfm compressors are equipped with a pressure relief valve that relieves from discharge pressure to crankcase pressure. It is located under the center cylinder head on all 6-cylinder 06E and 06CC compressors, and under the discharge service valve on all 4-cylinder 06E compressors. The relief valve is sealed with a metal gasket:

Part Number Description

EB51FN272 - 400 psi Relief Valve (differential pressure)

6G65-1251 - Relief Valve, Gasket

An 11/16 in. drag link socket can be useful for removing or installing the relief valve.

When the discharge gas temperature in the cylinder head exceeds the sensor trip setting (see below), the sensor will open the control circuit and shut off the compressor. The head sensor must be wired into the control circuit by the OEM and is pilot duty only at 240V = 0.52A, at 115V = 1.04A. The sensors are threaded into the head without a well. Therefore, when changing a sensor, the compressor must first be isolated and evacuated.

CYLINDER HEAD TEMPERATURE SPECIFICATIONS

	Refrigeration from 1982 to mid-1998 for 06ER, EM, EY and EZ	All 06E and 06CC Compressors
Part Number	HN68GA295	HN68GA242
Opens	325° ± 8° F (163° ± 4°C)	295° ± 5° F (146° ± 3°C)
Closes	250° ± 12° F (121° ± 7°C)	235° F minimum (113°C)
Wire Color	Silver Grey	Black
Thread	1/2-in. NPT	1/2-in. NPT

NOTE: 325 F sensor is no longer available, for service replacement use HN68GA242.

NOTES:

1. Since 1993 all Carrier 06 series air conditioning compressors have been made without a sensor. All Carlyle OEM 06 series compressors are equipped with a sensor.
2. Starting in mid-1998 all Carlyle OEM compressors, including 06EA, EM, ER and all 06CC models, are built using the HN68GA242 sensor. The change to a single sensor model is due to the increased use of HFC refrigerants, which operate at lower temperatures.

3.14 — 06D, E Cylinder Head Cooling Fans

Cylinder head cooling fans are recommended on all applications where the saturated suction temperature (SST) is below 0°F (-18°C). A cylinder head cooling fan must be used for all R-22 single stage applications below 0°F (-18°C) and all R404A/507 single stage applications below -25°F (-32°C). A cylinder head cooling fan is recommended (but not required) for any two-stage (Compound Cooling) applications.

CYLINDER HEAD COOLING FAN REPLACEMENT PARTS

DESCRIPTION	06D, 06CC (16 to 37 Cfm)	06E, 06CC (50 to 99 Cfm)
Head cooling fan assembly - 208/230V	06DA680070	06DA680072
Head cooling fan assembly - 460V	06DA680071	06DA680073
Head cooling fan assembly, less mounting - 208/230V	06DA680074	06DA680074
Head cooling fan assembly, less mounting - 460V	06DA680075	06DA680075
Mounting kit	06DA680076	06DA680077
Replacement motor - 208/230V	06DA680079	06DA680079
Replacement motor - 460V	06DA680078	06DA680078
Replacement fan blade	06DA680080	06DA680080
Mounting stud nuts	3/8 - 16	1/2 - 13

3.15 — Capacity Control Accessory Packages (Suction Cut-Off Unloading Type)

The following suction cut-off capacity control packages are available to field convert those 06D, 06E compressors without unloading. With the exception of the 06D 2-cylinder models, these packages can be added to any new, replacement, or existing 06D or 06E compressors. See Fig. 25.

NOTE: Before adding a suction cut-off control package to a compressor currently without unloading, consider all line piping sizes and design to ensure proper oil return to compressor with reduced (unloaded) refrigerant flow rates.

CAPACITY CONTROL PACKAGES

CAPACITY CONTROL PACKAGES

COMPRESSOR	TYPE	COLOR	PACKAGE NUMBER	BARE UNLOADER VALVE
06D	Electric	Green	06DA660177*	06DA660175
		Gray	06DA660180	
	Pressure	Green	06DA660090	06DA660176 †
		Gray	06DA660181	
06E	Electric	Green	06EA660171*	06DA660175
		Gray	06EA660173	
	Pressure	Green	06EA660139	06DA660176 †
		Gray	06EA660174	

* Coil NOT included, order separately (see Section 3.16).

† Special Allen head wrench to change valve is part number 06EA680036.

NOTES:

- Each package unloads 2 cylinders (1-step) and includes (1) cylinder head assembly with applicable unloader valve (electric or pressure) and necessary gaskets.
- When adding the suction cut-off unloading feature to any compressor, it is no longer necessary to change the valve plate. The suction cut-off method of unloading functions independently of the valve plate.
- To avoid interfering with hi-lo pressure connections or cylinder head sensor, install the unloader cylinder head as follows (viewed from P.E. of compressor):
 06D 4-cyl - left hand cylinder deck
 06E 4-cyl - right hand cylinder deck
 06D, 06E 6-cyl - either cylinder deck (both when applicable)
- Unloader valve gasket part number 06EA501253.
- Unloader is not available for 06CC compressors.

SMART UNLOADING CAPACITY CONTROL PACKAGE

COMPRESSOR	TYPE	COLOR	PACKAGE NUMBER
06D*	Electric	Green	06DA409557
		Gray	06DA660182
06E*	Electric	Green	06EA407189
		Gray	06EA660175

* Does not include gaskets, bolts, and solenoid coils.

LOADED OPERATION

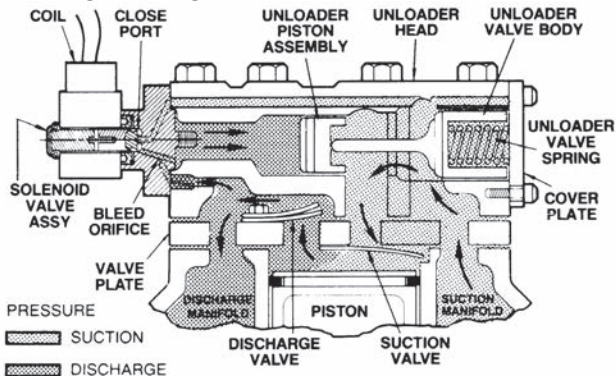

UNLOADED OPERATION

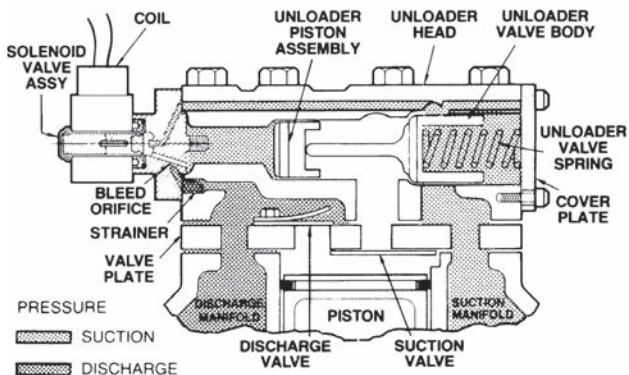

Fig. 25 — Loaded and Unloaded Operation

3.16 — Capacity Control Coil Packages (06D, E)

COIL PACKAGE PART NUMBER	VOLTAGE
EF19ZZ001	24-1-50/60
EF19ZZ002	120-1-50/60
EF19ZZ003	208/240-1-50/60

3.17 — Crankcase Heater Data

Crankcase heaters help reduce refrigerant migration to the compressor during shut-down. Crankcase heaters are designed to raise the temperature in the compressor oil compartment approximately 15 to 25°F (8 to 14°C). Carlyle recommends crankcase heaters be wired so the heater is energized only when the compressor shuts off. Crankcase heaters should be “ON” initially for 24 hours before starting the compressor. All HFC/POE applications require a crankcase heater.

STRAP-ON HEATERS:

Mounted externally to the underside of the stamp steel bottom plate. Install axially using (2) bottom plate bolts plus brackets and screws in package. Used on 06D()808, 109, 013, 313, and 316 compressors. All strap-on heaters are 50 watts.

INSERTION HEATERS:

Insert into cast well (hole) in cast iron bottom plate. Circular clip with barbs secures heater. Used on 06D()718, 818, and 820 4-cylinder compressors, all 6-cylinder 06D compressors, all 06E and all 06CC compressors. Insertion heaters are available in 125 and 180 watt sizes.

CRANKCASE HEATER PACKAGES

CRANKCASE HEATER PACKAGE	TYPE	HEATER NUMBER	VOLTAGE	WATTS	CONDUIT LENGTH in. (cm)	WIRE LENGTH in. (cm)
06DA660091	Strap-on	HT33AK300	115	50	24 (61)	39 (99)
06DA660092	Strap-on	HT33BK310	230	50	24 (61)	39 (99)
06EA660165	Insertion	HT36DM132	115	180	19 (48)	24 (61)
06EA660167	Insertion	HT36DM134	115	180	52 (132)	73 (185)
06EA660166	Insertion	HT36DM432	230	180	19 (48)	24 (61)
06EA660168	Insertion	HT36DM434	230	180	52 (132)	73 (185)
06DA660076	Insertion	HT36DL480	480	125	—	24 (61)

NOTES:

1. Insertion heaters use AS8IVF056 tubular clip.
2. Thermal grease is provided and must be used with 180 watt heaters (grease packet PN 38AQ680001).

3.18 — Compressor Mounting Data

Mounting packages are available to mount individual compressors. Package contains mounting springs, threaded studs, snubbers, spring cups, nuts, and washers for (1) compressor.

MOUNTING PACKAGE NUMBER	USE WITH BODY STYLE
06DA660058	06d 2-cyl
06DA660056	06D 4-cyl
06DA660057	06D, 06CC (16 to 41 Cfm) 6-cyl
06EA660089	06E 4 and 6-cyl and 06CC (50 to 99 Cfm)

COMPRESSOR MOUNTING PLATE PACKAGE

No. 06EA660096

This universal mounting plate will accommodate any size 06D, 06E, and 06CC compressor. Mount plate to existing base and mount the Carlyle compressor to the plate. Package includes pre-drilled mounting plate, spacers, and template.

3.19 — Compressor Service Valves (06D, E, CC)

VALVE PACKAGE NO.*	ODS (in.)	BOLT HOLE SPACING (in.)	VALVE NUMBER
06DA660060	5/8 brass	1-5/8	EN32AA250
06DA660061	7/8 brass	1-5/8	EN07AA271
06DA660062	7/8 brass	1-3/4	EN07AA284
06DA660063	1-1/8 brass	2-1/2 sq.	EN07EA033
06DA660064	1-1/8 brass	1-3/4	EN07AA348
06DA660065	1-3/8 brass	2-1/2 sq.	EN07EA039
06EA660090	1-5/8 brass	2-1/2 sq.	EN07EA041
06EA660164	2-1/8 brass	3-1/16 sq.	EN07EA510

* Valve packages consist of (1) service shut-off valve and required gasket and mounting bolts.

3.20 — Service Valve Gaskets (06D, E, CC)

DESCRIPTION	FIBER VALVE GASKET PACKAGE*	METAL VALVE GASKET PACKAGE
2-bolt 1-5/8-in. spacing	6D23-1421	06DA504143
2-bolt 1-3/4-in. spacing	6D40-1131	06DA504163
4-bolt 2-1/2-in. spacing	6D68-1131	06DA504153
Circular, No Holes	6G65-1061	—

* Service package contains 12 gaskets.

3.21 — Oil Drain Plug Adapter

All new compressors, except for 06D()808, 109, 013, 313, and 316 models, are built with a 7/16-20 SAE fitting and O-ring as the oil drain plug. Carlyle offers an oil drain adapter, P/N DE14CA126, which replaces the SAE plug. This adapter allows the installation of a 1/4 in. NPT angle valve as a drain fitting.

3.22 — Sight Glass Adapters for Oil Equalization

ADAPTER PACKAGE P/N	COMPRESSOR USAGE
06DA900072 06EA660127	For 06D and 06CC (16 to 37 Cfm) For 06E and 06CC (50 to 99 Cfm)

3.23 — Replacement Sight Glass/Installation Tool

SIGHT GLASS PACKAGE/ INSTALLATION TOOL	COMPRESSOR USAGE
5F20-152 Sight Glass (S.G.)* KM39BN010 (S.G. without O-ring) KK71GW015 (O-ring for S.G.) T133300B-1 (Installation Tool)	All 06Ds and 06CC (16 to 37 Cfm) All 06Es and 06CC (50 to 99 Cfm) All 06Es and 06CC (50 to 99 Cfm) All 06Ds and 06CC (16 to 37 Cfm)

* 5F20-152 sight glass assembly includes 5F20-1631 gasket.

3.24 — Replacement Motor End Mounting Foot

MOTOR END FOOT P/N	COMPRESSOR USAGE	MOUNTING HOLE WIDTH (in.)
6D40-1042	All 2 cylinder 06D All 4 cyl. 13 and 16 Cfm 06D All 6 cyl. 06DA A/C duty models	8.875
6D48-2063	All 4 cyl. 18 and 20 Cfm 06D	8.25
06EA500052	All 4 cyl. 06DR and DM and 06CC (16 to 37 Cfm "D" Body) All 06EA A/C duty models	8.875 and 11.375
06EA501172	06CC (50 to 99 Cfm "E" Body) and All 06ER/EM Refrig. duty models	8.875 and 11.375

3.25 — Gaskets - Cylinder Head and Valve Plate

GASKET TYPE	PART NUMBER
06D COMPRESSORS	
1: Cylinder head gaskets <ul style="list-style-type: none"> a. Side bank, no unloading b. Side bank, with unloading (suction cut-off design) c. Side bank, with unloading (hot gas bypass design) d. Center bank 2: Valve plate gaskets <ul style="list-style-type: none"> a. Standard 2" diameter cylinder bore b. Old design 1-13/16" diameter cylinder bore c. Blank-off (special) used only on old standard 16 Cfm models with suction valve at P.E. and using H.E. valve plates 	05GA502213 05GA502223 05GA502183 05GA502173 05DA500153 6D40-1073 06DA502923
06E COMPRESSORS	
1: Cylinder head gaskets <ul style="list-style-type: none"> a. Side bank, no unloading b. Side bank, with unloading (suction cut-off design) c. Side bank, with unloading (hot gas bypass design) d. Center bank 2: Valve plate gaskets <ul style="list-style-type: none"> a. H.E., low temperature (ER, EY) 0.028"/0.036" b. H.E., medium temperature (EM, EZ) 0.067"/0.072" c. H.E., high temperature (EA, ET) 0.067"/0.072" d. Old standard, low temperature (ER, EY) 0.035"/0.041" e. Old standard, medium temperature (EM, EZ) 0.035"/0.041" f. Old standard, high temperature (EA, EX) 0.067"/0.072" 	06EA503304 06EA503334 06EA503314 06EA503314 Package #06ER660012 contains: (1) 06EA501853 gasket/ (2) suction valves 06EA504884 (fiber) or 06EA506414 (metal) 06EA506418 06ER660012 06ER660012 06EA504884
06CC COMPRESSORS	
16 to 37 Cfm <ul style="list-style-type: none"> a. Cylinder head b. Valve plate c. Suction manifold d. Interstage manifold e. Liquid injection f. Interstage tube 50 to 99 Cfm <ul style="list-style-type: none"> a. Cylinder head b. Valve plate c. Suction manifold d. Interstage manifold e. Liquid injection f. Interstage tube 	05GA502213 05DA500153 6D40-1131* 6D40-1131* 6D23-1421* 6D23-1421* 06EA503334 06EA506414 6D68-1131* 6D68-1131* 6D23-1421* 6D68-1131*

* Service package contains 12 gaskets.

NOTE: "H.E." and "Old Standard" are designations based on date of manufacture; see Section 3.4 page 68 for details.

3.26 — Miscellaneous

Terminal Plate Gasket

COMPRESSOR USAGE	GASKET
06D, 06CC (16 to 37 Cfm) 06E, 06CC (50 to 99 Cfm)	6D40-1061 6G45-1082

Sensor Block Gasket

COMPRESSOR USAGE	GASKET
06D, 06E, 06CC	06DA504473

Electrical Terminal Barrel Nut Tool (Socket tool used for installation for terminal nuts)

COMPRESSOR USAGE	GASKET
All 06D, 06CC (16 to 37 Cfm)	P920-0009

3.27 — Valve Plate Packages, Service Replacement

Carlyle began installing high efficiency valve plates in the mid 1980s. With a few exceptions noted, the valve plates fit all current and older Carlyle compressors. Check notes below the table for exceptions.

COMPRESSOR USAGE	VALVE PLATE PACKAGE
06D, 06CC (17 to 41 Cfm) Compressors	
a. 06DR (if using 06DR013 or 06DR316 models see note 2)	06DA660151
b. 06DM, DA (if using 06DM313, or 06DM316 models see note 2)	06DA660152
c. 06CC (16 to 37 Cfm) low stage valve package	06CY660002
d. 06CC (16 to 37 Cfm) high stage valve package	06DA660152
06E, 06CC (50 to 99 Cfm) Compressors	
a. 06ER	06EA660143
b. 06EM, EA	06EA660137
c. 06CC (50 to 99 Cfm) low stage valve*	06EA660159
d. 06CC (50 to 99 Cfm) high stage valve	06EA660137

* Includes relief valve for both low stage banks.

NOTES:

- Carlyle recommends the 06ER660017 service replacement valve plate kit for all 06ER compressors in low temperature environmental chamber applications (see Note 6, below).
- All high efficiency (units with a "3" in the 11th digit of the model number) 06DR013 and 06DM313, 06DR316, and 06DM316 models have a 2" diameter cylinder bore and use the above valve plate kits. Older 13 and 16 cfm (prior to 1985) models have a 1-13/16" diameter bore and cannot use these valve plate kits. Kits for these models are no longer available. Suction reed valve (part no. 6D45-1072) and discharge reed valve (part no. 6D75-1062) can be used for valve plate field repair.
- Hot gas bypass unloading requires a special valve plate kit with gaskets as follows:

06D.....06DA660131

06E.....06EA660105

The Carlyle recommended suction cut-off unloading does not require a special valve plate. Suction cutoff unloading uses the standard high efficiency valve plate kit, which includes the needed gasket.

4. Service valve plate kits include:

(1) valve plate assembly, (2) suction reed valves, (3) cylinder head gaskets (side, center and suction gas unloading), (1) valve plate gasket; and for 06D compressors there are (2) suction valve position springs.

5. All new high efficiency 06DM, 06DA, and 06CC (16 to 37 Cfm) compressors have flat top pistons. All new high efficiency 06DR and 06ER compressors have one step contoured pistons. All new high efficiency 06EM, 06EA, and 06CC (50 to 99 Cfm) compressors have two-step contoured pistons.

6. The outer edges of the valve plates have "ears" that are visible when installed on the compressor. All new high efficiency valve plates have one elongated "ear" versus one or two rounded "ears" on the older standard efficiency valve plates. Note the valve plate supplied in package 06ER660017 for environmental chambers has two rounded ears.

3.28 — Muffler Recommendations

Mufflers can reduce discharge gas pulsation and effectively eliminate vibration problems downstream. They should be placed as close to the compressor as possible to maximize efficiency and minimize vibration. Mufflers should be:

- used on all 06E 66 and 99 Cfm compressor models.
- used on all 06E compressors with capacity control.
- considered for use with all 06D 37 and 41 Cfm compressor models.
- considered for use with all 06D 6-cylinder compressors with capacity control.

MUFFLER PART NO.	WEIGHT LB (KG)	INLET/OUTLET (in.)	COMPRESSOR SIZED BY Cfm
06DA605594	5 (2.3)	5/8 ODM	08, 09, 13, 16
06DA605604	5 (2.3)	7/8 ODF	18, 20, 24
06DA605614	5 (2.3)	1-1/8 ODF	28, 37, 41
06EA500302	10 (4.5)	1-3/8 ODF	50
LM10HH100	6 (2.7)	1-3/8 ODF	65, 75, and 06E()399
06EA500712	7 (3.2)	1-5/8 ODF	06E()499, 599, and 06CC899

Mufflers can be mounted horizontally or vertically.

3.29 — Electrical Accessories

TERMINAL BOX PACKAGE - This consists of terminal box, cover, and necessary mounting components.

TERMINAL BOX PACKAGE NUMBER	TYPE	COMPRESSOR USAGE AND SIZE
06DA660078	Drawn Steel	All 06D 2-cyl. (6" x 5-3/4") (15.2 x 14.6 cm)
06DA660075	Fabricated	All 06D 4-cyl. (6" x 5") (15.2 x 12.7 cm)
06DA660150	Fabricated	All 06D 6-cyl. and 06CC 16 to 37 Cfm (6" x 8") (15.2 x 20.3 cm)
06EA660095	Drawn Steel	All 06E 4 and 6-cyl. compressors and 06CC 50 to 99 Cfm (7" x 7") (17.8 x 17.8 cm)

TERMINAL LUG PACKAGE - The 06DA660095 package consists of six, screw-on terminal lugs with set screws. The HY85TB004 and HY85TB008 packages consist of one terminal lug (six required per compressor).

TERMINAL LUG PACKAGE NUMBER	COMPRESSOR USAGE
06DA660095	All 06D and 06CC 16 to 41 Cfm
HY85TB008	All 06E and 06CC 50 to 99 Cfm #4 to #8 Wire Size
HY85TB004	All 06E and 06CC 50 to 99 Cfm #1 to #4 Wire Size

TERMINAL PLATE JUMPER PACKAGE FOR 06E, 06CC 50 TO 99 Cfm - This package consists of jumper bars, terminal nuts and instructions to interconnect terminal studs for proper motor starting (PW or XL) and voltage.

JUMPER PACKAGE NUMBER	USAGE
06EA660141	208/230/460 (triple voltage)
06EA660097	208/230/460/575 (distinct voltage)

NOTE: With 06E multi-volt (208/230/460) compressors, the 460-volt motor can be connected only for across-the-line start. A compressor with a distinct 460-volt motor (or designated P/W) must be used for part-winding start.

3.30 — Baffle Plate Recommendations

Baffle plates can be used to reduce compressor discharge gas pulsations. Recommended baffle plate assemblies are shown below. These plates are designed to create a 6 to 10 psi (0.4 to 0.7 Bars) pressure drop in the discharge gas. Use only the baffle plate recommended for the application.

These baffle plates, sandwiched between two gaskets, are installed between the compressor discharge service valve and the compressor crankcase or cylinder head. For further details, see Carlyle OEM Bulletins No. 118 and 119.

COMPRESSOR	APPLICATION	BAFFLE PLATE PART NUMBER*
06D-13, 16, and 20 Cfm 06D-24, 25, 28, 37 and 41 Cfm 06D-24, 25, 28, 37 Cfm and all 06CC 16 to 37 Cfm	low and medium temperature low temperature only† medium temperature and 06CC	06DA660103 06DA660104 06DA660105
06E-50 Cfm 06E-65 to 75 Cfm and all 06CC 50 to 75 Cfm 06E and 06CC 99 Cfm 06E and 06CC 99 Cfm	low and medium temperature low and medium temperature low temperature medium temperature	06DA660105 06EA660145 06EA660145 06EA660170

* Includes baffle plate and 2 gaskets.

† For single-stage application. When using as booster application, use medium temperature baffle plate.

3.31 — Interstage Pressure Tables (06CC Compressors Only)

All 06CC compressors are a two-stage design. Therefore, the pressure measurements are suction, interstage, and discharge. The following tables list the interstage pressures using R-22, R-407A and R-404A/507 refrigerants.

R-22 APPROXIMATE INTERSTAGE PRESSURE ± 10 psi (0.7 BAR) WITH SUBCOOLER

Saturated Suction Temp., F (C)	Suction Pressure PSIG (BAR)	Saturated Condensing Temperature, F (C)									
		60 (16)	70 (21)	80 (27)	90 (32)	100 (38)	110 (43)	120 (49)	130 (54)		
		Condensing Pressure, PSIG (BAR)									
		101.6 (8.02)	121.4 (9.39)	143.6 (10.92)	168.4 (12.63)	195.9 (14.52)	226.4 (16.63)	259.9 (18.94)	296.8 (21.48)		
-60 (-51)	11.9* (0.611)	17 (2.19)	20 (2.39)	23 (2.60)	26 (2.81)	28 (2.94)	31 (3.15)	35 (3.43)	38 (3.63)		
-55 (-48)	9.2* (0.702)	20 (2.39)	23 (2.60)	25 (2.73)	29 (3.01)	32 (3.22)	35 (3.42)	38 (3.63)	42 (3.91)		
-50 (-45)	6.1* (0.807)	22 (2.53)	25 (2.73)	28 (2.94)	32 (3.22)	35 (3.42)	38 (3.63)	42 (3.91)	46 (4.19)		
-45 (-43)	2.7* (0.922)	25 (2.73)	28 (2.94)	31 (3.15)	35 (3.42)	38 (3.63)	42 (3.91)	46 (4.19)	50 (4.46)		
-40 (-40)	0.5 (1.05)	27 (2.88)	31 (3.15)	34 (3.36)	38 (3.63)	42 (3.91)	46 (4.19)	50 (4.46)	54 (4.73)		
-35 (-37)	2.6 (1.19)	30 (3.08)	34 (3.36)	38 (3.63)	42 (3.91)	46 (4.19)	50 (4.46)	54 (4.73)	59 (5.08)		
-30 (-34)	4.9 (1.35)	33 (3.29)	37 (3.57)	41 (3.84)	45 (4.12)	50 (4.46)	54 (4.73)	59 (5.08)	63 (5.36)		
-25 (-32)	7.4 (1.52)	36 (3.50)	40 (3.77)	44 (4.05)	49 (4.39)	54 (4.73)	58 (5.01)	63 (5.36)	68 (5.70)		
-20 (-29)	10.1 (1.71)	39 (3.70)	43 (3.98)	48 (4.32)	53 (4.67)	58 (5.01)	63 (5.36)	68 (5.70)	73 (6.05)		
-15 (-26)	13.2 (1.92)	42 (3.91)	47 (4.26)	52 (4.60)	57 (4.94)	62 (5.29)	67 (5.63)	73 (6.05)	79 (6.46)		
-10 (-23)	16.5 (2.15)	46 (4.19)	50 (4.46)	56 (4.88)	61 (5.22)	66 (5.57)	72 (5.98)	78 (6.39)	84 (6.81)		

* Indicates Vacuum - Inches of Hg.

NOTE: 1 BAR = 100 kPa or 1 ATM (Atmosphere) Pressure.

R-407A APPROXIMATE INTERSTAGE PRESSURE ± 10 psi (0.7 BAR) WITH SUBCOOLER

Saturated Suction Temp., F (C)	Suction Pressure PSIG (BAR)	Saturated Condensing Temperature, F (C)									
		60 (16)	70 (21)	80 (27)	90 (32)	100 (38)	110 (43)	120 (49)	130 (54)		
		Condensing Pressure, PSIG (BAR)									
		125.2 (8.63)	148.8 (10.26)	175.3 (12.09)	204.8 (14.12)	237.6 (16.38)	273.9 (18.88)	314 (21.65)	357.9 (24.68)		
-60 (-51)	14.5* (0.52)	8 (1.5)	10 (1.7)	11 (1.8)	12 (1.8)	13 (1.9)	15 (2.0)	19 (2.3)	36 (2.8)		
-55 (-48)	11.9* (0.61)	10 (1.7)	13 (1.9)	14 (2.0)	15 (2.1)	17 (2.2)	20 (2.4)	24 (2.7)	41 (3.1)		
-50 (-45)	8.9* (0.71)	12 (1.9)	15 (2.1)	18 (2.2)	19 (2.3)	21 (2.5)	24 (2.7)	29 (3.0)	45 (3.5)		
-45 (-43)	5.6* (0.82)	15 (2.0)	19 (2.3)	21 (2.5)	23 (2.6)	26 (2.8)	29 (3.0)	34 (3.3)	51 (3.8)		
-40 (-40)	2.1* (0.94)	18 (2.2)	22 (2.5)	25 (2.7)	27 (2.9)	30 (3.1)	34 (3.3)	39 (3.7)	56 (4.2)		
-35 (-37)	1.0 (1.08)	21 (2.4)	26 (2.8)	29 (3.0)	32 (3.2)	35 (3.4)	39 (3.7)	44 (4.0)	62 (4.5)		
-30 (-34)	3.3 (1.24)	25 (2.7)	30 (3.1)	34 (3.4)	37 (3.6)	40 (3.8)	44 (4.1)	49 (4.4)	67 (4.9)		
-25 (-32)	5.7 (1.41)	29 (3.0)	35 (3.4)	39 (3.7)	43 (3.9)	46 (4.2)	50 (4.5)	55 (4.8)	73 (5.4)		
-20 (-29)	8.5 (1.60)	34 (3.4)	40 (3.8)	45 (4.1)	49 (4.4)	52 (4.6)	56 (4.9)	62 (5.3)	80 (5.8)		
-15 (-26)	11.5 (1.81)	40 (3.7)	46 (4.2)	51 (4.6)	55 (4.8)	59 (5.1)	63 (5.4)	69 (5.8)	87 (6.3)		
-10 (-23)	14.9 (2.04)	46 (4.2)	53 (4.7)	59 (5.1)	63 (5.4)	67 (5.6)	71 (5.9)	77 (6.3)	94 (6.8)		

* Indicates Vacuum - Inches of Hg.

NOTE: 1 BAR = 100 kPa or 1 ATM (Atmosphere) Pressure.

R-404A/R507 APPROXIMATE INTERSTAGE PRESSURE ± 10 psi (0.7 BAR) WITH SUBCOOLER

Saturated Suction Temp., F (C)	Suction Pressure PSIG (BAR)	Saturated Condensing Temperature, F (C)																
		60 (16)	70 (21)	80 (27)	90 (32)	100 (38)	110 (43)	120 (49)	Condensing Pressure, PSIG (BAR)									
		129.7 (9.96)	153.6 (11.61)	180.3 (13.45)	210.2 (15.51)	243.5 (17.81)	280.6 (20.37)	321.9 (23.21)	180.3 (13.45)	210.2 (15.51)	243.5 (17.81)	280.6 (20.37)	321.9 (23.21)					
-60 (-51)	5.9* (0.814)	26 (2.81)	30 (3.08)	33 (3.29)	37 (3.57)	40 (3.77)	44 (4.05)	48 (4.32)	53 (4.67)	57 (4.94)	63 (5.36)	68 (5.70)	73 (6.05)	78 (6.39)	84 (6.81)	90 (7.22)	96 (7.63)	102 (8.05)
-55 (-48)	2.3* (0.929)	29 (3.01)	33 (3.29)	37 (3.57)	40 (3.77)	44 (4.05)	48 (4.32)	53 (4.67)	57 (4.94)	62 (5.29)	68 (5.70)	73 (6.05)	78 (6.39)	84 (6.81)	90 (7.22)	96 (7.63)	102 (8.05)	
-50 (-45)	0.9 (1.08)	33 (3.29)	37 (3.57)	40 (3.77)	45 (4.19)	49 (4.39)	53 (4.67)	58 (5.01)	62 (5.29)	67 (5.63)	73 (6.05)	78 (6.39)	84 (6.81)	90 (7.22)	96 (7.63)	102 (8.05)		
-45 (-43)	3.1 (1.23)	35 (3.43)	39 (3.70)	44 (4.05)	48 (4.32)	53 (4.67)	58 (5.01)	62 (5.29)	67 (5.63)	73 (6.05)	78 (6.39)	84 (6.81)	90 (7.22)	96 (7.63)	102 (8.05)			
-40 (-40)	5.5 (1.39)	39 (3.70)	44 (4.05)	48 (4.32)	53 (4.67)	58 (5.01)	62 (5.29)	67 (5.63)	73 (6.05)	78 (6.39)	84 (6.81)	90 (7.22)	96 (7.63)	102 (8.05)				
-35 (-37)	8.2 (1.58)	43 (3.98)	47 (4.26)	52 (4.60)	57 (4.94)	62 (5.29)	67 (5.63)	73 (6.05)	78 (6.39)	84 (6.81)	90 (7.22)	96 (7.63)	102 (8.05)					
-30 (-34)	11.1 (1.78)	46 (4.19)	51 (4.53)	56 (4.88)	61 (5.22)	67 (5.63)	73 (6.05)	78 (6.39)	84 (6.81)	90 (7.22)	96 (7.63)	102 (8.05)						
-25 (-32)	14.3 (2.00)	50 (4.46)	55 (4.81)	60 (5.15)	66 (5.57)	72 (5.98)	78 (6.39)	84 (6.81)	90 (7.22)	96 (7.63)	102 (8.05)							
-20 (-29)	17.8 (2.24)	54 (4.74)	59 (5.08)	65 (5.50)	71 (5.91)	77 (6.32)	83 (6.74)	89 (7.15)	95 (7.57)	102 (8.05)								
-15 (-26)	21.7 (2.51)	58 (5.01)	64 (5.43)	70 (5.84)	76 (6.26)	82 (6.67)	89 (7.15)	95 (7.57)	102 (8.05)									
-10 (-23)	25.8 (2.79)	62 (5.29)	68 (5.70)	74 (6.12)	81 (6.60)	88 (7.08)	95 (7.57)	102 (8.05)										

* Indicates Vacuum - Inches of Hg.

NOTE: 1 BAR = 100 kPa or 1 ATM (Atmosphere) Pressure.

4.0 — ELECTRICAL DATA

4.1 — 06DR 3 Phase Electrical Specifications

		NEW HIGH EFFICIENCY MODELS						OLD STANDARD EFFICIENCY MODELS					
Compressor Model*	Volt	MCC	Electrical Data			HP	Compressor Model*	Volt	MCC	Electrical Data		LRA	LRA
			RLA	LRA	Motor Winding Resistance (Ohms)					MAX (kW)	RLA		
06DR1090GA3150 GA3250 GA3650	575	4.4	2.8	21.3	7.0	2	06DR1090GC2100 GA1200 GA2600	575	3.9	-	21.3	21.3	
	208/230	12.1	7.6	53.3	1.1			12.1	12.1	8.6	8.6	53.3	53.3
	460	5.5	3.5	26.3	4.4			3.9	3.9	5.5	5.5	26.3	26.3
06DR0130CA3150 CA3250 CA3250 CA3650	575	7	4.5	28.4	5.0	3	06DR0130FA0100 FA0400 FA0500 FA0600	575	5.9	4.2	23	23	
	208/230	17.4	11.2	71	0.81			17	12.1	17	17	63.5	63.5
	208/230	17.4	11.2	71	0.81			14.8	10.6	14.8	14.8	57.5	57.5
460	8.7	5.6	35.5	3.2	3.2	7.4	5.3	7.4	7.4	28.8	28.8		
06DR3160CA3150 CA3250 CA3250 CA3600	575	10.8	6.9	40	3.3	5	06DR3160FA0110 FA0410 FA0510 FA0610	575	9.4	6.7	34.5	34.5	
	208/230	27	17.3	100	0.54			27	19.3	27	27	95	95
	208/230	27	17.3	100	0.54			23.5	16.8	23.5	23.5	86	86
460	13.5	8.6	50	2.1	2.1	11.8	8.4	11.8	11.8	43	43		
06DR7180DA3150 DA3250 DA3250 DA3650	575	10.8	6.9	40	3.3	5	06DR7180DA0110 DA0410 DA0510 DA0610	575	9.4	6.7	34.5	34.5	
	208/230	27	17.3	100	0.54			27	19.3	27	27	95	95
	208/230	27	17.3	100	0.54			23.5	16.8	23.5	23.5	86	86
460	13.5	8.6	50	2.1	2.1	11.8	8.4	11.8	11.8	43	43		
06DR8200DA3150 DA3250 DA3650	575	17.6	11.3	64	2.6	6.5	06DR8200DA0100 DA1200 DA0600	575	17.6	12.6	50	50	
	208/230	44	28.2	160	0.42			48.8	34.9	48.8	48.8	137	137
	460	22	14.1	80	1.7			22	15.7	22	22	62	62

NEW HIGH EFFICIENCY MODELS				OLD STANDARD EFFICIENCY MODELS								
Compressor Model*	Electrical Data						HP	Compressor Model*	Electrical Data			
	Volt	MCC	RLA	LRA	Motor Winding Resistance (Ohms)	MAX (kW)			Volt	MCC	RLA	LRA
06DR7420DA3150 DA3250 DA3650	575 208/230 460	17.6 44 22	11.3 28.2 14.1	64 160 80	2.6 0.42 1.7	9.8	6.5	06DR7240DA0100 DA1200 DA0600	575 208/230 460	17.6 48.8 22	12.6 34.9 15.7	50 137 62
06DR7250DA3150 DA3250 DA3650	575 208/230 460	17.6 44 22	11.3 28.2 14.1	64 160 80	2.6 0.42 1.7	9.8	6.5	06DR7240DA0100 DA1200 DA0600	575 208/230 460	17.6 48.8 22	12.6 34.9 15.7	50 137 62
06DR2280DA3150 DA3250 DA3650	575 208/230 460	22.2 55.5 27.8	14.2 35.6 17.8	79 198 99	2.0 0.31 1.3	12.8	7.5	06DR2280DA0100 DA1200 DA0600	575 208/230 460	22.2 55.5 27.8	15.9 43.9 19.9	62 170 77
06DR3370DA3150 DA3250 DA3650	575 208/230 460	25 62 31	16.0 39.7 19.9	91 228 114	1.7 0.26 1.0	16.5	10	06DR3370DA0100 DA1200 DA0600	575 208/230 460	25 69 31	17.9 49.3 22.1	69 191 86
06DR5410DA0150 DA1250 DA0650	575 208/230 460	32 89 40	20.5 57.1 25.6	61 266 120	1.2 0.18 0.72	20.7	15					

Not Applicable

LEGEND

LRA – Locked Rotor Amps

MCC – Maximum Continuous Current

RLA – Rated Load Amps

* The last two digits of the compressor model number may vary. See page 3.

NOTES:

1. RLA (rated load amps) value shown for new high efficiency models is $MCC \div 1.56$ - RLA. Use this recommended (and minimum) RLA value to determine nameplate stamping, minimum contactor sizing and wire sizing.

2. Compressor operating amps at any specific conditions can only be determined from a performance curve.

3. RLA values for 06D compressor protected by a calibrated circuit breaker will depend on must-trip value of circuit breaker.

4. Ohm values shown for resistance are approximate and shown for reference only. Motors from different vendors and motors of different efficiencies can differ up to 15% from data shown.

ALLOWABLE OPERATING RANGES

NOMINAL VOLTAGE	MAXIMUM	MINIMUM
208/230	254	187
460	529	414
575	661	518
400 (50 Hz)	460	342
200 (50 Hz)	230	180

4.2 — 06DM, DA 3 Phase Electrical Specifications

NEW HIGH EFFICIENCY MODELS							OLD STANDARD EFFICIENCY MODELS					
Compressor Model*	Volt	MCC	RLA	LRA	Electrical Data		HP	Compressor Model*	Volt	MCC	RLA	LRA
					Motor Winding Resistance (Ohms)	MAX (kW)						
06DM												
06DM8080GA3150	575	7	4.5	28.4	5.0	3	06DM8080GC0120	575	5.9	5.9	-	23
GA3250	208/230	17.4	11.2	71	0.78	4.1	GC0430	200	17.0	17.0	12.1	63.5
GA3250	208/230	17.4	11.2	71	0.78		GA0520	230	14.8	14.8	10.6	57.5
GA3650	460	8.7	5.6	28.8	3.1		GA0620	460	7.4	7.4	5.3	28.8
06DM3130CA3150	575	10.8	6.9	40	3.3	5	06DM3130FA0120	575	9.4	9.4	6.7	34.5
CA3250	208/230	27	17.3	100	0.5	6.25	FA0420	200	27.0	27.0	19.3	95
CA3250	208/230	27	17.3	100	0.5		FA0520	230	23.5	23.5	16.8	86
CA3600	460	13.5	8.6	50	2.1		FA0620	460	11.8	11.8	8.4	43
06DM3160CA3150	575	10.8	6.9	40	3.3	5	06DM3160FA0120	575	9.4	9.4	6.7	34.5
CA3250	208/230	27	17.3	100	0.5	6.25	FA0420	200	27.0	27.0	19.3	95
CA3250	208/230	27	17.3	100	0.5		FA0520	230	23.5	23.5	16.8	86
CA3650	460	13.5	8.6	50	2.1		FA0620	460	11.8	11.8	8.4	43
06DM3370DA3150	575	25	16.0	61	1.7	10	06DM3370DA0120	575	25	25	17.9	69
DA3250	208/230	62	39.7	228	0.26	16.5	DA1220	208/230	69	69	49.3	191
DA3650	460	31	19.9	114	1.0		DA0620	460	31	31	22.1	86
06DA												
06DA8182AA3150	575	17.6	11.3	64	2.6	6.5	06DA8182AA0100	575	17.6	17.6	12.6	50
AA3250	208/230	44	28.2	160	0.42	9.18	AA1200	208/230	48.8	48.8	34.9	137
AA3650	460	22	14.1	80	1.7		AA0600	460	22	22	15.7	62

NEW HIGH EFFICIENCY MODELS					OLD STANDARD EFFICIENCY MODELS							
Compressor Model*	Electrical Data				HP	Compressor Model*	Electrical Data					
	Volt	MCC	RLA	LRA			Motor Winding Resistance (Ohms)	MAX (kW)	Volt	MCC	RLA	LRA
06DA (continued)												
06DA8242BA3150	575	22.2	14.2	79	2.0	12.8	7.5	06DA8242BA0100	575	22.2	15.9	62
BA3250	208/230	55.5	35.6	198	0.31			BA1200	208/230	61.5	43.9	170
BA3650	460	27.8	17.8	99	1.3			BA0600	460	27.8	19.9	77
06DA8252BA3150	575	22.2	14.2	79	2.0	12.8	7.5	N/A	N/A	N/A	N/A	N/A
BA3250	208/230	55.5	35.6	198	0.31							
BA3650	460	27.8	17.8	99	1.3							
06DA3282BA3150	575-3-60	25	16.0	91	1.7	16.5	10	06DA3282BA0100	575	25	17.9	69
BA3250	208/230	62	39.7	228	0.26			BA1200	208/230	69	49.3	191
BA3650	460	31	19.9	114	1.0			BA0600	460	31	22.1	86
06DA5372BA0150	575	32	20.5	96	1.2	20.7	15	06DA5372BA0100	575	32	22.9	96
BA1250	208/230	89	57.1	266	0.18			BA1200	208/230	89	63.6	266
BA0650	460	40	25.6	120	0.72			BA0600	460	40	28.6	120

LEGEND

LRA – Locked Rotor Amps

MCC – Maximum Continuous Current

RLA – Rated Load Amps

* The last two digits of the compressor model number may vary. See page 3.

NOTES:

1. RLA (rated load amps) value shown for new high efficiency models is MCC + 1.56 - RLA.

Use this recommended (and minimum) RLA value to determine nameplate stamping, minimum contactor sizing and wire sizing.

2. Compressor operating amps at any specific conditions can only be determined from a performance curve.

3. RLA values for 06D compressor protected by a calibrated circuit breaker will depend on must-trip value of circuit breaker.

4. Ohm values shown for resistance are approximate and shown for reference only. Motors from different vendors and motors of different efficiencies can differ up to 15% from data shown.

ALLOWABLE OPERATING RANGES		
NOMINAL VOLTAGE	MAXIMUM	MINIMUM
208/230	254	187
460	529	414
575	661	518
400 (50 Hz)	460	342
200 (50 Hz)	230	180

4.3 — 06DR, DM Single Phase Electrical Specifications

COMPRESSOR VARIABLE	COMPRESSOR MODEL			
	06DM8080CA3350*	06DR1090CA3350*	06DR0130CA3350*	06DM3130CA3350* 06DR3160CA3350*
Nominal Horsepower	3	3	3	5
Start Capacitor and PN	196 MFD @ 320 V P281-1896	196 MFD @ 320 V P281-1896	238 MFD @ 320 V P281-2166	238 MFD @ 320 V P281-2166
Run Capacitor and PN	35 MFD @ 440 V P291-3504	35 MFD @ 440 V P291-3504	40 MFD @ 440 V P291-4004	50 MFD @ 440 V P291-5004
Start Relay Data Hot Pick-Up Voltage and PN	220-24 V HN61KB021 or P283-9913	220-24 V HN61KB021 or P283-9913	260-280 V HN61KB022 or P283-9918	350-370 V P283-9912
Cold Pick-Up Voltage	208/239 V	208-239 V	239-268 V	328-356 V
Dropout Voltage	50-110 V	50-110 V	50-110 V	60-121 V
Coil Voltage	375 V	375 V	375 V	420 V
MCC	28	24	32.6	40
RLA	20	17.1	23.3	28.6
LRA	110	110	100	150
(Manufacturer Number) Common Overload	(8347A23-63) HN69GZ024	(8347A23-31) HN69GZ025	(8347A23-63) HN69GZ024	(8348A19-4) HN69GZ307
(Manufacturer Number) Start Overload	(8347A23-53) HN69GZ014	(8347A23-42) HN69GZ032	(8347A23-53) HN69GZ014	(8347A23-40) HN69GZ037

LEGEND

LRA – Locked Rotor Amps

MCC – Maximum Continuous Current

RLA – Rated Load Amps

* The last two digits of the compressor model number may vary. See page 3.

■ Information in shaded area is no longer available in standard factory production.

ALLOWABLE OPERATING RANGES

NOMINAL VOLTAGE	MAXIMUM	MINIMUM
208/230-1-60	254 V	187 V

4.4 — 06ER, EY 3 Phase Electrical Specifications

COMPRESSOR MODEL*	VOLT	MAX kW	HP	SEE NOTE 1				SEE NOTE 2		MOTOR WINDING RESISTANCE (Ohms)	SEE NOTE 3 Recommended Circuit Breaker Part No.	CIRCUIT BREAKER DATA†			SEE NOTE 4 RLA with Listed Breaker
				Maximum Must Trip Amps	Maximum RLA	LRA-XL	LRA-PW (first winding)	M.H.	M.T.			LRA			
													M.H.	M.T.	
06ER(1/4)50000 (1/4)50100 (1/4)50600 (1/4)50300	208/230			90	72	283	170	0.44	HH83XB626	78	90	250	64.3		
	575	31	98	38	31	98	59	2.8	XB634	29	33.5	97	23.9		
	460	46	142	46	44	142	85	1.8	XB695	40	46	150	33.9		
06ER(1/4)65000 (1/4)65100 (1/4)65600 (1/4)65300	208/230/460			90/46	72/36	283/142	170/85	0.44/0.22	XB626XB695	78/40	90/46	250/150	64.3/33.9		
	208/230			108	87	345	207	0.32	HH83XB625	91	104	350	74.3		
	575	36	120	45	36	120	72	2.2	XB422	33	38	124	27.1		
06ER(1/4)75000 (1/4)75100 (1/4)75600 (1/4)75300	208/230/460			108/54	87/44	345/173	207/104	0.32/0.16	XB625XB606	91/42	104/49	350/175	74.3/35		
	208/230			108	87	345	207	0.32	HH83XB625	91	104	350	74.3		
	575	36	120	45	36	120	72	2.2	XB422	33	38	124	27.1		
06ER(0/3)99000 (0/3)99100 (0/3)99600 (0/3)99300	208/230/460			168/84	135/68	506/253	304/152	0.22/0.11	XC539XB609	142/67	163/76	507/274	116.4/54.3		
	208/230			168	135	506	304	0.22	HH83XC539	142	163	507	116.4		
	575	65	176	65	52	176	106	1.3	XB683	50	58	168	41.4		
	460	84	253	84	68	253	152	0.88	XB609	65	76	274	54.3		
	208/230/460			168/84	135/68	506/253	304/152	0.22/0.11	XC539XB609	142/67	163/76	507/274	116.4/54.3		

LEGEND

- LRA – Locked Rotor Amps
- MH – Must Hold Amps
- MT – Must Trip Amps
- PW – Part Winding (Start)
- RLA – Rated Load Amps
- XL – Across-the-Line (Start)

* The last two digits of the compressor model number may vary. See page 4. The fifth digit in () of the compressor model number represents models with or without oil. 0, 1, 2 signifies older models with oil; 3, 4, 5 signifies newer models without oil. See page 4.

† Refer to revised Bulletin 03T-2 for recommended motor protection.

NOTES:

1. Compressor must-trip (M.T.) amps and RLA values are maximum figures.
2. LRA values for PW second winding = 1/2 the LRA -XL value.
3. 3-Pole XL circuit breakers shown, other 3-Pole XL alternates and 6-Pole PW breakers available. Terminal lugs for circuit breakers available in package 06EA660152.
4. RLA value shown is determined by: circuit breaker must trip value \div 1.40. Use this recommended (and minimum) RLA value to determine name plate stamping, minimum contactor sizing, and wire sizing. **RECOMMENDED RLA FOR 06E COMPRESSORS EQUALS: MUST- TRIP (M.T.) OF CARLYLE APPROVED OVERCURRENT DEVICE BEING USED \div 1.40.**
5. 06ER166 New OEM Models no longer produced, replaced by 06ER165.
6. Compressor operating amps at any specific condition can only be determined from a performance curve.
7. Ohm values for resistance are approximate and shown for reference purposes only. Motors from different vendors and motors of different efficiencies can differ up to 15% from data shown.

ALLOWABLE OPERATING RANGES

NOMINAL VOLTAGE	MAXIMUM	MINIMUM
208/230	254	187
460	529	414
575	661	518
400 (50 Hz)	460	342
200 (50 Hz)	230	180

4.5 — 06EM, EZ 3 Phase Electrical Specifications

COMPRESSOR MODEL*	COMPRESSOR MOTOR DATA					CIRCUIT BREAKER DATA†							
	VOLT	MAX KW	HP	SEE NOTE 1		SEE NOTE 2		MOTOR WINDING RESISTANCE (Ohms)	SEE NOTE 3 Recommended Circuit Breaker Part No.	M.H.	M.T.	LRA	SEE NOTE 4
				Maximum Must Trip Amps	Maximum RLA	LRA-XL	LRA-PW (first winding)						
06EM(1/4)50000 (1/4)50100 (1/4)50600 (1/4)50300	208/230 575 460 208/230/460	22.0	15	90 38 46 90/46	72 31 36 72/36	283 98 142 283/142	170 59 85 170/85	0.44 2.8 1.8 0.44/0.22	HH83XB626 XB634 XB695 XB626/XB695	78 29 40 78/40	90 33.5 46 90/46	250 97 150 250/150	64.3 23.9 33.9 64.3/33.9
06EM(2/5)65000 (2/5)65100 (2/5)65600 (See Note 5)	208/230 575 460	33.6	25	140 57 70	112 46 56	446 164 223	268 98 134	0.27 1.6 1.1	HH83XC509 XB615 XB607	110 46 55	127 53 64	420 164 210	90.7 37.9 45.7
06EM(1/4)75000 (1/4)75100 (1/4)75600 (1/4)75300	208/230 575 460 208/230/460	33.6	25	140 57 70 140/70	112 46 56 112/56	446 164 223 446/223	268 98 134 268/134	0.17 1.6 1.1 0.27/0.14	HH83XC509 XB615 XB607 XC509/XB607	110 46 55 110/55	127 53 64 127/64	420 164 210 420/210	90.7 37.9 45.7 90.7/45.7
06EM(1/4)99000 (1/4)99100 (1/4)99600 (1/4)99300	208/230 575 460 208/230/460	47.6	35	193 77 96 193/76	155 62 77 155/77	610 212 305 610/305	366 127 183 366/183	0.18 1.1 0.71 0.18/0.09	HH83XC532 XB680 XB648 XC532/XB648	158 68 77 158/77	182 78 88 182/88	590 236 283 590/283	130 55.7 62.9 130/62.9

LEGEND

- LRA – Locked Rotor Amps
- MH – Must Hold Amps
- MT – Must Trip Amps
- PW – Part Winding (Start)
- RLA – Rated Load Amps
- XL – Across-the-Line (Start)

* The last two digits of the compressor model number may vary. See page 4. The fifth digit in () of the compressor model number represents models with or without oil. 0, 1, 2 signifies older models with oil; 3, 4, 5 signifies newer models without oil. See page 4.

† Refer to revised Bulletin 03T-2 for recommended motor protection.

NOTES:

1. Compressor must-trip (M.T.) amps and RLA values are maximum figures.
2. LRA values for PW second winding = 1/2 the LRA -XL value.
3. 3-Pole XL circuit breakers shown, other 3-Pole XL alternates and 6-Pole PW breakers available. Terminal lugs for circuit breakers available in package 06EA660152.
4. RLA value shown is determined by: circuit breaker must trip value ÷ 1.40. Use this recommended (and minimum) RLA value to determine name plate stamping, minimum contactor sizing, and wire sizing. **RECOMMENDED RLA FOR 06E COMPRESSORS EQUALS: MUST- TRIP (M.T.) OF CARLYLE APPROVED OVERCURRENT DEVICE BEING USED ÷ 1.40.**
5. 06EM266 New OEM Models no longer produced, replaced by 06EA265.
6. Compressor operating amps at any specific condition can only be determined from a performance curve.
7. Ohm values for resistance are approximate and shown for reference purposes only. Motors from different vendors and motors of different efficiencies can differ up to 15% from data shown.

ALLOWABLE OPERATING RANGES

NOMINAL VOLTAGE	MAXIMUM	MINIMUM
208/230	254	187
460	529	414
575	661	518
400 (50 Hz)	460	342
200 (50 Hz)	230	180

4.6 — 06EA, ET 3 Phase Electrical Specifications

COMPRESSOR MOTOR DATA				CIRCUIT BREAKER DATA									
COMPRESSOR MODEL*	VOLT	MAX KW	HP	SEE NOTE 1		SEE NOTE 2		MOTOR WINDING RESISTANCE (Ohms)	SEE NOTE 3 Recommended Circuit Breaker Part No.	M.H.	M.T.	LRA	SEE NOTE 4 RLA with Listed Breaker
				Maximum Must Trip Amps	Maximum RLA	LRA-XL	LRA-PW (first winding)						
06EA(2/5)50000 (2/5)50100 (2/5)50600	208/230	25.3	20	108	87	345	207	0.32	HH83XB625	91	104	350	74.3
	460			36	120	72	2.2	XB422	33	38	124	27.1	
	208/230/460			44	173	1.3	XB606	42	49	175	35		
06EA(2/5)65000 (2/5)65100 (2/5)65600	208/230	33.6	25	108/54	87/44	345/173	207/104	0.32/0.16	XB625/XB606	91/42	104/49	350/175	74.3/35
	460			140	112	446	268	0.27	HH83XC509	110	127	420	90.7
	208/230/460			57	46	164	98	1.6	XB615	46	53	164	37.9
06EA(2/5)75000 (2/5)75100 (2/5)75600	208/230	39.1	30	140/70	112/56	446/223	268/134	0.27/0.14	XC509/XB607	110/55	127/64	420/210	45.7
	460			168	135	506	304	0.22	HH83XC539	142	163	507	116.4
	208/230/460			65	52	176	106	1.3	XB683	50	58	168	41.4
06EA(2/5)99000 (2/5)99100 (2/5)99600	208/230	54.0	40	168/84	135/68	506/253	304/152	0.22/0.11	XC539/XB609	142/67	163/76	507/274	54.3
	460			84	68	253	152	0.9	XB609	63	76	274	116.4/54.3
	208/230/460			236	189	690	414	0.15	HH83XC537	187	215	636	153.6
(2/5)99300	208/230/460			118	95	345	207	0.58	XB405	74	85	236	60.7
				236/118	189/95	690/345	414/207	0.15/0.07	XC537/XB405	92	106	295	75.7
										187/92	106	636/295	153.6/75.7

LEGEND

- LRA – Locked Rotor Amps
- MH – Must Hold Amps
- MT – Must Trip Amps
- PW – Part Winding (Start)
- RLA – Rated Load Amps
- XL – Across-the-Line (Start)

* The last two digits of the compressor model number may vary. See page 4. The fifth digit in () of the compressor model number represents models with or without oil. 0, 1, 2 signifies older models with oil; 3, 4, 5 signifies newer models without oil. See page 4.

† Refer to revised Bulletin 03T-2 for recommended motor protection.

NOTES:

1. Compressor must-trip (M.T.) amps and RLA values are maximum figures.
2. LRA values for PW second winding = 1/2 the LRA -XL value.
3. 3-Pole XL circuit breakers shown, other 3-Pole XL alternates and 6-Pole PW breakers available. Terminal lugs for circuit breakers available in package 06EA660152.
4. RLA value shown is determined by: circuit breaker must trip value ÷ 1.40. Use this recommended (and minimum) RLA value to determine name plate stamping, minimum contactor sizing, and wire sizing. **RECOMMENDED RLA FOR 06E COMPRESSORS EQUALS: MUST- TRIP (M.T.) OF CARLYLE APPROVED OVERCURRENT DEVICE BEING USED ÷ 1.40.**
5. Compressor operating amps at any specific condition can only be determined from a performance curve.
6. Ohm values for resistance are approximate and shown for reference purposes only. Motors from different vendors and motors of different efficiencies can differ up to 15% from data shown.

ALLOWABLE OPERATING RANGES

NOMINAL VOLTAGE	MAXIMUM	MINIMUM
208/230	254	187
460	529	414
575	661	518
400 (50 Hz)	460	342
200 (50 Hz)	230	180

4.7 — 06CC (16 to 37 Cfm) 3 Phase Electrical Specifications

COMPRESSOR MOTOR DATA

Compressor Model	MAX kW	HP	ELECTRICAL DATA					OVERLOAD CARLYLE PART NO.	PART NO. T.I. NO.
			Volt	MCC	RLA	LRA	Motor Winding Resistance (Ohms)		
06CC016J101 D101 G101	6.25	5	575	10.8	6.9	40	3.3	HN69GZ032	8347A23-42
			208/230	27	17.3	100	0.54	HN69GZ024	8347A23-63
			460	13.5	8.7	50	2.1	HN69GZ014	8347A23-53
06CC017J101 D101 G101	6.25	5	575	10.8	6.9	40	3.3	HN69GZ032	8347A23-42
			208/230	27	17.3	100	0.54	HN69GZ024	8347A23-63
			460	13.5	8.7	50	2.3	HN69GZ014	8347A23-53
06CC018J101 D101 G101	6.25	5	575	10.8	6.9	40	3.3	HN69GZ032	8347A23-42
			208/230	27	17.3	100	0.54	HN69GZ024	8347A23-63
			460	13.5	8.7	50	2.1	HN69GZ014	8347A23-53
06CC124J101 D101 G101	9.18	6.5	575	13.2	8.5	64	2.6	HN69GZ037	8347A23-40
			208/230	33	21.2	160	0.42	HN69GZ214	8347A23-9
			460	16.5	10.6	80	1.7	HN69GZ038	8347A23-18
06CC125J101 D101 G101	9.18	6.5	575	13.2	8.5	64	2.6	HN69GZ037	8347A23-40
			208/230	33	21.2	160	0.42	HN69GZ214	8347A23-9
			460	16.5	10.6	80	1.7	HN69GZ038	8347A23-18
06CC228J101 D101 G101	12.8	7.5	575	16.7	10.2	79	2.0	HN69GZ004	8347A23-19
			208/230	41.6	26.7	198	0.31	HN69GZ306	8347B23-13
			460	20.9	13.4	99	1.3	HN69GZ010	8347A23-29
06CC337J101 D101 G101	16.5	10	575	18.8	12.1	91	1.7	HN69GZ025	8347A23-31
			208/230	46.5	29.8	228	0.26	HN69GZ309	8347B23-11
			460	23.3	14.9	114	1.0	HN69GZ024	8347A23-63

LEGEND

LRA – Locked Rotor Amps
MCC – Maximum Continuous Current
RLA – Rated Load Amps

Information in shaded area is no longer available in standard factory production.

NOTES:

1. RLA (rated load amps) value shown for new high efficiency models is $MCC \div 1.56 = RLA$. Use this recommended (and minimum) RLA value to determine nameplate stamping. Minimum contactor sizing and wire sizing.
2. Compressor operating amps at any specific condition can only be determined from a performance curve.
3. RLA values for 06D compressor protected by a calibrated circuit breaker will depend on must-trip value of circuit breaker.
4. Ohm values for resistance are approximate and shown for reference purposes only. Motors from different vendors and motors of different efficiencies can differ up to 15% from data shown.

ALLOWABLE OPERATING RANGES

NOMINAL VOLTAGE	MAXIMUM	MINIMUM
208/230	254	187
460	529	414
575	661	518
400 (50 Hz)	460	342
200 (50 Hz)	230	180

4.8 — 06CC (50 to 99 Cfm) 3 Phase Electrical Specifications

COMPRESSOR MOTOR DATA					CIRCUIT BREAKER DATA*							
Compressor Model	VOLT	MAX kW	HP	SEE NOTE 1	SEE NOTE 2		MOTOR WINDING RESISTANCE (Ohms)	SEE NOTE 3	M.T.	SEE NOTE 4		
				Max. Must Trip Amps	LRA-XL	LRA-PW (First Winding)		Recomm Circuit Breaker Part No.			M.H.	LRA
06CC550F201	460			32	142	85	2.8	HH83XB414	27	32	145	23
550J201	575	22.0	15	27	98	59	1.8	XB438	23	27	86	19
550E201	203/230/460			68/32	283	170	0.44/0.22	XB455/XB414	59	68	245	49
06CC665F201	460			50	173	104	2.2	HH83XB437	43	50	176	36
665J201	575	25.3	20	38	120	72	1.3	XB461	33	38	124	27
665E201	203/230/460			100/50	345/173	207	0.32/0.16	XB376/XB437	73	85	333	61
06CC675F201	460			50	173	104	2.2	HH83XB437	43	50	176	36
675J201	575	25.3	20	33	120	72	1.3	XB422	34	40	120	29
675E201	203/230/460			100/50	345/173	207	0.32/0.16	XB378XB437	77	89	365	64
06CC899F201	460			58	253	152	1.3	HH83XB432	63	73	240	52
899J201	575	39.1	30	58	176	106	0.88	XA430	50	58	168	41
899E201	203/230/460			141/73	506/253	304	0.22/0.11	XC406/XB432	122	141	464	101

LEGEND

- LRA – Locked Rotor Amps
 MH – Must Hold Amps
 MT – Must Trip Amps
 * Refer to revised Bulletin 03T-2 for recommended motor protection.

PW – Part Winding (Start)

RLA – Rated Load Amps

XL – Across-the-Line (Start)

* Refer to revised Bulletin 03T-2 for recommended motor protection.

NOTES:

- Compressor must-trip (M.T.) amps and RLA values are maximum figures.
- RLA values for PW second winding = 1/2 the LRA-XL value.
- 3-Pole XL circuit breakers shown, other 3-Pole XL alternates and 6-Pole PW breakers available. Terminal lugs for circuit breakers available in package 06EA660152.
- RLA value shown is determined by: circuit breaker must trip value ÷ 1.40. Use this recommended (and minimum) RLA value to determine name plate stamping, minimum contactor sizing, and wire sizing. RECOMMENDED RLA FOR 06CC COMPRESSOR EQUALS: MUST-TRIP (M.T.) OF CARLYLE APPROVED OVERCURRENT DEVICE BEING USED ÷ 1.40.
- Compressor operating amps at any specific condition can only be determined from a performance curve.
- Ohm values for resistance are approximate and shown for reference purposes only. Motors from different vendors and motors of different efficiencies can differ up to 15% from data shown.

4.9 — 06D Electromechanical Overcurrent Protection

COMPRESSOR SIZE	VOLTAGE*	CARLYLE NO.	T.I. NO.	REMARKS
06DR109	208/230-1-60	HN69GZ025 HN69GZ032	8347A23-31 8347A23-42	Common Start
06DM808 06DR013	208/230-1-60	HN69GZ024 HN69GZ014	8347A23-63 8347A23-53	Common Start
06DM313 06DM316 06DR316 06DR718	208/230-1-60	HN69GZ106 HN69GZ037	8348A7-4 8347A23-40	Common Start
06DR109	208/230	HN69GZ007	8347A23-54	2 Required
	460	HN69GZ015	8347A23-92	2 Required
	575	HN69GZ011	8347A23-86	2 Required
06DM808 06DR013	208/230	HN69GZ053	8347A23-19	2 Required
	460	HN69GZ012	8347A23-56	2 Required
	575	HN69GZ012	8347A23-56	2 Required
06DM313 06DM316 06DR316 06DR718	208/230	HN69GZ024	8347A23-63	2 Required
	460	HN69GZ014	8347A23-53	2 Required
	575	HN69GZ032	8347A23-42	2 Required
06DA818 06DR820 06DR724 (25)	208/230	HN69GZ214	8348A17-9	2 Required
	460	HN69GZ038	8347A23-18	2 Required
	575	HN69GZ037	8347A23-40	2 Required
06DA824 (25) 06DR228	208/230	HN69GZ306	8348B19-13	2 Required
	460	HN69GZ010	8347A23-29	2 Required
	575	HN69GZ053	8347A23-19	2 Required
06DA328 06DM337 06DR337	208/230	HN69GZ309	8348B19-11	3 Required
	460	HN69GZ024	8347A23-63	2 Required
	575	HN69GZ025	8347A23-31	2 Required
06DA537 06DR541	208/230	HN69GZ214	8348A17-9	4 Required†
	460	HN69GZ106	8348A7-4	2 Required
	575	HN69GZ301	8347A30-69	2 Required

* Voltage is 3 phase 60 cycle, unless noted as single-phase 60 cycle.

† Two overloads in parallel in legs 1 and 3.

NOTES:

- Most 06D compressors have internal thermostat installed in motor and wire across terminals 8 and 9 at the terminal block. It trips (opens) control circuit at 221°F (105°C) and resets at 181°F (83°C).
- Based on new high efficiency (H.E.) extended voltage compressor models.
- Information in shaded area is no longer available in standard factory production.

4.10 — 06D and 06CC (16-37 Cfm) Electronic Overcurrent Protection

The latest production Carlyle 06D and 06CC (16-37 Cfm) compressors manufactured after August 2015, S/N starting with '3115', include a new electronic overcurrent protection module that interprets a signal from a PTC triplet (embedded in the stator windings) and a current transformer (located in terminal box). This module will shut down the compressor when it is operated at conditions that are not suitable.

The most significant difference between the electromechanical overcurrent protection scheme and the new electronic overcurrent protection scheme is that the new electronic module will require OEM customers to provide control voltage to the terminal box of the compressor for the compressor protection module. The electronic overcurrent protection module and current transformer are factory installed, with a preprogrammed MCC value based on the compressor model number.

Customer model number changes and service replacement kit information for both replacement and retrofit (three phase and single phase) are outlined within this section. There will be three different electronic overcurrent protection modules that may be applied to allow for control wiring in four control voltages. One of the modules is dual rated for 120 / 240 volts while the others are single-voltage rated at 24 VAC and 24 VDC. The new electronic system also requires some changes to the compressor wiring. Wiring specifications are shown in Section 4.11.

CUSTOMER MODEL NUMBER CHANGES:

The 10th digit of the 06D customer model number will indicate the rated control voltage of the electronic overcurrent protection module that is applied. Three new customer models will replace each existing 06D model. Please see the following examples of the 06D customer model number changes.

Example of 06D compressor model number change:

06DR337SD <u>A</u> 365A	→	06DR337SD <u>1</u> 365A	[120/240VAC Control Voltage]
06DR337SD <u>A</u> 365A	→	06DR337SD <u>2</u> 365A	[24VAC Control Voltage]
06DR337SD <u>A</u> 365A	→	06DR337SD <u>3</u> 365A	[24VDC Control Voltage]

The 5th digit of the 06CC customer model number model will indicate the rated control voltage of the electronic overcurrent protection module that is applied. Three new customer models will replace each existing 06CC model. Please see the following examples of the 06CC customer model number changes.

Example of 06CC compressor model number change:

06CC <u>1</u> 25D2S1	→	06CC <u>D</u> 25D2S1	[120/240VAC Control Voltage]
06CC <u>1</u> 25D2S1	→	06CC <u>E</u> 25D2S1	[24VAC Control Voltage]
06CC <u>1</u> 25D2S1	→	06CC <u>F</u> 25D2S1	[24VDC Control Voltage]

NOTE: There is no change to the compressor electrical data (LRA or MCC/RLA) with this change in motor protection.

SERVICE REPLACEMENT KITS:

The below kits are intended to service Carlyle 06D and 06CC (16-37 Cfm) compressors manufactured AFTER August 2015, S/N starting with '3115', with the factory installed electronic overcurrent protection. When selecting

the appropriate kit, please be sure to check control voltage. All kits include a replacement electronic overcurrent protection module and current transformer, with a preprogrammed MCC value based on the compressor model number. For additional information on the kit and installation, please see 99TA516180A located on the Carlyle Compressor website (www.carlylecompressor.com).

COMPRESSOR MODEL NUMBER	ELECTRONIC OVERCURRENT PROTECTION SERVICE REPLACEMENT KIT NUMBER			MCC (Amps)
	Control Voltage			
	110-220V	24V AC	24V DC	
06C * A17D ***	06DA6606DBNB0270			27.0
06C * A17G ***	06DA6606DBNB0135			13.5
06C * A17J ***	06DA6606DBNB0108			10.8
06C * A17Q ***	06DA6606DBNB0164			16.4
06C * B17D ***		06DA6606DBNC0270		27.0
06C * B17G ***		06DA6606DBNC0135		13.5
06C * B17J ***		06DA6606DBNC0108		10.8
06C * B17Q ***		06DA6606DBNC0164		16.4
06C * C17D ***			06DA6606DBND0270	27.0
06C * C17G ***			06DA6606DBND0135	13.5
06C * C17J ***			06DA6606DBND0108	10.8
06C * C17Q ***			06DA6606DBND0164	16.4
06C * D25D ***	06DA6606DBNB0440			44.0
06C * D25G ***	06DA6606DBNB0220			22.0
06C * D25Q ***	06DA6606DBNB0266			26.6
06C * E25D ***		06DA6606DBNC0440		44.0
06C * E25G ***		06DA6606DBNC0220		22.0
06C * E25Q ***		06DA6606DBNC0266		26.6
06C * F25D ***			06DA6606DBND0440	44.0
06C * F25G ***			06DA6606DBND0220	22.0
06C * F25Q ***			06DA6606DBND0266	26.6
06C * G28D ***	06DA6606DBNB0416			41.6
06C * G28G ***	06DA6606DBNB0209			20.9
06C * G28J ***	06DA6606DBNB0167			16.7
06C * G28Q ***	06DA6606DBNB0336			33.6
06C * H28D ***		06DA6606DBNC0416		41.6
06C * H28G ***		06DA6606DBNC0209		20.9
06C * H28J ***		06DA6606DBNC0167		16.7
06C * H28Q ***		06DA6606DBNC0336		33.6
06C * J28D ***			06DA6606DBND0416	41.6
06C * J28G ***			06DA6606DBND0209	20.9
06C * J28J ***			06DA6606DBND0167	16.7
06C * J28Q ***			06DA6606DBND0336	33.6

COMPRESSOR MODEL NUMBER	ELECTRONIC OVERCURRENT PROTECTION SERVICE REPLACEMENT KIT NUMBER			MCC
	Control Voltage			
	110-220V	24V AC	24V DC	(Amps)
06C * K37D ***	06DA6606DBNB0466			46.6
06C * K37G ***	06DA6606DBNB0233			23.3
06C * K37J ***	06DA6606DBNB0188			18.8
06C * K37Q ***	06DA6606DBNB0378			37.8
06C * L37D ***		06DA6606DBNC0466		46.6
06C * L37G ***		06DA6606DBNC0233		23.3
06C * L37J ***		06DA6606DBNC0188		18.8
06C * L37Q ***		06DA6606DBNC0378		37.8
06C * M37D ***			06DA6606DBND0466	46.6
06C * M37G ***			06DA6606DBND0233	23.3
06C * M37J ***			06DA6606DBND0188	18.8
06C * M37Q ***			06DA6606DBND0378	37.8
06D * 013 ** 132 **	06DA6606DBNB0174			17.4
06D * 013 ** 232 **		06DA6606DBNC0174		
06D * 013 ** 332 **			06DA6606DBND0174	
06D * 013 ** 136 **	06DA6606DBNB0087			8.7
06D * 013 ** 236 **		06DA6606DBNC0087		
06D * 013 ** 336 **			06DA6606DBND0087	
06D * 013 ** 137 **	06DA6606DBNB0105			10.5
06D * 013 ** 237 **		06DA6606DBNC0105		
06D * 013 ** 337 **			06DA6606DBND0105	
06D * 109 ** 106 **	06DA6606DBNB0055			5.5
06D * 109 ** 206 **		06DA6606DBNC0055		
06D * 109 ** 306 **			06DA6606DBND0055	
06D * 109 ** 112 **	06DA6606DBNB0121			12.1
06D * 109 ** 212 **		06DA6606DBNC0121		
06D * 109 ** 312 **			06DA6606DBND0121	
06D * 228 ** 113 **	06DA6606DBNB0336			33.6
06D * 228 ** 213 **		06DA6606DBNC0336		
06D * 228 ** 313 **			06DA6606DBND0336	
06D * 228 ** 131 **	06DA6606DBNB0222			22.2
06D * 228 ** 231 **		06DA6606DBNC0222		
06D * 228 ** 331 **			06DA6606DBND0222	
06D * 228 ** 132 **	06DA6606DBNB0555			55.5
06D * 228 ** 232 **		06DA6606DBNC0555		
06D * 228 ** 332 **			06DA6606DBND0555	
06D * 228 ** 136 **	06DA6606DBNB0278			27.8
06D * 228 ** 236 **		06DA6606DBNC0278		
06D * 228 ** 336 **			06DA6606DBND0278	
06D * 313 ** 131 **	06DA6606DBNB0108			10.8
06D * 313 ** 231 **		06DA6606DBNC0108		
06D * 313 ** 331 **			06DA6606DBND0108	
06D * 313 ** 132 **	06DA6606DBNB0270			27.0
06D * 313 ** 232 **		06DA6606DBNC0270		
06D * 313 ** 332 **			06DA6606DBND0270	

COMPRESSOR MODEL NUMBER	ELECTRONIC OVERCURRENT PROTECTION SERVICE REPLACEMENT KIT NUMBER			MCC (Amps)
	Control Voltage			
	110-220V	24V AC	24V DC	
06D * 313 ** 136 **	06DA6606DBNB0135			13.5
06D * 313 ** 236 **		06DA6606DBNC0135		
06D * 313 ** 336 **			06DA6606DBND0135	
06D * 313 ** 137 **	06DA6606DBNB0164			16.4
06D * 313 ** 237 **		06DA6606DBNC0164		
06D * 313 ** 337 **			06DA6606DBND0164	
06D * 316 ** 131 **	06DA6606DBNB0108			10.8
06D * 316 ** 231 **		06DA6606DBNC0108		
06D * 316 ** 331 **			06DA6606DBND0108	
06D * 316 ** 132 **	06DA6606DBNB0270			27.0
06D * 316 ** 232 **		06DA6606DBNC0270		
06D * 316 ** 332 **			06DA6606DBND0270	
06D * 316 ** 136 **	06DA6606DBNB0135			13.5
06D * 316 ** 236 **		06DA6606DBNC0135		
06D * 316 ** 336 **			06DA6606DBND0135	
06D * 316 ** 137 **	06DA6606DBNB0164			16.4
06D * 316 ** 237 **		06DA6606DBNC0164		
06D * 316 ** 337 **			06DA6606DBND0164	
06D * 328 ** 113 **	06DA6606DBNB0420			42.0
06D * 328 ** 213 **		06DA6606DBNC0420		
06D * 328 ** 313 **			06DA6606DBND0420	
06D * 328 ** 131 **	06DA6606DBNB0250			25.0
06D * 328 ** 231 **		06DA6606DBNC0250		
06D * 328 ** 331 **			06DA6606DBND0250	
06D * 328 ** 132 **	06DA6606DBNB0620			62.0
06D * 328 ** 232 **		06DA6606DBNC0620		
06D * 328 ** 332 **			06DA6606DBND0620	
06D * 328 ** 136 **	06DA6606DBNB0310			31.0
06D * 328 ** 236 **		06DA6606DBNC0310		
06D * 328 ** 336 **			06DA6606DBND0310	
06D * 328 ** 137 **	06DA6606DBNB0378			37.8
06D * 328 ** 237 **		06DA6606DBNC0378		
06D * 328 ** 337 **			06DA6606DBND0378	
06D * 337 ** 106 **	06DA6606DBNB0310			31.0
06D * 337 ** 206 **		06DA6606DBNC0310		
06D * 337 ** 306 **			06DA6606DBND0310	
06D * 337 ** 131 **	06DA6606DBNB0250			25.0
06D * 337 ** 231 **		06DA6606DBNC0250		
06D * 337 ** 331 **			06DA6606DBND0250	
06D * 337 ** 132 **	06DA6606DBNB0620			62.0
06D * 337 ** 232 **		06DA6606DBNC0620		
06D * 337 ** 332 **			06DA6606DBND0620	
06D * 337 ** 136 **	06DA6606DBNB0310			31.0
06D * 337 ** 236 **		06DA6606DBNC0310		
06D * 337 ** 336 **			06DA6606DBND0310	

COMPRESSOR MODEL NUMBER	ELECTRONIC OVERCURRENT PROTECTION SERVICE REPLACEMENT KIT NUMBER			MCC
	Control Voltage			
	110-220V	24V AC	24V DC	(Amps)
06D * 337 ** 137 **	06DA6606DBNB0378			37.8
06D * 337 ** 237 **		06DA6606DBNC0378		
06D * 337 ** 337 **			06DA6606DBND0378	
06D * 537 ** 101 **	06DA6606DBNB0320			32.0
06D * 537 ** 201 **		06DA6606DBNC0320		
06D * 537 ** 301 **			06DA6606DBND0320	
06D * 537 ** 106 **	06DA6606DBNB0400			40.0
06D * 537 ** 206 **		06DA6606DBNC0400		
06D * 537 ** 306 **			06DA6606DBND0400	
06D * 537 ** 112 **	06DA6606DBNB0890			89.0
06D * 537 ** 212 **		06DA6606DBNC0890		
06D * 537 ** 312 **			06DA6606DBND0890	
06D * 537 ** 113 **	06DA6606DBNB0542			54.2
06D * 537 ** 213 **		06DA6606DBNC0542		
06D * 537 ** 313 **			06DA6606DBND0542	
06D * 541 ** 101 **	06DA6606DBNB0320			32.0
06D * 541 ** 201 **		06DA6606DBNC0320		
06D * 541 ** 301 **			06DA6606DBND0320	
06D * 541 ** 106 **	06DA6606DBNB0400			40.0
06D * 541 ** 206 **		06DA6606DBNC0400		
06D * 541 ** 306 **			06DA6606DBND0400	
06D * 541 ** 109 **	06DA6606DBNB0400			40.0
06D * 541 ** 209 **		06DA6606DBNC0400		
06D * 541 ** 309 **			06DA6606DBND0400	
06D * 541 ** 112 **	06DA6606DBNB0890			89.0
06D * 541 ** 212 **		06DA6606DBNC0890		
06D * 541 ** 312 **			06DA6606DBND0890	
06D * 718 ** 131 **	06DA6606DBNB0108			10.8
06D * 718 ** 231 **		06DA6606DBNC0108		
06D * 718 ** 331 **			06DA6606DBND0108	
06D * 718 ** 132 **	06DA6606DBNB0270			27.0
06D * 718 ** 232 **		06DA6606DBNC0270		
06D * 718 ** 332 **			06DA6606DBND0270	
06D * 718 ** 136 **	06DA6606DBNB0135			13.5
06D * 718 ** 236 **		06DA6606DBNC0135		
06D * 718 ** 336 **			06DA6606DBND0135	
06D * 725 ** 106 **	06DA6606DBNB0220			22.0
06D * 725 ** 206 **		06DA6606DBNC0220		
06D * 725 ** 306 **			06DA6606DBND0220	
06D * 725 ** 131 **	06DA6606DBNB0176			17.6
06D * 725 ** 231 **		06DA6606DBNC0176		
06D * 725 ** 331 **			06DA6606DBND0176	
06D * 725 ** 132 **	06DA6606DBNB0440			44.0
06D * 725 ** 232 **		06DA6606DBNC0440		
06D * 725 ** 332 **			06DA6606DBND0440	

COMPRESSOR MODEL NUMBER	ELECTRONIC OVERCURRENT PROTECTION SERVICE REPLACEMENT KIT NUMBER			MCC (Amps)
	Control Voltage			
	110-220V	24V AC	24V DC	
06D * 725 ** 136 **	06DA6606DBNB0220			22.0
06D * 725 ** 236 **		06DA6606DBNC0220		
06D * 725 ** 336 **			06DA6606DBND0220	
06D * 725 ** 137 **	06DA6606DBNB0266			26.6
06D * 725 ** 237 **		06DA6606DBNC0266		
06D * 725 ** 337 **			06DA6606DBND0266	
06D * 808 ** 101 **	06DA6606DBNB0070			7.0
06D * 808 ** 201 **		06DA6606DBNC0070		
06D * 808 ** 301 **			06DA6606DBND0070	
06D * 808 ** 106 **	06DA6606DBNB0087			8.7
06D * 808 ** 206 **		06DA6606DBNC0087		
06D * 808 ** 306 **			06DA6606DBND0087	
06D * 808 ** 112 **	06DA6606DBNB0174			17.4
06D * 808 ** 212 **		06DA6606DBNC0174		
06D * 808 ** 312 **			06DA6606DBND0174	
06D * 816 ** 113 **	06DA6606DBNB0266			26.6
06D * 816 ** 213 **		06DA6606DBNC0266		
06D * 816 ** 313 **			06DA6606DBND0266	
06D * 816 ** 131 **	06DA6606DBNB0176			17.6
06D * 816 ** 231 **		06DA6606DBNC0176		
06D * 816 ** 331 **			06DA6606DBND0176	
06D * 816 ** 132 **	06DA6606DBNB0440			44.0
06D * 816 ** 232 **		06DA6606DBNC0440		
06D * 816 ** 332 **			06DA6606DBND0440	
06D * 816 ** 136 **	06DA6606DBNB0220			22.0
06D * 816 ** 236 **		06DA6606DBNC0220		
06D * 816 ** 336 **			06DA6606DBND0220	
06D * 818 ** 106 **	06DA6606DBNB0246			24.6
06D * 818 ** 206 **		06DA6606DBNC0246		
06D * 818 ** 306 **			06DA6606DBND0246	
06D * 818 ** 113 **	06DA6606DBNB0266			26.6
06D * 818 ** 213 **		06DA6606DBNC0266		
06D * 818 ** 313 **			06DA6606DBND0266	
06D * 818 ** 131 **	06DA6606DBNB0176			17.6
06D * 818 ** 231 **		06DA6606DBNC0176		
06D * 818 ** 331 **			06DA6606DBND0176	
06D * 818 ** 132 **	06DA6606DBNB0440			44.0
06D * 818 ** 232 **		06DA6606DBNC0440		
06D * 818 ** 332 **			06DA6606DBND0440	
06D * 818 ** 136 **	06DA6606DBNB0220			22.0
06D * 818 ** 236 **		06DA6606DBNC0220		
06D * 818 ** 336 **			06DA6606DBND0220	
06D * 820 ** 113 **	06DA6606DBNB0266			26.6
06D * 820 ** 213 **		06DA6606DBNC0266		
06D * 820 ** 313 **			06DA6606DBND0266	

COMPRESSOR MODEL NUMBER	ELECTRONIC OVERCURRENT PROTECTION SERVICE REPLACEMENT KIT NUMBER			MCC (Amps)
	Control Voltage			
	110-220V	24V AC	24V DC	
06D * 820 ** 131 **	06DA6606DBNB0176			17.6
06D * 820 ** 231 **		06DA6606DBNC0176		
06D * 820 ** 132 **			06DA6606DBND0176	
06D * 820 ** 132 **	06DA6606DBNB0440			44.0
06D * 820 ** 232 **		06DA6606DBNC0440		
06D * 820 ** 332 **			06DA6606DBND0440	
06D * 820 ** 136 **	06DA6606DBNB0220			22.0
06D * 820 ** 236 **		06DA6606DBNC0220		
06D * 820 ** 336 **			06DA6606DBND0220	
06D * 825 ** 113 **	06DA6606DBNB0336			33.6
06D * 825 ** 213 **		06DA6606DBNC0336		
06D * 825 ** 313 **			06DA6606DBND0336	
06D * 825 ** 131 **	06DA6606DBNB0222			22.2
06D * 825 ** 231 **		06DA6606DBNC0222		
06D * 825 ** 331 **			06DA6606DBND0222	
06D * 825 ** 132 **	06DA6606DBNB0555			55.5
06D * 825 ** 232 **		06DA6606DBNC0555		
06D * 825 ** 332 **			06DA6606DBND0555	
06D * 825 ** 136 **	06DA6606DBNB0278			27.8
06D * 825 ** 236 **		06DA6606DBNC0278		
06D * 825 ** 336 **			06DA6606DBND0278	

SERVICE RETROFIT KITS (THREE PHASE):

The below kits are intended to service Carlyle 06D and 06CC (16-37 Cfm) compressors manufactured BEFORE August 2015, S/N starting with '3115', with the factory installed electromechanical overcurrent protection and a three phase motor. The provided service kits are for RETROFIT of an existing compressor with the electromechanical overcurrent protection to the electronic overcurrent protection scheme. When selecting the appropriate kit, please be sure to select the required control voltage, as the retrofit module will require OEM customers to provide control voltage to the terminal box of the compressor. All kits include a replacement large folded terminal box, electronic overcurrent protection module and current transformer, with a preprogrammed MCC value based on the compressor model number. For additional information on the kit and installation, please see 99TA516184A located on the Carlyle Compressor website (www.carlylecompressor.com).

COMPRESSOR MODEL NUMBER	ELECTRONIC OVERCURRENT PROTECTION SERVICE RETROFIT (THREE PHASE) KIT NUMBER			MCC (Amps)
	Control Voltage			
	110-220V	24V AC	24V DC	
06C * 016D ***	06DA6606DBSB0270	06DA6606DBSC0270	06DA6606DBSD0270	27.0
06C * 016G ***	06DA6606DBSB0135	06DA6606DBSC0135	06DA6606DBSD0135	13.5
06C * 016J ***	06DA6606DBSB0108	06DA6606DBSC0108	06DA6606DBSD0108	10.8
06C * 017D ***	06DA6606DBSB0270	06DA6606DBSC0270	06DA6606DBSD0270	27.0
06C * 017G ***	06DA6606DBSB0135	06DA6606DBSC0135	06DA6606DBSD0135	13.5
06C * 017J ***	06DA6606DBSB0108	06DA6606DBSC0108	06DA6606DBSD0108	10.8
06C * 018D ***	06DA6606DBSB0270	06DA6606DBSC0270	06DA6606DBSD0270	27.0
06C * 018G ***	06DA6606DBSB0135	06DA6606DBSC0135	06DA6606DBSD0135	13.5
06C * 018J ***	06DA6606DBSB0108	06DA6606DBSC0108	06DA6606DBSD0108	10.8
06C * 124D ***	06DA6606DBSB0330	06DA6606DBSC0330	06DA6606DBSD0330	33.0
06C * 124G ***	06DA6606DBSB0165	06DA6606DBSC0165	06DA6606DBSD0165	16.5
06C * 124J ***	06DA6606DBSB0132	06DA6606DBSC0132	06DA6606DBSD0132	13.2
06C * 125D ***	06DA6606DBSB0440	06DA6606DBSC0440	06DA6606DBSD0440	44.0
06C * 125G ***	06DA6606DBSB0220	06DA6606DBSC0220	06DA6606DBSD0220	22.0
06C * 125J ***	06DA6606DBSB0176	06DA6606DBSC0176	06DA6606DBSD0176	17.6
06C * 228D ***	06DA6606DBSB0416	06DA6606DBSC0416	06DA6606DBSD0416	41.6
06C * 228G ***	06DA6606DBSB0209	06DA6606DBSC0209	06DA6606DBSD0209	20.9

COMPRESSOR MODEL NUMBER	ELECTRONIC OVERCURRENT PROTECTION SERVICE RETROFIT (THREE PHASE) KIT NUMBER			MCC (Amps)
	Control Voltage			
	110-220V	24V AC	24V DC	
06C * 228J ***	06DA6606DBSB0167	06DA6606DBSC0167	06DA6606DBSD0167	16.7
06C * 337D ***	06DA6606DBSB0466	06DA6606DBSC0466	06DA6606DBSD0466	46.6
06C * 337G ***	06DA6606DBSB0233	06DA6606DBSC0233	06DA6606DBSD0233	23.3
06C * 337J ***	06DA6606DBSB0188	06DA6606DBSC0188	06DA6606DBSD0188	18.8
06C * 337Q ***	06DA6606DBSB0378	06DA6606DBSC0378	06DA6606DBSD0378	37.8
06D * 013 ** A13 **	06DA6606DBSB0105	06DA6606DBSC0105	06DA6606DBSD0105	10.5
06D * 013 ** A31 **	06DA6606DBSB0070	06DA6606DBSC0070	06DA6606DBSD0070	7.0
06D * 013 ** A32 **	06DA6606DBSB0174	06DA6606DBSC0174	06DA6606DBSD0174	17.4
06D * 013 ** A36 **	06DA6606DBSB0087	06DA6606DBSC0087	06DA6606DBSD0087	8.7
06D * 109 ** A13 **	06DA6606DBSB0095	06DA6606DBSC0095	06DA6606DBSD0095	9.5
06D * 109 ** A31 **	06DA6606DBSB0044	06DA6606DBSC0044	06DA6606DBSD0044	4.4
06D * 109 ** A32 **	06DA6606DBSB0121	06DA6606DBSC0121	06DA6606DBSD0121	12.1
06D * 109 ** A36 **	06DA6606DBSB0055	06DA6606DBSC0055	06DA6606DBSD0055	5.5
06D * 109 ** A39 **	06DA6606DBSB0055	06DA6606DBSC0055	06DA6606DBSD0055	5.5
06D * 228 ** A13 **	06DA6606DBSB0336	06DA6606DBSC0336	06DA6606DBSD0336	33.6
06D * 228 ** A31 **	06DA6606DBSB0222	06DA6606DBSC0222	06DA6606DBSD0222	22.2
06D * 228 ** A32 **	06DA6606DBSB0555	06DA6606DBSC0555	06DA6606DBSD0555	55.5
06D * 228 ** A36 **	06DA6606DBSB0278	06DA6606DBSC0278	06DA6606DBSD0278	27.8
06D * 237 ** A06 **	06DA6606DBSB0278	06DA6606DBSC0278	06DA6606DBSD0278	27.8
06D * 237 ** A12 **	06DA6606DBSB0690	06DA6606DBSC0690	06DA6606DBSD0690	69.0
06D * 313 ** A13 **	06DA6606DBSB0164	06DA6606DBSC0164	06DA6606DBSD0164	16.4
06D * 313 ** A31 **	06DA6606DBSB0108	06DA6606DBSC0108	06DA6606DBSD0108	10.8
06D * 313 ** A32 **	06DA6606DBSB0270	06DA6606DBSC0270	06DA6606DBSD0270	27.0
06D * 313 ** A34 **	06DA6606DBSB0274	06DA6606DBSC0274	06DA6606DBSD0274	27.4
06D * 313 ** A36 **	06DA6606DBSB0135	06DA6606DBSC0135	06DA6606DBSD0135	13.5
06D * 316 ** A13 **	06DA6606DBSB0164	06DA6606DBSC0164	06DA6606DBSD0164	16.4
06D * 316 ** A31 **	06DA6606DBSB0108	06DA6606DBSC0108	06DA6606DBSD0108	10.8
06D * 316 ** A32 **	06DA6606DBSB0270	06DA6606DBSC0270	06DA6606DBSD0270	27.0
06D * 316 ** A34 **	06DA6606DBSB0274	06DA6606DBSC0274	06DA6606DBSD0274	27.4
06D * 316 ** A36 **	06DA6606DBSB0135	06DA6606DBSC0135	06DA6606DBSD0135	13.5
06D * 328 ** A01 **	06DA6606DBSB0250	06DA6606DBSC0250	06DA6606DBSD0250	25.0
06D * 328 ** A05 **	06DA6606DBSB0694	06DA6606DBSC0694	06DA6606DBSD0694	69.4
06D * 328 ** A06 **	06DA6606DBSB0310	06DA6606DBSC0310	06DA6606DBSD0310	31.0
06D * 328 ** A08 **	06DA6606DBSB0564	06DA6606DBSC0564	06DA6606DBSD0564	56.4
06D * 328 ** A12 **	06DA6606DBSB0690	06DA6606DBSC0690	06DA6606DBSD0690	69.0
06D * 328 ** A13 **	06DA6606DBSB0420	06DA6606DBSC0420	06DA6606DBSD0420	42.0
06D * 328 ** A31 **	06DA6606DBSB0250	06DA6606DBSC0250	06DA6606DBSD0250	25.0
06D * 328 ** A32 **	06DA6606DBSB0620	06DA6606DBSC0620	06DA6606DBSD0620	62.0
06D * 328 ** A34 **	06DA6606DBSB0505	06DA6606DBSC0505	06DA6606DBSD0505	50.5
06D * 328 ** A36 **	06DA6606DBSB0310	06DA6606DBSC0310	06DA6606DBSD0310	31.0
06D * 337 ** A01 **	06DA6606DBSB0250	06DA6606DBSC0250	06DA6606DBSD0250	25.0
06D * 337 ** A05 **	06DA6606DBSB0694	06DA6606DBSC0694	06DA6606DBSD0694	69.4
06D * 337 ** A06 **	06DA6606DBSB0310	06DA6606DBSC0310	06DA6606DBSD0310	31.0
06D * 337 ** A08 **	06DA6606DBSB0564	06DA6606DBSC0564	06DA6606DBSD0564	56.4
06D * 337 ** A12 **	06DA6606DBSB0690	06DA6606DBSC0690	06DA6606DBSD0690	69.0

COMPRESSOR MODEL NUMBER	ELECTRONIC OVERCURRENT PROTECTION SERVICE RETROFIT (THREE PHASE) KIT NUMBER			MCC
	Control Voltage			
	110-220V	24V AC	24V DC	(Amps)
06D * 337 ** A13 **	06DA6606DBSB0378	06DA6606DBSC0378	06DA6606DBSD0378	37.8
06D * 337 ** A31 **	06DA6606DBSB0250	06DA6606DBSC0250	06DA6606DBSD0250	25.0
06D * 337 ** A32 **	06DA6606DBSB0620	06DA6606DBSC0620	06DA6606DBSD0620	62.0
06D * 337 ** A34 **	06DA6606DBSB0582	06DA6606DBSC0582	06DA6606DBSD0582	58.2
06D * 337 ** A36 **	06DA6606DBSB0310	06DA6606DBSC0310	06DA6606DBSD0310	31.0
06D * 537 ** A01 **	06DA6606DBSB0320	06DA6606DBSC0320	06DA6606DBSD0320	32.0
06D * 537 ** A05 **	06DA6606DBSB0800	06DA6606DBSC0800	06DA6606DBSD0800	80.0
06D * 537 ** A06 **	06DA6606DBSB0400	06DA6606DBSC0400	06DA6606DBSD0400	40.0
06D * 537 ** A08 **	06DA6606DBSB0750	06DA6606DBSC0750	06DA6606DBSD0750	75.0
06D * 537 ** A12 **	06DA6606DBSB0890	06DA6606DBSC0890	06DA6606DBSD0890	89.0
06D * 537 ** A13 **	06DA6606DBSB0542	06DA6606DBSC0542	06DA6606DBSD0542	54.2
06D * 537 ** A31 **	06DA6606DBSB0320	06DA6606DBSC0320	06DA6606DBSD0320	32.0
06D * 537 ** A32 **	06DA6606DBSB0890	06DA6606DBSC0890	06DA6606DBSD0890	89.0
06D * 537 ** A36 **	06DA6606DBSB0400	06DA6606DBSC0400	06DA6606DBSD0400	40.0
06D * 541 ** A01 **	06DA6606DBSB0320	06DA6606DBSC0320	06DA6606DBSD0320	32.0
06D * 541 ** A06 **	06DA6606DBSB0400	06DA6606DBSC0400	06DA6606DBSD0400	40.0
06D * 541 ** A08 **	06DA6606DBSB0750	06DA6606DBSC0750	06DA6606DBSD0750	75.0
06D * 541 ** A09 **	06DA6606DBSB0400	06DA6606DBSC0400	06DA6606DBSD0400	40.0
06D * 541 ** A12 **	06DA6606DBSB0890	06DA6606DBSC0890	06DA6606DBSD0890	89.0
06D * 541 ** A13 **	06DA6606DBSB0542	06DA6606DBSC0542	06DA6606DBSD0542	54.2
06D * 541 ** A31 **	06DA6606DBSB0320	06DA6606DBSC0320	06DA6606DBSD0320	32.0
06D * 541 ** A32 **	06DA6606DBSB0890	06DA6606DBSC0890	06DA6606DBSD0890	89.0
06D * 541 ** A36 **	06DA6606DBSB0400	06DA6606DBSC0400	06DA6606DBSD0400	40.0
06D * 718 ** A13 **	06DA6606DBSB0164	06DA6606DBSC0164	06DA6606DBSD0164	16.4
06D * 718 ** A31 **	06DA6606DBSB0108	06DA6606DBSC0108	06DA6606DBSD0108	10.8
06D * 718 ** A32 **	06DA6606DBSB0270	06DA6606DBSC0270	06DA6606DBSD0270	27.0
06D * 718 ** A36 **	06DA6606DBSB0135	06DA6606DBSC0135	06DA6606DBSD0135	13.5
06D * 724 ** A01 **	06DA6606DBSB0197	06DA6606DBSC0197	06DA6606DBSD0197	19.7
06D * 724 ** A06 **	06DA6606DBSB0220	06DA6606DBSC0220	06DA6606DBSD0220	22.0
06D * 724 ** A12 **	06DA6606DBSB0488	06DA6606DBSC0488	06DA6606DBSD0488	48.8
06D * 724 ** A13 **	06DA6606DBSB0266	06DA6606DBSC0266	06DA6606DBSD0266	26.6
06D * 724 ** A31 **	06DA6606DBSB0176	06DA6606DBSC0176	06DA6606DBSD0176	17.6
06D * 724 ** A32 **	06DA6606DBSB0440	06DA6606DBSC0440	06DA6606DBSD0440	44.0
06D * 724 ** A36 **	06DA6606DBSB0220	06DA6606DBSC0220	06DA6606DBSD0220	22.0
06D * 725 ** A06 **	06DA6606DBSB0220	06DA6606DBSC0220	06DA6606DBSD0220	22.0
06D * 725 ** A12 **	06DA6606DBSB0488	06DA6606DBSC0488	06DA6606DBSD0488	48.8
06D * 725 ** A13 **	06DA6606DBSB0266	06DA6606DBSC0266	06DA6606DBSD0266	26.6
06D * 725 ** A31 **	06DA6606DBSB0176	06DA6606DBSC0176	06DA6606DBSD0176	17.6
06D * 725 ** A32 **	06DA6606DBSB0440	06DA6606DBSC0440	06DA6606DBSD0440	44.0
06D * 725 ** A36 **	06DA6606DBSB0220	06DA6606DBSC0220	06DA6606DBSD0220	22.0
06D * 808 ** A13 **	06DA6606DBSB0105	06DA6606DBSC0105	06DA6606DBSD0105	10.5
06D * 808 ** A31 **	06DA6606DBSB0070	06DA6606DBSC0070	06DA6606DBSD0070	7.0
06D * 808 ** A32 **	06DA6606DBSB0174	06DA6606DBSC0174	06DA6606DBSD0174	17.4
06D * 808 ** A34 **	06DA6606DBSB0178	06DA6606DBSC0178	06DA6606DBSD0178	17.8
06D * 808 ** A36 **	06DA6606DBSB0087	06DA6606DBSC0087	06DA6606DBSD0087	8.7

COMPRESSOR MODEL NUMBER	ELECTRONIC OVERCURRENT PROTECTION SERVICE RETROFIT (THREE PHASE) KIT NUMBER			MCC
	Control Voltage			
	110-220V	24V AC	24V DC	(Amps)
06D * 816 ** A13 **	06DA6606DBSB0266	06DA6606DBSC0266	06DA6606DBSD0266	26.6
06D * 816 ** A31 **	06DA6606DBSB0176	06DA6606DBSC0176	06DA6606DBSD0176	17.6
06D * 816 ** A32 **	06DA6606DBSB0440	06DA6606DBSC0440	06DA6606DBSD0440	44.0
06D * 816 ** A34 **	06DA6606DBSB0400	06DA6606DBSC0400	06DA6606DBSD0400	40.0
06D * 816 ** A36 **	06DA6606DBSB0220	06DA6606DBSC0220	06DA6606DBSD0220	22.0
06D * 818 ** A01 **	06DA6606DBSB0197	06DA6606DBSC0197	06DA6606DBSD0197	19.7
06D * 818 ** A04 **	06DA6606DBSB0546	06DA6606DBSC0546	06DA6606DBSD0546	54.6
06D * 818 ** A06 **	06DA6606DBSB0246	06DA6606DBSC0246	06DA6606DBSD0246	24.6
06D * 818 ** A12 **	06DA6606DBSB0488	06DA6606DBSC0488	06DA6606DBSD0488	48.8
06D * 818 ** A13 **	06DA6606DBSB0266	06DA6606DBSC0266	06DA6606DBSD0266	26.6
06D * 818 ** A31 **	06DA6606DBSB0176	06DA6606DBSC0176	06DA6606DBSD0176	17.6
06D * 818 ** A32 **	06DA6606DBSB0440	06DA6606DBSC0440	06DA6606DBSD0440	44.0
06D * 818 ** A34 **	06DA6606DBSB0400	06DA6606DBSC0400	06DA6606DBSD0400	40.0
06D * 818 ** A36 **	06DA6606DBSB0220	06DA6606DBSC0220	06DA6606DBSD0220	22.0
06D * 820 ** A13 **	06DA6606DBSB0266	06DA6606DBSC0266	06DA6606DBSD0266	26.6
06D * 820 ** A31 **	06DA6606DBSB0176	06DA6606DBSC0176	06DA6606DBSD0176	17.6
06D * 820 ** A32 **	06DA6606DBSB0440	06DA6606DBSC0440	06DA6606DBSD0440	44.0
06D * 820 ** A36 **	06DA6606DBSB0220	06DA6606DBSC0220	06DA6606DBSD0220	22.0
06D * 824 ** A01 **	06DA6606DBSB0249	06DA6606DBSC0249	06DA6606DBSD0249	24.9
06D * 824 ** A06 **	06DA6606DBSB0278	06DA6606DBSC0278	06DA6606DBSD0278	27.8
06D * 824 ** A12 **	06DA6606DBSB0690	06DA6606DBSC0690	06DA6606DBSD0690	69.0
06D * 824 ** A13 **	06DA6606DBSB0336	06DA6606DBSC0336	06DA6606DBSD0336	33.6
06D * 824 ** A31 **	06DA6606DBSB0222	06DA6606DBSC0222	06DA6606DBSD0222	22.2
06D * 824 ** A32 **	06DA6606DBSB0555	06DA6606DBSC0555	06DA6606DBSD0555	55.5
06D * 824 ** A34 **	06DA6606DBSB0505	06DA6606DBSC0505	06DA6606DBSD0505	50.5
06D * 824 ** A36 **	06DA6606DBSB0278	06DA6606DBSC0278	06DA6606DBSD0278	27.8
06D * 825 ** A01 **	06DA6606DBSB0222	06DA6606DBSC0222	06DA6606DBSD0222	22.2
06D * 825 ** A06 **	06DA6606DBSB0278	06DA6606DBSC0278	06DA6606DBSD0278	27.8
06D * 825 ** A12 **	06DA6606DBSB0690	06DA6606DBSC0690	06DA6606DBSD0690	69.0
06D * 825 ** A13 **	06DA6606DBSB0336	06DA6606DBSC0336	06DA6606DBSD0336	33.6
06D * 825 ** A31 **	06DA6606DBSB0222	06DA6606DBSC0222	06DA6606DBSD0222	22.2
06D * 825 ** A32 **	06DA6606DBSB0555	06DA6606DBSC0555	06DA6606DBSD0555	55.5
06D * 825 ** A34 **	06DA6606DBSB0505	06DA6606DBSC0505	06DA6606DBSD0505	50.5
06D * 825 ** A36 **	06DA6606DBSB0278	06DA6606DBSC0278	06DA6606DBSD0278	27.8

SERVICE RETROFIT KITS (SINGLE PHASE):

The below kits are intended to service Carlyle 06D and 06CC (16-37 Cfm) compressors manufactured BEFORE August 2015, S/N starting with '3115', with the factory installed electromechanical overcurrent protection and a single phase motor. The provided service kits are for RETROFIT of an existing compressor with the electromechanical overcurrent protection to the electronic overcurrent protection scheme. When selecting the appropriate kit, please be sure to select the required control voltage, as the retrofit module will require OEM customers to provide control voltage to the terminal box of the compressor. All kits include a replacement large folded terminal box, electronic overcurrent protection module and current transformer, with a pre-programmed MCC value based on the compressor model number. For additional information on the kit and installation, please see 99TA516185A located on the Carlyle Compressor website (www.carlylecompressor.com).

COMPRESSOR MODEL NUMBER	ELECTRONIC OVERCURRENT PROTECTION SERVICE RETROFIT (SINGLE PHASE) KIT NUMBER			MCC
	Control Voltage			
	110-220V	24V AC	24V DC	(Amps)
06D * 013 ** A33 **	06DA6706DBSB0326	06DA6706DBSC0326	06DA6706DBSD0326	32.6
06D * 109 ** A03 **	06DA6706DBSB0240	06DA6706DBSC0240	06DA6706DBSD0240	24.0
06D * 109 ** A33 **	06DA6706DBSB0240	06DA6706DBSC0240	06DA6706DBSD0240	24.0
06D * 313 ** A03 **	06DA6706DBSB0568	06DA6706DBSC0568	06DA6706DBSD0568	56.8
06D * 313 ** A33 **	06DA6706DBSB0400	06DA6706DBSC0400	06DA6706DBSD0400	40.0
06D * 316 ** A03 **	06DA6706DBSB0568	06DA6706DBSC0568	06DA6706DBSD0568	56.8
06D * 316 ** A33 **	06DA6706DBSB0400	06DA6706DBSC0400	06DA6706DBSD0400	40.0
06D * 518 ** A03 **	06DA6706DBSB0568	06DA6706DBSC0568	06DA6706DBSD0568	56.8
06D * 718 ** A33 **	06DA6706DBSB0400	06DA6706DBSC0400	06DA6706DBSD0400	40.0
06D * 808 ** A03 **	06DA6706DBSB0280	06DA6706DBSC0280	06DA6706DBSD0280	28.0
06D * 808 ** A33 **	06DA6706DBSB0280	06DA6706DBSC0280	06DA6706DBSD0280	28.0

4.11 — Electrical Hook-Up

Consult wiring diagram located inside compressor terminal box cover and reference diagrams shown below for wiring hook-up connection locations. See 3.29, page 97 for Terminal Box Packages.

06D & 06CC (17-37 Cfm) COMPRESSORS

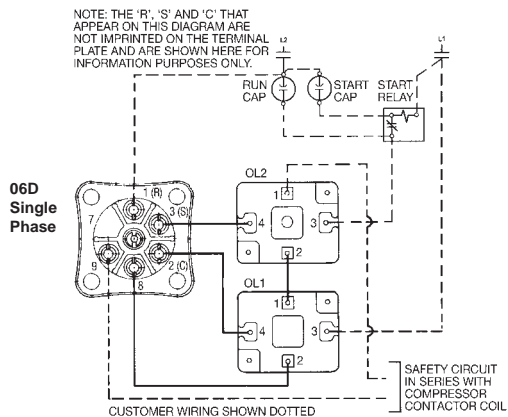

Single Phase Electromechanical Overcurrent Protection

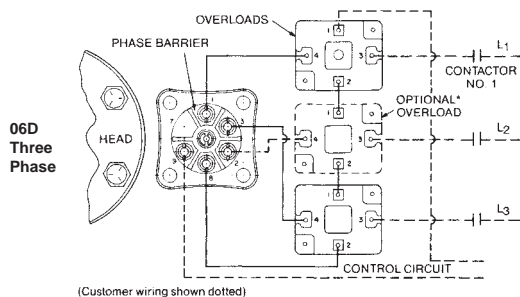

* 3rd overload required on some compressors. See 4.9 06D compressor overloads.

Fig. 26 — Three Phase Electromechanical Overcurrent Protection

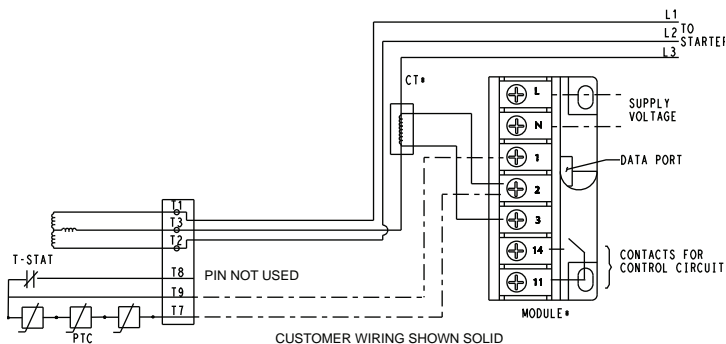

Fig. 27 — Electronic Overcurrent Protection (SERVICE ONLY)

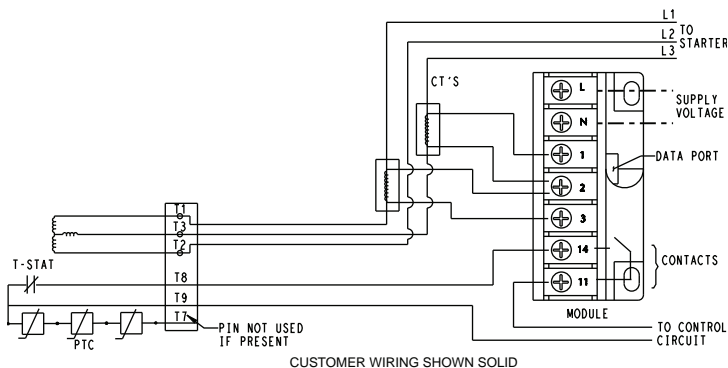

Fig. 28 — Three Phase Electronic Overcurrent Protection (RETROFIT ONLY)

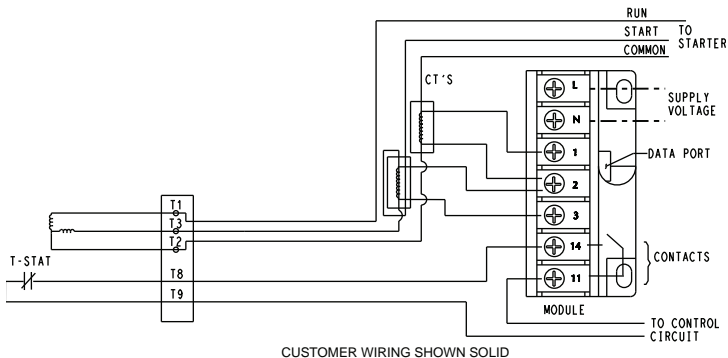

Fig. 29 — Single Phase Electronic Overcurrent Protection (RETROFIT ONLY)

06E COMPRESSORS (ACROSS-THE-LINE [XL] START)

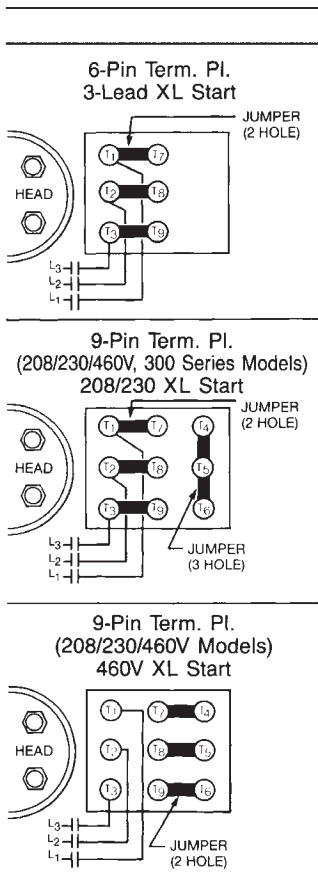
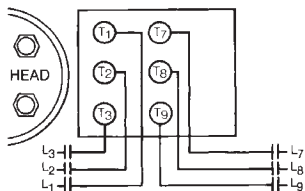

Fig. 30 — 06E Compressors (Across-the-Line [XL] Start)

06E COMPRESSORS (PART WINDING START)

6-Pin Term. Pl.
6-Lead PW Start



9-Pin Term. Pl.
(208/230/460V, 300 Series Models)
208/230 PW Start Only

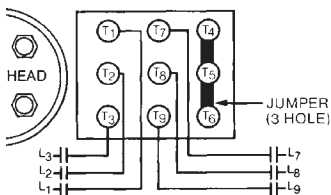

9-Pin Term. Pl.
(460V, 600 Series Models)
460 PW Start

WARNING

With 208/230/460V
300 Series Models, the 460V
cannot be wired for PW
start. Use distinct 460V
600 Series Models for any
460V PW application.

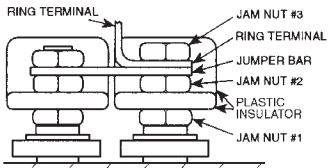

**Terminal Post Arrange-
ment, Detail View (06E
and 06CC 50 to 99 Cfm)**

**Fig. 31 — 06E Compressors
(Part Winding Start)**

4.12 — Voltage and Current Unbalance

VOLTAGE UNBALANCE (Maximum 2%)

Voltage unbalance can cause motors to overheat and fail. Below is the recommended method for determining voltage unbalance.

Example: Supply voltage is 240-3-60

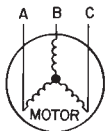

$$AB = 243 \text{ volts}$$

$$BC = 236 \text{ volts}$$

$$AC = 238 \text{ volts}$$

$$\begin{aligned} \text{Average Voltage} &= \frac{243 + 236 + 238}{3} \\ &= \frac{717}{3} \\ &= 239 \text{ volts} \end{aligned}$$

Determine maximum deviation from average voltage:

$$(AB) 243 - 239 = 4 \text{ volts}$$

$$(BC) 239 - 236 = 3 \text{ volts}$$

$$(AC) 239 - 238 = 1 \text{ volt}$$

Maximum deviation is 4 volts.

Determine % voltage unbalance:

$$\begin{aligned} \% \text{ Voltage unbalance} &= 100 \times \frac{4}{239} \\ &= 1.7\% \end{aligned}$$

This amount of phase unbalance is satisfactory as it is below the maximum allowable of 2%.

IMPORTANT: If the supply voltage phase unbalance is more than 2%, contact your local electric utility company immediately.

CURRENT UNBALANCE (Maximum 10%)

Voltage unbalance will cause a current unbalance, but a current unbalance does not necessarily mean that a voltage unbalance exists. A loose terminal connection or a build-up of dirt or carbon on one set of contacts (using the example of L1 as the problem leg) would cause a higher resistance on that leg (L1) than on L2 and L3. The current follows the path of least resistance, so the current increases in legs L2 and L3. Higher current causes more heat to be generated in the motor windings.

Percent (%) of current unbalance is calculated in the same way as voltage unbalance (see the previous section), with a maximum acceptable current unbalance of 10%.

5.0 COMPRESSOR SERVICE WORKSHEETS

Carlyle recommends that the Compressor Service Worksheets (pages 137 and 138) be copied (and enlarged, if preferred) and filled out for each compressor at initial start-up and each time the compressor is serviced. Comparing the data from current worksheets to past records will allow the service technician to diagnose system changes and prevent compressor failures. This information is also very useful in preventing a repeat failure.

06D, 06E Compressor Service Worksheet

Mechanic: _____ Date: _____

From Compressor Nameplate:

Model No.: _____

Serial No.: _____

Motor No.: _____

Voltage: _____

Allow compressor to run for 30 minutes, then obtain the pressures and body temperature at the locations shown below. Check for proper oil return in sight glass.

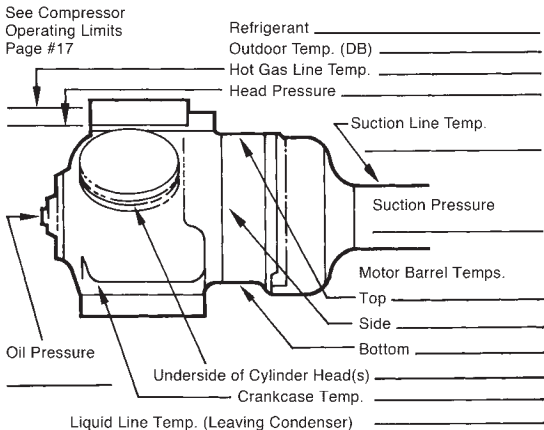

COMPRESSOR VOLTAGE/AMP VALUES

PH	VOLTAGE	CURRENT
1 ϕ	C-R: _____	C: _____
	C-S: _____	R: _____
	R-S: _____	S: _____
3 ϕ	L ₁ -L ₂ : _____	L ₁ : _____
	L ₁ -L ₃ : _____	L ₂ : _____
	L ₂ -L ₃ : _____	L ₃ : _____
		PART WINDING
	L ₇ -L ₈ : _____	L ₇ : _____
	L ₇ -L ₉ : _____	L ₈ : _____
	L ₈ -L ₉ : _____	L ₉ : _____

Make copies of this worksheet to record data at initial start-up and whenever the compressor is serviced.

LEGEND: C - Common R - Run S - Start

06CC Compressor Service Worksheet

Mechanic: _____ Date: _____

From Compressor Nameplate:

Model No.: _____

Serial No.: _____

Motor No.: _____

Voltage: _____

Allow compressor to run for 30 minutes, then obtain the pressures and body temperature at the locations shown below. Check for proper oil return in sight glass.

See Compressor Operating Limits, page 17.

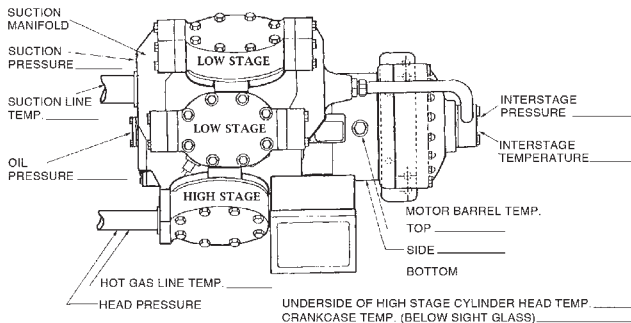

COMPRESSOR VOLTAGE/AMP VALUES

PH	VOLTAGE	CURRENT
1φ	C-R: _____	C: _____
	C-S: _____	R: _____
	R-S: _____	S: _____
3φ	L ₁ -L ₂ : _____	L ₁ : _____
	L ₁ -L ₃ : _____	L ₂ : _____
	L ₂ -L ₃ : _____	L ₃ : _____
		PART WINDING
	L ₇ -L ₈ : _____	L ₇ : _____
	L ₇ -L ₉ : _____	L ₈ : _____
	L ₉ : _____	

Make copies of this worksheet to record data at initial start-up and whenever the compressor is serviced.

LEGEND: C - Common R - Run S - Start

6.0 — SMART UNLOADING & PWM VALVE

The SMART controller is designed to operate the compressor cylinder head unloaders or a PWM Valve installed in the compressor's suction line using Pulse Width Modulation (PWM).

See Application Guide 574-078 at www.carlylecompressor.com.

6.1 — Functional Overview

The SMART unloading controller allows continuous modulation of the compressor capacity using the steps of mechanical unloading or the PWM Valve. Here is how it works: An analog output signal from the system rack controller provides a 0-10 VDC signal to the SMART controller. Based on the signal, the SMART controller continuously modulates the compressor unloader coils to deliver an equivalent linear change in the compressor capacity output to precisely meet thermal load demand. In addition, the SMART controller will control discharge temperature by operating the accessory cylinder head fan and liquid injection valve as required, maintaining safe and reliable operation. If discharge temperature exceeds allowable limits, the SMART controller will automatically turn the compressor off to protect against compressor failure.



Fig. 32 — SMART Controller

6.2 — Identification

A compressor with smart unloading heads can be identified by a “Y” in the customer model number note on the compressor nameplate. Additionally, a smart unloading cylinder head can be identified by a “**horizontal line**” stamped on the cylinder head.

Model Family	Model Number Change	Example
06D semi-hermetic	Insert “Y” for 13th digit	06DR3370DA36YA
06E semi-hermetic	Insert “Y” for 5th digit	06ERY7530A

Compressors applying a **PWM Valve** installed in the suction line of the compressor will not have a “Y” in the customer model number or any marking on the cylinder heads. The compressor should be a factory standard compressor with no unloading heads.

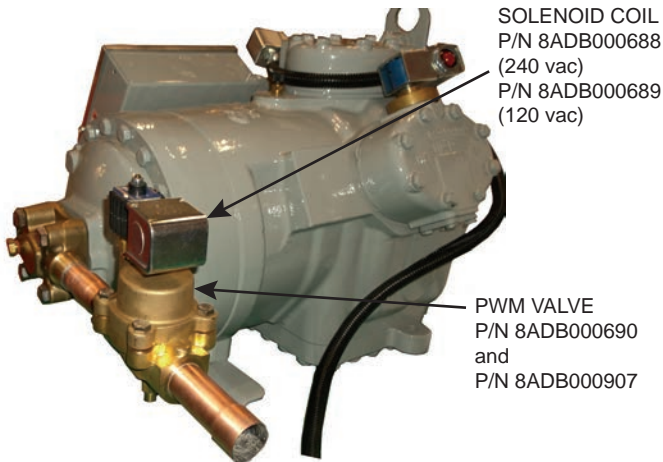

Fig. 33 — PWM Valve Installed

6.3 — Smart Controller Inputs/Outputs

CONTROLLER INPUT SIGNAL

The smart controller (see Fig. 34) receives a 0 to 10 VDC input signal from the system's rack controller. This signal is inversely proportional to the capacity demand required from the compressor. A 0 VDC demand signal represents a 100% capacity output from the compressor. The minimum demand voltage signal (compressor fully unloaded), depends on the compressor configuration selected by the smart controller DIP switches (see Section 6.4).

POWER SUPPLY INPUT

The smart controller requires a 24 VAC ($\pm 10\%$), 50/60 Hz source to power the module. The maximum continuous rating is 5 VA. Control power should be isolated with a transformer from the main power supply.

NC/NC TERMINALS

The two NC terminals are currently not used and provide no functionality at this time. Do not use.

DISCHARGE TEMPERATURE SENSOR INPUT

The smart controller has the capability to monitor and control the compressor's refrigerant discharge temperature. The thermistor input range is -22°F to 320°F , accuracy of $-3\%/+0\%$, with a maximum allowable sensor cable length of 30 ft. The smart controller will process the input from the discharge temperature sensor and operate the compressor's cylinder head fan and liquid injection valve as required to control compressor discharge temperature below 230°F .

Every smart controller comes with a 1000 ohm resistor installed. Remove only if installing the Carlyle discharge temperature sensor for discharge temperature control; otherwise do not remove the resistor.

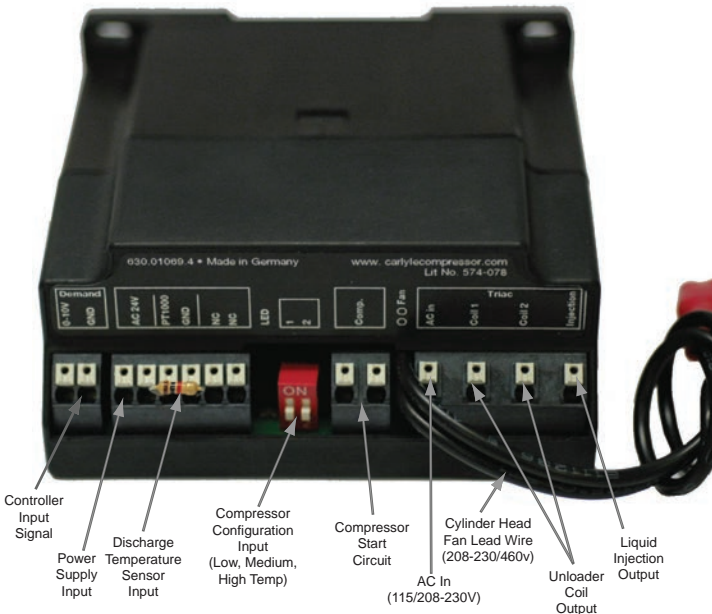

Fig. 34 — Smart Controller

COMPRESSOR CONFIGURATION INPUT

The smart controller is configurable for all 06D, 06E, and 06M compressor models by simply adjusting the onboard DIP switches. The DIP switches configure the compressor for Low or Medium/High temperature application and set the compressor's capacity modulation range profile. See Section 6.4 for configuration details. Controller power must be cycled off/on if the configuration switches are changed during system operation for that change to take effect.

COMP/ALARM

The compressor contactor output is a relay output. The relay operating voltage is 24 to 240 VAC with a maximum continuous current of 2.5 amps (600 VA). The compressor COMP contactor will open when any of the following conditions exist:

- Loss of 24 VAC supply power
- Discharge temperature sensor failure, discharge temperature $>295^{\circ}\text{F}$
- The input demand voltage is > 8.0 VDC.

The Comp/Alarm contactor should be wired into the compressor's control power circuit if the Carlyle discharge temperature sensor is being used to control compressor discharge temperature. This will ensure the compressor will shut down if discharge temperature exceeds 295°F or sensor fails. The triac output for Coil 1, Coil 2, and the LIV (Liquid Injection Valve) will open, disabling the unloader valves and liquid injection valve if the Comp/Alarm contactor is opened.

CYLINDER HEAD FAN LEAD WIRES

The smart controller has two 6-in. lead wires for wiring to the compressor's cylinder head fan. The smart controller will energize/de-energize the internal cylinder head fan relay as required to maintain discharge temperatures below 220°F . The lead wires are rated for 230/460 VAC with a maximum continuous rating of 2.5 amps.

AC IN

Line voltage input to provide power to the unloader solenoid coils and the liquid injection solenoid coil. Rated for 115/208-230 VAC with a maximum continuous rating of 30 VA.

COIL #1, COIL #2

The unloader solenoid output is a triac output. The triac is rated for 115/208-230 VAC with a maximum continuous rating of 30 VA. The smart controller energizes the unloader solenoid coil in an on/off sequence per the 0 to 10 VDC analog input signal received by the smart controller.

LIQUID INJECTION

The liquid injection solenoid output is a triac output. The triac is rated for 115/208-230 VAC with a maximum continuous rating of 30 VA. The smart controller will energize the liquid injection solenoid as required to provide compressor motor cooling and maintain compressor discharge below 230°F.

6.4 — Smart Controller Configuration

The smart controller's configuration switch is a manual switch the operator must configure before powering up the unit. The configuration DIP switch has 4 positions (A, B, C, D) and corresponds to the type of compressor and compressor modulation range. The table below and Fig. 35 and 36 show the DIP switch positions to correctly configure the smart controller to the smart compressor. The configuration switch can be positioned at any time while the smart controller is off.

Config. DIP Switch Position	Compressor Models	# of Compressor Cylinders	# of Unloaders on Compressor	Modulation Range	Electrical Schematic
A	06D, 06E	6	2	33% - 100%	Figure 37
B	06D, 06E	6	2	67% - 100%	Figure 37
	06M	3	1	67% - 100%	Figure 38
C	06D, 06E	4	1	50% - 100%	Figure 38
	06D, 06CC, 06M	3, 4, or 6	PWM Valve	20% - 100%	Figure 38
D	All	3, 4, or 6	None	None	NA

Smart Controller LED Indicator Status Lights and Output Status

Condition	Description	LED Status	COMP Contactor	Coil 1 & 2 Output	LIQUID INJECTION VALVE Injection Output	Cylinder Head Fan Control
Compressor ON. Demand Signal < 8 vdc	Compressor is operating under normal modulation control.	GREEN Constant Blinking	Closed	PWM as Required	As Required	As Required
Demand signal > 8 vdc	There are no active alarm states and the controller assumes compressor is off due to no demand for cooling.	GREEN Solid	Open	Disabled. No PWM Control.	Disabled	Disabled
High Discharge Temperature > 295°F	Compressor is shut down due to high discharge gas temperature. Will auto reset, compressor ON, in 5 minutes if discharge temperature < 230°F and demand signal < 8 VDC.	RED 2 blinks & pause	Open	Disabled. No PWM Control.	Disabled	Functional/ Operational
Discharge Gas Temperature Sensor Failure	Compressor is shut down under an alarm for discharge gas temperature sensor failure. Manual reset required.	RED Long blink, two short blinks & pause	Open	Disabled. No PWM Control.	Disabled	Disabled
Compressor OFF. Module Failure	Invalid value at the demand input or module internal failure.	RED Constant Blink	Open	Disabled. No PWM Control.	Disabled	Disabled

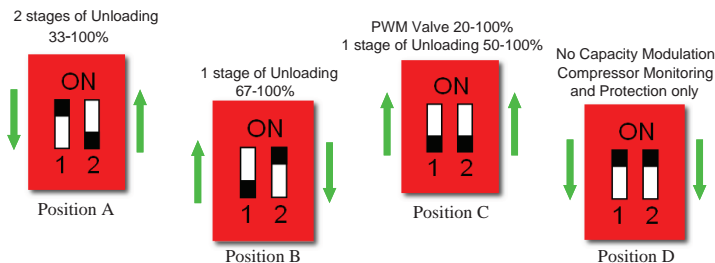

Fig. 35 — Smart Controller Configuration (DIP Switches)

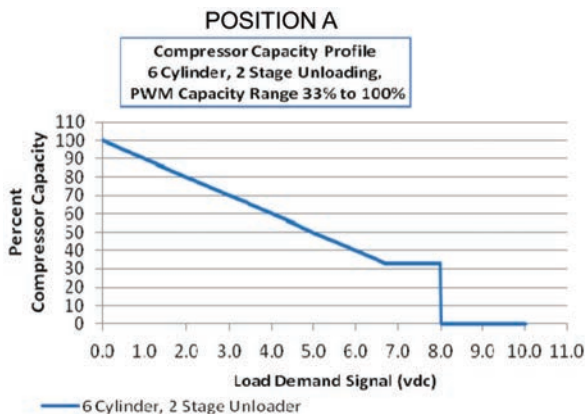

Fig. 36 — Smart Controller Configuration (DIP Switches), Compressor Capacity

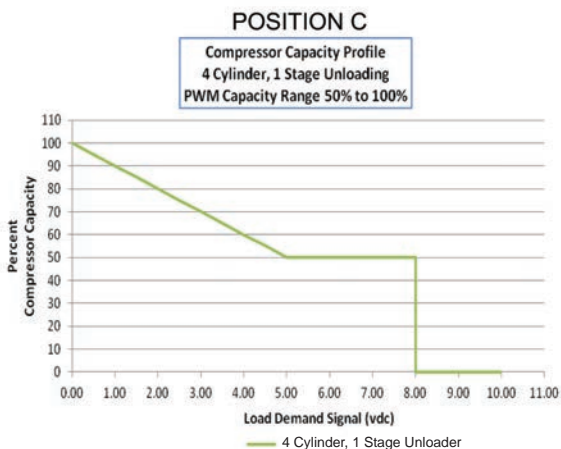
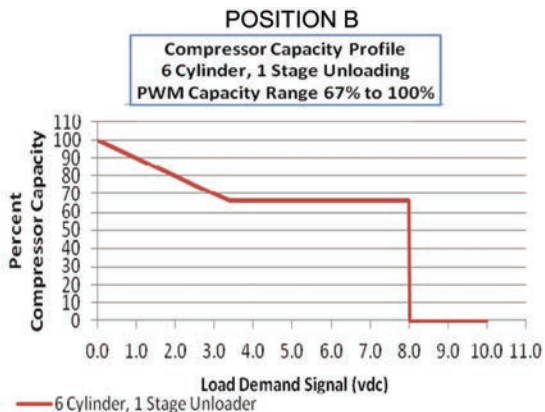

Fig. 36 —Smart Controller Configuration (DIP Switches), Compressor Capacity (cont)

Carlyle Smart Unloading Module Wiring Schematic

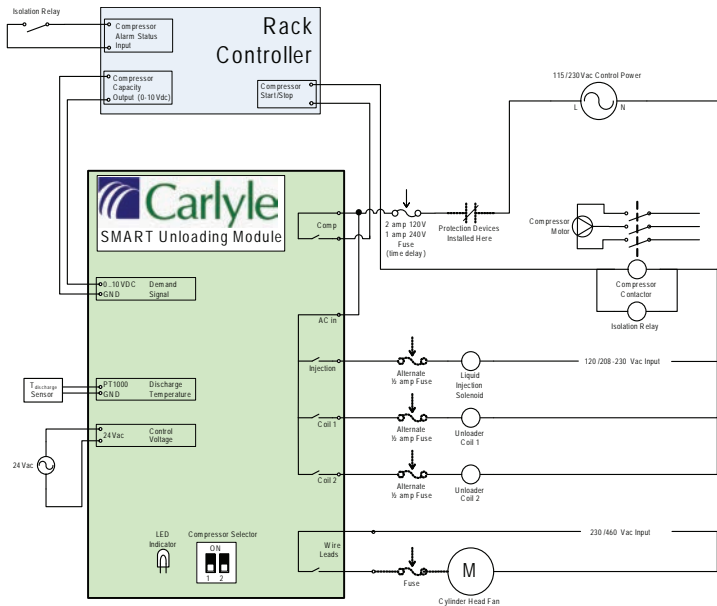

Fig. 37 — Electrical Schematic, Compressors with 2 Unloading Heads

NOTES FOR FIG 36 AND 37:

1. The smart controller must be configured based on the type of compressor it is controlling. See Section 6.4 for configuration details.
2. The compressor is loaded when the unloader solenoid coil is de-energized and unloaded when the solenoid coil is energized.
3. The power for the compressor contactor, unloader coils, and liquid injection solenoid may be either 115 VAC or 230 VAC. All components must be of the same voltage. Fusing for this should be a 2 amp-120V or 1 amp-240V time delay fuse. Alternately, the components may be fused individually with ½ amp fuses.
4. The compressor COMP contactor will open when any of the following conditions exist: loss of 24 VAC supply power, discharge temperature sensor failure, discharge temperature >295°F, or the input demand voltage is > 8.0 VDC. The COMP contactor should be wired into the compressor's control power circuit if the Carlyle discharge temperature sensor is being used to control compressor discharge temperature. This will ensure the compressor will shut down if discharge temperature exceeds 295°F or the sensor fails. The triac output for Coil 1, Coil 2, and the LIV will open, disabling the unloader valves and liquid injection valve if the COMP contactor is opened.
5. The smart controller cylinder head fan lead wires may be either single phase 230 VAC or 460 VAC. The cylinder head fan relay will open at a loss of 24 VAC supply power, discharge temperature sensor failure, or input demand voltage > 8.0 VDC. Upon a compressor discharge temperature trip (> 295°F) the cylinder head fan relay will **stay closed**. Typically the compressor's cylinder head fan will shut down when the compressor is off, but with the smart controller the fan will still operate to reduce discharge temperature below 230°F so the compressor will auto restart following a 5-minute time delay.

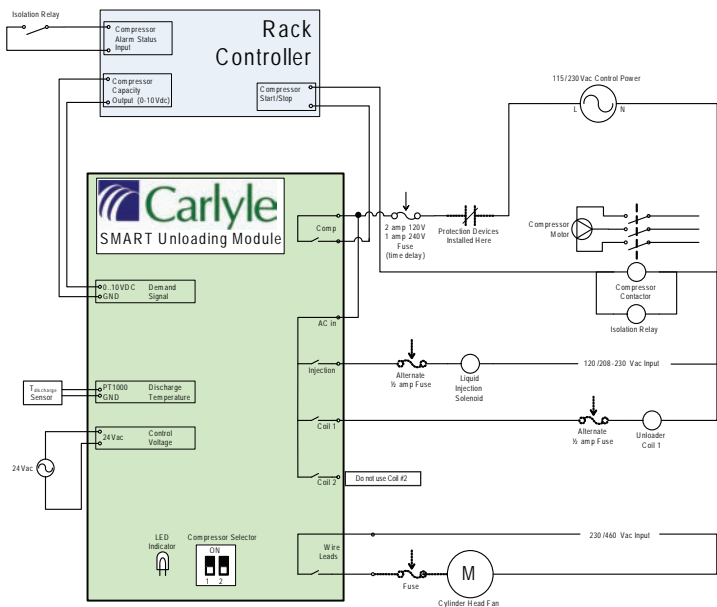

Fig. 38 — Electrical Schematic, Compressors with 1 Unloading Head or PWM Valve

6.5 — Service Table

NOTE: Not all smart unloading applications use the smart controller for discharge temperature control and protection. The Service and LED tables allow the Installer and/or Service Technician the ability to verify the smart controller is functioning properly once installation is complete and the refrigeration system is ready for service. Based on the voltage input signal to the smart controller, the PWM cycle and LED status of the smart compressor can be checked per the tables.

Service Table



06D/E COMPRESSOR CAPACITY				POSITION A		POSITION B	POSITION C
				6 CYLINDER COMPRESSOR		3 AND 6 CYLINDER COMPRESSOR	4 CYLINDER COMPRESSOR
DEMAND SIGNAL	PERCENTAGE			CAPACITY MODULATION		CAPACITY MODULATION	CAPACITY MODULATION
				33 - 100%		67 - 100%	50 - 100%
vdc	A	B	C	Seconds Energized		Seconds Energized	Seconds Energized
				Coil #1	Coil #2	Lead Coil	Coil #1
0.00	100	100	100	0.0	0.0	0.0	0.0
0.50	95	95	95	4.5	0.0	4.5	3.0
1.00	90	90	90	9.0	0.0	9.0	6.0
1.50	85	85	85	13.5	0.0	13.5	9.0
2.00	80	80	80	18.0	0.0	18.0	12.0
2.50	75	75	75	22.5	0.0	22.5	15.0
3.00	70	70	70	27.0	0.0	27.0	18.0
3.30	67	67	67	30.0	0.0	30.0	19.7
3.40	66	67	66	0.0	30.0	30.0	21.4
3.50	65	67	65	1.5	30.0	30.0	21.0
4.00	60	67	60	6.0	30.0	30.0	24.0
4.50	55	67	55	10.5	30.0	30.0	27.0
5.00	50	67	50	15.0	30.0	30.0	30.0
5.50	45	67	50	19.5	30.0	30.0	30.0
6.00	40	67	50	24.0	30.0	30.0	30.0
6.50	35	67	50	28.5	30.0	30.0	30.0
6.70	33	67	50	30.0	30.0	30.0	30.0
7.00	33	67	50	30.0	30.0	30.0	30.0
7.50	33	67	50	30.0	30.0	30.0	30.0
8.00	33	67	50	30.0	30.0	30.0	30.0

6.6 — Compressor Protection and Control

The smart controller provides improved temperature control and protection. The module is equipped with a discharge temperature sensor input allowing on-demand engagement of the liquid injection valve and cylinder head fan as follows.

TEMPERATURE CONTROL

Increasing Discharge Temperature:

220°F — Cylinder Head Fan ON

230°F — Injection Valve OPEN

295°F — Compressor SHUTDOWN alarm

Decreasing Discharge Temperature:

(See Fig. 39)

230°F — Compressor alarm/comp RESET

210°F — Injection Valve CLOSED

175°F — Cylinder Head Fan OFF

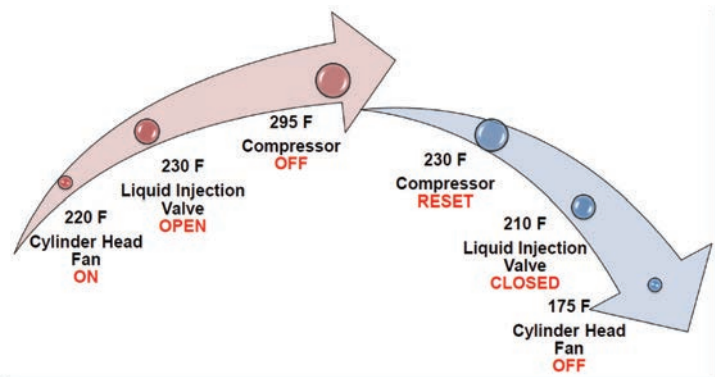

Fig. 39 — Discharge Temperatures

6.7 — PWM Valve

The Carlyle pulse width modulation (PWM) valve is a robust high cycle capacity control valve designed to modulate and control compressor capacity from 20% to 100% of compressor full load. In conjunction with the Carlyle smart

controller, the PWM valve can easily be controlled to provide a linear incremental step change to compressor capacity. The PWM valve is controlled in the same manner as the unloader head on a compressor, by using a 30-second PWM control signal from the smart controller (see Functional Overview on page 139).

The Carlyle PWM valve (Fig. 40) is designed to work specifically with the Carlyle 06D, 06CC, and 06M compressor models for all low, medium, and high temperature applications.

NOTE: When applying the smart controller with the PWM valve the standard non-unloading compressor models should be used and therefore the compressor will **not** have a “Y” in the compressor model number. See the PWM Valve Dimensions section for correct usage.



Fig. 40 — PWM Valve PN 8ADB000690 and 8ADB000907

VALVE INSTALLATION AND OPERATION

- Inspect the PWM valve for any shipping damage and verify the correct part number is called out on the valve.
- The PWM valve installs in the suction line of the compressor. The valve should be installed along a straight tubing run leading to the inlet of the compressor's suction service valve.

- The PWM valve must be mounted in a horizontal position so the solenoid coil valve stem is in the vertical position. Mounting in any other direction or imposing a tilt angle may result in valve malfunction. See Fig. 41.
- The PWM valve has 1-1/8 ODF connections for brazed installation. Do not braze the valve in-place with the solenoid coil installed, and always wrap the valve in wet rags to prevent any heat damage to the valve during the brazing process.
- The PWM valve has a refrigerant flow directional arrow located on the top of the valve to ensure correct horizontal orientation. See Fig. 42.

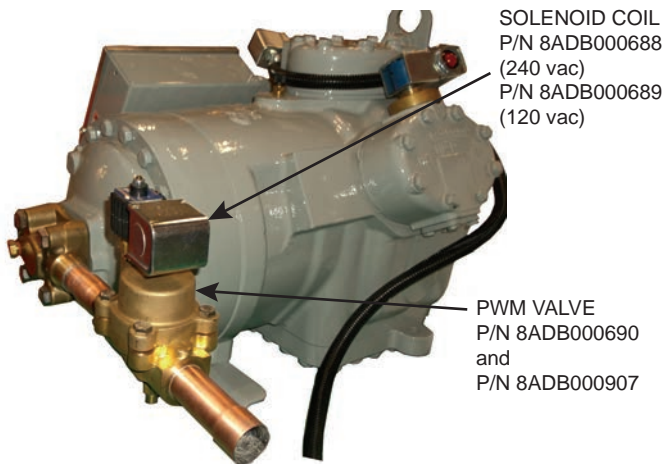

Fig. 41 — Solenoid Coil Valve and PWM Stem Position

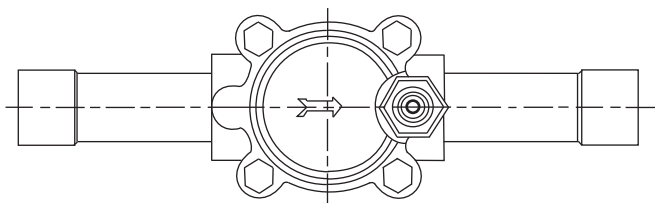

Fig. 42 — Refrigerant Flow Direction

- The PWM valve is a normally closed valve and requires a solenoid coil to be energized to open the valve. The PWM valve is equipped with a manual lifting stem, when front seated, will force the valve fully open.
- Once the PWM valve is brazed in-place, the solenoid coil can be installed. Use Carlyle solenoid coil 8ADB000688 or 8ADB000689. These coils have been qualified and life-cycle tested with the PWM valve. The use of any other coil is not approved by Carlyle.
- The PWM valve solenoid coil should wire back to the Smart Control, Coil #1 position as shown in electrical schematic Fig. 38.
- The PWM valve should not be cycled by the smart controller when the compressor is not operating. Power to the PWM valve solenoid coil should be interrupted whenever the compressor trips off or is intentionally taken out of service.
- The PWM valve is designed to open/close at a specified rate to modulate compressor capacity. Upon valve closure, the compressor crankcase will pull into a vacuum. The 06D, 06CC, and 06M compressors have all been functionally tested and approved to operate in this manner.

NOTE: If the PWM valve fails in the close position, the compressor suction line will isolate and the compressor will pulldown into a continuous vacuum. It is recommended that a pressure transducer be installed to the body of the compressor for monitoring crankcase pressure by the system controller and should be set up to trip the compressor off if in a vacuum for more then 120 seconds.

PWM VALVE CONFIGURATION

The PWM valve modulation cycle is controlled by the smart controller. The smart controller configuration DIP switches must both be placed in the upward position to send the correct PWM signal to the PWM valve. This should be done prior to powering up the smart controller.

The system controller measures temperature or pressure to calculate the needed compressor capacity and communicates that capacity to the smart controller via a 1-5 VDC analog signal as shown by the system curve. See Fig. 43.

NOTE: A control signal less then 1 VDC will result in a compressor capacities $< 20\%$. Do not allow the control voltage signal to drop to zero volts. Zero volts represents 0% compressor capacity.

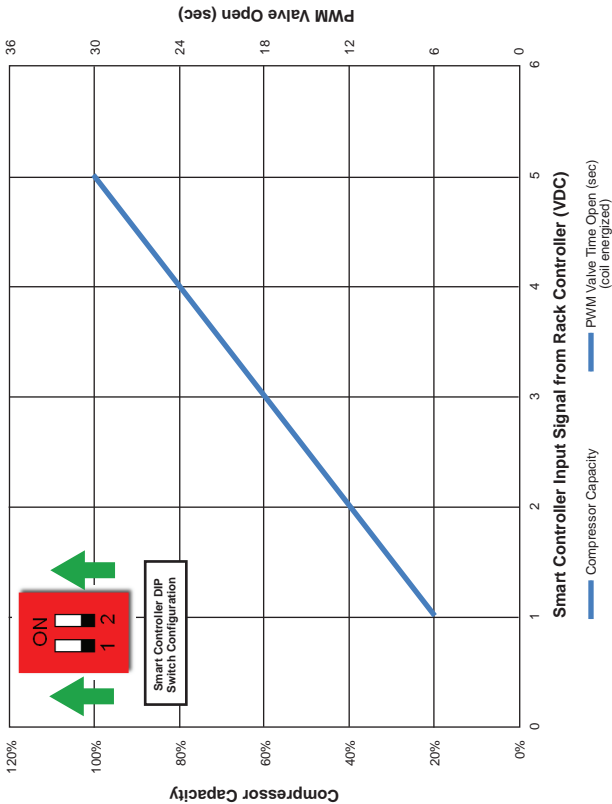

Fig. 43 — System/Rack Controller Curve

SERVICE TABLE

Use this service table to verify that the PWM valve is modulating correctly per the applied voltage signal to the smart controller.

SMART CONTROLLER	06D, 06CC, 06M COMPRESSOR CAPACITY	PWM VALVE
Demand Signal Input (vdc)	Percentage	Solenoid Coil Energized (sec)
1.0	20%	6
1.5	30%	9
2.0	40%	12
2.5	50%	15
3.0	60%	18
3.5	70%	21
4.0	80%	24
4.5	90%	27
5.0	100%	30

SERVICE GUIDE INDEX

	Page
06CC (16 to 37 Cfm) 3 Phase Electrical Specifications.....	113
06CC (50 to 99 Cfm) 3 Phase Electrical Specifications.....	115
06CC (16 to 37 Cfm) Torque Guide.....	60
06CC (50 to 99 Cfm) Torque Guide.....	61
06CC Compressor 16 to 37 Cfm Model, Connection Points — Motor End.....	51
06CC Compressor 16 to 37 Cfm Model, Connection Points — Pump End.....	50
06CC Compressor 50 to 99 Cfm Model, Connection Points — Motor End.....	53
06CC Compressor 50 to 99 Cfm Model, Connection Points — Pump End.....	52
06CC Compressor Model Numbers.....	5
06CC Compressors — Physical Data.....	66, 67
06CC Service Worksheet.....	138
06D 2-Cylinder Compressor, Connection Points.....	44
06D 4-Cylinder Compressor (13 and 16 Cfm), Connection Points.....	45
06D 4-Cylinder Compressor (18 and 20 Cfm), Connection Points.....	46
06D 6-Cylinder Compressor (25, 28, 37 and 41 Cfm), Connection Points.....	47
06D 6-Cylinder Compressor, Exploded View.....	56
06D Compressor, Cross-Sectional View.....	54
06D and 06CC (16-37 Cfm) Electronic Overcurrent Protection.....	117
06D Compressor Model Numbers.....	3
06D Compressors — Physical Data.....	62, 63
06D Compressors — Torque Guide.....	60
06D Electromechanical Overcurrent Protection.....	116
06D, E Service Worksheet.....	137
06DM, DA 3 Phase Electrical Specifications.....	104
06DR 3 Phase Electrical Specifications.....	102
06DR, DM Single-Phase Electrical Specifications.....	106
06E 4-Cylinder Compressor (50 and old 66 Cfm), Connection Points.....	48
06E 6-Cylinder Compressor (65, 75, 99 Cfm), Connection Points.....	49
06E 6-Cylinder Compressor, Exploded View.....	58
06E Compressor, Cross-Sectional View.....	55
06E Compressor Model Numbers.....	4
06E Compressors — Physical Data.....	64, 65
06E Compressors — Torque Guide.....	61
06EA, ET 3 Phase Electrical Specifications.....	111
06EM, EZ 3 Phase Electrical Specifications.....	109
06ER, EY 3 Phase Electrical Specifications.....	107
Additives, Oil.....	72
Alkylbenzene Oil, Use with CFC.....	71
Baffle Plates.....	98
Bearing Head (Oil Pump), Replacement Procedures.....	39
Bearing Head, High Flow Oil Pump.....	73
Bearing Head, Pump End.....	39
Bearing Head, Replacement.....	38
Billing and Credit.....	9
Capacity Control Unloading Accessory Packages.....	87
Capacity Control Coil Packages.....	89
CFCs, Approved for Use.....	70

Cfm Designation	5
Clean-Up	41
Compressor Isolation	21
Compressor Model Number Significance	3
Compressor Mounting Data	91
Compressor Problems — see “Troubleshooting”	20
Compressors without Oil	68
Connection Points, 06CC 16 to 37 Cfm Models	50, 51
Connection Points, 06CC 50 to 99 Cfm Models	52, 53
Connection Points, 06D 2-Cylinder Models	44
Connection Points, 06D 4-Cylinder Models	45, 46
Connection Points, 06D 6-Cylinder Model	47
Connection Points, 06E 4-Cylinder Models	48
Connection Points, 06E 6-Cylinder Models	49
Crankcase Heaters	90
Current Unbalance	135
Cycling, Continuous — Typical Causes	24
Cycling, Intermittent — Typical Causes	23
Cylinder Head, Blown	23
Cylinder Head Cooling Fans	86
Cylinder Head Disassembly	33
Cylinder Head Gasket — Failure Causes	23
Cylinder Head Gaskets	93
Cylinder Head Reassembly	36
Discharge Gas Temperature Sensor	85
Electrical Hookup, 06D & 06CC (17-37 Cfm) Compressors	130
Electrical Hookup, 06E Compressors — Across-the-Line Start	133
Electrical Hookup, 06E Compressors — Part Winding Start	134
Electrical Schematic, Compressors with 1 Unloading Head or PWM Valve	152
Electrical Schematic, Compressors with 2 Unloading Heads	150
Electrical Specifications	102
Electronic Oil Pressure Safety Switch	75
Electronic Overcurrent Protection — Service Replacement Kit	118
Electronic Overcurrent Protection — Service Retrofit Kit (Single-Phase)	129
Electronic Overcurrent Protection — Service Retrofit Kit (Three-Phase)	125
Flooding — Typical Causes	24
Gasket, Sensor Block	94
Gasket, Terminal Plate	94
Gaskets, Cylinder Head and Valve Plates	93
Gaskets, Service Valves	91
Gaskets, Leak Testing	32
Heaters, Crankcase	90
Help — Where to Get More	1
HFCs, Approved for Use	69
High Efficiency Compressors, 06D, E	68
Insertion Heaters	90
Interstage Pressure Tables (06CC)	98
Jumper Plate Packages Connection	97
Locked Rotor, Cycling On — Typical Causes	27
Low Compressor Capacity	22

Metric Conversions and Measurements	5
Mineral Oils, To Use With CFC Refrigerants	71
Model Number	3, 6
Motor Burnout	27
Motor Barrel Interconnection	14
Motor End Mounting Foot	92
Motor Burnout — Clean-up Procedure	41
Motor Protection Tripping — Typical Causes	26
Mounting Data, Compressor	91
Mounting Plate, Compressors	91
Mufflers	96
Nameplate Significance	6
OEM	9, 10
Oil Additives	72
Oil Charge	63
Oil Control — Parallel Compressor Applications	13, 28
Oil Control — Motor Barrel Interconnections	14
Oil Drain Plug Adapter	92
Oil Level in Sight Glass	12
Oil Operating Levels	12
Oil Pressure	72
Oil Pressure Problems — Typical Causes	25
Oil Pressure Safety Switch	74
Oil Pressure Safety Switch LED Flash Codes	83
Oil Pressure Safety Switch Operation	76
Oil Pressure Safety Switch Technical Specifications	82
Oil Pressure Safety Switch Wiring Diagram	82
Oil Pump — See Bearing Head	
Oil Sensor Block Installation	78
Oil Viscosity and Pour Points	71
Oils, Approved for Use	69
Operating Limits, Typical — 06CC	19
Operating Limits, Typical — 06D, E	18
Overcurrent Protection for 06D Compressors	116
Parallel Compressor Applications, Oil Control	28
Parts Identification — 06D Compressor, Exploded View	56
Parts Identification — 06E Compressor, Exploded View	58
Physical Data — 06CC Compressors	66
Physical Data — 06D Compressors	62
Physical Data — 06E Compressors	64
Pipe Rattles — Typical Causes	25
Piston, Suction Valve, and Backer Positions	36
POE Oils, To Use with HFC Refrigerants	69
Pump End Bearing Head	39
Pre Start-Up Procedures	11
PWM Valve	154
PWM Valve Configuration	158
PWM Valve Installation and Operation	155
PWM Valve Service Table	160
Rated Load Amps (RLA)	102

Refrigerants and Oils for 06CC Compressors	69
Refrigerants and Oils for 06D, E Compressors.....	69
Sensor Block Gasket	94
Serial Number	8
Service Billing	9
Service Procedures	32
Service Procedures — Bearing Head (Oil Pump).....	38
Service Procedures — Cylinder Head and Valve Plate Assembly	32
Service Procedures — Motor Burnout Clean Up	41
Service Replacement Kits.....	118
Service Retrofit Kits (Single-Phase)	129
Service Retrofit Kits (Three-Phase)	125
Service Table, PWM Valve	160
Service Valve Gaskets.....	91
Service Valves	91
Service Worksheet, 06CC	138
Service Worksheet, 06D, E.....	137
Sight Glass Adapters — Oil Equalization	92
Sight Glass, Oil Level	12
Sight Glass Replacement — Installation Tool	92
Smart Controller.....	139
Smart Controller Compressor Capacity	149
Smart Controller Configuration	148
Smart Controller Functional Overview	139
Smart Controller Identification	140
Smart Controller Inputs and Outputs	141
Smart Controller Service Table.....	153
Special Order Number.....	6
Start-Up — Before Starting.....	11
Start-Up — Recommended Procedures	11
Start-Up, Compressor	15
Start-Up, Troubleshooting and Service.....	10
Start-Up, Will Not Start	22
Strap-On Heaters.....	90
Suction Cut-Off Control.....	87
Suction Valve.....	36
Technical Assistance, OEM	10
Terminal Lug Package.....	97
Terminal Plate Gasket	94
Terminal Plate Jumper Bars, 06E 06CC (50 to 99 Cfm).....	97
Terminal Posts.....	134
Torque Guide — 06D and 06CC (16 to 37 Cfm) Compressors	60
Torque Guide — 06E and 06CC (50 to 99 Cfm) Compressors	61
Troubleshooting	20
Troubleshooting — 06CC Desuperheater Connection Hot.....	30
Troubleshooting — 06CC Discharge Pressure = Intermediate Pressure	31
Troubleshooting — 06CC Economizer Connection Hot.....	30
Troubleshooting — 06CC High Midstage Pressure	30
Troubleshooting — 06CC Intermediate Pressure = Discharge Pressure	31
Troubleshooting — 06CC Low Midstage Pressure.....	30

COMPLIMENTS OF:

Carlyle service replacement compressors, parts, and support are available through a wide distribution network. **Technical support is provided by your local distributor.** Customer Service Representatives can provide assistance in locating your nearest distributor.

USA
800-Go-Carlyle
(800-462-2759)
www.Totaline.com



CANADA
800-668-7905
www.wwgtotaline.ca/en/branch



MEXICO
01 800 171 11 11
www.totalinecom.mx/pages/Sucursales.html



www.CarlyleCompressor.com
© Carrier Corporation 2018

Manufacturer reserves the right to discontinue, or change at any time, specifications or designs without notice or without incurring obligations.