

CAT NO 580-572

CODES: 111

COMPRESSOR

JOB NAME \_\_\_\_\_  
 JOB LOCATION \_\_\_\_\_  
 BUYER \_\_\_\_\_  
 BUYER NO. \_\_\_\_\_ CARRIER NO. \_\_\_\_\_  
 DIMENSIONS CERTIFIED BY \_\_\_\_\_ DATE \_\_\_\_\_

MARK FOR \_\_\_\_\_  
 PART NO. \_\_\_\_\_ TYPE DRIVE:  DIRECT  BELT  
 RPM \_\_\_\_\_ DESIGN BHP INPUT \_\_\_\_\_ MOTOR HP \_\_\_\_\_  
 SAT SUCTION TEMP \_\_\_\_\_ F. SAT DISCHARGE TEMP \_\_\_\_\_ F  
 REFRIGERATION EFFECT \_\_\_\_\_ TONS. REFRIGERANT NO. \_\_\_\_\_

NOTES:

1. SHAFT DETAIL DRAWING 5F-531
2. COMPRESSOR MAY BE OPERATED IN EITHER DIRECTION OF ROTATION. STANDARD ROTATION IS COUNTER CLOCKWISE LOOKING FROM THE PUMP END; FOR REVERSE ROTATION ROTATE OIL PUMP 180°.
3. NET WEIGHT 355LBS. INCLUDES OIL BUT NOT REFRIGERANT CHARGE.

	YES	NO
FLYWHEEL	<input type="checkbox"/>	<input type="checkbox"/>
WATER COOLED HEADS	<input type="checkbox"/>	<input type="checkbox"/>
CRANKCASE COVER PLATES FOR COMPRESSOR INTERCONNECTION	<input type="checkbox"/>	<input type="checkbox"/>

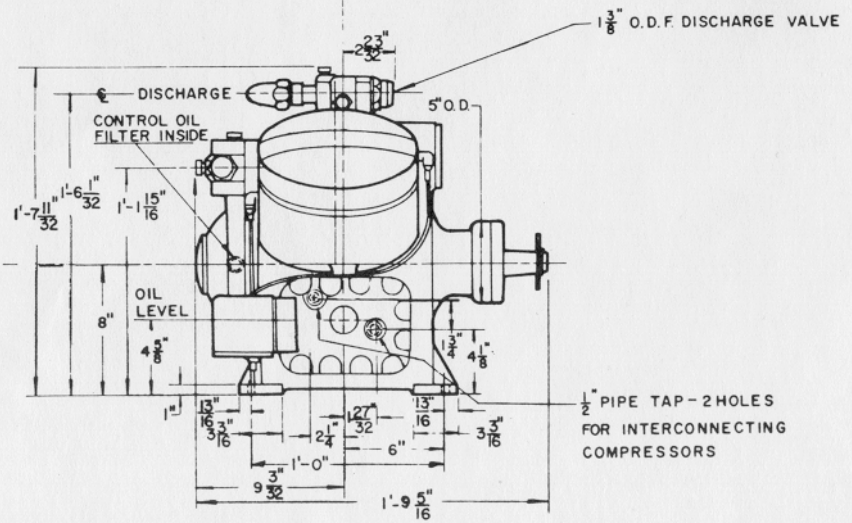
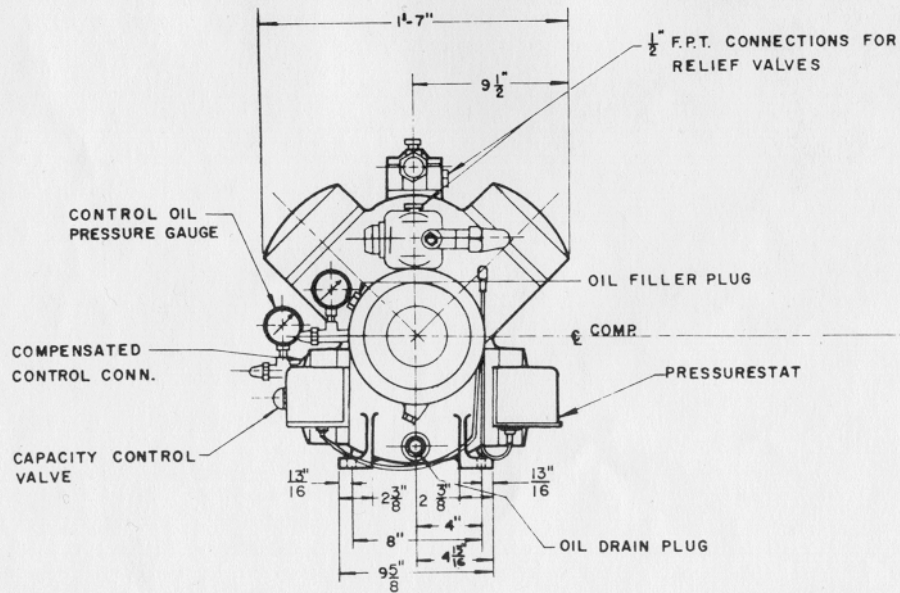
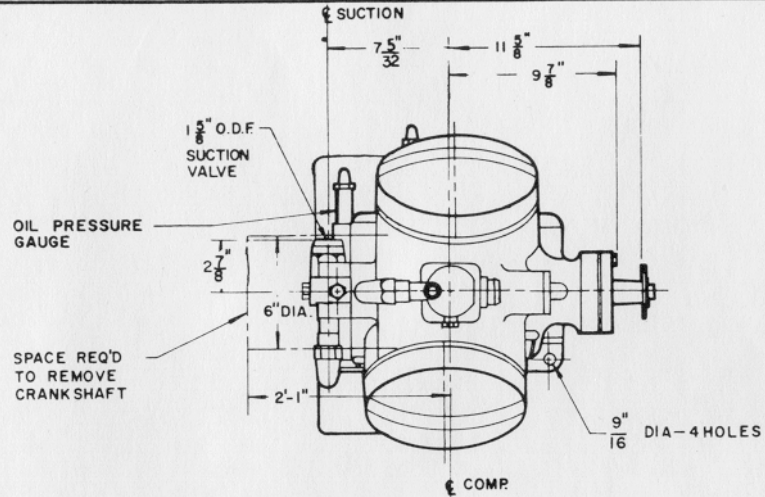

THIS DRAWING IS THE PERSONAL PROPERTY OF  
 CARRIER AIR CONDITIONING COMPANY  
 DIVISION OF CARRIER CORPORATION, SYRACUSE, N.Y.  
 ALL USE IS FORBIDDEN EXCEPT ON ITS WRITTEN CONSENT

5F

DR. S. M. S.	TR. G. R. C.	DATE 8-30-76
CHK. C. E. D.	APPD. C. E. D.	SUPERSEDES ISSUE OF 5-10-61

5F40 COMPRESSOR ASSEMBLY

5F-040

REV. A