

# Installation Instructions

**NOTE:** Read the entire instruction manual before starting the installation.

## SAFETY CONSIDERATIONS

Improper installation, adjustment, alteration, service, maintenance, or use can cause explosion, fire, electrical shock, or other conditions which may cause death, personal injury, or property damage. Consult a qualified installer, service agency, or your distributor or branch for information or assistance. The qualified installer or agency must use factory-authorized kits or accessories when modifying this product. Refer to the individual instructions packaged with the kits or accessories when installing.

Follow all safety codes. Wear safety glasses, protective clothing, and work gloves. Use quenching cloth for brazing operations. Have fire extinguisher available. Read these instructions thoroughly and follow all warnings or cautions included in literature and attached to the unit. Consult local building codes and current editions of the National Electrical Code (NEC) NFPA 70. In Canada, refer to current editions of the Canadian electrical code CSA 22.1.

Recognize safety information. This is the safety-alert symbol . When you see this symbol on the unit and in instructions or manuals, be alert to the potential for personal injury.

Understand the signal words DANGER, WARNING, and CAUTION. These words are used with the safety-alert symbol. DANGER identifies the most serious hazards which **will** result in severe personal injury or death. WARNING signifies hazards which **could** result in personal injury or death. CAUTION is used to identify unsafe practices which **may** result in minor personal injury or product and property damage. NOTE is used to highlight suggestions which **will** result in enhanced installation, reliability, or operation.

## WARNING

### ELECTRICAL SHOCK HAZARD

Failure to follow this warning could result in personal injury or death.

Before installing, modifying, or servicing system, main electrical disconnect switch must be in the OFF position. There may be more than 1 disconnect switch. Lock out and tag switch with a suitable warning label.

Use only the kit components described in this installation procedure.

## INTRODUCTION

These instructions cover the installation of Start Capacitor/Relay Kits on split-system air conditioners and heat pumps.

### Kit contents:

- Relay - 1
- Capacitor - 1
- Capacitor strap - 1
- Screws - 3
- Black wire - 1
- Blue wire - 1
- Brown wire - 1
- Yellow wire - 1
- Terminal covers (some kits only - see Table 1) - 5
- Installation Instructions - 1

## CAUTION

### ELECTRICAL OPERATION HAZARD

Failure to follow this caution may result in equipment damage or improper operation.

Care must be exercised when drilling kit mounting holes to avoid damage to wires and other existing electrical and refrigerant components.

## INSTALLATION

**NOTE:** Remove and discard start thermistor if used.

### Run Capacitor Mounted In Vertical Position (See Fig. 1, 2, 4, 5, and 6)

1. Remove 2 screws located above and right of run capacitor (Fig. 2 units only).
2. Attach start capacitor strap to start capacitor.
3. Attach start capacitor and strap assembly to control box as shown in appropriate figure. Use screw provided.
4. Attach start relay. Locate relay tab in dimple of control box. Use screw provided.
5. Connect black wire to terminal 5 on start relay and terminal 21 on contactor.
6. Connect blue wire to terminal 2 on start relay and 'H' on unit run capacitor.
7. Connect brown wire to terminal 1 on start relay and start capacitor.
8. Connect yellow wire to start capacitor and 'C' on run capacitor.
9. Installation is complete. Proceed to Step 4—Unit Start-Up.

### Run Capacitor Mounted In Horizontal Position (See Fig. 1, 3, 4, 5 and 6)

1. Remove 2 screws above run capacitor.
2. Attach start relay to top center of control box. Locate relay tab in dimple of control box. Use screw provided.
3. Attach start capacitor strap to start capacitor with flap pointing down and capacitor terminals pointing left.
4. Attach start capacitor and strap assembly to control box above run capacitor. Use provided screw.
5. Connect black wire to terminal 5 on start relay and terminal 21 on contactor.
6. Connect blue wire to terminal 2 on start relay and 'H' on unit run capacitor.
7. Connect yellow wire to start capacitor and 'C' on unit run capacitor.
8. Installation is complete. Proceed to Unit Start-Up.

### Run Capacitor Mounted In Vertical Position (See Fig. 1, 7 and 8) for Evolution/Infinity Systems in Cube Cabinet.

1. Attach start capacitor strap to start capacitor. Start capacitor will face downward and the mounting tab will be to the left-hand side. See Fig. 7.
2. Attach start capacitor and strap assembly to the control box as shown in Fig. 7 using the holes shown in Fig. 8. Two (2) screws are provided with kit to mount the capacitor strap.
3. Attach start relay to control box as shown in Fig. 7 using one of the screws provided. Locate the tab on the back of the relay against the corner specified in Fig. 8.
4. Connect flag terminal of black wire to terminal 5 on start relay and the piggyback straight terminal to terminal 21 on contactor. Connection to terminal 5 on start relay should be made to tab closest to contactor to provide maximum clearance between relay and control box door.
5. Connect flag terminal of blue wire to terminal 2 on start relay and the straight terminal to 'H' on unit run capacitor.
6. Connect flag terminal of brown wire to terminal 1 on start relay and the straight terminal to start capacitor.
7. Connect yellow wire to start capacitor and 'C' on the run capacitor.
8. Place provided terminal covers on three unused terminals on the start relay and two unused terminals on the start capacitor.
9. Installation is complete. Proceed to Unit Start-Up.

### Unit Start-up

1. Check all electrical connections for proper position.
2. Check system pressures for equalization.
3. Restore power to unit and start compressor.  
Should the compressor fail to start, check unit wiring. Power supply must be within operating voltage range indicated on unit rating plate.

**Table 1—Kit Components**

KIT NUMBER	START RELAY	START CAPACITOR	MICROFARAD/VOLTAGE	TERMINAL COVER
KSAHS0901AAA	HN61HB543	HC95DE020	145–174/330	No
KSAHS1001AAA	HN61HB541	HC95DE020	145–174/330	No
KSAHS1101AAA	HN61HB540	HC95DE020	145–174/330	No
KSAHS1201AAA	HN61HB542	HC95DE012	135–155/330	No
KSAHS1301AAA	HN61HB542	HC95DE090	189–227/330	No
KSAHS1401AAA	HN61HB542	HC95DE088	88–108/330	No
KSAHS1501AAA	HN61HB540	HC95DE088	88–108/330	No
KSAHS1601AAA	HN61HB540	HC95DE297	270–324/330	No
KSAHS1701AAA	HN61HB540	HC95DE045	176–216/330	No
KSAHS1801AAA	HN61HB544	HC95DE297	270–324/330	No
KSAHS1901AAA	HN61HB545	HC95DE297	270–324/330	No
KSAHS2001AAA	HN61HB545	HC95DE020	145–174/330	No
KSAHS2101AAA	HN61HB546	HC95DE020	145–174/330	No
KSAHS2201AAA	HN61HB541	HC95DE090	145–174/330	No
KSAHS2301AAA	HN61HB551	HC95DE088	88–108/330	Yes
KSAHS2401AAA	HN61HB550	HC95DE088	88–108/330	Yes
KSAHS2501AAA	HN61HB540	HC95DE088	88–108/330	Yes
KSAHS2601AAA	HN61HB551	HC95DE297	270–324/330	Yes
KSAHS2701AAA	HN61HB540	HC95DE045	176–216/330	Yes
KSAHS2801AAA	HN61HB553	HC95DE088	88–108/330	Yes

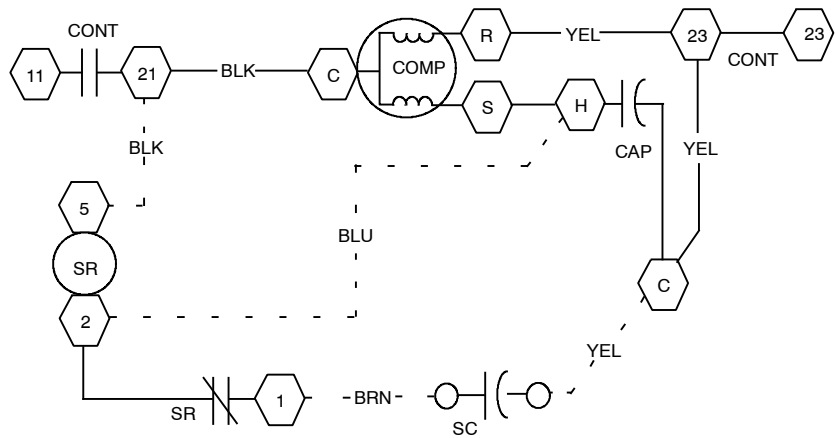

- FACTORY WIRING
- - - - FIELD INSTALLED WIRING
- COMP COMPRESSOR
- SR START RELAY
- SC START CAPACITOR
- CAP RUN CAPACITOR
- CONT CONTACTOR

A96112

**Fig. 1 - Electrical Connections**

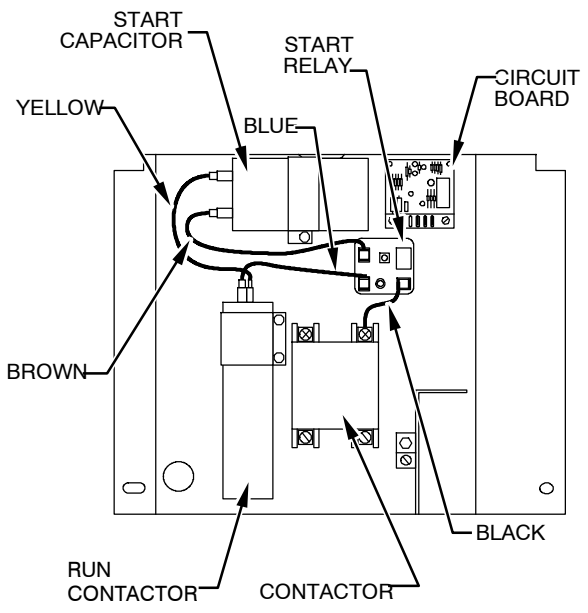

A99089

**Fig. 2 - Run Capacitor Mounted in Vertical Position**

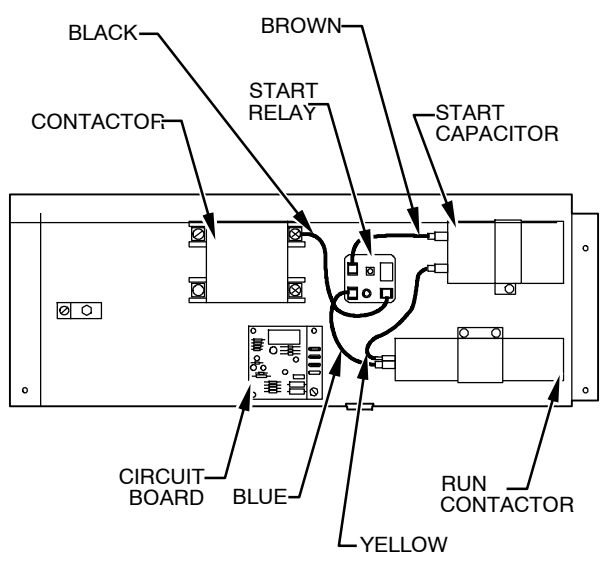

A99090

**Fig. 3 - Run Capacitor Mounted in Horizontal Position**

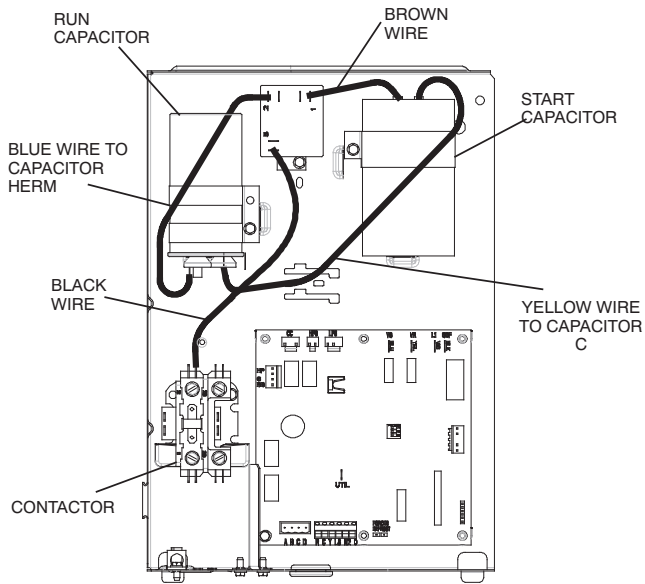

**Fig. 4 - Start Kit Components, Performance / Preferred**

A06071

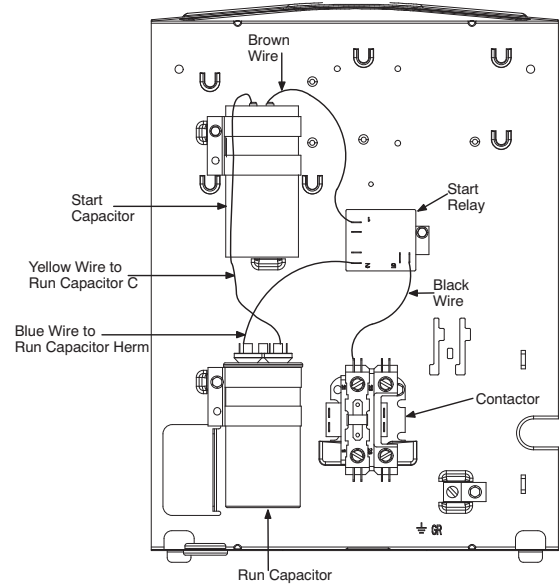

**Fig. 5 - Start Kit Components, Base / Legacy / Comfort**

A12218

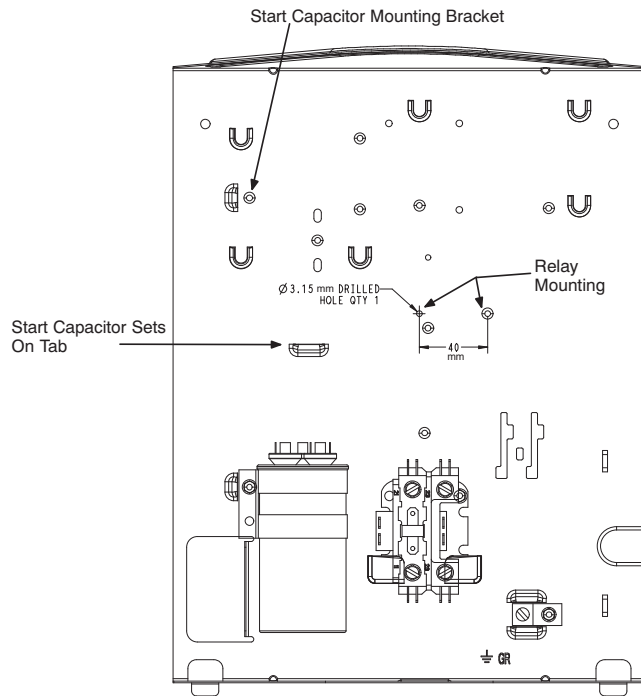

**Fig. 6 - Start Relay & Start Capacitor Mounting Locations Base / Legacy / Comfort**

A12219

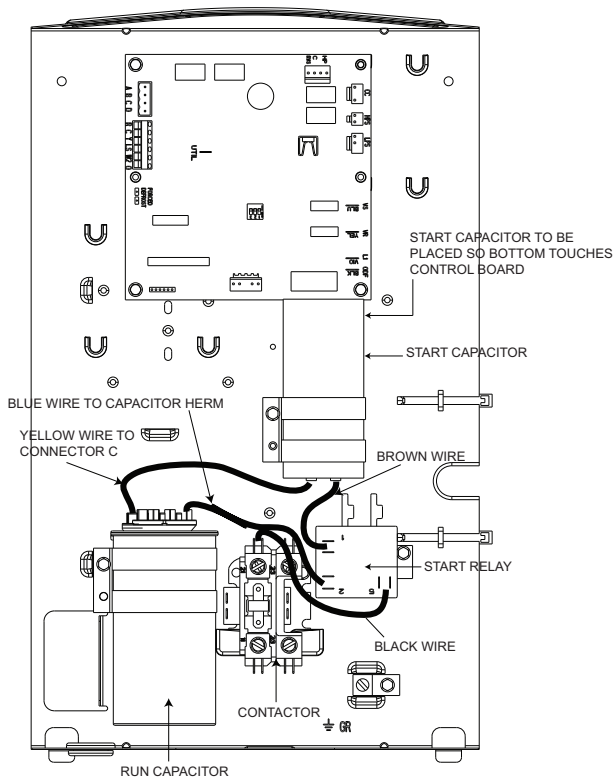

**Fig. 7 - Start Kit Components,  
Evolution / Infinity in Cube Cabinet**

A10156

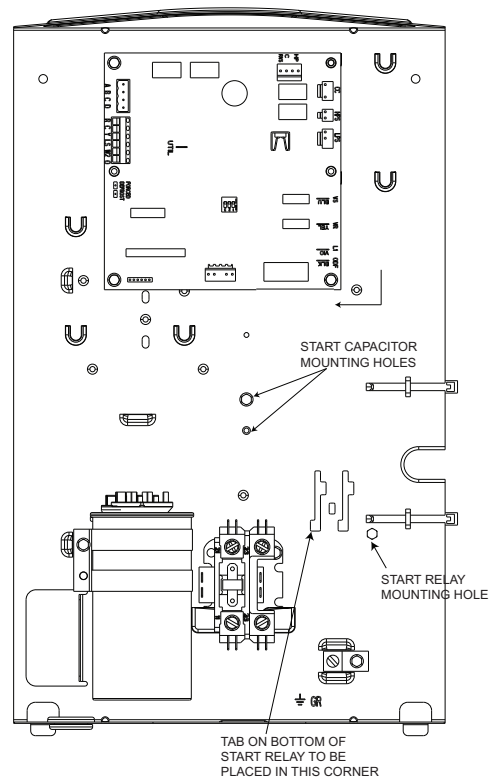

**Fig. 8 - Start Relay and Capacitor Mounting Locations  
Evolution / Infinity in Cube Cabinet**

A10157

