

**PART NUMBER:
CPLOWAMB001A00
CPLOWAMB002A00**

**SMALL PACKAGED PRODUCTS
2 TO 5 TONS (50/60 HZ)
MOTORMASTER II HEAD PRESSURE CONTROLLER**

Installation Instructions

NOTE: Read the entire instruction manual before starting the installation.

SAFETY CONSIDERATIONS

Installation and servicing of this equipment can be hazardous due to mechanical and electrical components. Only trained and qualified personnel should install, repair, or service this equipment.

Untrained personnel can perform basic maintenance functions such as cleaning and replacing air filters. All other operations must be performed by trained service personnel. When working on this equipment, observe precautions in the literature, on tags, and on labels attached to or shipped with the unit and other safety precautions that may apply.

Follow all safety codes. Installation must be in compliance with local and national building codes. Wear safety glasses, protective clothing, and work gloves. Have fire extinguisher available. Read these instructions thoroughly and follow all warnings or cautions included in literature and attached to the unit. In Canada, refer to current editions of the Canadian electrical code CSA 22.1 and current editions of the National Electrical Code (NEC) NFPA 70.

Recognize safety information. This is the safety-alert symbol . When you see this symbol on the unit and in instructions or manuals, be alert to the potential for personal injury. Understand these signal words; DANGER, WARNING, and CAUTION. These words are used with the safety-alert symbol. DANGER identifies the most serious hazards which **will** result in severe personal injury or death. WARNING signifies hazards which **could** result in personal injury or death. CAUTION is used to identify unsafe practices which **may** result in minor personal injury or product and property damage. NOTE is used to highlight suggestions which **will** result in enhanced installation, reliability, or operation.

Follow all safety codes. Wear safety glasses and work gloves. Have a fire extinguisher available.

WARNING

ELECTRICAL SHOCK HAZARD

Failure to follow this warning could cause personal injury or death.

Before performing service or maintenance operations on unit, turn off main power switch to unit and install lockout tag. Ensure electrical service to rooftop unit agrees with voltage and amperage listed on the unit rating plate.

INTRODUCTION

These instructions cover the installation of the Motormaster II Controller head pressure control device. Refer to the Installation section for directions. Louvered panels are required for this installation; see Item 9 in the Installation section of this document and Tables 1 and 2 for more information.

Table 1 – Add Louvered Panels to These Units if available. If Louvered Panel kit is not available for a specific model, Field Fabricated Wind Baffles are recommended.

48ES-A	574D--A	PGD3	PY3G	WPG3
50ES-A	704D--A	PAD3	PA3G	WPA3
48EZ-A	674D--A	PDD3	-	-
50EZ-A	604D--A	PHD3	PH3G	WPH3
48VL-B	577C--B	-	-	-
50VL-B	707C--B	-	-	-
48VT-B	677C--B	-	-	-
50VT-B	607C--B	-	-	-
48VL-C	577C--C	PY4G-A	PGD4-E PGS4-E	WPG4-B
50VL-C	707C--C	PA4G-A	PAD4-E	WPA4-B
48VT-C	677C--C	-	PDD4-E PDS4-E	-
50VT-C	607C--C	PH4G-A	PHD4-F	WPH4-B

Table 2 – Do NOT Add Louvered Panels to These Units

50ZHC	PH4Z	PHJ4	PH4Z	WJH4
50ZPC	PA4Z	PAJ4	PA4Z	WJA4
48VG	577E	-	PGR5	
50VG	707E	-	PAR5	
48VR	677E	-	-	
50VR	607E	-	PHR5	

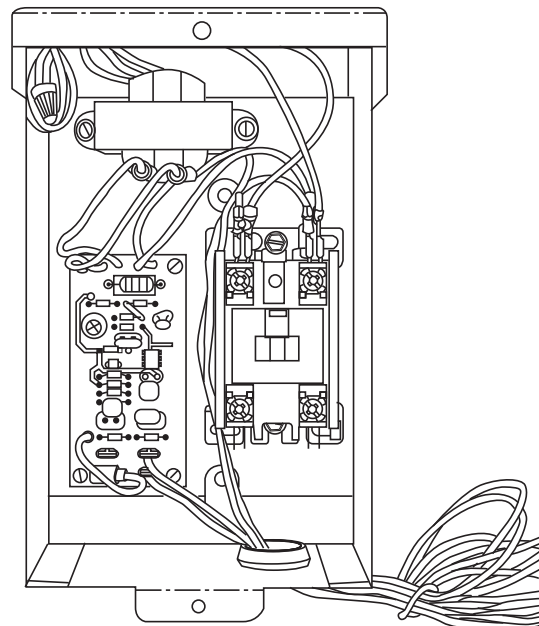

Motormaster® II Controller Interior

Fig. 1 - Controller Interior

C00102

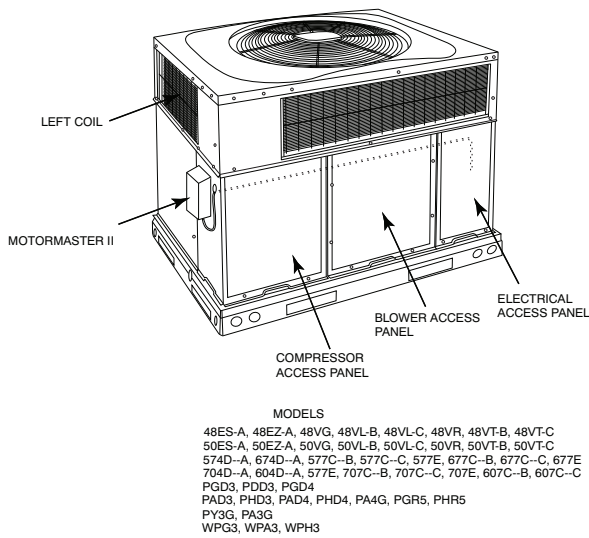

A11089B

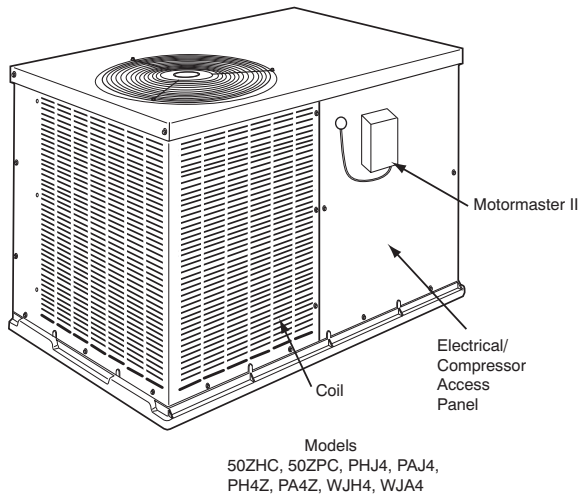

A11090B

Fig. 2 - Access Panel and Motormaster Location

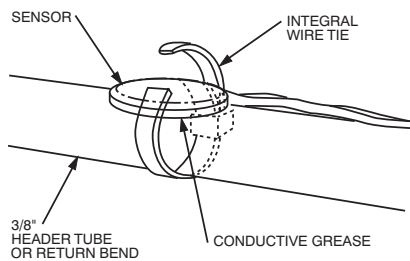

NOTE: INSTALLED SENSOR MUST BE LEFT UNINSULATED.

Sensor Connection Details

A11106

Fig. 3 - Connection Details

DESCRIPTION AND USAGE

The Motormaster II head pressure controller is a cycle control device activated by a temperature sensor mounted on a header tube of the outdoor coil (see Fig. 1). It is designed to cycle the outdoor-fan motors to maintain the saturated condensing temperature within normal operating limits of approximately 130 to 110°F high (54°C to 43°C), 70 to 50°F low (21 to 10°C). The controller maintains working head pressure at low ambient temperatures down to -20°F (-29°C) when properly installed.

⚠ CAUTION

CUT HAZARD

Failure to follow this caution may result in personal injury. Sheet metal parts may have sharp edges or burrs. Use care and wear appropriate protective clothing and gloves when handling parts.

INSTALLATION

1. Disconnect power to unit. Install lockout tag.
2. Remove unit electrical, blower and compressor access panel. (See Fig. 2.)
3. Disconnect black lead from the outdoor-fan motor (OFM) and connect to Motormaster control (See Wiring Schematic, Fig. 7 or 8).
4. Using a knockout punch and die combination, make hole in the access panel to feed MotormasterII Control wire leads to the side of its mounting location (See Fig. 2 and Fig. 4 or Fig. 5).

NOTE: Field-supplied conduit must be used between controller and access panel (or wire into unit entrance). Created hole on the access panel must be sealed to comply with National Electric Code (NEC).

5. Mount Motormaster II Controller on unit. Refer to Fig. 2 and Fig. 4 or Fig. 5, The controller must be mounted vertically with the leads at the bottom. Using the Mounting Template (Fig. 9) as a guide, drill mounting holes. To ensure electrical ground, insert star washers (supplied with the controller) under the heads of mounting screws.
6. Determine sensor location by referring to Fig. 10-NO TAG. Route sensor wire through bottom of Motormaster II Controller (Fig. 1) to sensor location specified. Prior to installation, apply conductive grease supplied with accessory to contact surface of sensor.

⚠ CAUTION

COMPONENT DAMAGE HAZARD

Failure to follow this caution may result in component damage. Sensor assembly is delicate. Handle with care.

7. Attach sensor to tube as shown in Fig. 3. Installed sensor must be left uninsulated.
8. Power wiring must comply with all local and National Electrical Code (NEC) and International Electric Code (IEC) requirements. Refer to Fig. 7 and 8 for power wiring connections. Coil up all excess wire and secure. (Yellow and blue wires, from controller, must run to unit contactor and connect on the load side.)

⚠ CAUTION

UNIT OPERATION AND COMPONENT DAMAGE HAZARD

Failure to follow this caution may result in improper unit operation or component damage. All wires must be secured so that they are not in contact with unit tubing.

9. To prevent wind cross-currents from causing abnormally low condensing temperatures, louvered panels are required on some models. See Table 1 and 2 for models requiring/not requiring louvered panels.
10. Screw back all access panels
11. Reconnect power to the unit.

The Motormaster II head pressure controller is equipped with an alternate operating mode. When this mode is selected, the controller shifts the fan cycle sequence to effectively raise the

average condensing temperature approximately 20°F (-6.7°C) higher than the standard operating mode. In this alternate mode, the outdoor fan begins cycling at higher outdoor ambient temperatures. This mode should only be used if the evaporator coil shows signs of frosting at low outdoor ambient temperatures. To select the alternate operating mode, move the jumper wire on the Motormaster II control board from reset T1 to T2. Refer to Fig. 6 for thermistor resistance vs. temperature.

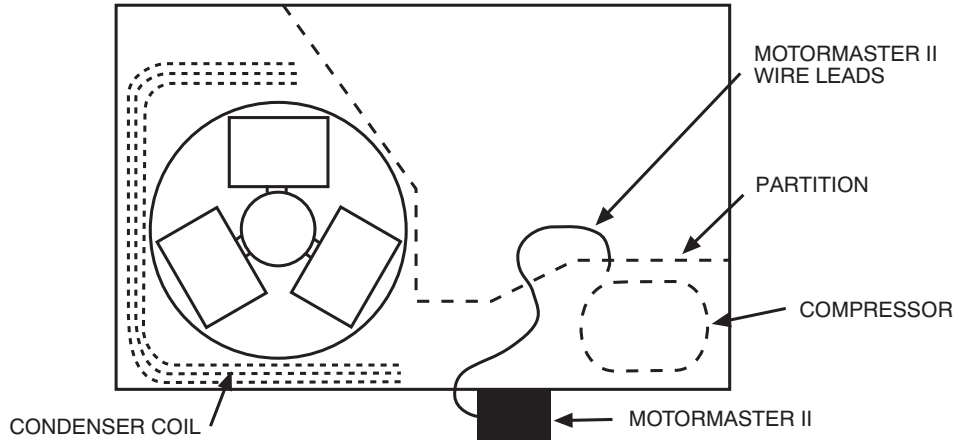

See Step 4 to make hole in access panel.

50ZHC, 50ZPC, PAJ4, PHJ4, PA4Z, PH4Z, WJA4, WJH4

Fig. 4 - Mounting Locations

A11087B

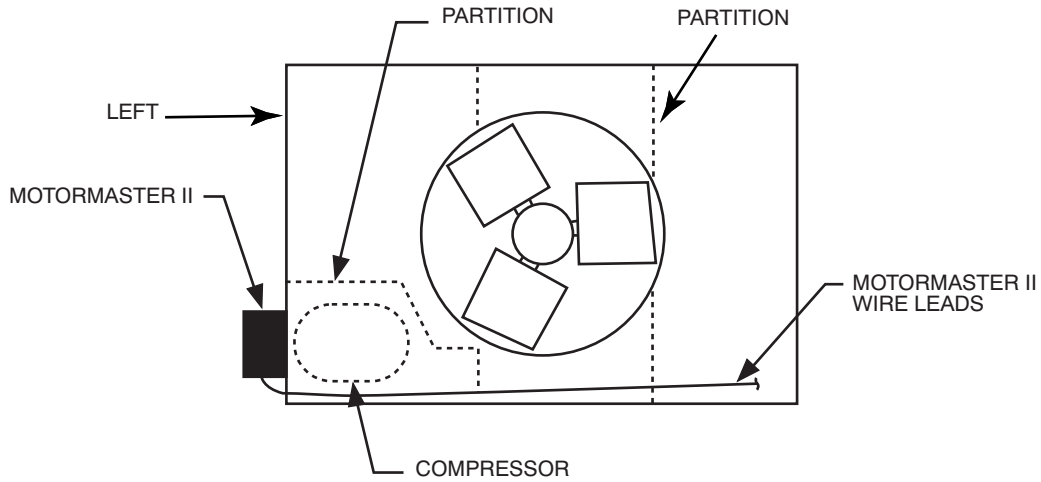

48ES-A, 48EZ-A, 48VG, 48VR, 48VL-B, 48VT-B
 50ES-A, 50EZ-A, 50VG, 50VR, 50VL-B, 50VT-B
 574D--A, 577E, 607E, 674D--A, 577C--B, 577C--C, 677C--B, 677C--C
 677E, 704D--A, 707E, 604D--A, 707C--B, 707C--C, 607C--B, 607C--C
 PAR5, PGR5, PHR5, PGD3, PDD3, PAD3, PHD3, PAD4, PGD4, PHD4
 PA3G, PY3G, PH3G, WPA3, WPG3, WPH3

Fig. 5 - Mounting Locations

A11088B

Table 3 – Sensor Location Index

MODEL NUMBER	MODEL NUMBER	MODEL NUMBER	MODEL NUMBER	MODEL NUMBER	FIGURE NUMBER
48ES–A 50ES–A	574D--A 704D--A	PGD3 PAD3	PY3G PA3G	WPG3 WPA3	Fig. 10
					Fig. 11
					Fig. 12
					Fig. 13
					Fig. 14
48EZ–A 50EZ–A	674D--A 604D--A	PDD3 PHD3	PH3G	WPH3	Fig. 15
					Fig. 16
					Fig. 17
					Fig. 18
					Fig. 19
48VL–B 50VL–B	577C--B 707C--B	PGD4 PAD4	– –	– –	Fig. 20
					Fig. 21
					Fig. 22
					Fig. 23
					Fig. 24
48VT–B 50VT–B	677C--B 607C--B	– PHD4	– –	– –	Fig. 25
					Fig. 26
					Fig. 27
					Fig. 28
					Fig. 29
48VG 50VG	577E 707E	PG4R PAR5	–	–	Fig. 30
					Fig. 31
					Fig. 32
					Fig. 33
					Fig. 34
48VL–C 50VL–C	577C--C 707C--C	PGD4 PGS4 PAD4	PY4G PA4G	WPG4 WPA4	Fig. 35
					Fig. 36
					Fig. 37
					Fig. 38
					Fig. 39
48VT–C 50VT–C	677C--C 607C--C	PDD4 PHD4	– PH4G	– WPH4	Fig. 40
					Fig. 41
					Fig. 42
					Fig. 43
					Fig. 44
48VR 50VR	677E 607E	– PHR5	–	–	Fig. 45
					Fig. 46
					Fig. 47
					Fig. 48
					Fig. 49
50ZHC	PH4Z	PHJ4	PH4Z	WJH4	Fig. 50
					Fig. 51
					Fig. 52
					Fig. 53
					Fig. 54
50ZPC	PA4Z	PAJ4	PA4Z	WPA4	Fig. 55
					Fig. 56
					Fig. 57
					Fig. 58
					Fig. 59

CPLOWAMB

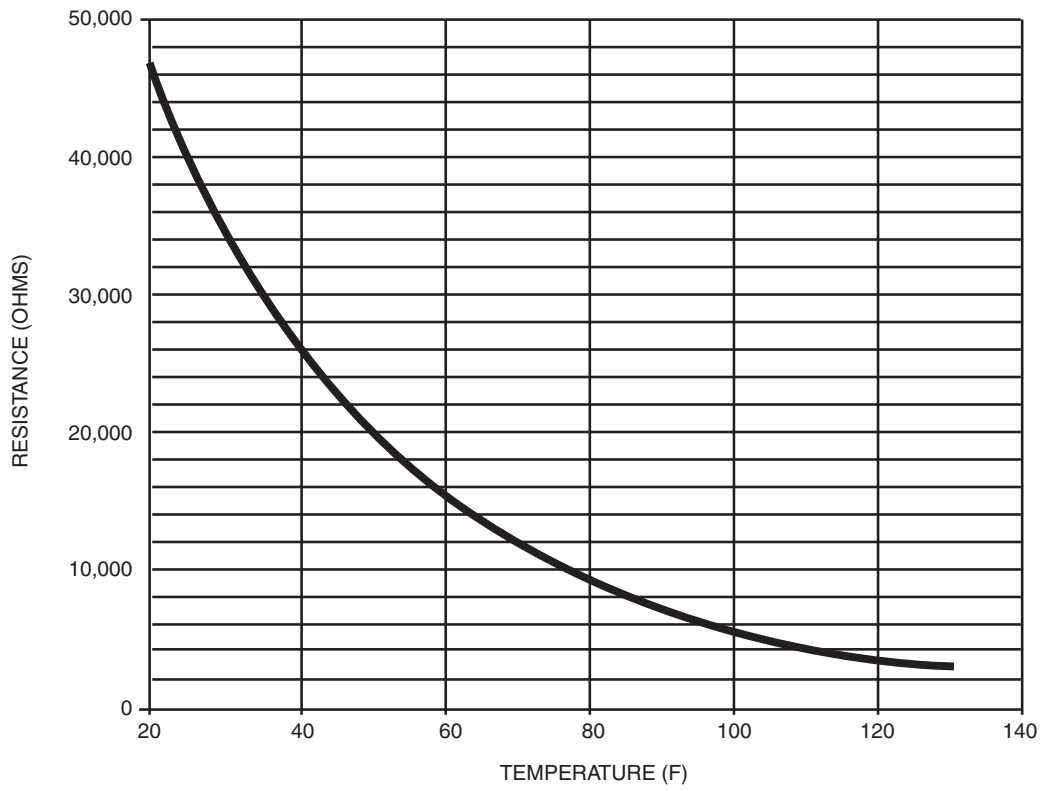

Thermistor Resistance vs Temperature

Fig. 6 - Thermistor Resistance vs. Temperature Chart

C00104

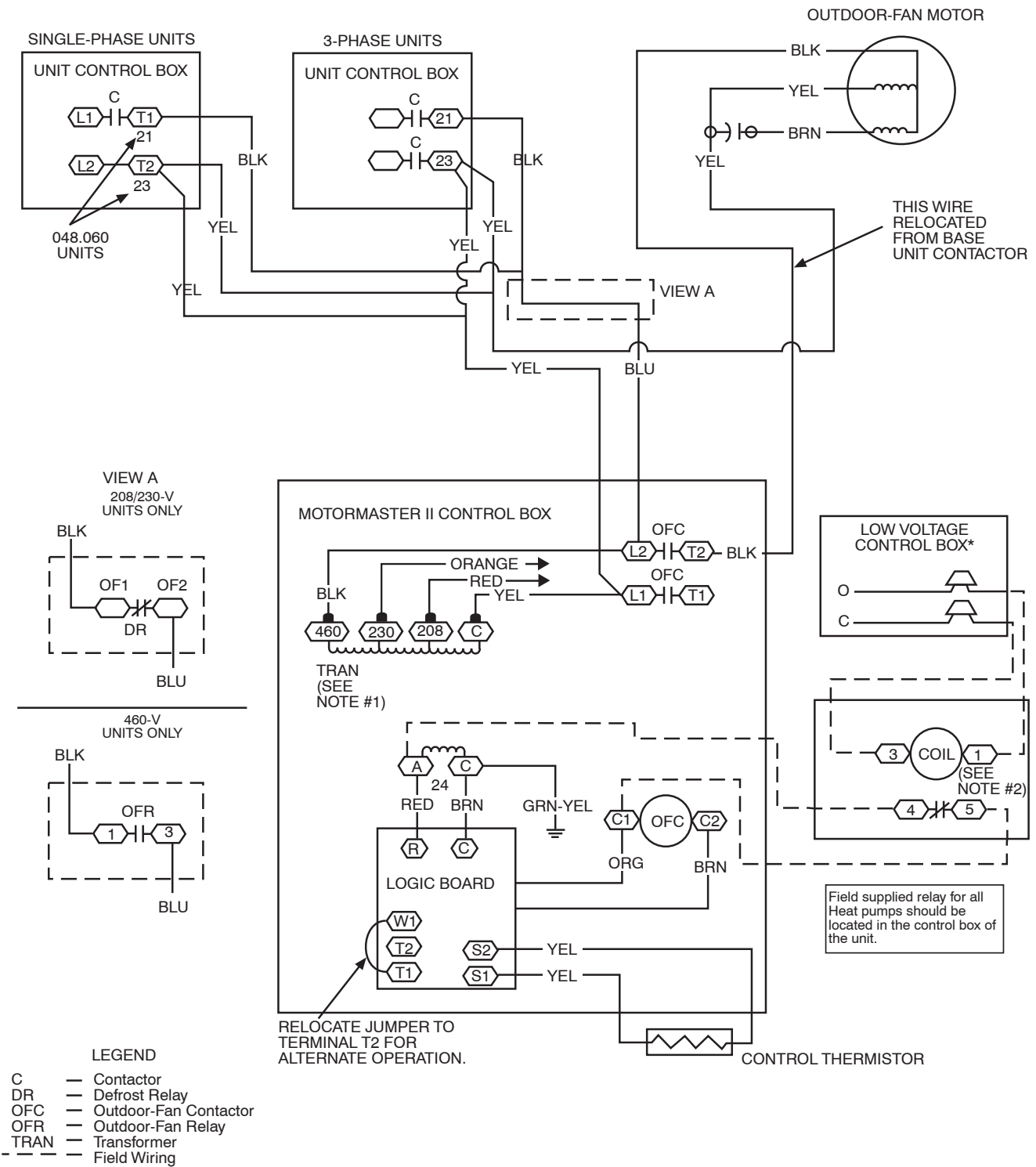

Fig. 7 - Wiring Schematic Heat Pumps

C00106

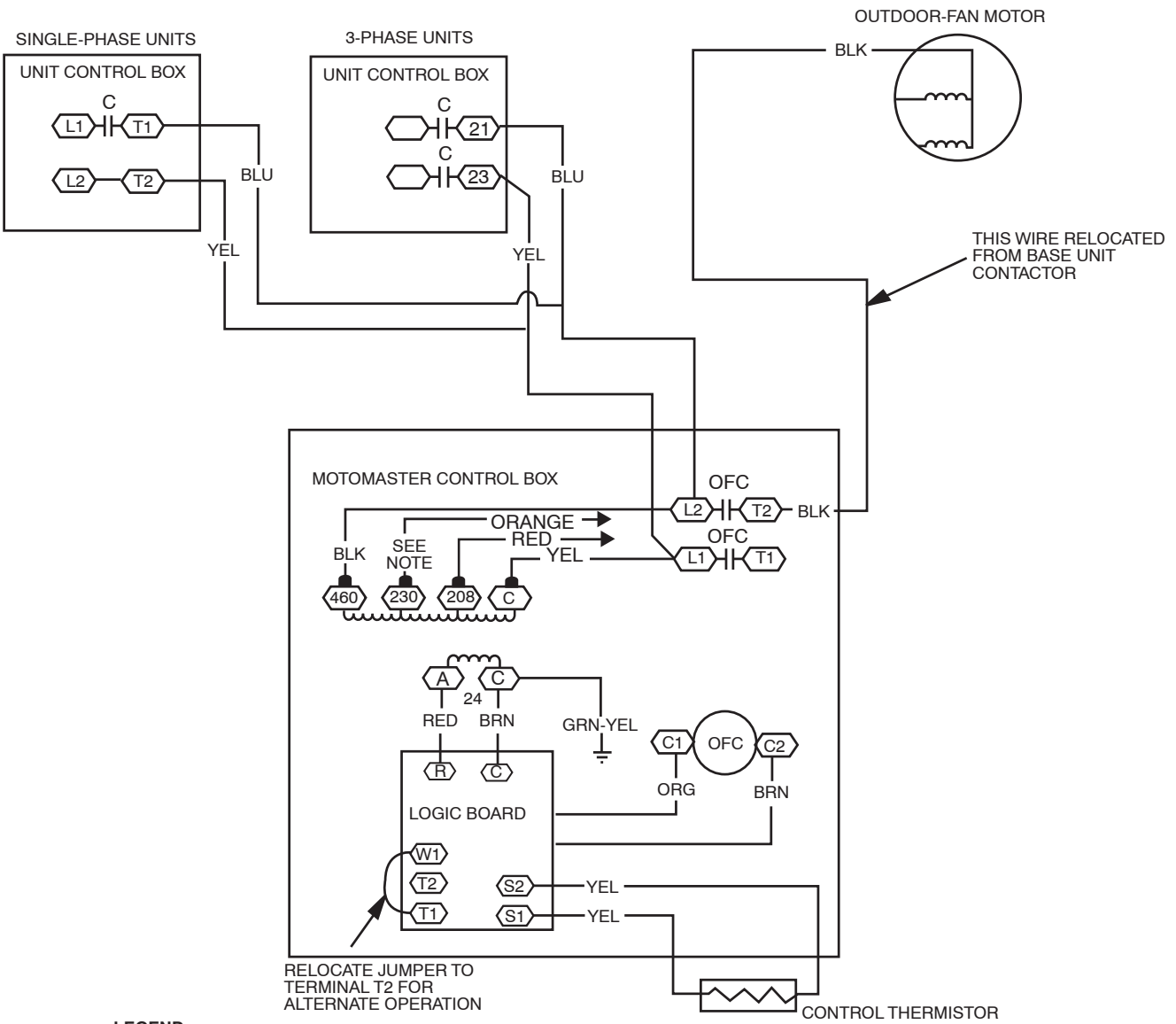

Fig. 8 - Wiring Schematic, AC and Gas PACs

C00140

MOUNTING TEMPLATE

CPLOWAMB

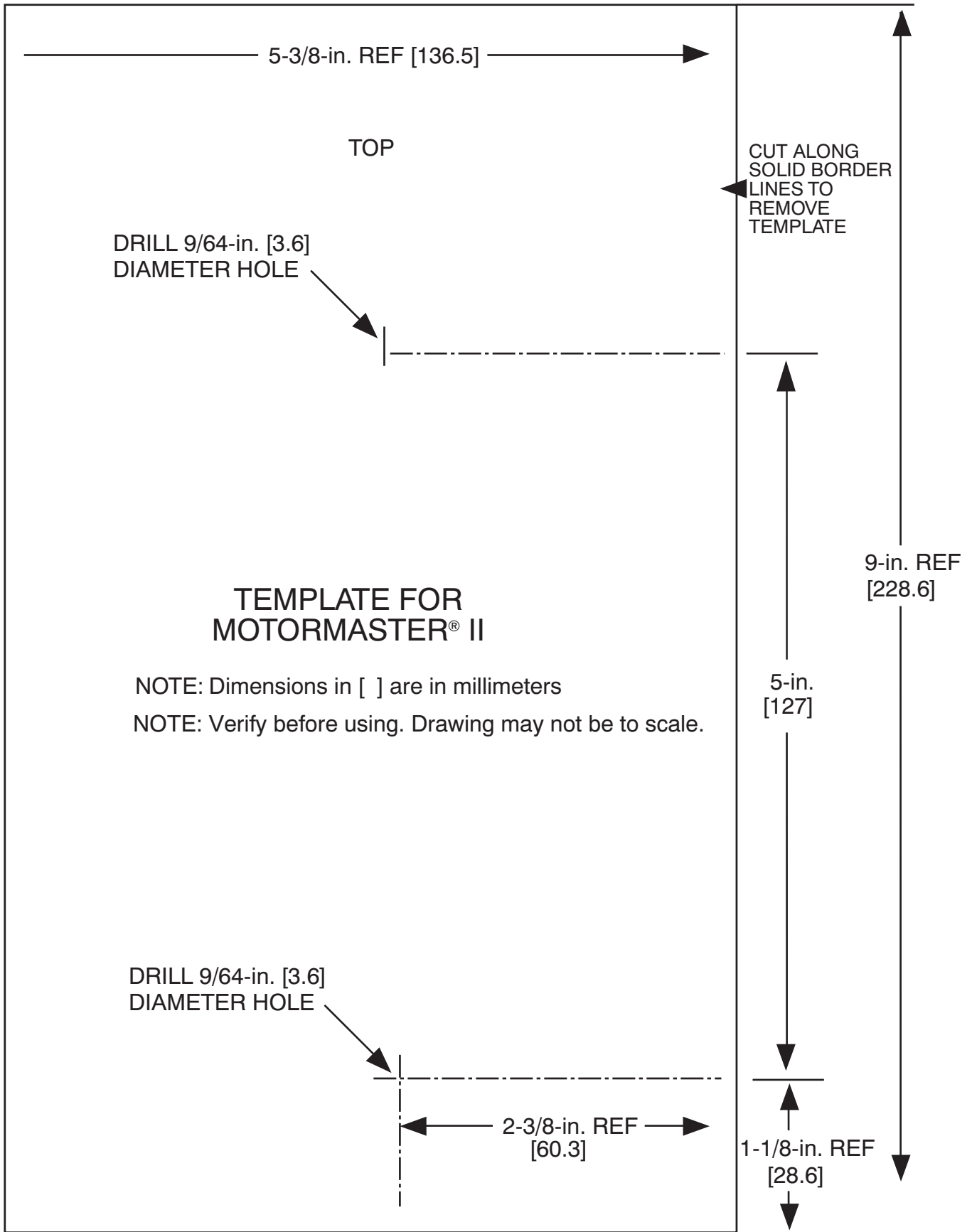

Fig. 9 - Controller Mounting Template

A11576

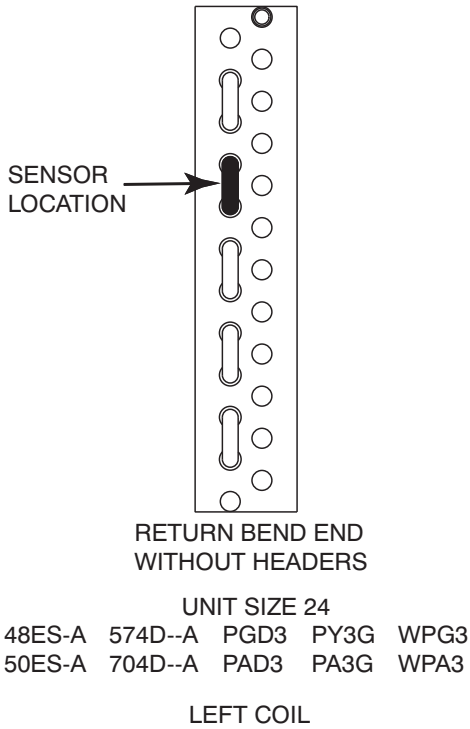

Fig. 10 - Sensor Mounting Location

A11057

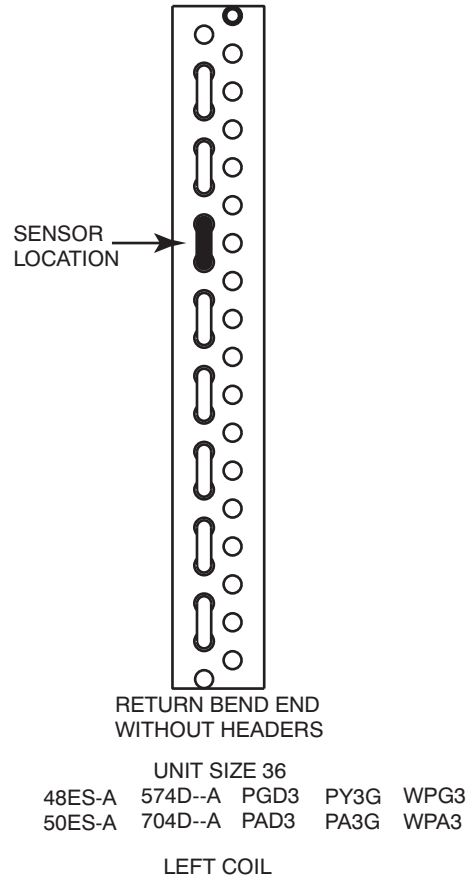

Fig. 12 - Sensor Mounting Location

A11059

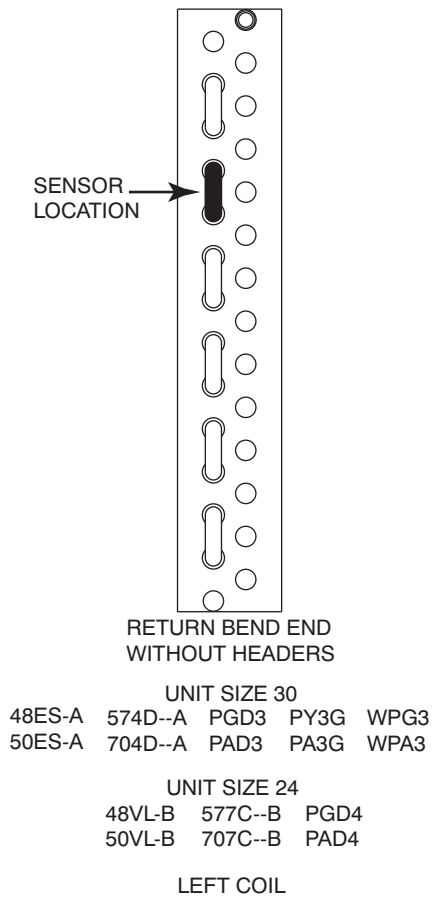

Fig. 11 - Sensor Mounting Location

A11058B

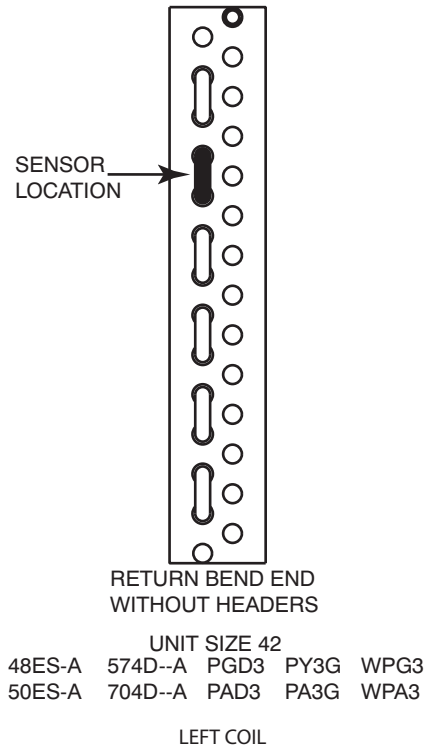

Fig. 13 - Sensor Mounting Location

A11061

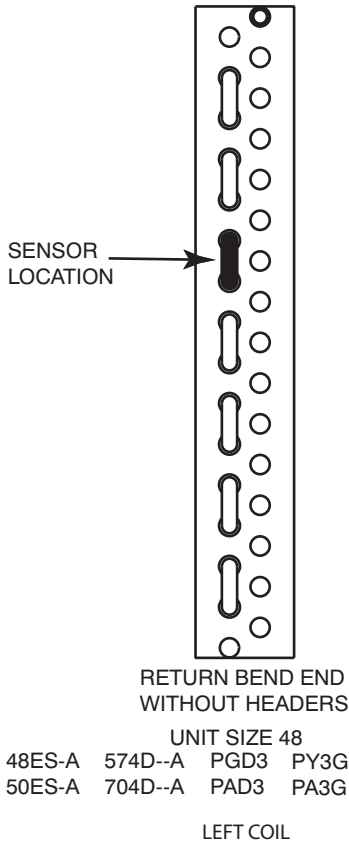

Fig. 14 - Sensor Mounting Location

A11062

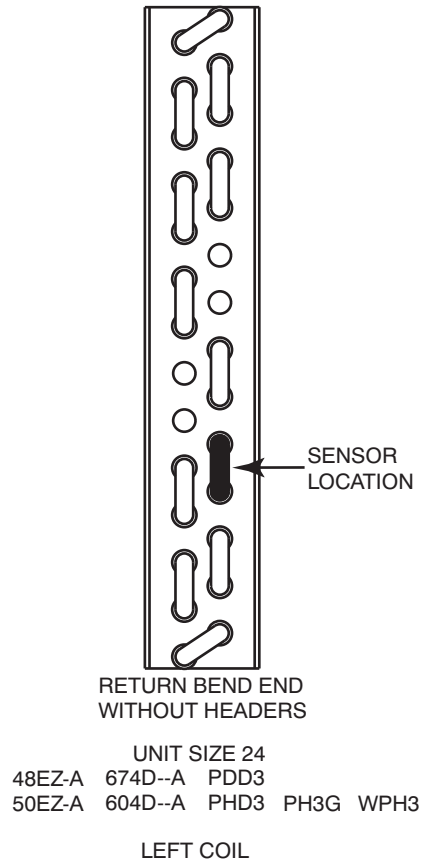

Fig. 16 - Sensor Mounting Location

A11063

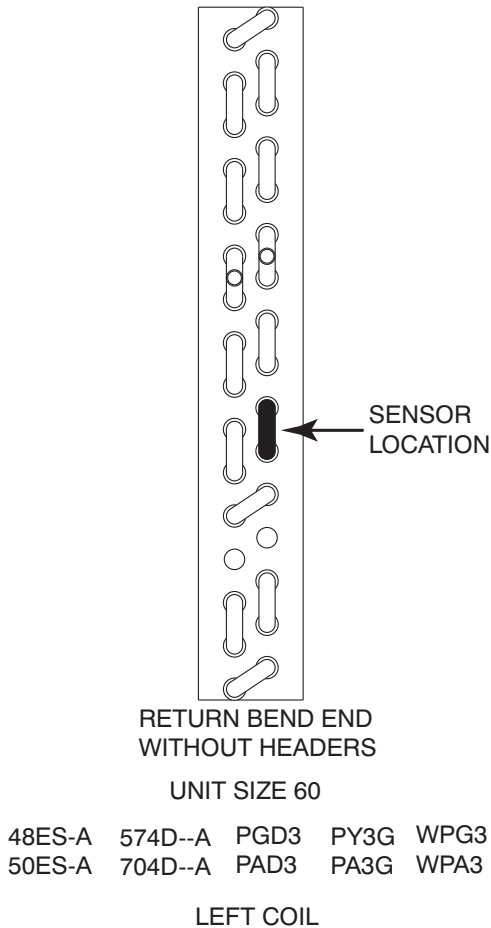

Fig. 15 - Sensor Mounting Location

A11060

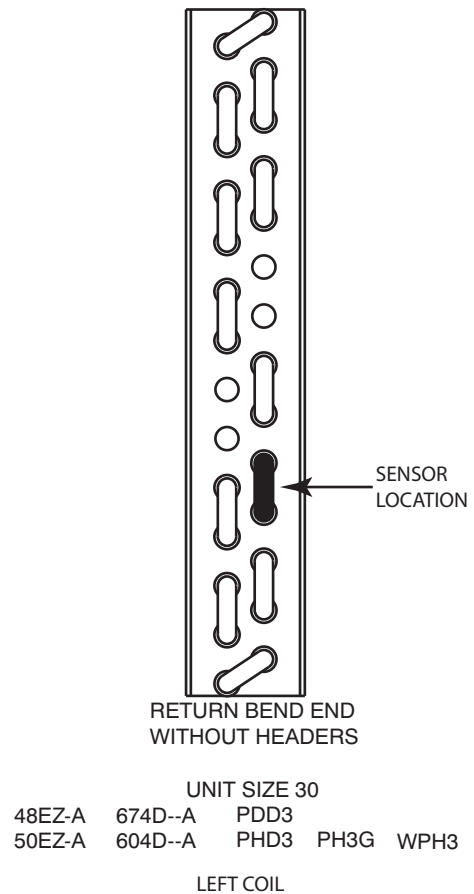

Fig. 17 - Sensor Mounting Location

A11064

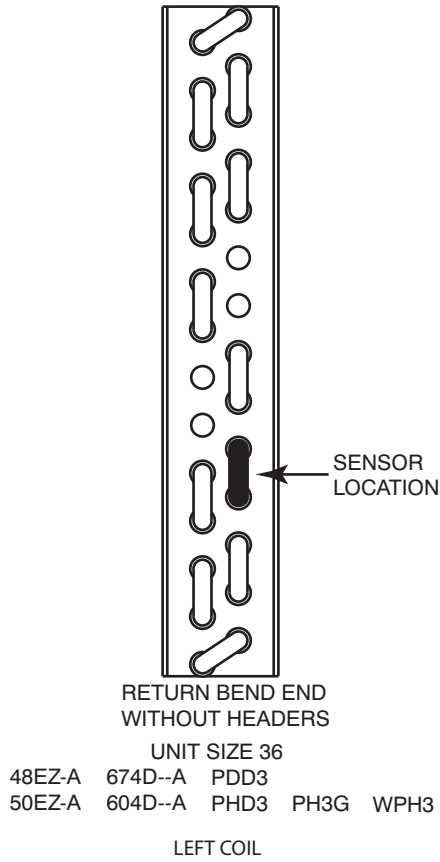

Fig. 18 - Sensor Mounting Location

A11065

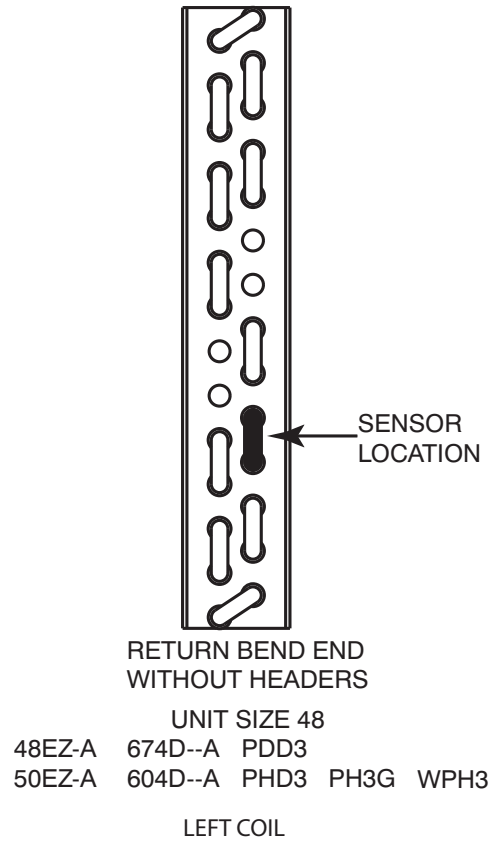

Fig. 20 - Sensor Mounting Location

A11067

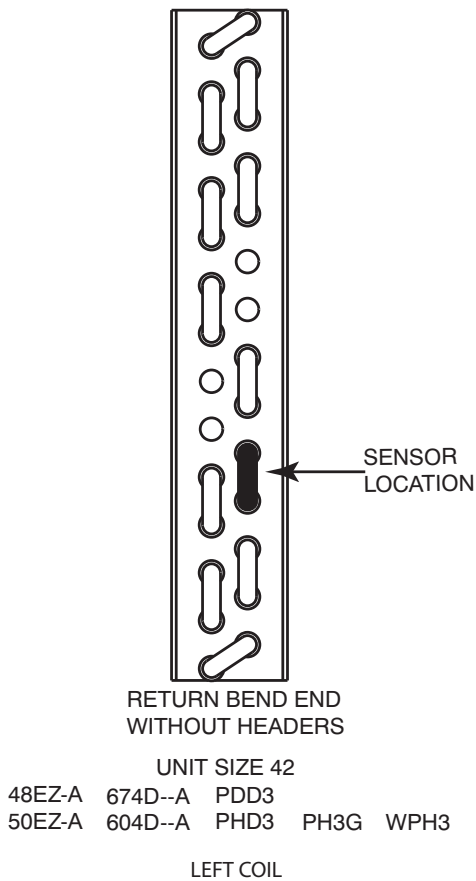

Fig. 19 - Sensor Mounting Location

A11066

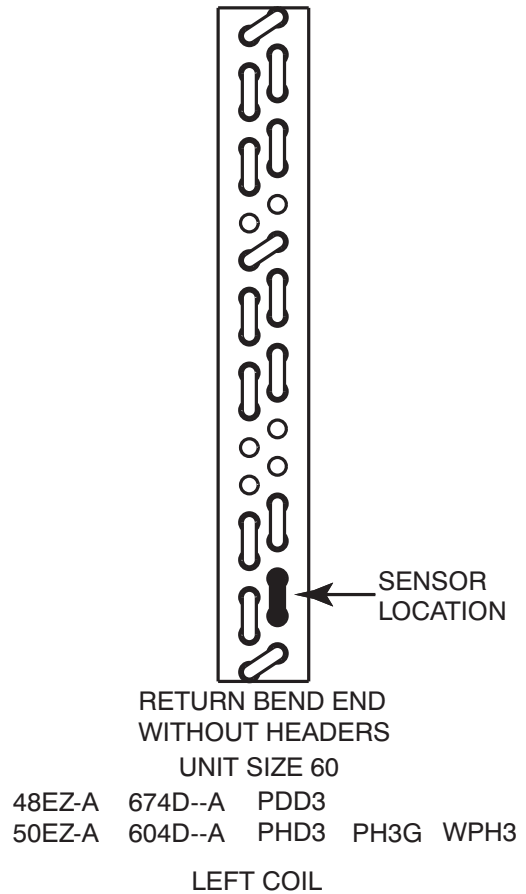

Fig. 21 - Sensor Mounting Location

A11068

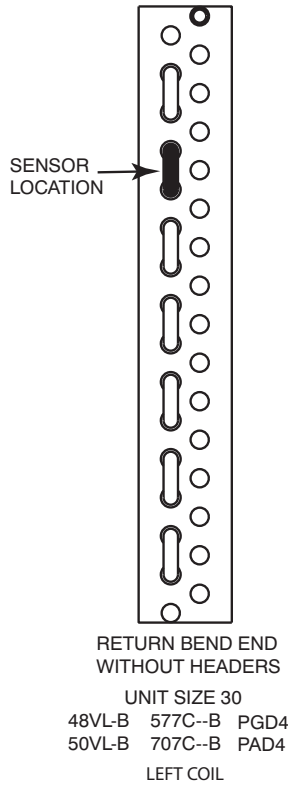

Fig. 22 - Sensor Mounting Location

A11069B

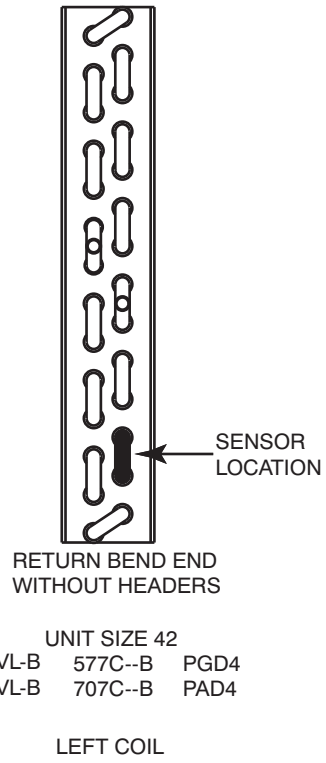

Fig. 24 - Sensor Mounting Location

A11071B

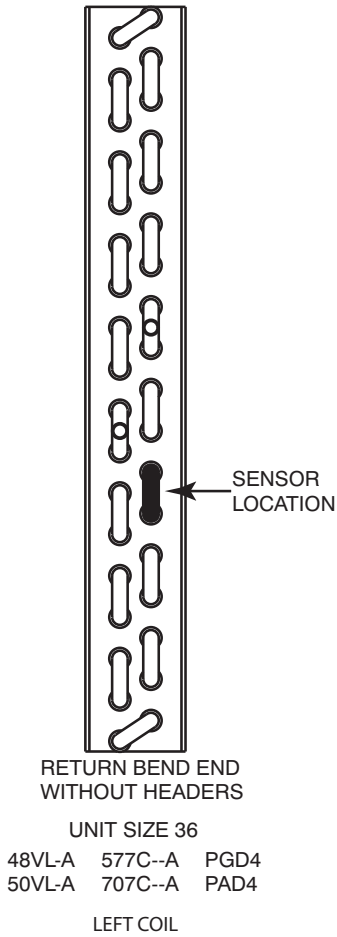

Fig. 23 - Sensor Mounting Location

A11070

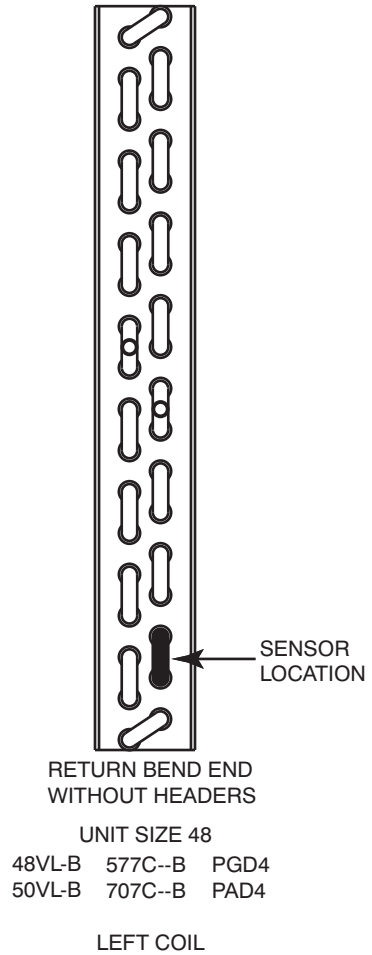

Fig. 25 - Sensor Mounting Location

A11072B

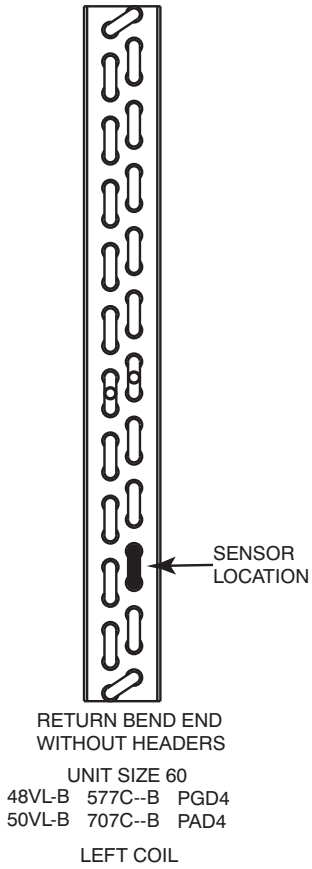

Fig. 26 - Sensor Mounting Location

A11073B

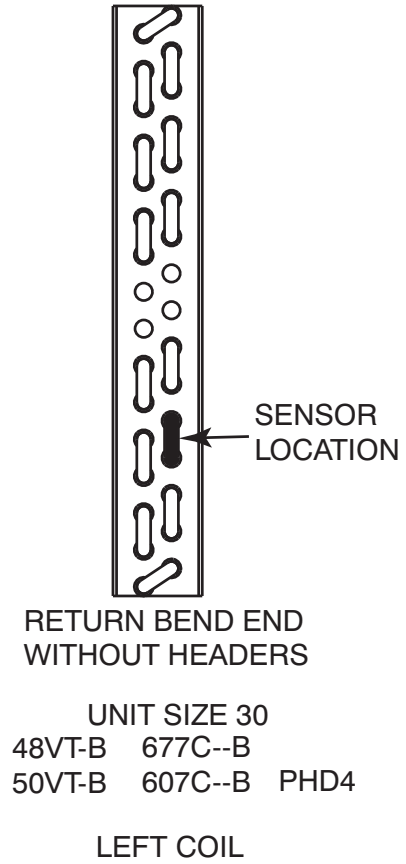

Fig. 28 - Sensor Mounting Location

A11075B

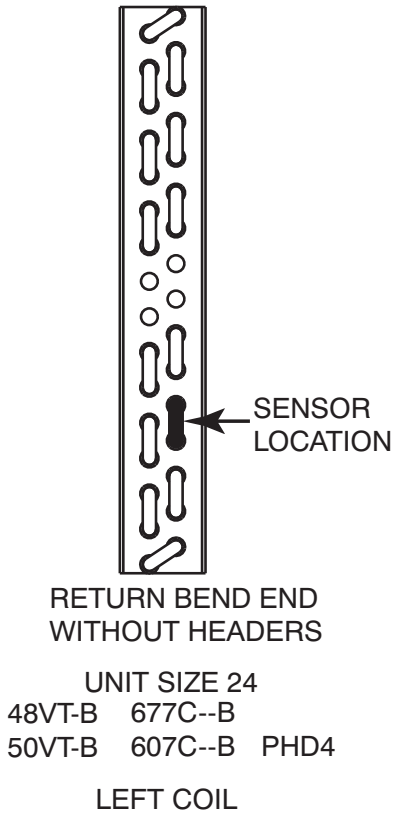

Fig. 27 - Sensor Mounting Location

A11074B

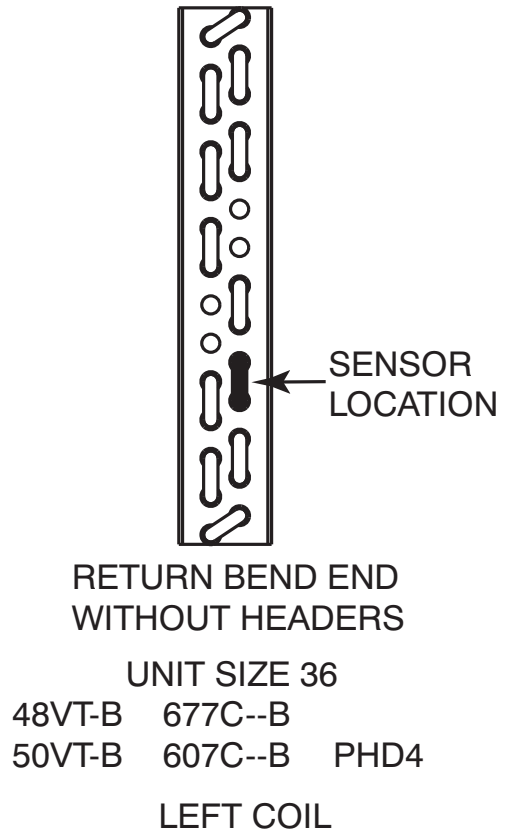
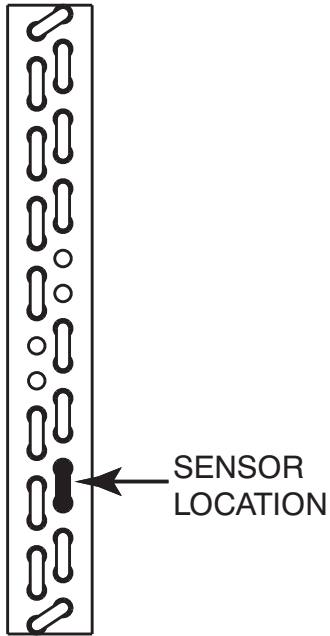

Fig. 29 - Sensor Mounting Location

A11076B



RETURN BEND END
WITHOUT HEADERS

UNIT SIZE 42
48VT-B 677C--B
50VT-B 607C--B PHD4

LEFT COIL

Fig. 30 - Sensor Mounting Location

A11077B

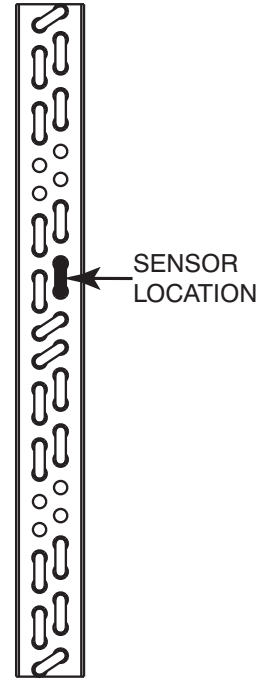

RETURN BEND END
WITHOUT HEADERS

UNIT SIZE 60
48VT-B 677C--B
50VT-B 607C--B PHD4

LEFT COIL

Fig. 32 - Sensor Mounting Location

A11079B

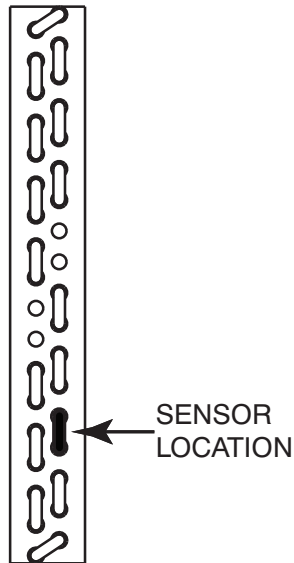

RETURN BEND END
WITHOUT HEADERS

UNIT SIZE 48
48VT-B 677C--B
50VT-B 607C--B PHD4

LEFT COIL

Fig. 31 - Sensor Mounting Location

A11078B

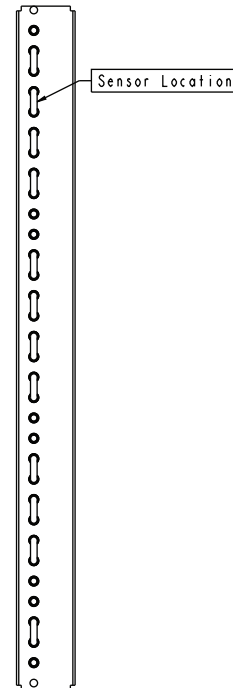

RETURN BEND END
WITHOUT HEADERS
UNIT SIZE 24 & 30
50ZP-C PA4Z PAJ4 WJA4

Fig. 33 - Sensor Mounting Location

A150734

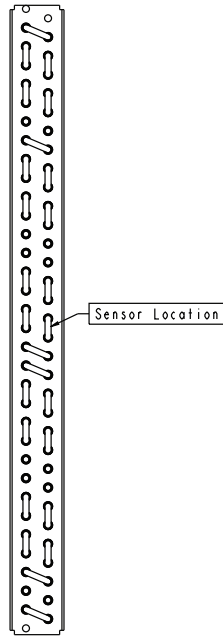

RETURN BEND END
WITHOUT HEADERS
UNIT SIZE 36
50ZP-C PA4Z PAJ4 WJA4

Fig. 34 - Sensor Mounting Location

A150735

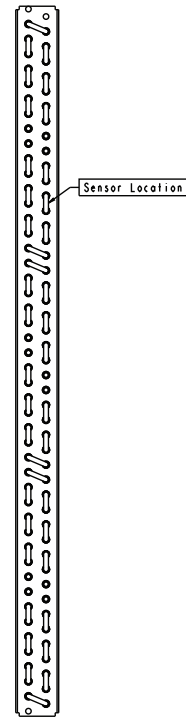

RETURN BEND END
WITHOUT HEADERS
UNIT SIZE 48
50ZP-C PA4Z PAJ4 WJA4

Fig. 36 - Sensor Mounting Location

A150737

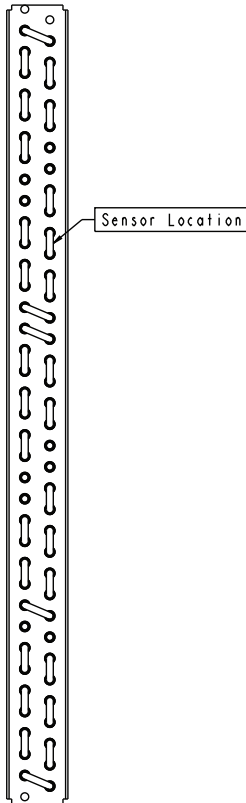

RETURN BEND END
WITHOUT HEADERS
UNIT SIZE 42
50ZP-C PA4Z PAJ4 WJA4

Fig. 35 - Sensor Mounting Location

A150736

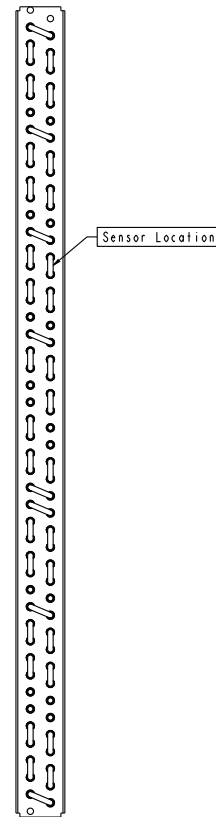

RETURN BEND END
WITHOUT HEADERS
UNIT SIZE 60
50ZP-C PA4Z PAJ4 WJA4

Fig. 37 - Sensor Mounting Location

A150738

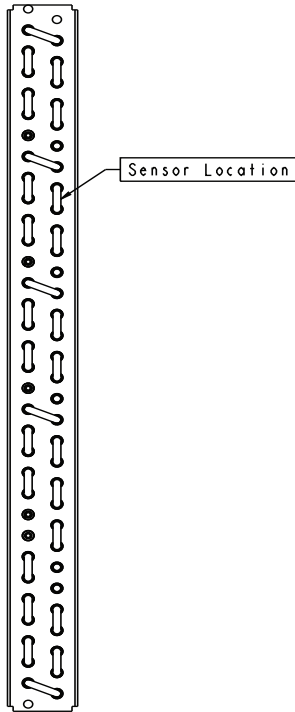

RETURN BEND END
WITHOUT HEADERS
UNIT SIZE 24
50ZH-C PH4Z PHJ4 WJH4

Fig. 38 - Sensor Mounting Location

A150739

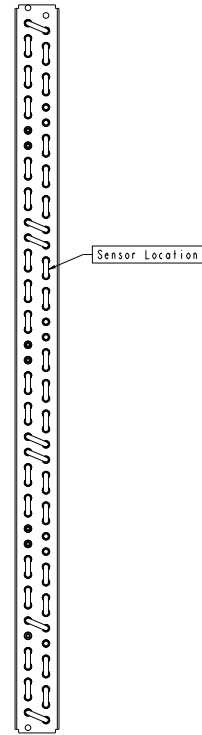

RETURN BEND END
WITHOUT HEADERS
UNIT SIZE 42
50ZH-C PH4Z PHJ4 WJH4

Fig. 40 - Sensor Mounting Location

A150741

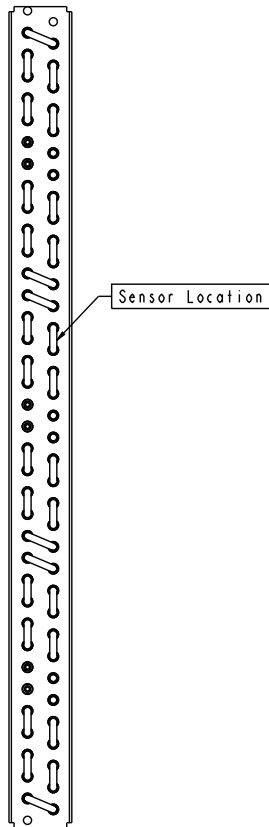

RETURN BEND END
WITHOUT HEADERS
UNIT SIZE 30 & 36
50ZH-C PH4Z PHJ4 WJH4

Fig. 39 - Sensor Mounting Location

A150740

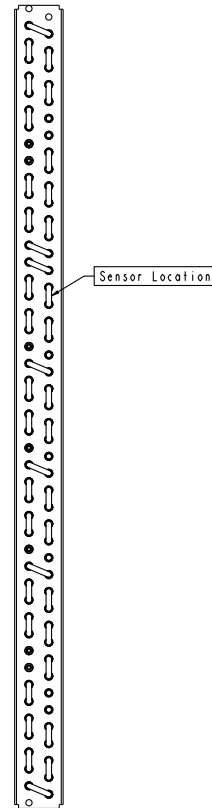

RETURN BEND END
WITHOUT HEADERS
UNIT SIZE 48
50ZH-C PH4Z PHJ4 WJH4

Fig. 41 - Sensor Mounting Location

A150742

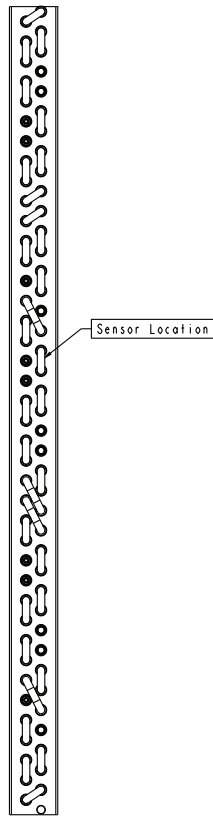

RETURN BEND END
WITHOUT HEADERS

UNIT SIZE 60
50ZH-C PH4Z PHJ4 WJH4

Fig. 42 - Sensor Mounting Location

A150743

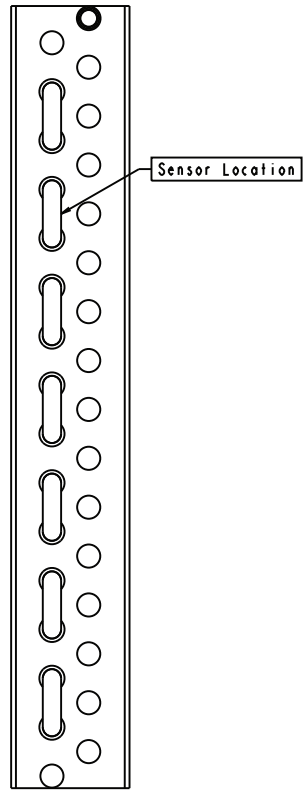

RETURN BEND END
WITHOUT HEADERS

UNIT SIZE 30
48VL-C 577C--C PY4G
PGD4/S4 WPG4

Fig. 44 - Sensor Mounting Location

A150745

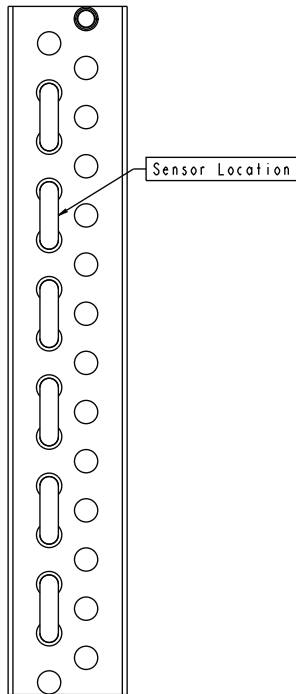

RETURN BEND END
WITHOUT HEADERS

UNIT SIZE 24
48VL-C 577C--C PY4G
PGD4/S4 WPG4

Fig. 43 - Sensor Mounting Location

A150744

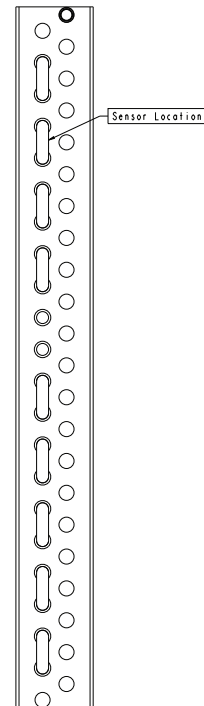

RETURN BEND END
WITHOUT HEADERS

UNIT SIZE 36
48VL-C 577C--C PY4G
PGD4/S4 WPG4

Fig. 45 - Sensor Mounting Location

A150746

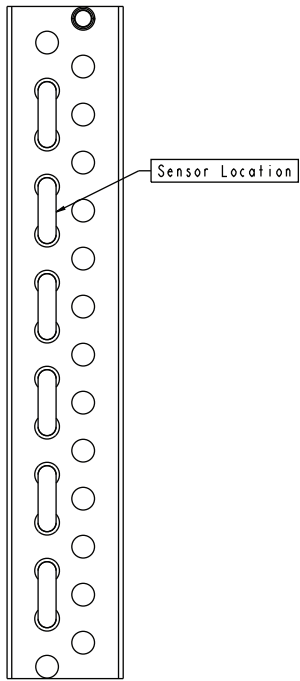

RETURN BEND END
WITHOUT HEADERS

UNIT 42
48VL-C 577C--C PY4G
PGD4/S4 WPG4
50VL-C 707C--C PA4G
PAD4 WPA4

Fig. 46 - Sensor Mounting Location

A150747

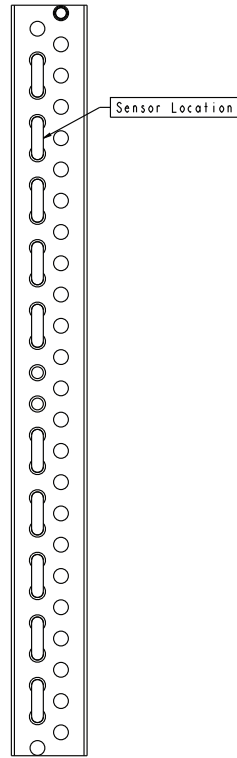

RETURN BEND END
WITHOUT HEADERS

UNIT SIZE 60
48VL-C 577C--C PY4G
PGD4/S4 WPG4
50VL-C 707C--C PA4G
PAD4 WPA4

Fig. 48 - Sensor Mounting Location

A150749

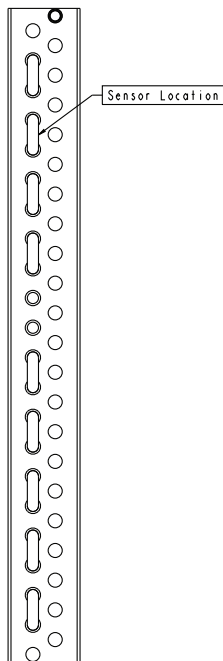

RETURN BEND END
WITHOUT HEADERS

UNIT SIZE 48
48VL-C 577C--C PY4G
PGD4/S4 WPG4
50VL-C 707C--C PA4G
PAD4 WPA4

Fig. 47 - Sensor Mounting Location

A150748

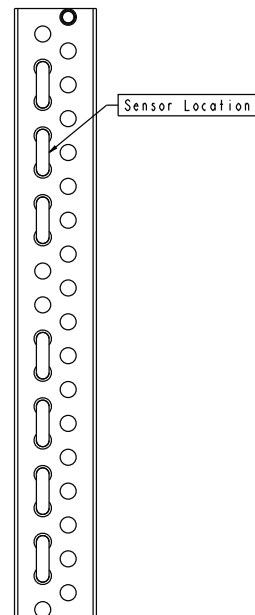

RETURN BEND END
WITHOUT HEADERS

UNIT SIZE 24
48VT-C 677C--C
PDD4/S4
50VT-C 607C--C
PHD4

Fig. 49 - Sensor Mounting Location

A150750

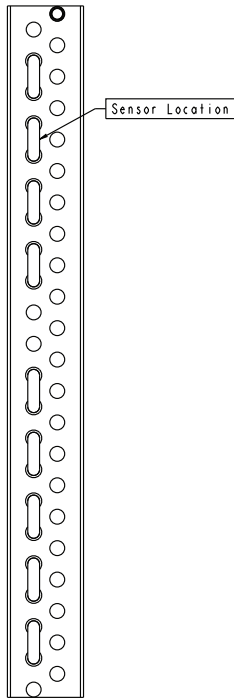

RETURN BEND END
WITHOUT HEADERS

UNIT SIZE 30
48VT-C 677C--C
PDD4/S4
50VT-C 607C--C PH4G
PHD4

Fig. 50 - Sensor Mounting Location

A150751

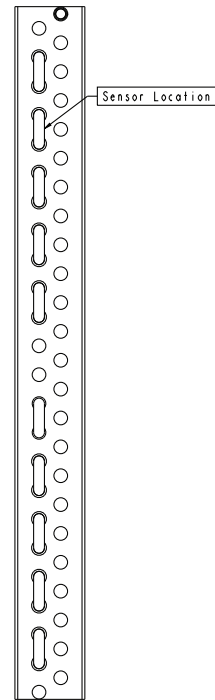

RETURN BEND END
WITHOUT HEADERS

UNIT SIZE 42 & 48
48VT-C 677C--C
PDD4/S4 WPG4
50VT-C 607C--C PH4G
PHD4

Fig. 52 - Sensor Mounting Location

A150753

CPLOWAMB

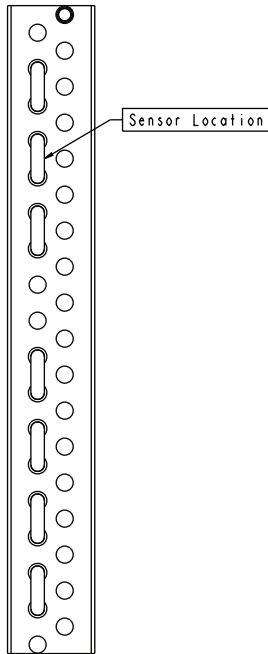

RETURN BEND END
WITHOUT HEADERS

UNIT SIZE 36
48VT-C 677C--C
PDD4/S4
50VT-C 607C--C PH4G
PHD4

Fig. 51 - Sensor Mounting Location

A150752

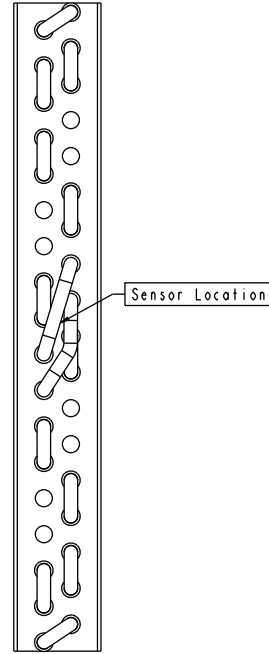

RETURN BEND END
WITHOUT HEADERS

UNIT SIZE 60
48VT-C 677C--C
PDD4/S4 WPG4
50VT-C 607C--C PH4G
PHD4

Fig. 53 - Sensor Mounting Location

A150754

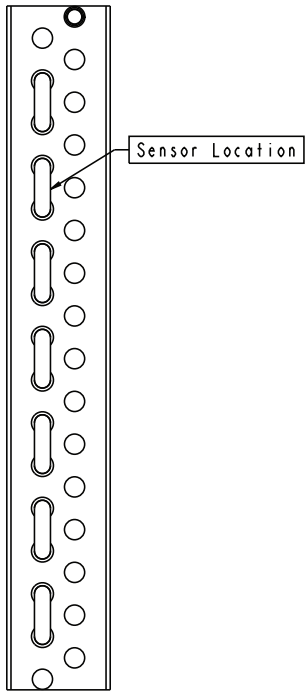

RETURN BEND END
WITHOUT HEADERS
UNIT SIZE 24
48VG-B 577E--B
PGR5
50VG 707E PAR5

Fig. 54 - Sensor Mounting Location

A150755

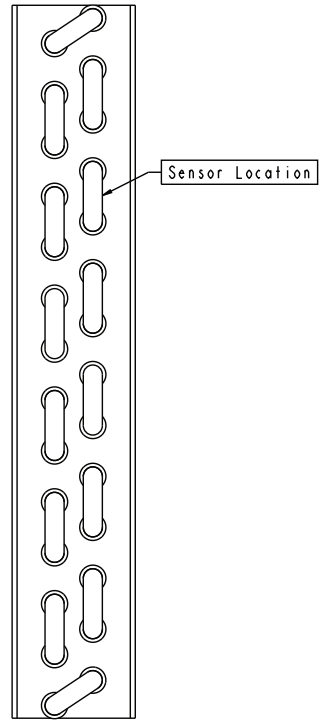

RETURN BEND END
WITHOUT HEADERS

UNIT SIZE 36 & 42
48VG-B 577E--B PGR5
50VG 707E PAR5

Fig. 56 - Sensor Mounting Location

A150761

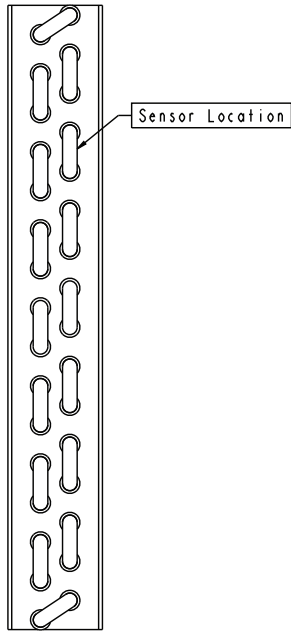

RETURN BEND END
WITHOUT HEADERS

UNIT SIZE 30
48VG-B 577E--B
PGR5
50VG 707E PAR5

Fig. 55 - Sensor Mounting Location

A150756

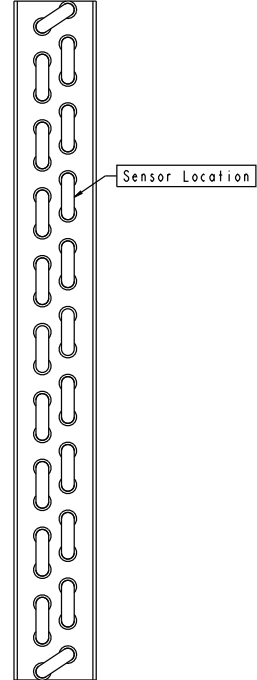

RETURN BEND END
WITHOUT HEADERS

UNIT SIZE 48
48VG-B 577E--B PGR5
50VG 707E PAR5

Fig. 57 - Sensor Mounting Location

A150762

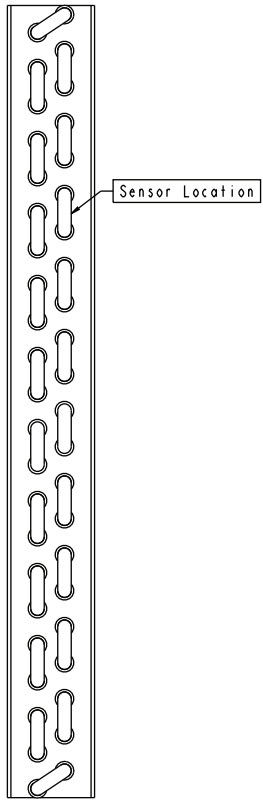

RETURN BEND END
WITHOUT HEADERS

UNIT SIZE 60
48VG-B 577E--B PGR5
50VG 707E PAR5

Fig. 58 - Sensor Mounting Location

A150763

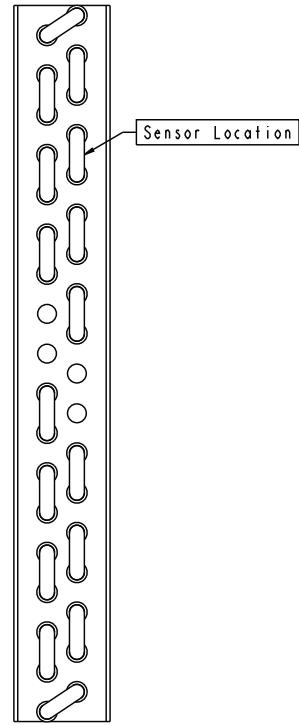

RETURN BEND END
WITHOUT HEADERS

UNIT SIZE 30
48VR-B 677E--B
50VR 607E PHR5

Fig. 60 - Sensor Mounting Location

A150765

CPLOWAMB

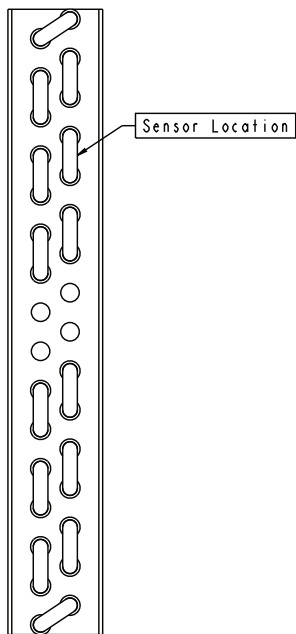

RETURN BEND END
WITHOUT HEADERS

UNIT SIZE 24
48VR-B 677E--B
50VR 607E PHR5

Fig. 59 - Sensor Mounting Location

A150764

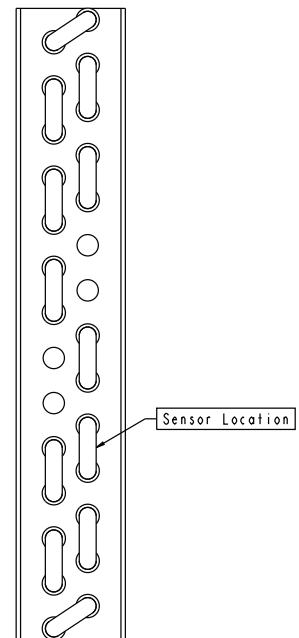

RETURN BEND END
WITHOUT HEADERS

UNIT SIZE 36
48VR-B 677E--B PGR5
50VR 607E PHR5

Fig. 61 - Sensor Mounting Location

A150757

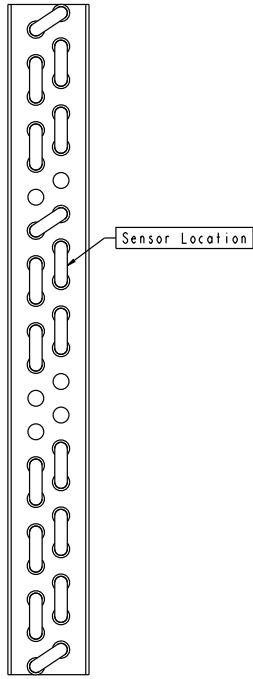

RETURN BEND END
WITHOUT HEADERS

UNIT SIZE 42
48VR-B 677E--B PGR5
50VR 607E PHR5

Fig. 62 - Sensor Mounting Location

A150758

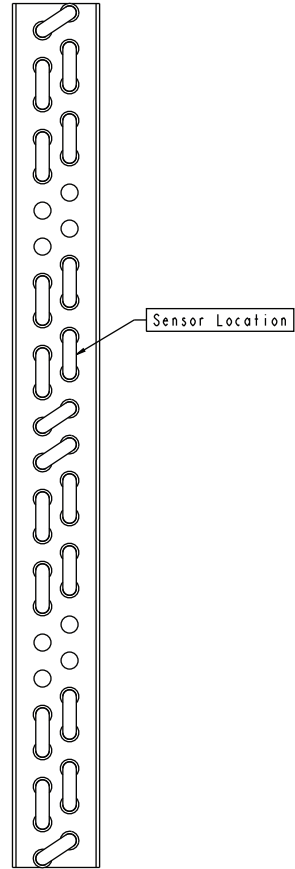

RETURN BEND END
WITHOUT HEADERS

UNIT SIZE 60
48VR-B 677E--B PGR5
50VR 607E PHR5

Fig. 64 - Sensor Mounting Location

A150760

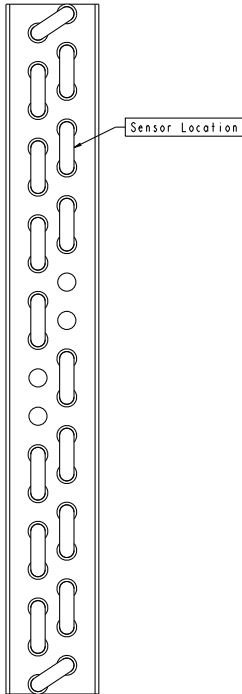

RETURN BEND END
WITHOUT HEADERS

UNIT SIZE 48
48VR-B 677E--B PGR5
50VR 607E PHR5

Fig. 63 - Sensor Mounting Location

A150759