

# Installation Instructions

Cycle Protector

KSACY0101AAA

**NOTE:** Read the entire instruction before starting the installation.

## INTRODUCTION

This instruction covers installation of the Cycle Protector, KSACY0101AAA, on split-system air conditioners and heat pumps.

The cycle protector is designed to prevent compressor short cycling. This control provides an approximate 5-minute delay after power to the compressor has been interrupted for any reason, including power outage, protector control trip, thermostat jiggling, or normal cycling.

The following items are included in the kit:

Cycle protector	1
Screw	1
Black wire	1
Violet wire (air conditioners)	1
Wire label (air conditioners)	1
Yellow wire (heat pumps)	1
Wire label (heat pumps)	2

## SAFETY CONSIDERATIONS

Installing and servicing air conditioning equipment can be hazardous due to system pressures and electrical components. Only trained personnel should install or service air conditioning equipment.

Untrained personnel can perform basic maintenance functions such as cleaning coils or cleaning and replacing filters. All other operations should be performed by trained service personnel. When working on air conditioning equipment, observe precautions in the literature and on tags and labels attached to the unit.

Follow all safety codes. Wear safety glasses and work gloves.

---

**⚠ WARNING:** Before beginning any installation or modification be sure the main electrical disconnect switch is in the OFF position. TAG DISCONNECT SWITCH WITH A SUITABLE WARNING LABEL. Electrical shock can cause personal injury or death.

---

## INSTALLATION

### PROCEDURE 1—AIR CONDITIONING APPLICATIONS

Proceed as follows to install the Cycle Protector control and to make the electrical connections.

1. Remove mounting screw in control box below contactor and use to assemble Cycle Protector in control box.
2. Install Cycle Protector in control box using screw provided in kit and screw removed from control box.
3. Locate contactor, determine two contactor coil terminals, and disconnect lead that is Y leg of 24-volt circuit (lead may be routed through high- and/or low-pressure, and/or discharge-temperature switches, if used). Route this lead to Cycle Protector and connect to terminal T1.
4. Connect violet wire from kit to vacant contactor coil terminal, route wire to Cycle Protector, and connect to terminal T2.
5. Remove black wire from kit, connect to contactor other coil terminal, route other end to Cycle Protector, and connect to terminal T3.
6. Attach air conditioner wire label (provided in kit) next to unit wiring label.

### PROCEDURE 2—HEAT PUMP APPLICATIONS

Proceed as follows to install the Cycle Protector and to make the electrical connections.

**NOTE:** Refer to Fig. 2 (Fig. 3 if Service Alarm is used), the unit wiring label, and the label provided with kit when making electrical connections. Unit may or may not be equipped with protective controls shown on wiring diagrams.

1. Install Cycle Protector in control box using screw provided in kit.
2. Disconnect lead that is connected to Y at defrost board. Route this lead to Cycle Protector and connect to terminal T2.

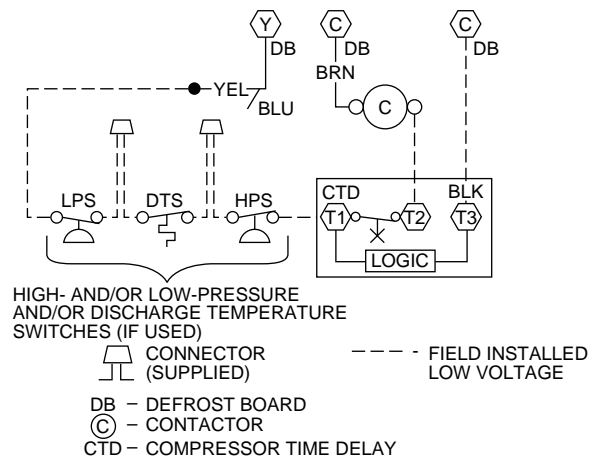
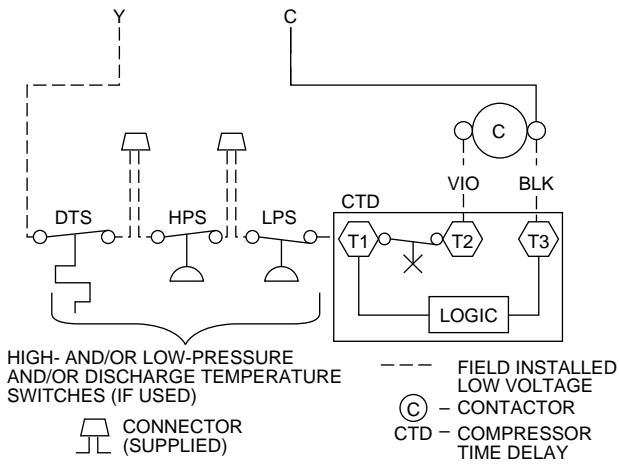

A91028

A91029

**Fig. 1—Field 24-volt Connections for Air Conditioning**

**Fig. 2—Field 24-volt Connections for Heat Pumps**

3. Remove black wire from kit, connect to defrost board terminal C, route other end to Cycle Protector and connect to terminal T3.
4. Connect yellow wire from kit to Y on defrost board, route wire to Cycle Protector, and connect to terminal T1.
5. Attach heat pump wiring label (provided with kit) next to unit wiring label.

**PROCEDURE 3—SYSTEM START-UP**

After all electrical connections have been completed, proceed as follows to check system operation.

1. Check all electrical connections (both factory and field) to ensure they are properly completed and tight.
2. Restore power to unit and set room thermostat to start cooling cycle.
3. Observe that compressor, fan motor, and blower motor are running, and that unit is cooling conditioned space. Allow unit to continue operating and continue with next item.
4. With room thermostat "calling for cooling," interrupt electrical power to unit by moving thermostat switch to OFF position and then back to ON position.
5. Observe that compressor does not restart for approximately 5 minutes.
6. Replace all access doors. Unit is now ready for normal operation.

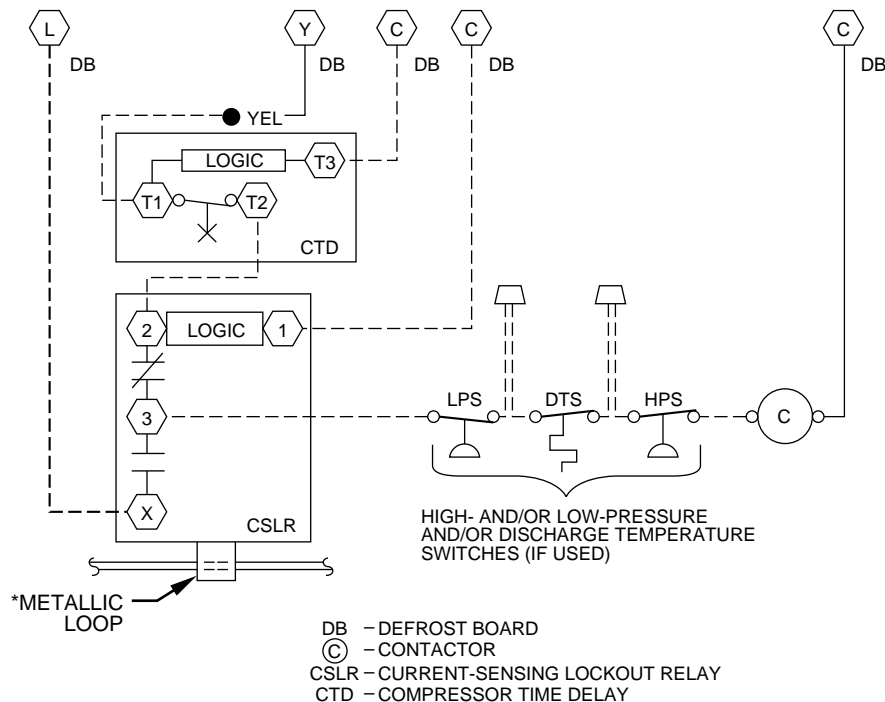

**Fig. 3—Field 24-volt Connections for Heat Pumps with Service Alarm**

A91030