



# MicroMetl

## Actuator Product Data Sheet



Foremost HVAC Accessory Manufacturer



# MicroMetl

## Table of Contents

---

Topic	Page Number
General Install Instructions	1

# M7215 Damper Motors

**PRODUCT DATA**

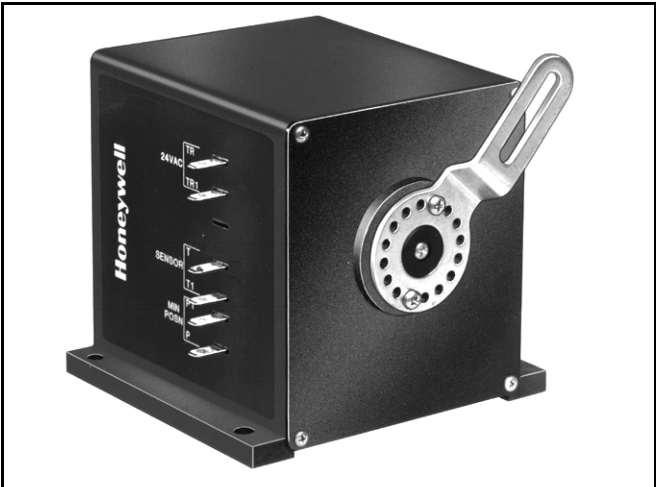

## FEATURES

- M7215 Damper Motors provide modulating control of economizer dampers from a 2-10 Vdc controller.
- Quiet, high efficiency drive motor.
- High impact, glass-fiber reinforced plastic case is rugged, lightweight and corrosion resistant.
- Provides 2-10 Vdc output signal proportional to the shaft position.

## APPLICATION

M7215 Damper Motors provide 25 lb-in. torque with spring return and 2-10 Vdc modulating control of economizer systems, ventilation dampers and combustion air dampers used in residential or commercial HVAC equipment.

### Contents

Application .....	1
Features .....	1
Specifications .....	2
Ordering Information .....	2
Installation .....	3
Operation and Checkout .....	4



## SPECIFICATIONS

**Models:** ML7215: 25 lb-in. (2.8 N•m) torque, foot-mounted spring-return damper motor with 2-10 Vdc feedback signal. Accepts 2-10 Vdc control signal.

**Dimensions:** See Fig. 1.

**Electrical Ratings:**

Supply Voltage: 24 ±6 Vac 50/60 Hz.  
 Power Consumption:  
 24 Vac, 60 Hz: 8.7 VA.  
 24 Vac, 50 Hz: 8.4 VA.

**Torque:**

Lift and Hold: 25 lb-in. (2.8 N•m).  
 Spring Return: 25 lb-in. (2.8 N•m).  
 Breakaway: 40 lb-in (4.5 N•m).

**IMPORTANT**

*Never use motor continuously at the breakaway torque rating.*

**NOTE:** NOTE: Breakaway torque available to overcome occasional large loads such as a seized damper.

**Stroke:**

Travel: 90°.  
 Timing:  
 Driving: 86 ±5 seconds.  
 Spring Return: 13 ±5 seconds.

**Motor Rotation (Viewed From Shaft End):**

Closed Position: Limit of clockwise rotation.  
 Open Position: Limit of counterclockwise rotation.  
 Crank Arm Rotation Limits: See Fig. 2.  
 Shipped with shaft in closed position.

**Ambient Ratings:**

Temperature:  
 Operating: -25°F to +125°F (-32°C to +52°C).  
 Storage: -30°F to +150°F (-34°C to +66°C).  
 Humidity: 5 to 95 percent relative humidity, noncondensing.

**Terminal Connections:** 1/4 in. (6 mm) quick-connect terminals mounted on motor.

**Shaft:** Single-ended drive shaft with crank arm supplied.

**Reliability:**

Full-Stroke Cycles: 60,000.  
 Repositions: 1,500,000.

**Approvals:**

Underwriters Laboratory Inc.:  
 Flammability Rating: UL94-5V.  
 Component Recognized: File No. E4436, Guide No. XAPX2, Vol. 9, Section 1, 7-25-83.

**Accessories:** See Table 1.

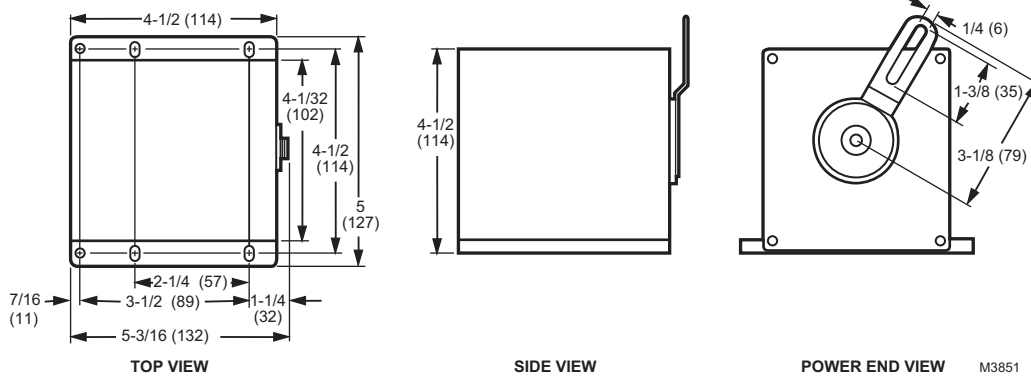

**Fig. 1. M7215 Damper Motor dimensions in in. (mm).**

## ORDERING INFORMATION

When purchasing replacement and modernization products from your TRADELINE® wholesaler or distributor, refer to the TRADELINE® Catalog or price sheets for complete ordering number.

If you have additional questions, need further information, or would like to comment on our products or services, please write or phone:

1. Your local Honeywell Automation and Control Products Sales Office (check white pages of your phone directory).
2. Honeywell Customer Care  
 1885 Douglas Drive North  
 Minneapolis, Minnesota 55422-4386

In Canada—Honeywell Limited/Honeywell Limitée, 35 Dynamic Drive, Toronto, Ontario M1V 4Z9.  
 International Sales and Service Offices in all principal cities of the world. Manufacturing in Australia, Canada, Finland, France, Germany, Japan, Mexico, Netherlands, Spain, Taiwan, United Kingdom, U.S.A.

**Table 1. M7215 Accessories.**

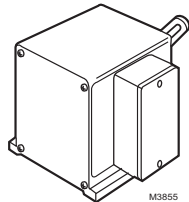
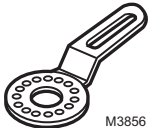
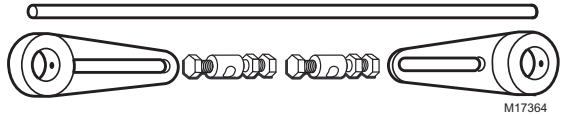
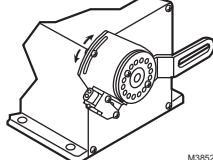
<p>7640QF Terminal Enclosure—provides wiring enclosure for electrical terminal connections. Enclosure can be used with or without 40784EHB Screw Terminal Adapter. Bag assembly includes: terminal housing, cover plate and mounting screws.</p>	 <p>M3855</p>
<p>4074EGR Crank Arm Assembly.</p>	 <p>M3856</p>
<p>Q298B Linkage Hardware—enables linking the motor to an additional damper. Consists of two crank arm assemblies, two ball joint assemblies, and variable length push rods (in 10, 16, or 24 inch lengths)</p>	 <p>M17364</p>
<p>4074EKV Auxiliary Switch—provides switching capability for controlling auxiliary equipment. The switch acts as a function of the motor shaft position.</p>	 <p>M3852</p>

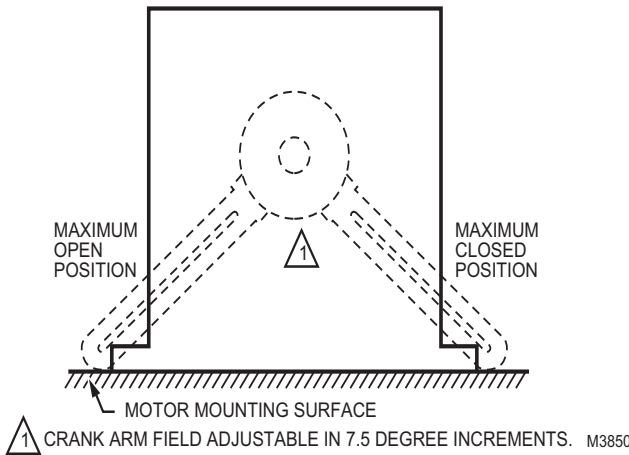

**Fig. 2. Limits of crank arm rotation.**

## INSTALLATION

### When Installing this Product...

1. Read instructions carefully. Failure to follow them could damage the product or cause a hazardous condition.
2. Check ratings and description given in the specifications to make sure the product is suitable for your application.
3. Installer must be a trained, experienced service technician.
4. After installation is complete, check out product operation as provided in these instructions.

**⚠ CAUTION**  
**Electrical Shock or Equipment Damage Hazard.**  
 Can shock individuals or short equipment circuitry.  
 Disconnect power supply before installation.

**⚠ CAUTION**  
**Personal Injury Hazard.**  
**Spring-return assembly can release.**  
 Leave end covers attached to the motor.

### Location and Mounting

Locate motor as close as possible to the equipment to be controlled. Refer to Fig. 1 for mounting dimensions.

1. Mount motor with the shaft horizontal to ensure maximum life.
- NOTE: NOTE: Operation in other positions is possible when required by the application.
2. Remove crank arm (secured with two screws) from the motor hub.

**IMPORTANT**  
*Position crank arm on hub so it does not strike motor mounting surface during any portion of full stroke. See Fig. 2.*

3. Reposition the crank arm to accommodate specific damper requirements.
- NOTE: NOTE: Crank arm position is adjustable in eight degree increments.
4. Reconnect crank arm to the motor hub.

5. If there is an excess length of linkage rod, cut it to size. Make necessary minor adjustments until desired operation is obtained.
6. Tighten all nuts and set screws.

4. If questions arise regarding this product, contact your distributor or local Honeywell representative.

## WIRING

### CAUTION

**Electrical Shock or Equipment Damage Hazard.**  
**Can shock individuals or short equipment circuitry.**  
 Disconnect power supply before installation.

All wiring must comply with applicable codes and ordinances. Refer to Fig. 3 and 4 for typical hookups.

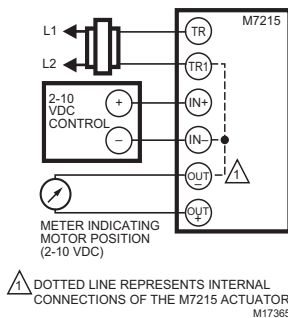

**Fig. 3. Typical M7215 wiring.**

## OPERATION AND CHECKOUT

The M7215 Damper Motor accepts input from a 2-10 Vdc controller. The motor can be checked out either directly or by using a controller.

### IMPORTANT

1. If necessary, release one of the previously tightened linkage connections to prevent damage.
2. Check for proper operation, making sure that the linkage does not bind and that the motor travels smoothly throughout its cycle from fully open to fully closed.

NOTE: NOTES: This motor checkout assures that:

1. The motor operates the load.
2. The motor responds properly to the controller.
3. There is no linkage binding or motor stalling at any point of travel.

### Automation and Control Solutions

Honeywell International Inc.  
 1985 Douglas Drive North  
 Golden Valley, MN 55422  
 customer.honeywell.com

Honeywell Limited-Honeywell Limitée  
 35 Dynamic Drive  
 Toronto, Ontario M1V 4Z9

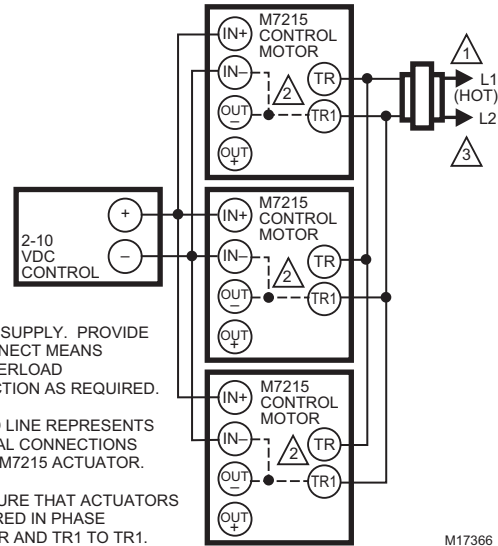

**Fig. 4. Three M7215 Damper Motors connected in parallel.**

## Direct Checkout

1. Mount the motor for the required application.
2. Check the damper position and make sure 24 Vac is present across TR and TR1.
3. Apply 10 Vdc to IN+ and IN- to move damper to the opposite position. The motor should drive the damper.
4. If the motor does not run, verify that the motor and crank arm are properly installed for either clockwise or counterclockwise rotation.
5. If installation is correct, but the motor does not run, replace the motor.

## Controller Checkout

1. Adjust controller setpoint to call for cooling. Observe the motor.
2. If the damper is closed, it should begin to open.
3. If the damper remains closed, move controller setpoint farther below room temperature.
4. If the damper still does not move, check for the presence of 24 Vac in the input.
5. If 24 Vac is present and motor does not operate, reverse controller leadwires to determine if device was miswired.
6. If the wiring is correct and 24 Vac is present on the input terminals but the motor does not run, replace the motor.

By using this Honeywell literature, you agree that Honeywell will have no liability for any damages arising out of your use or modification to, the literature. You will defend and indemnify Honeywell, its affiliates and subsidiaries, from and against any liability, cost, or damages, including attorneys' fees, arising out of, or resulting from, any modification to the literature by you.



# MicroMetl

---

MicroMetl Indianapolis  
3035 N. Shadeland Ave., Suite 300  
Indianapolis, IN 46226  
1.800.MMC.HVAC (EST)  
[indycustomerservice@micrometl.com](mailto:indycustomerservice@micrometl.com)

MicroMetl Longview  
201 Kodak Blvd.  
Longview, TX 75602  
1.903.248.4800 (CST)  
[longviewcustomerservice@micrometl.com](mailto:longviewcustomerservice@micrometl.com)

MicroMetl Sparks  
905 Southern Way  
Sparks, NV 89431  
1.800.884.4662 (PST)  
[sparkscustomerservice@micrometl.com](mailto:sparkscustomerservice@micrometl.com)