



POLYMER ADHESIVES
SEALANT SYSTEMS, INC.

FIRESTOP TECHNICAL PACK

FIRESEAL 814 Acrylic Intumescent Caulk

Polymer Adhesives Sealant Systems, Inc.
501 Garrett Morris Parkway
Mineral Wells, TX 76067

TEL: (888) 721-SEAL (7325)

FAX: (888) 921-SEAL (7325)

WWW.POLYMERADHESIVES.COM
SALES@POLYMERADHESIVES.COM



FIRESEAL 814

Intumescent Firestop Sealant

FEATURES

- Fire Rated
- Excellent Adhesion
- Flexible Set
- Water Based (Acrylic)
- 0 Slump (ASTM D2202)



FIRE RATED ACRYLIC

Fireseal 814 is an ASTM E814 rated one part water based acrylic intumescent sealant formulated to seal gaps in construction and through-penetrations against the passage of fire, smoke and gasses.

CHOOSE YOUR PRODUCT

PRODUCT CODE	COLOR	SIZE	TEXTURE	PACKAGING	PALLET WEIGHT
FS814-T		10.3 oz Tube	Smooth	12 - Tubes Per Case / 45 Cases Per Pallet / 540 Tubes	750 lbs

Rust Red

APPLICATION	TESTING & PERFORMANCE DATA	ADDITIONAL INFORMATION	UL SYSTEMS
Fireseal 814 is suitable for use around copper and steel pipes, steel conduits, electrical cables, data and telephone cables, PVC and CPVC pipes (up to 2" diameter), and HVAC ductwork	Tested in Accordance with ASTM E-84, UL 1479 UL Classified 1 and 2 hour Rating Please visit the UL website for details on our current system	Classified fill, void or cavity material through-penetration firestop system numbers	W-J-1188, W-J-1189, W-J-1190, W-J-3147, W-J-3148, W-J-3149, W-J-7076, W-L-1386, W-L-1387, W-L 1388, W-L-3283, W-L-3284, W-L-3285, W-L-7135

TYPICAL INSTALLATIONS

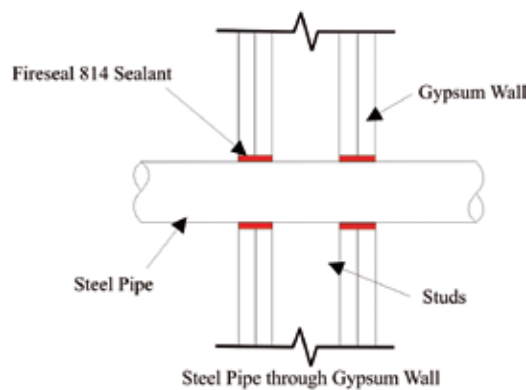
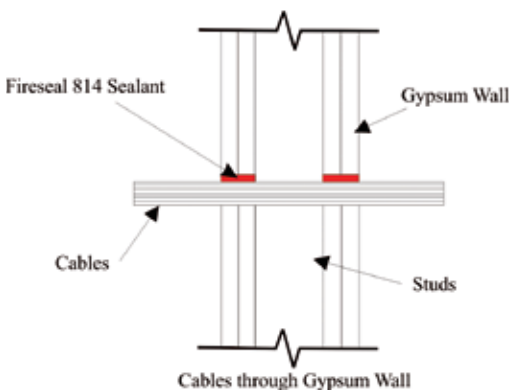

SCAN HERE TO VIEW MATERIAL SAFETY AND TECHNICAL INFORMATION FOR FIRESEAL 814



FIRESEAL™ 814

INTUMESCENT FIRESTOP SEALANT



FEATURES

- *Fire Rated*
- *Flexible Set*
- *VOC Compliant*
- *Excellent Adhesion*
- *Water Based (Acrylic)*
- *0 Slump (ASTM D2202)*

TECHNICAL SPECIFICATIONS	
Packaging	12 - 10.3 oz Tubes Per Case / 45 Cases Per Pallet / 540 Tubes
Shelf Life	12 months in unopened containers
Coverage Rates	10.3 oz. tube: 31 linear ft. 3/16" bead
Cure Time	Tack Free.....1 hour Full Cure.....48 hours Depending on temperature, humidity, and application thickness
Solid Content	80% ± 2% by weight
Weight Per Gallon	13.7 lbs. ± 0.3
VOC	133 grams/ltr.
Color	Iron Oxide Red
Temperature Limits	Application.....35°F to 110°F Service.....-4°F to 158°F Storage.....40°F to 86°F
Paintability	Latex.....When Cured Oil Base.....When Cured
Flame Spread	SURFACE BURNING CHARACTERISTICS Flame Spread0 Smoke Developed0 Meets Class 1 rating when tested to UL 723, ASTM E-84 and NFPA 90A, 90B, and 225.

DESCRIPTION

FIRESEAL 814 is an ASTM E-814 rated one part water based acrylic intumescent sealant formulated to seal gaps in construction and through penetrations against the passage of fire, smoke and gasses.

RECOMMENDED USES

FIRESEAL 814 has been tested where services penetrate through concrete walls, floors, and drywall construction, and is suitable for use around copper and steel pipes, steel conduits, electrical cables, data and telephone cables, PVC, CPVC pipes, and HVAC ducts.

APPLICATION INSTRUCTIONS

1. Areas to be sealed must be dry, clean and free from oil, grease and foreign matter.
2. Verify that any annular space between the through-penetration and the opening is within the limits defined by the tested constructions.
3. When mineral wool is required, cut oversize and pack tightly into space between the opening and the service, ensuring that the forming is positioned to allow for correct depth of **FIRESEAL 814** sealant (contingent upon system design).
4. Apply **FIRESEAL 814** using a conventional caulking gun, pneumatic gun, putty knife or trowel.
5. When desired depth of **FIRESEAL 814** sealant has been achieved, smooth surface with damp knife or spatula.

SPECIFICATION APPROVALS

Tested in accordance with ASTM E-814, UL 1479. UL Classified 1 and 2 Hour Rating.

SAFETY PRECAUTIONS

Consult Manufacturer's Material Safety Data Sheet.

FIRST AID: *For skin contact* -wash skin thoroughly with soap and water; *For eye contact* -irrigate with clean fresh water for at least 10 minutes holding eyelids apart, and seek medical advice; *If swallowed* - wash mouth with water and give water to drink. Do not induce vomiting. **KEEP OUT OF REACH OF CHILDREN.**

CLEAN UP

Use warm soapy water (when wet).

Polymer Adhesives Sealant Systems, Inc., is proud to be affiliated with the following organizations:



CLASSIFIED



POLYMER ADHESIVES

SEALANT SYSTEMS, INC.

www.polymeradhesives.com



MATERIAL SAFETY DATA SHEET

SECTION I

DISTRIBUTOR OR MANUFACTURER: Polymer Adhesives.		EMERGENCY TELEPHONE NO. CHEMTREC (800) 424-3900
ADDRESS (Number, Street, City, State and ZIP Code) 501 Garrett Morris Parkway Mineral Wells, TX 76067		
CHEMICAL FAMILY: Acrylic Latex	PRODUCT NAME AND SYNONYMS FIRESEAL 814 Caulk	
PRODUCT USE Intumescent Caulk	FORMULA Proprietary	

SECTION II - HAZARDOUS INGREDIENTS

HAZARDOUS INGREDIENTS	CAS NUMBER	%	PEL (ppm)			SKIN DESIGNATION	LD50 OF INGREDIENT (SPECIFY SPECIES AND ROUTE)	LD50 OF INGREDIENT (SPECIFY SPECIES)
			TWA	STEL	CEILING			
No OSHA PEL or NIOSH REL								

SECTION III - PHYSICAL DATA

PHYSICAL STATE Paste		ODOR AND APPEARANCE Paint odor Red		VOC (grams/liter) Less Water & Exempt Solvents N/A	ODOR THRESHOLD (ppm) N/A
VAPOR PRESSURE N/A	VAPOR DENSITY N/A	EVAPORATION RATE N/A	BOILING POINT (°C) N/A		FREEZING POINT N/A
pH N/A	SPECIFIC GRAVITY 1.62 - 1.66	COEFF. WATER/OIL DIST. N/A	SOLUBILITY IN WATER Miscible when wet		VOLATILES BY WT. (%) N/A

SECTION IV - FIRE AND EXPLOSION DATA

FLAMMABILITY		IF YES UNDER WHICH CONDITIONS?	
NO <input type="checkbox"/>		X <input checked="" type="checkbox"/>	
FLASHPOINT (°C) AND METHOD >100 C	AUTOIGNITION TEMPERATURE (°C)	LOWER FLAMMABLE LIMIT (% BY VOLUME) N/A	UPPER FLAMMABLE LIMIT (% BY VOLUME) N/A
HAZARDOUS COMBUSTION PRODUCTS Dense black smoke containing hazardous products of combustion			
EXPLOSION DATA	SENSITIVITY TO IMPACT Not Sensitive	SENSITIVITY TO STATIC DISCHARGE Not Sensitive	

NFPA CODE (REPRESENTATIVE OF THE MOST VOLATILE COMPONENTS IN THE SYSTEM)
Health - 1, Flammable - 0, Reactivity - 0, Protection - 1

EXTINGUISHING MEDIA
Alcohol resistant foam, carbon dioxide powder, or water spray or mist

SPECIAL FIRE FIGHTING PROCEDURES
Wear a self-contained breathing apparatus with a full face piece (MSHA-NIOSH Approval) in a pressure demand or other positive pressure mode when fighting fires.

UNUSUAL FIRE AND EXPLOSION HAZARDS
Material is not easily flammable, Cool containers if exposed to high temperatures. Spray containers itch cool water to reduce pressure build up. Store below 120° F.

SECTION V - REACTIVITY DATA

CHEMICAL STABILITY	UNSTABLE		HAZARDOUS POLYMERIZATION	MAY OCCUR		CONDITIONS TO AVOID Keep away from oxidizing agents and strongly alkaline and strong acidic materials to prevent possible exothermic reaction
	STABLE	X		WILL NOT OCCUR	X	

HAZARDOUS DECOMPOSITION PRODUCTS
Carbon dioxide and oxides of nitrogen

SECTION VI - TOXICOLOGICAL PROPERTIES

ROUTE OF ENTRY: SKIN CONTACT [] SKIN ABSORPTION [] EYE CONTACT [] INHALATION [] INGESTION []

EFFECTS OF ACUTE EXPOSURE TO PRODUCT

Eyes: Avoid contact may cause pain and irritation wear eye protection Ventilation: Use in well ventilated areas Skin: Avoid contact with skin may cause irritation wash hands Respiratory: Use in ventilation area no protection required

EFFECTS OF CHRONIC EXPOSURE TO PRODUCT

Minor irritation of eyes

EXPOSURE LIMITS None established	IRRITANCY OF PRODUCT N/A	SENSITIZATION TO PRODUCT N/A	CARCINOGENICITY None
TERATOGENICITY N/A	REPRODUCTIVE TOXICITY N/A	MUTAGENICITY N/A	SYNERGISTIC PRODUCTS N/A

SECTION VII - PREVENTATIVE MEASURES

PERSONAL PROTECTIVE EQUIPMENT		
GLOVES (SPECIFY) Wear gloves	RESPIRATOR (SPECIFY) Generally none required	EYE (SPECIFY) Wear eye protection
FOOTWEAR (SPECIFY) None required	CLOTHING (SPECIFY) Wash when contaminated	OTHER (SPECIFY) None

ENGINEERING CONTROLS (SPECIFY, E.G., VENTILATION, ENCLOSED PROCESS)
Use in ventilated area

LEAK OR SPILL PROCEDURE
Clean area and dispose of the material in accordance with local regulations

WASTE DISPOSAL
Product is considered to be an "article" as defined in the federal OSHA Hazard Communication Standard

HANDLING PROCEDURES AND EQUIPMENT
Avoid contact with strong acids or alkaline materials

STORAGE REQUIREMENTS
Store between 5 C and 25 C in a dry ventilated area away from heat sources. Protect from Frost. Store separately from oxidizing and

SPECIAL SHIPPING INFORMATION
Not regulated by DOT, IATA or IMDG [air or shipping] regulations

SECTION VIII - FIRST AID MEASURES

SPECIFIC MEASURES

Eye Contact: Wear eye protection if material gets in eyes rinse with saline solution for 15 minutes seek medical help if required.
Skin Contact: Wear gloves if skin becomes contaminated washing with soap and water
Inhalation: Use material in ventilated area, generally no respiratory protection is required
Ingestion: If accidentally swallowed wash mouth with water and give water to drink. Do not induce vomiting.

SECTION IX - SARA Section 313 SUPPLIER NOTIFICATION

CAS NUMBER	CHEMICAL NAME	PERCENT BY WEIGHT	CAS NUMBER	CHEMICAL NAME	PERCENT BY WEIGHT
	No OSHA PEL or NIOSH REL				

SECTION X - PREPARATION INFORMATION

PREPARED BY (GROUP, DEPARTMENT, ETC.) Research and Development	PHONE NUMBER (940) 328-9500	DATE 1/3/2013	CHANGE NO. 1	SUPERSEDES ALL PREVIOUS PUBLICATIONS
---	--------------------------------	------------------	-----------------	--------------------------------------

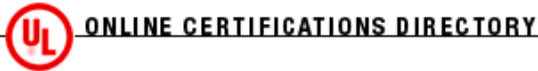

System No. W-J-1188 XHEZ.W-J-1188 Through-penetration Firestop Systems

[Page Bottom](#)

Design/System/Construction/Assembly Usage Disclaimer

- Authorities Having Jurisdiction should be consulted in all cases as to the particular requirements covering the installation and use of UL Certified products, equipment, system, devices, and materials.
- Authorities Having Jurisdiction should be consulted before construction.
- Fire resistance assemblies and products are developed by the design submitter and have been investigated by UL for compliance with applicable requirements. The published information cannot always address every construction nuance encountered in the field.
- When field issues arise, it is recommended the first contact for assistance be the technical service staff provided by the product manufacturer noted for the design. Users of fire resistance assemblies are advised to consult the general Guide Information for each product category and each group of assemblies. The Guide Information includes specifics concerning alternate materials and alternate methods of construction.
- Only products which bear UL's Mark are considered Certified.

Through-penetration Firestop Systems

[See General Information for Through-penetration Firestop Systems](#)

System No. W-J-1188

June 01, 2005

F Ratings — 1 and 2 Hr (See Item 1)

T Rating — 0 Hr

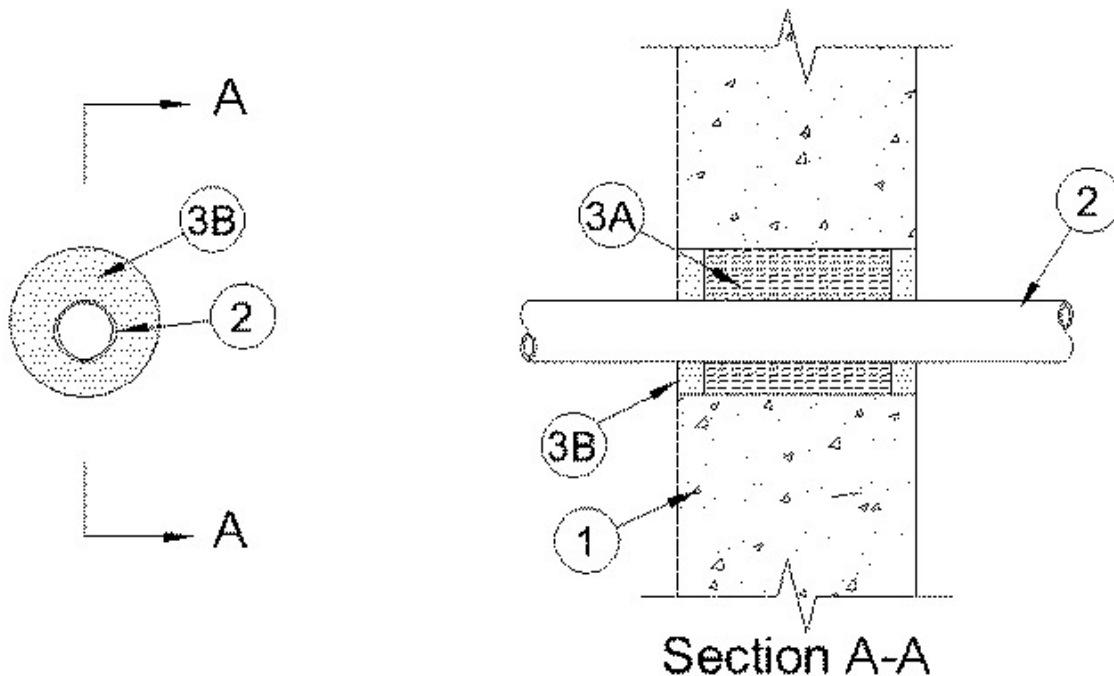

1. **Wall Assembly** — Min 4-7/8 or 6-1/8 in. (124 or 156 mm) thick lightweight or normal weight (100-150 pcf or 1600-2400 kg/m³) concrete for 1 and 2 hr rated assemblies, respectively. Wall may also be constructed of any UL Classified **Concrete Blocks***. Max diam of opening is 3 in. (76 mm).

See **Concrete Blocks** (CAZT) category in the UL Fire Resistance Directory for names of manufacturers.

The hourly F Rating of the firestop system is equal to the hourly fire rating of the wall assembly in which it is installed.

2. **Through Penetrating Product* - Flexible Metal Piping** — One nom 1-1/4 in. (32 mm) diam (or smaller) steel flexible metal piping to be installed either concentrically or eccentrically within the firestop system. The annular space shall be min 11/16 in. (18 mm) to max 1-1/16 in. (27 mm). Piping to be rigidly supported on both sides of wall assembly.

OMEGA FLEX INC

3. **Firestop System** — The firestop system shall consist of the following:

A. **Packing Material** — Min 3-7/8 or 5-1/8 in. (99 or 130 mm) thickness of min 4 pcf (64 kg/m³) mineral wool batt insulation firmly packed into opening as a permanent form for 1 or 2 hr fire rated walls, respectively. Packing material to be recessed from both surfaces of wall as required to accommodate the required thickness of fill material.

B. **Fill, Void or Cavity Material* - Caulk** — Min 1/2 in. (13 mm) thickness of fill material applied within the annulus, flush with both surfaces of wall.

POLYMER ADHESIVES SEALANT SYSTEMS INC — FireSeal 814

*Bearing the UL Classification Mark

Last Updated on 2005-06-01

[Questions?](#)

[Print this page](#)

[Terms of Use](#)

[Page Top](#)

© 2013 UL LLC

When the UL Leaf Mark is on the product, or when the word "Environment" is included in the UL Mark, please search the [UL Environment database](#) for additional information regarding this product's certification.

The appearance of a company's name or product in this database does not in itself assure that products so identified have been manufactured under UL's Follow-Up Service. Only those products bearing the UL Mark should be considered to be Certified and covered under UL's Follow-Up Service. Always look for the Mark on the product.

UL permits the reproduction of the material contained in the Online Certification Directory subject to the following conditions: 1. The Guide Information, Assemblies, Constructions, Designs, Systems, and/or Certifications (files) must be presented in their entirety and in a non-misleading manner, without any manipulation of the data (or drawings). 2. The statement "Reprinted from the Online Certifications Directory with permission from UL" must appear adjacent to the extracted material. In addition, the reprinted material must include a copyright notice in the following format: "© 2013 UL LLC".

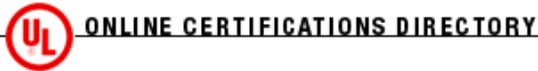

System No. W-J-1189 XHEZ.W-J-1189 Through-penetration Firestop Systems

[Page Bottom](#)

Design/System/Construction/Assembly Usage Disclaimer

- Authorities Having Jurisdiction should be consulted in all cases as to the particular requirements covering the installation and use of UL Certified products, equipment, system, devices, and materials.
- Authorities Having Jurisdiction should be consulted before construction.
- Fire resistance assemblies and products are developed by the design submitter and have been investigated by UL for compliance with applicable requirements. The published information cannot always address every construction nuance encountered in the field.
- When field issues arise, it is recommended the first contact for assistance be the technical service staff provided by the product manufacturer noted for the design. Users of fire resistance assemblies are advised to consult the general Guide Information for each product category and each group of assemblies. The Guide Information includes specifics concerning alternate materials and alternate methods of construction.
- Only products which bear UL's Mark are considered Certified.

Through-penetration Firestop Systems

[See General Information for Through-penetration Firestop Systems](#)

System No. W-J-1189

June 29, 2005

F Ratings — 1 and 2 Hr (See Item 1)

T Rating — 0 Hr

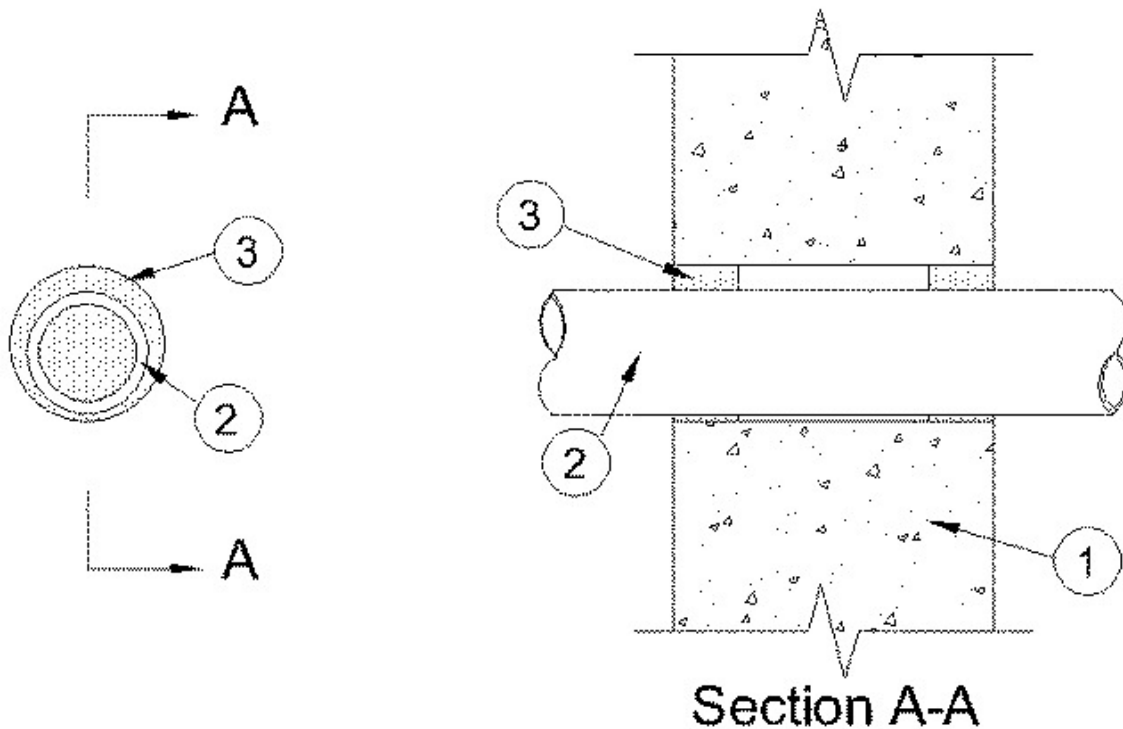

1. **Wall Assembly** — Min 4-7/8 or 6-1/8 in. (124 or 156 mm) thick lightweight or normal weight (100-150 pcf or 1600-2400 kg/m³) concrete for 1 and 2 hr rated assemblies, respectively. Wall may also be constructed of any UL Classified **Concrete Blocks***. Max diam of opening is 3 in. (76 mm).

See **Concrete Blocks** (CAZT) category in the UL Fire Resistance Directory for names of manufacturers.

2. **Through Penetrant** — One metallic pipe or conduit to be installed either concentrically or eccentrically within the firestop system. The annular space within the firestop system shall be min 1/8 in. (3 mm) to max 1/2 in. (13 mm). Pipe or conduit to be rigidly supported on both sides of wall assembly. The following types and sizes of pipe and conduit may be used:

A. **Steel Pipe** — Nom 2 in. (51 mm) diam (or smaller) Schedule 10 (or heavier) steel pipe.

B. **Iron Pipe** — Nom 2 in. (51 mm) diam (or smaller) cast or ductile iron pipe.

C. **Conduit** — Nom 2 in. (51 mm) diam (or smaller) rigid steel conduit or steel electrical metallic tubing.

3. **Fill, Void or Cavity Material* - Caulk** — Min 5/8 and 1-1/4 in. (16 and 32 mm) thickness of fill material for 1 and 2 hr rated assemblies, respectively, applied within the annulus, flush with both surfaces of wall.

POLYMER ADHESIVES SEALANT SYSTEMS INC — FireSeal 814

*Bearing the UL Classification Mark

Last Updated on 2005-06-29

[Questions?](#)

[Print this page](#)

[Terms of Use](#)

[Page Top](#)

© 2013 UL LLC

When the UL Leaf Mark is on the product, or when the word "Environment" is included in the UL Mark, please search the [UL Environment database](#) for additional information regarding this product's certification.

The appearance of a company's name or product in this database does not in itself assure that products so identified have been manufactured under UL's Follow-Up Service. Only those products bearing the UL Mark should be considered to be Certified and covered under UL's Follow-Up Service. Always look for the Mark on the product.

UL permits the reproduction of the material contained in the Online Certification Directory subject to the following conditions: 1. The Guide Information, Assemblies, Constructions, Designs, Systems, and/or Certifications (files) must be presented in their entirety and in a non-misleading manner, without any manipulation of the data (or drawings). 2. The statement "Reprinted from the Online Certifications Directory with permission from UL" must appear adjacent to the extracted material. In addition, the reprinted material must include a copyright notice in the following format: "© 2013 UL LLC".

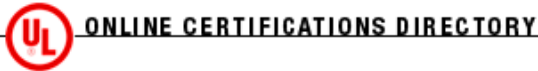

System No. W-J-1190 XHEZ.W-J-1190 Through-penetration Firestop Systems

[Page Bottom](#)

Design/System/Construction/Assembly Usage Disclaimer

- Authorities Having Jurisdiction should be consulted in all cases as to the particular requirements covering the installation and use of UL Certified products, equipment, system, devices, and materials.
- Authorities Having Jurisdiction should be consulted before construction.
- Fire resistance assemblies and products are developed by the design submitter and have been investigated by UL for compliance with applicable requirements. The published information cannot always address every construction nuance encountered in the field.
- When field issues arise, it is recommended the first contact for assistance be the technical service staff provided by the product manufacturer noted for the design. Users of fire resistance assemblies are advised to consult the general Guide Information for each product category and each group of assemblies. The Guide Information includes specifics concerning alternate materials and alternate methods of construction.
- Only products which bear UL's Mark are considered Certified.

Through-penetration Firestop Systems

[See General Information for Through-penetration Firestop Systems](#)

System No. W-J-1190

June 29, 2005

F Rating — 1 Hr

T Rating — 0 Hr

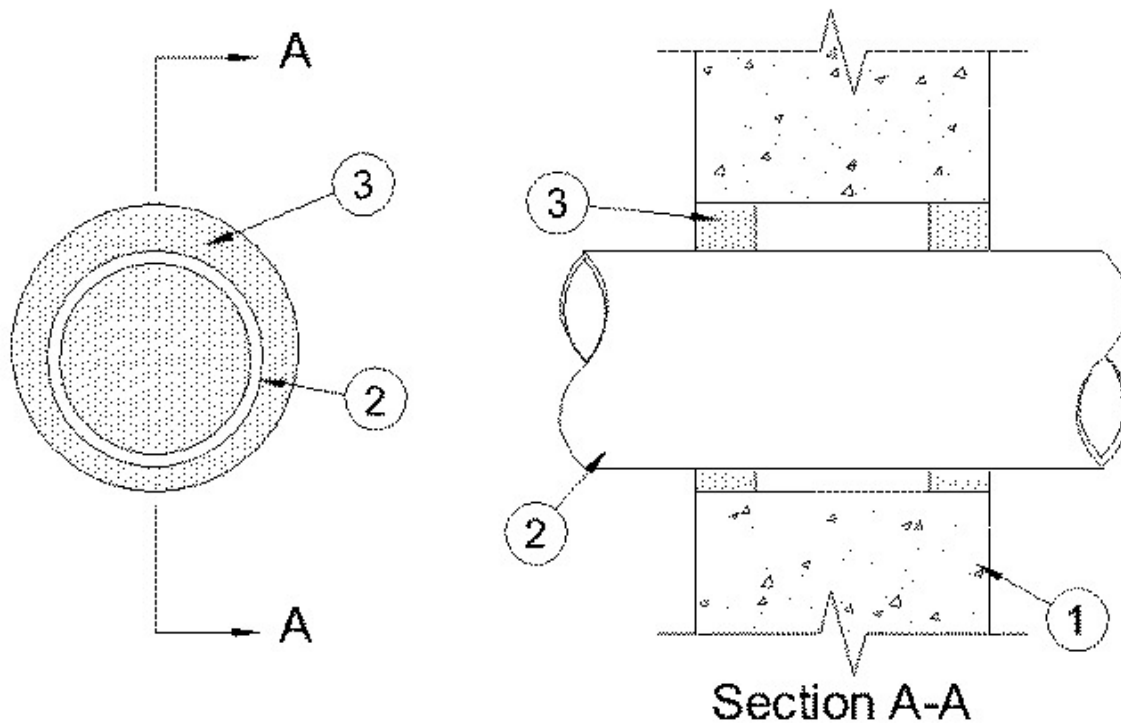

1. **Wall Assembly** — Min 4-7/8 in. (124 mm) thick lightweight or normal weight (100-150 pcf or 1600-2400 kg/m³) concrete. Wall may also be constructed of any UL Classified **Concrete Blocks***. Max diam of opening is 6 in. (152 mm).

See **Concrete Blocks** (CAZT) category in the UL Fire Resistance Directory for names of manufacturers.

2. **Through Penetrant** — One metallic pipe, tubing or conduit to be installed either concentrically or eccentrically within the firestop system. The annular space within the firestop system shall be min 1/2 in. (13 mm) to max 1 in. (25 mm). Pipe, conduit or tubing to be rigidly supported on both sides of wall assembly. The following types and sizes of pipe and conduit may be used:

- A. **Steel Pipe** — Nom 4 in. (102 mm) diam (or smaller) Schedule 10 (or heavier) steel pipe.
- B. **Iron Pipe** — Nom 4 in. (102 mm) diam (or smaller) cast or ductile iron pipe.
- C. **Conduit** — Nom 4 in. (102 mm) diam (or smaller) rigid steel conduit or steel electrical metallic tubing.
- D. **Copper Tubing** — Nom 2 in. (51 mm) diam (or smaller) Type L (or heavier) copper tubing.
- E. **Copper Pipe** — Nom 2 in. (51 mm) diam (or smaller) Regular (or heavier) copper pipe.

3. **Fill, Void or Cavity Material* - Caulk** — Min 5/8 in. (16 mm) thickness of fill material applied within the annulus, flush with both surfaces of wall.

POLYMER ADHESIVES SEALANT SYSTEMS INC — FireSeal 814

*Bearing the UL Classification Mark

Last Updated on 2005-06-29

[Questions?](#)

[Print this page](#)

[Terms of Use](#)

[Page Top](#)

© 2013 UL LLC

When the UL Leaf Mark is on the product, or when the word "Environment" is included in the UL Mark, please search the [UL Environment database](#) for additional information regarding this product's certification.

The appearance of a company's name or product in this database does not in itself assure that products so identified have been manufactured under UL's Follow-Up Service. Only those products bearing the UL Mark should be considered to be Certified and covered under UL's Follow-Up Service. Always look for the Mark on the product.

UL permits the reproduction of the material contained in the Online Certification Directory subject to the following conditions: 1. The Guide Information, Assemblies, Constructions, Designs, Systems, and/or Certifications (files) must be presented in their entirety and in a non-misleading manner, without any manipulation of the data (or drawings). 2. The statement "Reprinted from the Online Certifications Directory with permission from UL" must appear adjacent to the extracted material. In addition, the reprinted material must include a copyright notice in the following format: "© 2013 UL LLC".

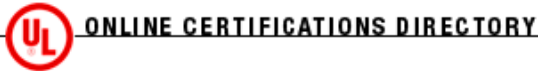

System No. W-J-3147 XHEZ.W-J-3147 Through-penetration Firestop Systems

[Page Bottom](#)

Design/System/Construction/Assembly Usage Disclaimer

- Authorities Having Jurisdiction should be consulted in all cases as to the particular requirements covering the installation and use of UL Certified products, equipment, system, devices, and materials.
- Authorities Having Jurisdiction should be consulted before construction.
- Fire resistance assemblies and products are developed by the design submitter and have been investigated by UL for compliance with applicable requirements. The published information cannot always address every construction nuance encountered in the field.
- When field issues arise, it is recommended the first contact for assistance be the technical service staff provided by the product manufacturer noted for the design. Users of fire resistance assemblies are advised to consult the general Guide Information for each product category and each group of assemblies. The Guide Information includes specifics concerning alternate materials and alternate methods of construction.
- Only products which bear UL's Mark are considered Certified.

Through-penetration Firestop Systems

[See General Information for Through-penetration Firestop Systems](#)

System No. W-J-3147

May 26, 2005

F Ratings — 1 and 2 Hr (See Item 1)

T Rating — 0 Hr

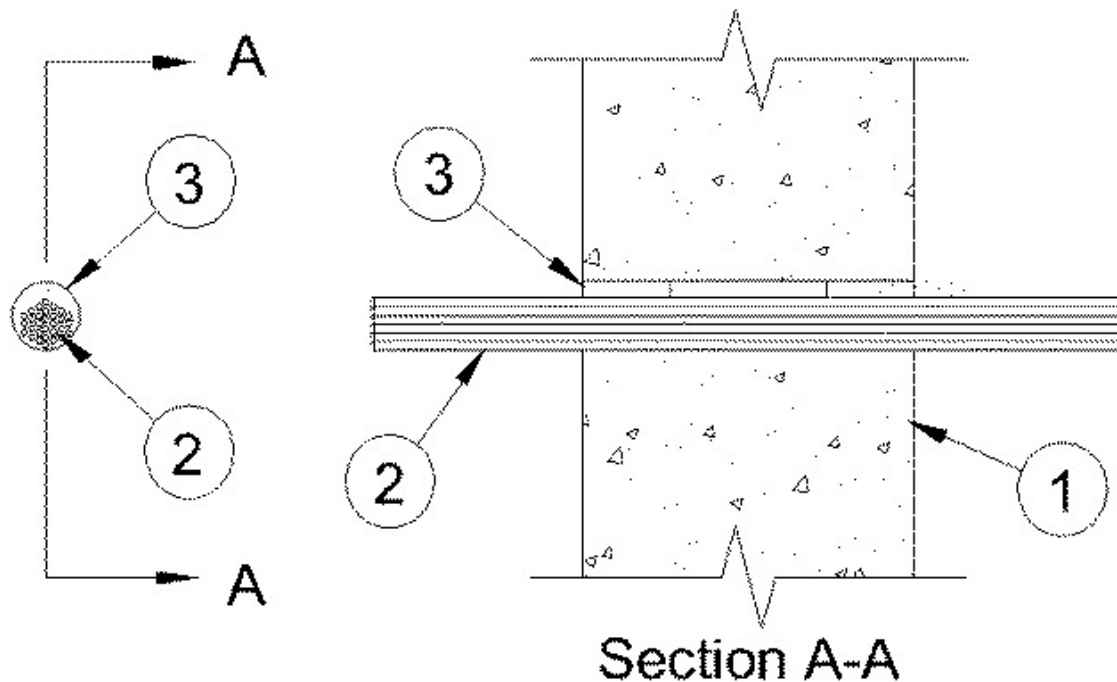

1. **Wall Assembly** — Min 4-7/8 or 6-1/8 in. (124 or 156 mm) thick lightweight or normal weight (100-150 pcf or 1600-2400 kg/m³) concrete for 1 and 2 hr rated assemblies, respectively. Wall may also be constructed of any UL Classified **Concrete Blocks***. Max diam of opening is 1 in. (25 mm).

See **Concrete Blocks** (CAZT) category in the UL Fire Resistance Directory for names of manufacturers.

The hourly F Rating of the firestop system is equal to the hourly fire rating of the wall assembly in which it is installed.

2. **Cables** — Max thirty, 4 pr. No. 24 AWG CMX,CMR or CAT 3 cables with polyvinyl chloride (PVC) insulation installed either concentrically or eccentrically within the firestop system. The annular space between the cable and the periphery of opening shall be min 0 in. (0 mm, point contact) to max 1/4 in. (25 mm). Cables to be tightly bundled and rigidly supported on both sides of wall assembly.

3. **Fill, Void or Cavity Material*** — **Caulk** — Min 1-1/4 in. (32 mm) thickness of fill material applied within the annulus, flush with both surfaces of wall.

POLYMER ADHESIVES SEALANT SYSTEMS INC — FireSeal 814

*Bearing the UL Classification Mark

Last Updated on 2005-05-26

[Questions?](#)

[Print this page](#)

[Terms of Use](#)

[Page Top](#)

© 2013 UL LLC

When the UL Leaf Mark is on the product, or when the word "Environment" is included in the UL Mark, please search the [UL Environment database](#) for additional information regarding this product's certification.

The appearance of a company's name or product in this database does not in itself assure that products so identified have been manufactured under UL's Follow-Up Service. Only those products bearing the UL Mark should be considered to be Certified and covered under UL's Follow-Up Service. Always look for the Mark on the product.

UL permits the reproduction of the material contained in the Online Certification Directory subject to the following conditions: 1. The Guide Information, Assemblies, Constructions, Designs, Systems, and/or Certifications (files) must be presented in their entirety and in a non-misleading manner, without any manipulation of the data (or drawings). 2. The statement "Reprinted from the Online Certifications Directory with permission from UL" must appear adjacent to the extracted material. In addition, the reprinted material must include a copyright notice in the following format: "© 2013 UL LLC".

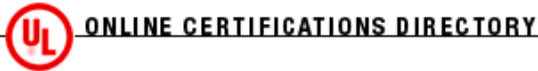

System No. W-J-3148 XHEZ.W-J-3148 Through-penetration Firestop Systems

[Page Bottom](#)

Design/System/Construction/Assembly Usage Disclaimer

- Authorities Having Jurisdiction should be consulted in all cases as to the particular requirements covering the installation and use of UL Certified products, equipment, system, devices, and materials.
- Authorities Having Jurisdiction should be consulted before construction.
- Fire resistance assemblies and products are developed by the design submitter and have been investigated by UL for compliance with applicable requirements. The published information cannot always address every construction nuance encountered in the field.
- When field issues arise, it is recommended the first contact for assistance be the technical service staff provided by the product manufacturer noted for the design. Users of fire resistance assemblies are advised to consult the general Guide Information for each product category and each group of assemblies. The Guide Information includes specifics concerning alternate materials and alternate methods of construction.
- Only products which bear UL's Mark are considered Certified.

Through-penetration Firestop Systems

[See General Information for Through-penetration Firestop Systems](#)

System No. W-J-3148

May 26, 2005

F Ratings — 1 and 2 Hr (See Item 1)

T Rating — 0 Hr

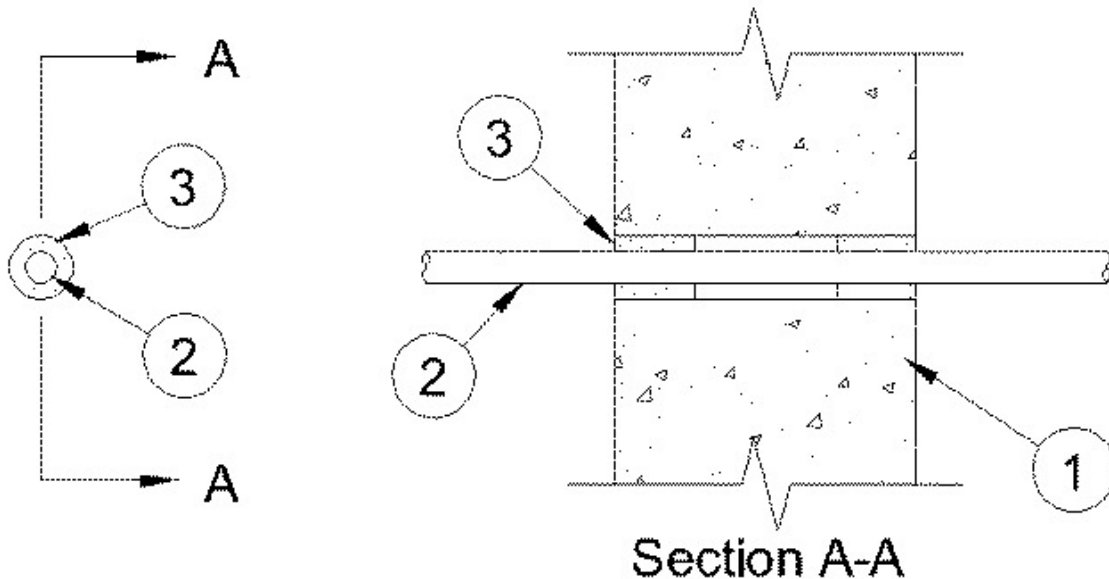

1. **Wall Assembly** — Min 4-7/8 or 6-1/8 in. (124 or 156 mm) thick lightweight or normal weight (100-150 pcf or 1600-2400 kg/m³) concrete for 1 and 2 hr rated assemblies, respectively. Wall may also be constructed of any UL Classified **Concrete Blocks***. Max diam of opening is 1 in. (25 mm).

See **Concrete Blocks** (CAZT) category in the UL Fire Resistance Directory for names of manufacturers.

The hourly F Rating of the firestop system is equal to the hourly fire rating of the wall assembly in which it is installed.

2. **Cable** — One max four conductor 14 AWG (or smaller) with PVC insulation and jacket installed concentrically within the firestop system. The annular space between the cable and the periphery of opening shall be 1/4 in. (6 mm). Cable to be rigidly supported on both sides of wall assembly.

3. **Fill, Void or Cavity Material* — Caulk** — Min 1-1/4 in. (32 mm) thickness of fill material applied within the annulus, flush with both surfaces of wall.

POLYMER ADHESIVES SEALANT SYSTEMS INC — FireSeal 814

*Bearing the UL Classification Mark

Last Updated on 2005-05-26

[Questions?](#)

[Print this page](#)

[Terms of Use](#)

[Page Top](#)

© 2013 UL LLC

When the UL Leaf Mark is on the product, or when the word "Environment" is included in the UL Mark, please search the [UL Environment database](#) for additional information regarding this product's certification.

The appearance of a company's name or product in this database does not in itself assure that products so identified have been manufactured under UL's Follow-Up Service. Only those products bearing the UL Mark should be considered to be Certified and covered under UL's Follow-Up Service. Always look for the Mark on the product.

UL permits the reproduction of the material contained in the Online Certification Directory subject to the following conditions: 1. The Guide Information, Assemblies, Constructions, Designs, Systems, and/or Certifications (files) must be presented in their entirety and in a non-misleading manner, without any manipulation of the data (or drawings). 2. The statement "Reprinted from the Online Certifications Directory with permission from UL" must appear adjacent to the extracted material. In addition, the reprinted material must include a copyright notice in the following format: "© 2013 UL LLC".

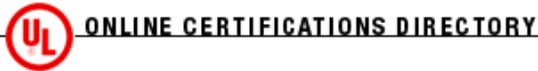

System No. W-J-3149 XHEZ.W-J-3149 Through-penetration Firestop Systems

[Page Bottom](#)

Design/System/Construction/Assembly Usage Disclaimer

- Authorities Having Jurisdiction should be consulted in all cases as to the particular requirements covering the installation and use of UL Certified products, equipment, system, devices, and materials.
- Authorities Having Jurisdiction should be consulted before construction.
- Fire resistance assemblies and products are developed by the design submitter and have been investigated by UL for compliance with applicable requirements. The published information cannot always address every construction nuance encountered in the field.
- When field issues arise, it is recommended the first contact for assistance be the technical service staff provided by the product manufacturer noted for the design. Users of fire resistance assemblies are advised to consult the general Guide Information for each product category and each group of assemblies. The Guide Information includes specifics concerning alternate materials and alternate methods of construction.
- Only products which bear UL's Mark are considered Certified.

Through-penetration Firestop Systems

[See General Information for Through-penetration Firestop Systems](#)

System No. W-J-3149

May 26, 2005

F Ratings — 1 and 2 Hr (See Item 1)

T Rating — 0 Hr

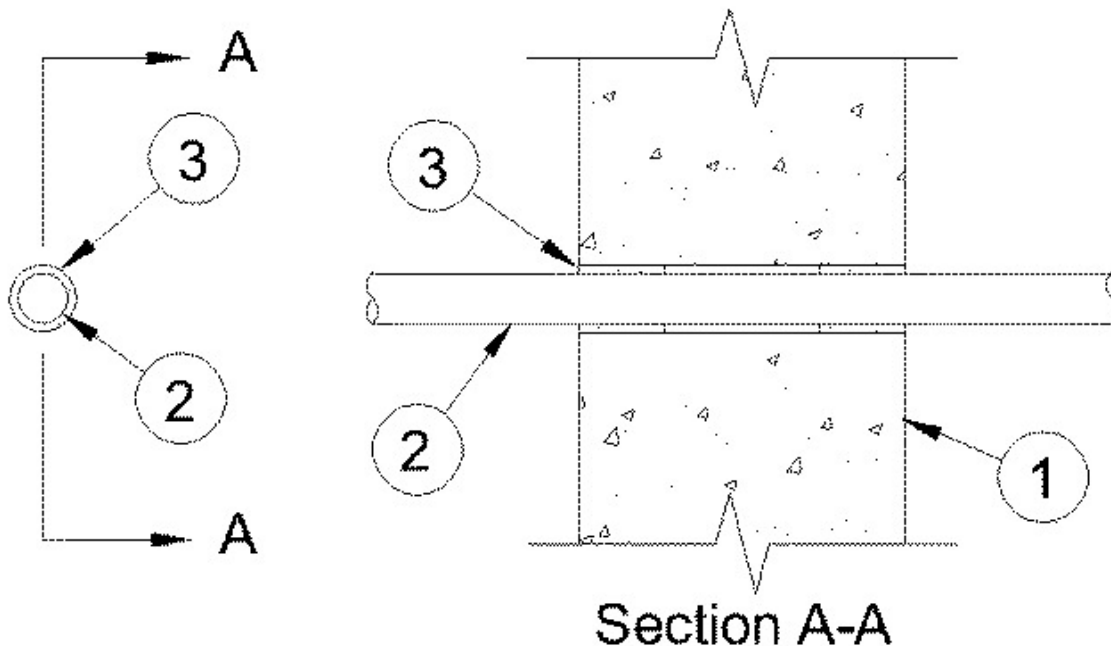

1. **Wall Assembly** — Min 4-7/8 or 6-1/8 in. (124 or 156 mm) thick lightweight or normal weight (100-150 pcf or 1600-2400 kg/m³) concrete for 1 and 2 hr rated assemblies, respectively. Wall may also be constructed of any UL Classified **Concrete Blocks***. Max diam of opening is 1 in. (25 mm).

See **Concrete Blocks** (CAZT) category in the UL Fire Resistance Directory for names of manufacturers.

The hourly F Rating of the firestop system is equal to the hourly fire rating of the wall assembly in which it is installed.

2. **Cable** — One max 48 strand optical fiber cable with PVC insulation and jacket installed concentrically within the firestop system. The annular space between the cable and the periphery of opening shall be 1/8 in. (3 mm). Cable to be rigidly supported on both sides of wall assembly.

3. **Fill, Void or Cavity Material* — Caulk** — Min 1-1/4 in. (32 mm) thickness of fill material applied within the annulus, flush with both surfaces of wall.

POLYMER ADHESIVES SEALANT SYSTEMS INC — FireSeal 814

*Bearing the UL Classification Mark

Last Updated on 2005-05-26

[Questions?](#)

[Print this page](#)

[Terms of Use](#)

[Page Top](#)

© 2013 UL LLC

When the UL Leaf Mark is on the product, or when the word "Environment" is included in the UL Mark, please search the [UL Environment database](#) for additional information regarding this product's certification.

The appearance of a company's name or product in this database does not in itself assure that products so identified have been manufactured under UL's Follow-Up Service. Only those products bearing the UL Mark should be considered to be Certified and covered under UL's Follow-Up Service. Always look for the Mark on the product.

UL permits the reproduction of the material contained in the Online Certification Directory subject to the following conditions: 1. The Guide Information, Assemblies, Constructions, Designs, Systems, and/or Certifications (files) must be presented in their entirety and in a non-misleading manner, without any manipulation of the data (or drawings). 2. The statement "Reprinted from the Online Certifications Directory with permission from UL" must appear adjacent to the extracted material. In addition, the reprinted material must include a copyright notice in the following format: "© 2013 UL LLC".

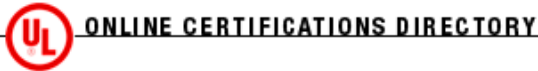

System No. W-J-7076 XHEZ.W-J-7076 Through-penetration Firestop Systems

[Page Bottom](#)

Design/System/Construction/Assembly Usage Disclaimer

- Authorities Having Jurisdiction should be consulted in all cases as to the particular requirements covering the installation and use of UL Certified products, equipment, system, devices, and materials.
- Authorities Having Jurisdiction should be consulted before construction.
- Fire resistance assemblies and products are developed by the design submitter and have been investigated by UL for compliance with applicable requirements. The published information cannot always address every construction nuance encountered in the field.
- When field issues arise, it is recommended the first contact for assistance be the technical service staff provided by the product manufacturer noted for the design. Users of fire resistance assemblies are advised to consult the general Guide Information for each product category and each group of assemblies. The Guide Information includes specifics concerning alternate materials and alternate methods of construction.
- Only products which bear UL's Mark are considered Certified.

Through-penetration Firestop Systems

[See General Information for Through-penetration Firestop Systems](#)

System No. W-J-7076

June 29, 2005

F Rating — 1 Hr

T Rating — 0 Hr

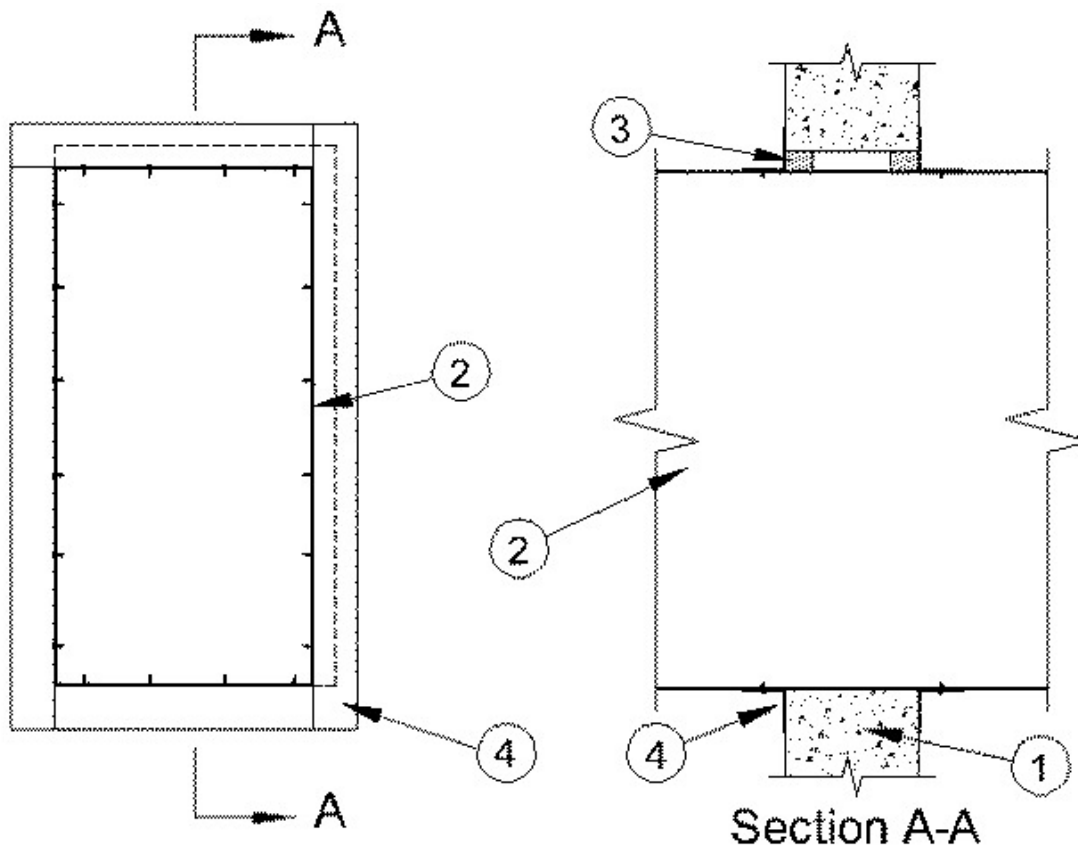

1. **Wall Assembly** — Min 4-7/8 in. (124 mm) thick lightweight or normal weight (100-150 pcf or 1600-2400 kg/m³) concrete. Wall may also be constructed of any UL Classified **Concrete Blocks***. Max size of opening is 325 in.2 (21.0 cm²) with a max dimension of opening 25 in. (635 mm).

See **Concrete Blocks** (CAZT) category in the UL Fire Resistance Directory for names of manufacturers.

2. **Steel Duct** — Max 12 by 24 in. (305 by 610 mm) by min 0.028 in. (0.71 mm) steel duct to be installed either concentrically or eccentrically within the opening. The annular space shall be min 0 in. (0 mm, point contact) to max 1 in. (25 mm). Duct to be rigidly supported on both sides of wall assembly.

3. **Fill, Void or Cavity Material* - Caulk** — Min 5/8 in. (16 mm) thickness of fill material applied within the annulus, flush with both surfaces of wall.

POLYMER ADHESIVES SEALANT SYSTEMS INC — FireSeal 814

4. **Steel Retaining Angles** — Min 2 by 2 by 0.030 in. (51 by 51 by 0.76 mm) steel angles attached to all four sides of duct on both sides of wall. The angles shall be attached to the duct with min 1/8 in. (3 mm) diam steel rivets or No. 8 (or larger) sheet metal screws spaced max 2 in. (51 mm) from each end of duct and spaced a max of 5 in. (127 mm) OC.

*Bearing the UL Classification Mark

Last Updated on 2005-06-29

[Questions?](#)

[Print this page](#)

[Terms of Use](#)

[Page Top](#)

© 2013 UL LLC

When the UL Leaf Mark is on the product, or when the word "Environment" is included in the UL Mark, please search the [UL Environment database](#) for additional information regarding this product's certification.

The appearance of a company's name or product in this database does not in itself assure that products so identified have been manufactured under UL's Follow-Up Service. Only those products bearing the UL Mark should be considered to be Certified and covered under UL's Follow-Up Service. Always look for the Mark on the product.

UL permits the reproduction of the material contained in the Online Certification Directory subject to the following conditions: 1. The Guide Information, Assemblies, Constructions, Designs, Systems, and/or Certifications (files) must be presented in their entirety and in a non-misleading manner, without any manipulation of the data (or drawings). 2. The statement "Reprinted from the Online Certifications Directory with permission from UL" must appear adjacent to the extracted material. In addition, the reprinted material must include a copyright notice in the following format: "© 2013 UL LLC".

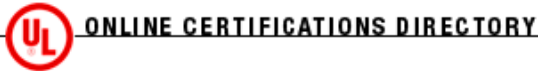

System No. W-L-1386
XHEZ.W-L-1386
Through-penetration Firestop Systems

[Page Bottom](#)

Design/System/Construction/Assembly Usage Disclaimer

- Authorities Having Jurisdiction should be consulted in all cases as to the particular requirements covering the installation and use of UL Certified products, equipment, system, devices, and materials.
- Authorities Having Jurisdiction should be consulted before construction.
- Fire resistance assemblies and products are developed by the design submitter and have been investigated by UL for compliance with applicable requirements. The published information cannot always address every construction nuance encountered in the field.
- When field issues arise, it is recommended the first contact for assistance be the technical service staff provided by the product manufacturer noted for the design. Users of fire resistance assemblies are advised to consult the general Guide Information for each product category and each group of assemblies. The Guide Information includes specifics concerning alternate materials and alternate methods of construction.
- Only products which bear UL's Mark are considered Certified.

Through-penetration Firestop Systems

[See General Information for Through-penetration Firestop Systems](#)

System No. W-L-1386

June 29, 2005

F Ratings — 1 and 2 Hr (See Item 1)

T Rating — 0 Hr

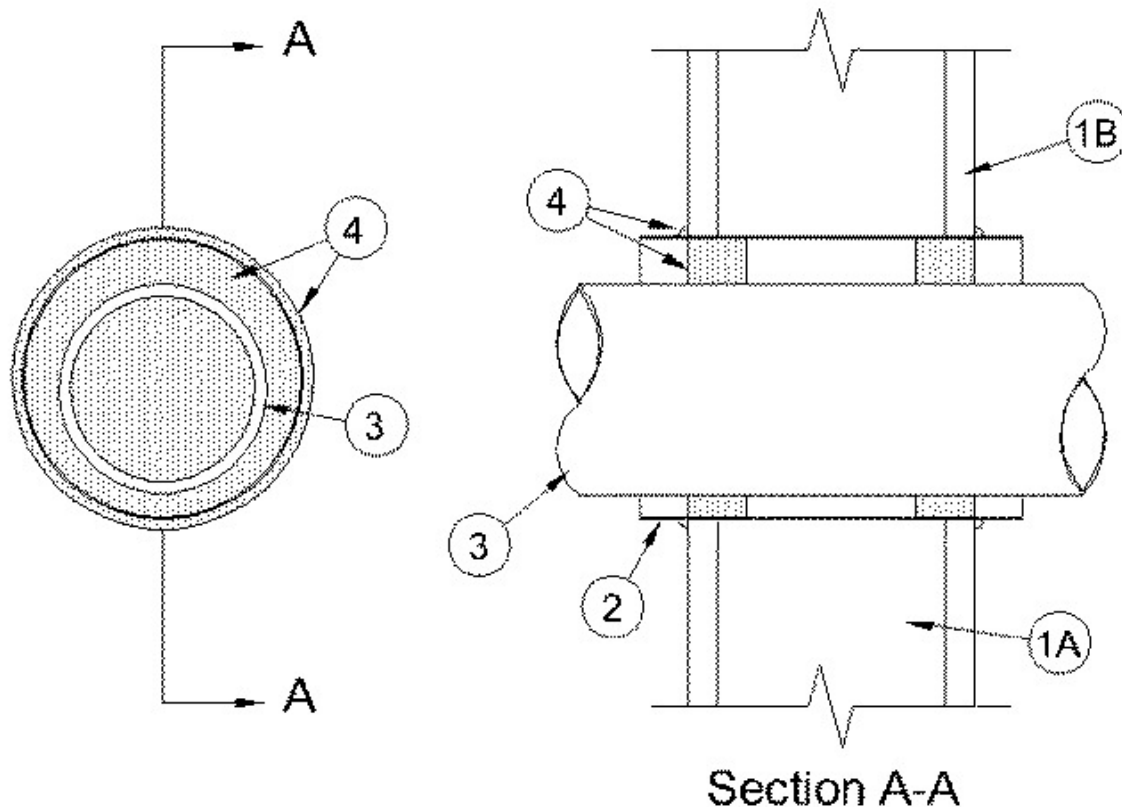

1. **Wall Assembly** — The 1 or 2 hr fire-rated gypsum board/stud wall assembly shall be constructed of the materials and in the manner specified in the individual U300, U400 or V400 Series Wall and Partition Designs in the UL Fire Resistance Directory and shall include the following construction features:

A. **Studs** — Wall framing shall consist of either wood or steel channel studs. Wood studs to consist of nom 2 by 4 in. (51 by 102 mm) lumber spaced 16 in. (406 mm) OC. Steel studs to be min 3-5/8 in. (92 mm) wide and spaced max 24 in. (610 mm) OC.

B. **Gypsum Board*** — Min 5/8 in. (16 mm) thick, 4 ft (1.22 m) wide with square or tapered edges. The gypsum board type, thickness, number of layers and orientation shall be as specified in the individual U300, U400 or V400 Series Wall and Partition Design. Max diam of opening is 3 in. (76 mm).

The hourly F Ratings of the firestop system are equal to the hourly fire rating of the wall assembly in which it is installed.

2. **Metallic Sleeve** — Cylindrical sleeve fabricated from nom 0.025 in. (0.64 mm) thick (or lighter) galv sheet steel and having a min 1 in. (25 mm) lap along the longitudinal seam. Length of steel sleeve to be equal to the thickness of the wall plus 2 in. (51 mm), such that when installed, the ends of the steel sleeve extend 1 in. (25 mm) beyond each surface of the wall. Sleeve installed by coiling the sheet steel to a diam smaller than the through opening, inserting the coil through the opening and releasing the coil to let it uncoil against the circular cutouts in the gypsum board layers.

3. **Through Penetrating Product* - Flexible Metal Piping** — One nom 1-1/4 in. (32 mm) diam (or smaller) steel flexible metal piping to be installed either concentrically or eccentrically within the firestop system. The annular space shall be min 11/16 in. (18 mm) to max 1-1/16 in. (27 mm). Piping to be rigidly supported on both sides of wall assembly.

OMEGA FLEX INC

4. **Firestop System** — The firestop system shall consist of the following:

A. **Packing Material** — Min 3-7/8 or 5-1/8 in. (98 or 130 mm) thickness of min 4 pcf (64 kg/m³) mineral wool batt insulation firmly packed into opening as a permanent form for 1 or 2 hr rated walls, respectively. Packing material to be recessed from both surfaces of wall as required to accommodate the required thickness of fill material.

B. **Fill, Void or Cavity Material* - Caulk** — Min 1/2 in. (13 mm) thickness of fill material applied within the annulus, flush with both surfaces of wall.

POLYMER ADHESIVES SEALANT SYSTEMS INC — FireSeal 814

*Bearing the UL Classification Mark

Last Updated on 2005-06-29

[Questions?](#)

[Print this page](#)

[Terms of Use](#)

[Page Top](#)

© 2013 UL LLC

When the UL Leaf Mark is on the product, or when the word "Environment" is included in the UL Mark, please search the [UL Environment database](#) for additional information regarding this product's certification.

The appearance of a company's name or product in this database does not in itself assure that products so identified have been manufactured under UL's Follow-Up Service. Only those products bearing the UL Mark should be considered to be Certified and covered under UL's Follow-Up Service. Always look for the Mark on the product.

UL permits the reproduction of the material contained in the Online Certification Directory subject to the following conditions: 1. The Guide Information, Assemblies, Constructions, Designs, Systems, and/or Certifications (files) must be presented in their entirety and in a non-misleading manner, without any manipulation of the data (or drawings). 2. The statement "Reprinted from the Online Certifications Directory with permission from UL" must appear adjacent to the extracted material. In addition, the reprinted material must include a copyright notice in the following format: "© 2013 UL LLC".

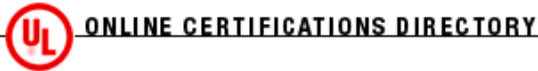

System No. W-L-1387
XHEZ.W-L-1387
Through-penetration Firestop Systems

Page Bottom

Design/System/Construction/Assembly Usage Disclaimer

- Authorities Having Jurisdiction should be consulted in all cases as to the particular requirements covering the installation and use of UL Certified products, equipment, system, devices, and materials.
- Authorities Having Jurisdiction should be consulted before construction.
- Fire resistance assemblies and products are developed by the design submitter and have been investigated by UL for compliance with applicable requirements. The published information cannot always address every construction nuance encountered in the field.
- When field issues arise, it is recommended the first contact for assistance be the technical service staff provided by the product manufacturer noted for the design. Users of fire resistance assemblies are advised to consult the general Guide Information for each product category and each group of assemblies. The Guide Information includes specifics concerning alternate materials and alternate methods of construction.
- Only products which bear UL's Mark are considered Certified.

Through-penetration Firestop Systems

See General Information for Through-penetration Firestop Systems

System No. W-L-1387

December 14, 2000

F Rating — 2 Hr

T Rating — 0 Hr

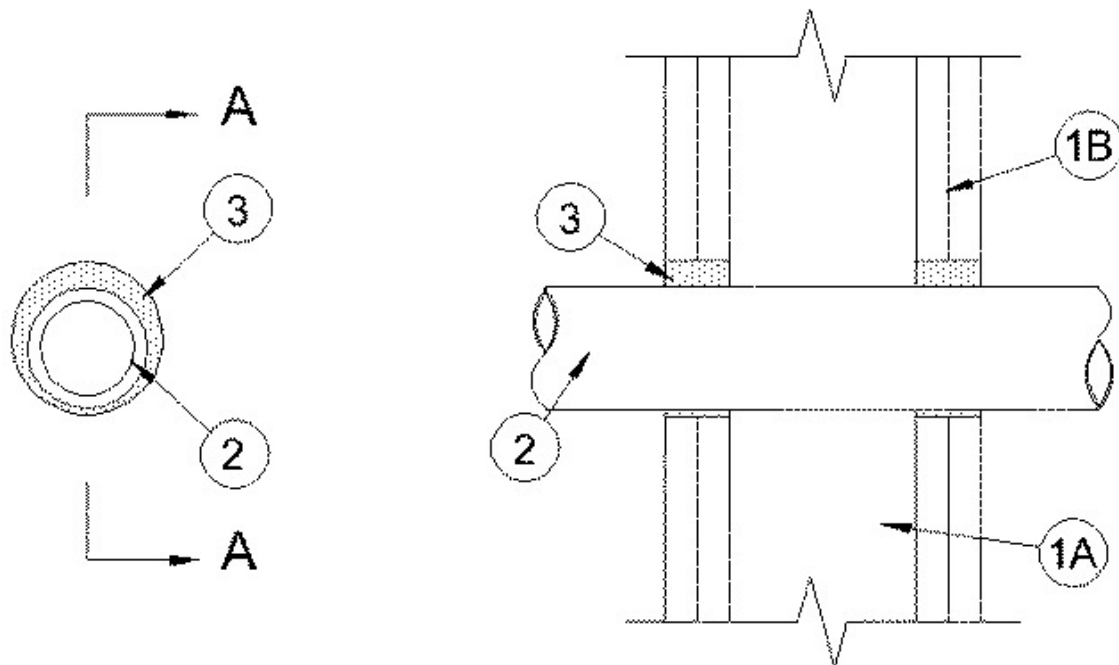

Section A-A

1. **Wall Assembly** — The 2 hr fire-rated gypsum board/stud wall assembly shall be constructed of the materials and in the manner specified in the individual U300, U400 or V400 Series Wall and Partition Designs in the UL Fire Resistance Directory and shall include the following construction features:

A. **Studs** — Wall framing shall consist of either wood or steel channel studs. Wood studs to consist of nom 2 by 4 in. (51 by 102 mm) lumber spaced 16 in. (406 mm) OC. Steel studs to be min 3-5/8 in. (92 mm) wide and spaced max 24 in. (610 mm) OC.

B. **Gypsum Board*** — Min 5/8 in. (16 mm) thick, 4 ft (1.22 m) wide with square or tapered edges. The gypsum board type, thickness, number of layers and orientation shall be as specified in the individual U300, U400 or V400 Series Wall and Partition Design. Max diam of opening is 3 in. (76 mm).

2. **Through Penetrant** — One metallic pipe or conduit to be installed either concentrically or eccentrically within the firestop system. The annular space within the firestop system shall be min 1/8 in. (3 mm) to max 1/2 in. (13 mm). Pipe or conduit to be rigidly supported on both sides of wall assembly. The following types and sizes of pipe and conduit may be used:

A. **Steel Pipe** — Nom 2 in. (51 mm) diam (or smaller) Schedule 10 (or heavier) steel pipe.

B. **Iron Pipe** — Nom 2 in. (51 mm) diam (or smaller) cast or ductile iron pipe.

C. **Conduit** — Nom 2 in. (51 mm) diam (or smaller) rigid steel conduit or steel electrical metallic tubing.

3. **Fill, Void or Cavity Material* - Caulk** — Min 1-1/4 in. (32 mm) thickness of fill material applied within the annulus, flush with both surfaces of wall.

POLYMER ADHESIVES SEALANT SYSTEMS INC — FireSeal 814

*Bearing the UL Classification Mark

Last Updated on 2000-12-14

[Questions?](#)

[Print this page](#)

[Terms of Use](#)

[Page Top](#)

© 2013 UL LLC

When the UL Leaf Mark is on the product, or when the word "Environment" is included in the UL Mark, please search the [UL Environment database](#) for additional information regarding this product's certification.

The appearance of a company's name or product in this database does not in itself assure that products so identified have been manufactured under UL's Follow-Up Service. Only those products bearing the UL Mark should be considered to be Certified and covered under UL's Follow-Up Service. Always look for the Mark on the product.

UL permits the reproduction of the material contained in the Online Certification Directory subject to the following conditions: 1. The Guide Information, Assemblies, Constructions, Designs, Systems, and/or Certifications (files) must be presented in their entirety and in a non-misleading manner, without any manipulation of the data (or drawings). 2. The statement "Reprinted from the Online Certifications Directory with permission from UL" must appear adjacent to the extracted material. In addition, the reprinted material must include a copyright notice in the following format: "© 2013 UL LLC".

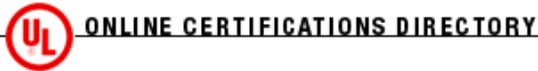

System No. W-L-1388
XHEZ.W-L-1388
Through-penetration Firestop Systems

[Page Bottom](#)

Design/System/Construction/Assembly Usage Disclaimer

- Authorities Having Jurisdiction should be consulted in all cases as to the particular requirements covering the installation and use of UL Certified products, equipment, system, devices, and materials.
- Authorities Having Jurisdiction should be consulted before construction.
- Fire resistance assemblies and products are developed by the design submitter and have been investigated by UL for compliance with applicable requirements. The published information cannot always address every construction nuance encountered in the field.
- When field issues arise, it is recommended the first contact for assistance be the technical service staff provided by the product manufacturer noted for the design. Users of fire resistance assemblies are advised to consult the general Guide Information for each product category and each group of assemblies. The Guide Information includes specifics concerning alternate materials and alternate methods of construction.
- Only products which bear UL's Mark are considered Certified.

Through-penetration Firestop Systems

[See General Information for Through-penetration Firestop Systems](#)

System No. W-L-1388

June 29, 2005

F Rating — 1 Hr

T Rating — 0 Hr

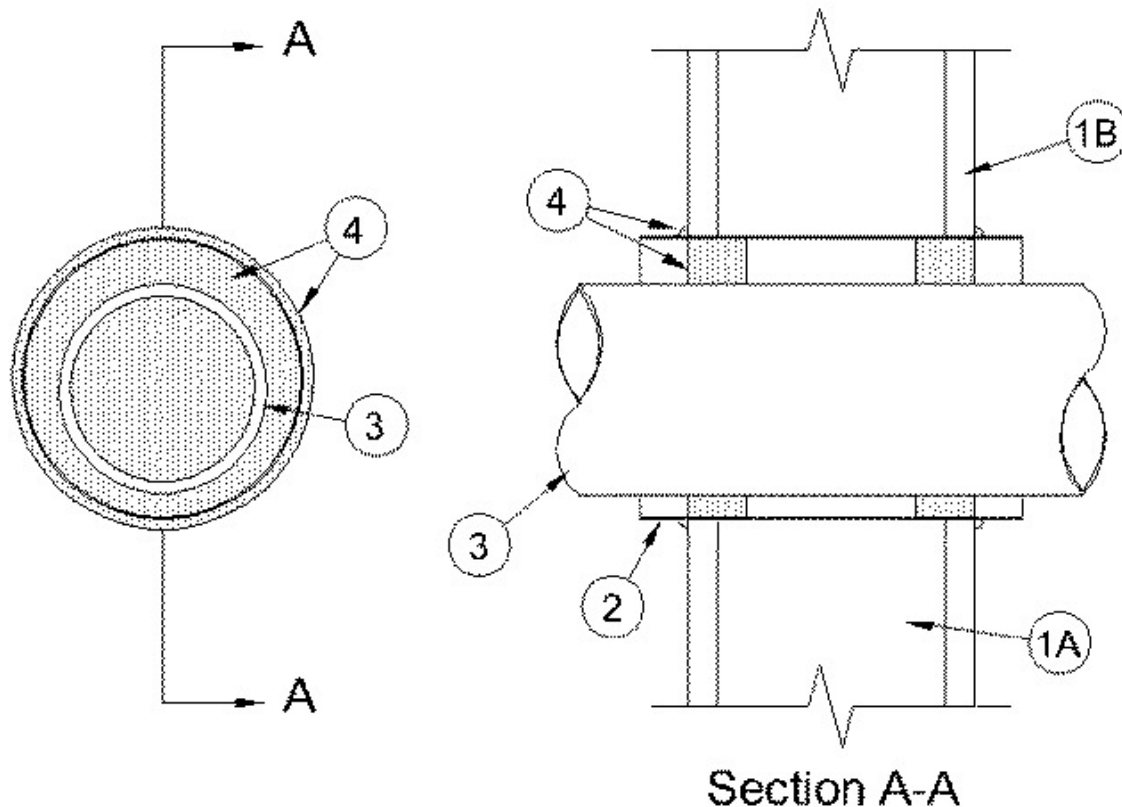

1. **Wall Assembly** — The 1 hr fire-rated gypsum board/stud wall assembly shall be constructed of the materials and in the manner specified in the individual U300, U400 or V400 Series Wall and Partition Designs in the UL Fire Resistance Directory and shall include the following construction features:

A. **Studs** — Wall framing shall consist of either wood or steel channel studs. Wood studs to consist of nom 2 by 4 in. (51 by 102 mm) lumber spaced 16 in. OC. Steel studs to be min 3-5/8 in. (92 mm) wide and spaced max 24 in. (610 mm) OC.

B. **Gypsum Board*** — Min 5/8 in. (16 mm) thick, 4 ft (1.22 m) wide with square or tapered edges. The gypsum board type, thickness, number of layers and orientation shall be as specified in the individual U300, U400 or V400 Series Wall and Partition Design. Max diam of opening is 6 in. (152 mm).

2. **Metallic Sleeve** — Max 6 in. diam cylindrical sleeve fabricated from min 0.025 in. (0.64 mm) thick galv sheet steel and having a min 1 in. (25 mm) lap along the longitudinal seam. Length of steel sleeve to be equal to the thickness of the wall plus 2 in. (51 mm), such that when installed, the ends of the steel sleeve extend 1 in. (25 mm) beyond each surface of the wall. Sleeve installed by coiling the sheet steel to a diam smaller than the through opening, inserting the coil through the opening and releasing the coil to let it uncoil against the circular cutouts in the gypsum board layers.

3. **Through Penetrant** — One metallic pipe, tubing or conduit to be installed either concentrically or eccentrically within the firestop system. The annular space within the firestop system shall be min 1/2 in. (13 mm) to max 1 in. (25 mm). Pipe, tubing or conduit to be rigidly supported on both sides of wall assembly. The following types and sizes of pipe, tubing or conduit may be used:

A. **Steel Pipe** — Nom 4 in. (102 mm) diam (or smaller) Schedule 10 (or heavier) steel pipe.

B. **Iron Pipe** — Nom 4 in. (102 mm) diam (or smaller) cast or ductile iron pipe.

C. **Conduit** — Nom 4 in. (102 mm) diam (or smaller) rigid steel conduit or steel electrical metallic tubing

D. **Copper Tubing** — Nom 2 in. (51 mm) diam (or smaller) Type L (or heavier) copper tubing.

E. **Copper Pipe** — Nom 2 in. (51 mm) diam (or smaller) Regular (or heavier) copper pipe.

4. **Firestop System** — The firestop system shall consist of the following:

A. **Packing Material** — Min 3-3/4 in. (95 mm) thickness of min 4 pcf (64 kg/m³) mineral wool batt insulation firmly packed into sleeved opening as a permanent form. Packing material to be recessed from both surfaces of wall as required to accommodate the required thickness of fill material.

B. **Fill, Void or Cavity Material* - Caulk** — Min 1/2 in. (13 mm) thickness of fill material applied within the annulus, flush with both surfaces of wall. Min 1/4 in. (6 mm) thick bead of fill material applied around annulus at the sleeve/wall surface interface on both sides of wall.

POLYMER ADHESIVES SEALANT SYSTEMS INC — FireSeal 814

*Bearing the UL Classification Mark

Last Updated on 2005-06-29

[Questions?](#)

[Print this page](#)

[Terms of Use](#)

[Page Top](#)

© 2013 UL LLC

When the UL Leaf Mark is on the product, or when the word "Environment" is included in the UL Mark, please search the [UL Environment database](#) for additional information regarding this product's certification.

The appearance of a company's name or product in this database does not in itself assure that products so identified have been manufactured under UL's Follow-Up Service. Only those products bearing the UL Mark should be considered to be Certified and covered under UL's Follow-Up Service. Always look for the Mark on the product.

UL permits the reproduction of the material contained in the Online Certification Directory subject to the following conditions: 1. The Guide Information, Assemblies, Constructions, Designs, Systems, and/or Certifications (files) must be presented in their entirety and in a non-misleading manner, without any manipulation of the data (or drawings). 2. The statement "Reprinted from the Online Certifications Directory with permission from UL" must appear adjacent to the extracted material. In addition, the reprinted material must include a copyright notice in the following format: "© 2013 UL LLC".

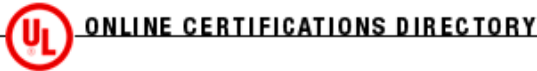

System No. W-L-3283
XHEZ.W-L-3283
Through-penetration Firestop Systems

Page Bottom

Design/System/Construction/Assembly Usage Disclaimer

- Authorities Having Jurisdiction should be consulted in all cases as to the particular requirements covering the installation and use of UL Certified products, equipment, system, devices, and materials.
- Authorities Having Jurisdiction should be consulted before construction.
- Fire resistance assemblies and products are developed by the design submitter and have been investigated by UL for compliance with applicable requirements. The published information cannot always address every construction nuance encountered in the field.
- When field issues arise, it is recommended the first contact for assistance be the technical service staff provided by the product manufacturer noted for the design. Users of fire resistance assemblies are advised to consult the general Guide Information for each product category and each group of assemblies. The Guide Information includes specifics concerning alternate materials and alternate methods of construction.
- Only products which bear UL's Mark are considered Certified.

Through-penetration Firestop Systems

See General Information for Through-penetration Firestop Systems

System No. W-L-3283

May 26, 2005

F Rating — 2 Hr

T Rating — 0 Hr

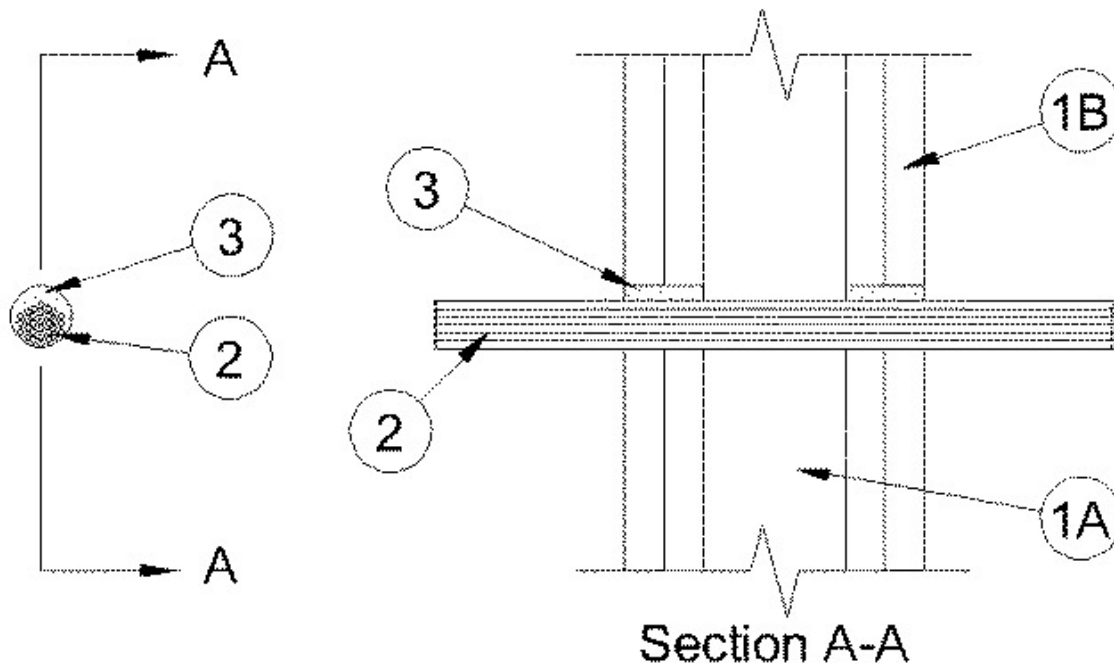

1. Wall Assembly — The 2 hr fire rated gypsum board/stud wall assembly shall be constructed of the materials and in the manner specified in the individual U300, U400 or V400 Series Wall and Partition Designs in the UL Fire Resistance Directory and shall include the following construction features:

A. Studs — Wall framing shall consist of either wood or steel channel studs. Wood studs to consist of nom 2 by 4 in. (51 by 102 mm) lumber spaced 16 in. (406 mm) OC. Steel studs to be min 3-5/8 in. (92 mm) wide and spaced max 24 in. (610 mm)OC.

B. **Gypsum Board*** — Min 5/8 in. (16mm) thick, 4 ft (1.22 m) wide with square or tapered edges. The gypsum board type, thickness, number of layers and orientation shall be as specified in the individual U300, U400 or V400 Series Wall and Partition Design. Max diam of opening is 1 in. (25 mm).

2. **Cables** — Max thirty, 4 pr. No. 24 AWG CMX,CMR or CAT 3 cables with polyvinyl chloride (PVC) insulation installed either concentrically or eccentrically within the firestop system. The annular space between the cable and the periphery of opening shall be min 0 in. (0 mm, point contact) to max 1/4 in. (6 mm). Cables to be tightly bundled and rigidly supported on both sides of wall assembly.

3. **Fill, Void or Cavity Material* — Caulk** — Min 1-1/4 in. (32 mm) thickness of fill material applied within the annulus, flush with both surfaces of wall.

POLYMER ADHESIVES SEALANT SYSTEMS INC — FireSeal 814

*Bearing the UL Classification Mark

Last Updated on 2005-05-26

[Questions?](#)

[Print this page](#)

[Terms of Use](#)

[Page Top](#)

© 2013 UL LLC

When the UL Leaf Mark is on the product, or when the word "Environment" is included in the UL Mark, please search the [UL Environment database](#) for additional information regarding this product's certification.

The appearance of a company's name or product in this database does not in itself assure that products so identified have been manufactured under UL's Follow-Up Service. Only those products bearing the UL Mark should be considered to be Certified and covered under UL's Follow-Up Service. Always look for the Mark on the product.

UL permits the reproduction of the material contained in the Online Certification Directory subject to the following conditions: 1. The Guide Information, Assemblies, Constructions, Designs, Systems, and/or Certifications (files) must be presented in their entirety and in a non-misleading manner, without any manipulation of the data (or drawings). 2. The statement "Reprinted from the Online Certifications Directory with permission from UL" must appear adjacent to the extracted material. In addition, the reprinted material must include a copyright notice in the following format: "© 2013 UL LLC".

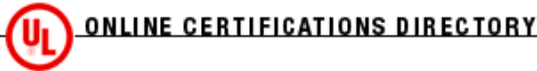

System No. W-L-3284 XHEZ.W-L-3284 Through-penetration Firestop Systems

[Page Bottom](#)

Design/System/Construction/Assembly Usage Disclaimer

- Authorities Having Jurisdiction should be consulted in all cases as to the particular requirements covering the installation and use of UL Certified products, equipment, system, devices, and materials.
- Authorities Having Jurisdiction should be consulted before construction.
- Fire resistance assemblies and products are developed by the design submitter and have been investigated by UL for compliance with applicable requirements. The published information cannot always address every construction nuance encountered in the field.
- When field issues arise, it is recommended the first contact for assistance be the technical service staff provided by the product manufacturer noted for the design. Users of fire resistance assemblies are advised to consult the general Guide Information for each product category and each group of assemblies. The Guide Information includes specifics concerning alternate materials and alternate methods of construction.
- Only products which bear UL's Mark are considered Certified.

Through-penetration Firestop Systems

[See General Information for Through-penetration Firestop Systems](#)

System No. W-L-3284

May 26, 2005

F Rating — 2 Hr

T Rating — 0 Hr

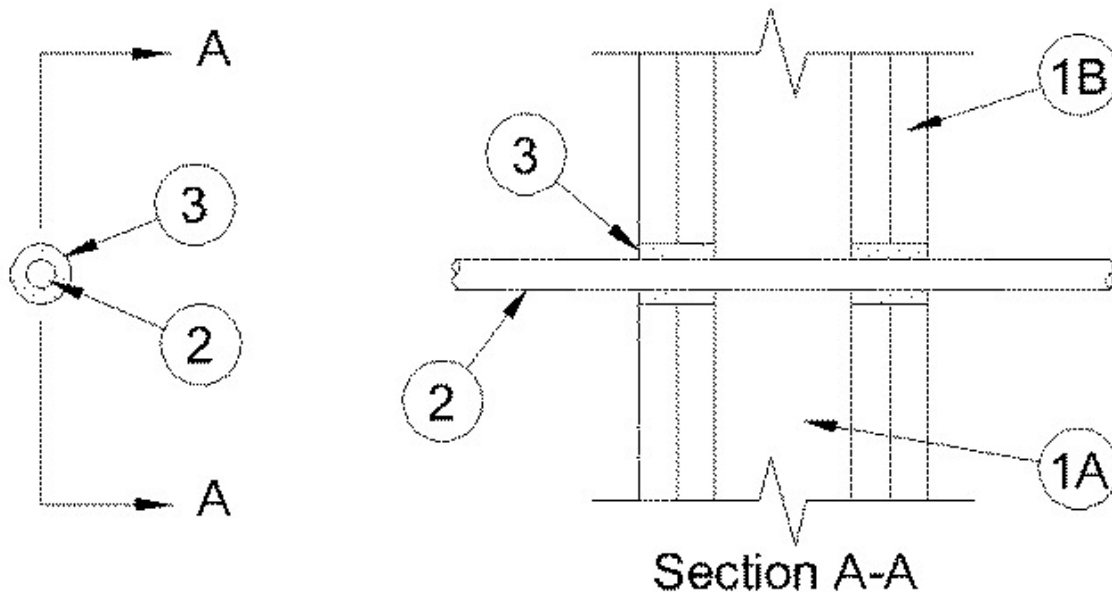

1. **Wall Assembly** — The 2 hr fire rated gypsum board/stud wall assembly shall be constructed of the materials and in the manner specified in the individual U300, U400 or V400 Series Wall and Partition Design in the UL Fire Resistance Directory and shall include the following construction features:

A. **Studs** — Wall framing shall consist of either wood or steel channel studs. Wood studs to consist of nom 2 by 4 in. (51 by 102 mm) lumber spaced 16 in. (406 mm) OC. Steel studs to be min 3-5/8 in. (92 mm) wide and spaced max 24 in. (610 mm) OC.

B. **Gypsum Board*** — Min 5/8 in. (16 mm) thick, 4 ft (1.22 m) wide with square or tapered edges. The gypsum board type, thickness, number of layers and orientation shall be as specified in the individual U300, U400 or V400 Series Wall and Partition Design. Max diam of opening is 1 in. (25 mm).

2. **Cable** — One max four conductor 14 AWG (or smaller) with PVC insulation and jacket installed concentrically within the firestop system. The annular space between the cable and the periphery of opening shall be 1/4 in. (6 mm). Cable to be rigidly supported on both sides of wall assembly.

3. **Fill, Void or Cavity Material* — Caulk** — Min 1-1/4 in. (32 mm) thickness of fill material applied within the annulus, flush with both surfaces of wall.

POLYMER ADHESIVES SEALANT SYSTEMS INC — FireSeal 814

*Bearing the UL Classification Mark

Last Updated on 2005-05-26

[Questions?](#)

[Print this page](#)

[Terms of Use](#)

[Page Top](#)

© 2013 UL LLC

When the UL Leaf Mark is on the product, or when the word "Environment" is included in the UL Mark, please search the [UL Environment database](#) for additional information regarding this product's certification.

The appearance of a company's name or product in this database does not in itself assure that products so identified have been manufactured under UL's Follow-Up Service. Only those products bearing the UL Mark should be considered to be Certified and covered under UL's Follow-Up Service. Always look for the Mark on the product.

UL permits the reproduction of the material contained in the Online Certification Directory subject to the following conditions: 1. The Guide Information, Assemblies, Constructions, Designs, Systems, and/or Certifications (files) must be presented in their entirety and in a non-misleading manner, without any manipulation of the data (or drawings). 2. The statement "Reprinted from the Online Certifications Directory with permission from UL" must appear adjacent to the extracted material. In addition, the reprinted material must include a copyright notice in the following format: "© 2013 UL LLC".

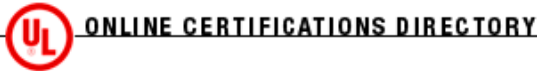

System No. W-L-3285
XHEZ.W-L-3285
Through-penetration Firestop Systems

[Page Bottom](#)

Design/System/Construction/Assembly Usage Disclaimer

- Authorities Having Jurisdiction should be consulted in all cases as to the particular requirements covering the installation and use of UL Certified products, equipment, system, devices, and materials.
- Authorities Having Jurisdiction should be consulted before construction.
- Fire resistance assemblies and products are developed by the design submitter and have been investigated by UL for compliance with applicable requirements. The published information cannot always address every construction nuance encountered in the field.
- When field issues arise, it is recommended the first contact for assistance be the technical service staff provided by the product manufacturer noted for the design. Users of fire resistance assemblies are advised to consult the general Guide Information for each product category and each group of assemblies. The Guide Information includes specifics concerning alternate materials and alternate methods of construction.
- Only products which bear UL's Mark are considered Certified.

Through-penetration Firestop Systems

[See General Information for Through-penetration Firestop Systems](#)

System No. W-L-3285

May 26, 2005

F Rating — 2 Hr

T Rating — 0 Hr

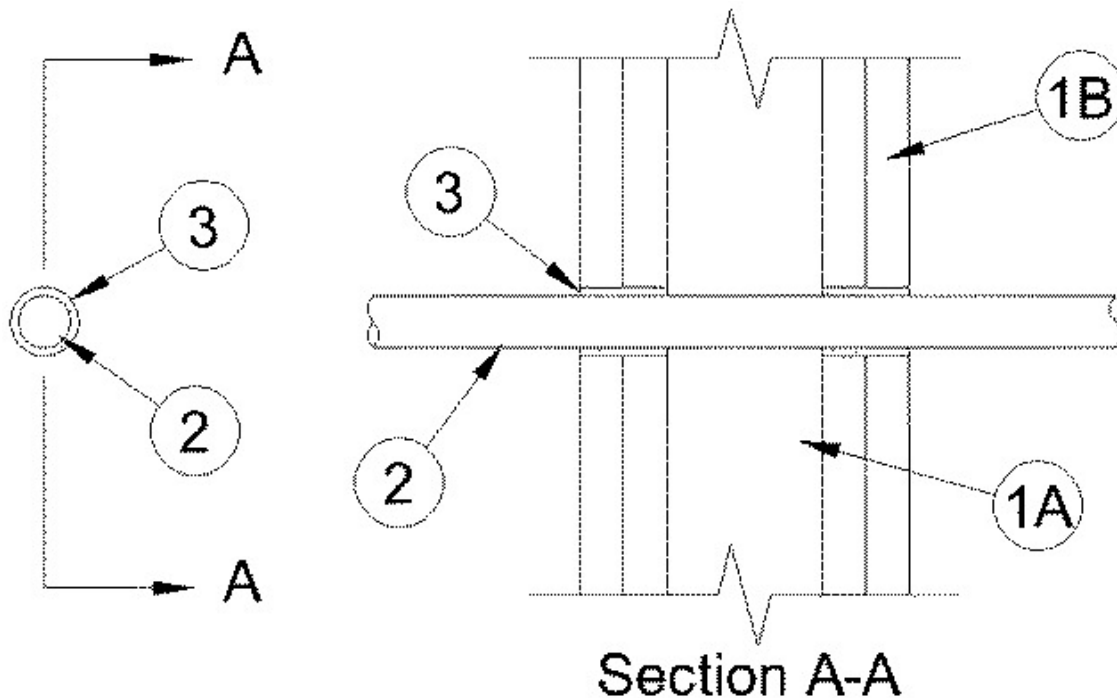

1. Wall Assembly — The 2 hr fire rated gypsum board/stud wall assembly shall be constructed of the materials and in the manner specified in the individual U300, U400 or V400 Series Wall and Partition Designs in the UL Fire Resistance Directory and shall include the following construction features:

A. Studs — Wall framing shall consist of either wood or steel channel studs. Wood studs to consist of nom 2 by 4 in. (51 by 102 mm) lumber spaced 16 in. (406 mm) OC. Steel studs to be min 3-5/8 in. (92 mm) wide and spaced max 24 in. (610 mm) OC.

B. **Gypsum Board*** — Min 5/8 in. (16 mm) thick, 4 ft (1.22 m) wide with square or tapered edges. The gypsum wallboard type, thickness, number of layers and orientation shall be as specified in the individual U300, U400 or V400 Series Wall and Partition Design. Max diam of opening is 1 in. (25 mm).

2. **Cable** — One max 48 strand optical fiber cable with PVC insulation and jacket installed concentrically within the firestop system. The annular space between the cable and the periphery of opening shall be 1/8 in. (3 mm) Cable to be rigidly supported on both sides of wall assembly.

3. **Fill, Void or Cavity Material* — Caulk** — Min 1-1/4 in. (32 mm) thickness of fill material applied within the annulus, flush with both surfaces of wall.

POLYMER ADHESIVES SEALANT SYSTEMS INC — FireSeal 814

*Bearing the UL Classification Mark

Last Updated on 2005-05-26

[Questions?](#)

[Print this page](#)

[Terms of Use](#)

[Page Top](#)

© 2013 UL LLC

When the UL Leaf Mark is on the product, or when the word "Environment" is included in the UL Mark, please search the [UL Environment database](#) for additional information regarding this product's certification.

The appearance of a company's name or product in this database does not in itself assure that products so identified have been manufactured under UL's Follow-Up Service. Only those products bearing the UL Mark should be considered to be Certified and covered under UL's Follow-Up Service. Always look for the Mark on the product.

UL permits the reproduction of the material contained in the Online Certification Directory subject to the following conditions: 1. The Guide Information, Assemblies, Constructions, Designs, Systems, and/or Certifications (files) must be presented in their entirety and in a non-misleading manner, without any manipulation of the data (or drawings). 2. The statement "Reprinted from the Online Certifications Directory with permission from UL" must appear adjacent to the extracted material. In addition, the reprinted material must include a copyright notice in the following format: "© 2013 UL LLC".

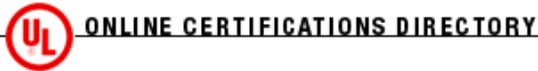

System No. W-L-7135
XHEZ.W-L-7135
Through-penetration Firestop Systems

Page Bottom

Design/System/Construction/Assembly Usage Disclaimer

- Authorities Having Jurisdiction should be consulted in all cases as to the particular requirements covering the installation and use of UL Certified products, equipment, system, devices, and materials.
- Authorities Having Jurisdiction should be consulted before construction.
- Fire resistance assemblies and products are developed by the design submitter and have been investigated by UL for compliance with applicable requirements. The published information cannot always address every construction nuance encountered in the field.
- When field issues arise, it is recommended the first contact for assistance be the technical service staff provided by the product manufacturer noted for the design. Users of fire resistance assemblies are advised to consult the general Guide Information for each product category and each group of assemblies. The Guide Information includes specifics concerning alternate materials and alternate methods of construction.
- Only products which bear UL's Mark are considered Certified.

Through-penetration Firestop Systems

See General Information for Through-penetration Firestop Systems

System No. W-L-7135

June 29, 2005

F Rating — 1 Hr

T Rating — 0 Hr

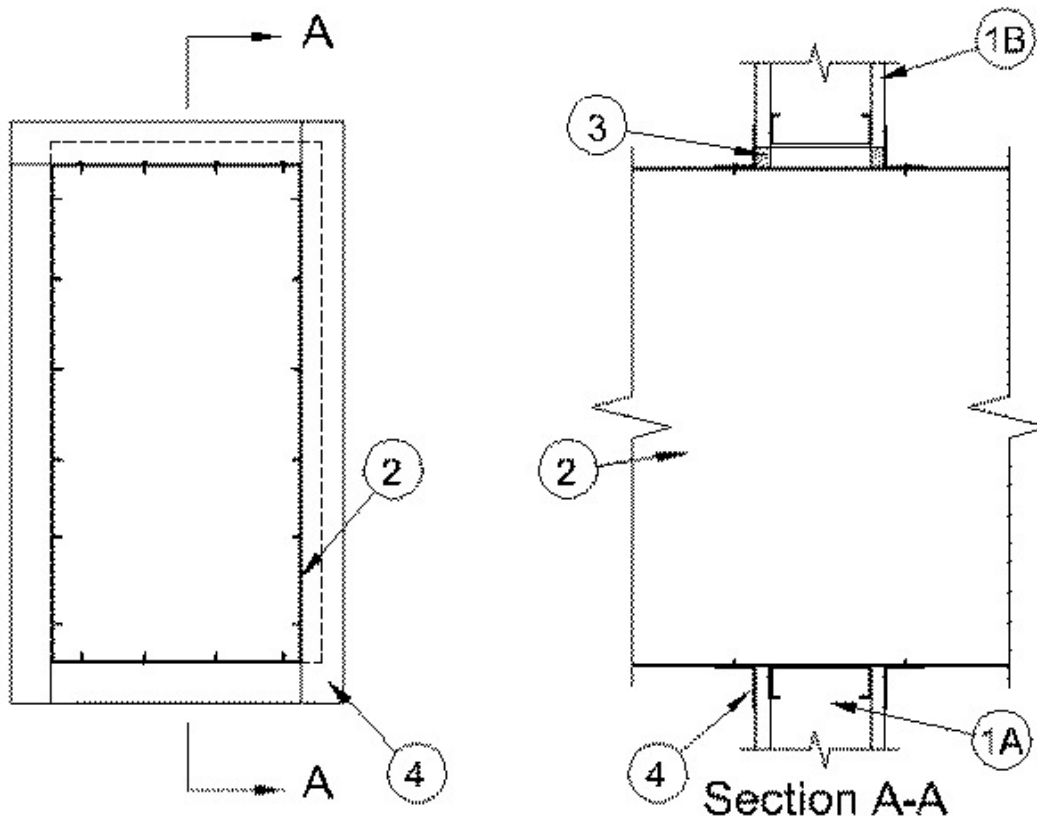

1. **Wall Assembly** — The 1 hr fire-rated gypsum board/stud wall assembly shall be constructed of the materials and in the manner specified in the individual U400 or V400 Series Wall and Partition Designs in the UL Fire Resistance Directory and shall include the following construction features:

A. **Studs** — Wall framing shall consist of min 3-5/8 in. (92 mm) wide steel studs, spaced max 24 in. (610 mm) OC. Additional min 3-5/8 in. (92 mm) wide steel studs shall be used to completely frame the opening.

B. **Gypsum Board*** — Min 5/8 in. (16 mm) thick, 4 ft (1.22 m) wide with square or tapered edges. The gypsum board type, thickness, number of layers and orientation shall be as specified in the individual design. Max size of opening is 325 in.2 (21.0 cm2) with a max dimension of opening 25 in. (635 mm).

2. **Steel Duct** — Max 12 by 24 in. (305 by 610 mm) by min 0.028 in. (0.71 mm) thick steel duct to be installed either concentrically or eccentrically within the opening. The annular space shall be min 0 in. (0 mm, point contact) to max 1 in. (25 mm). Duct to be rigidly supported on both sides of wall assembly.

3. **Fill, Void or Cavity Material* - Caulk** — Min 5/8 in. (16 mm) thickness of fill material applied within the annulus, flush with both surfaces of wall.

POLYMER ADHESIVES SEALANT SYSTEMS INC — FireSeal 814

4. **Steel Retaining Angles** — Min 2 by 2 by 0.030 in. (51 by 51 by 0.76 mm) steel angles attached to all four sides of duct on both sides of wall. The angles shall be attached to the duct with min 1/8 in. (3 mm) diam steel rivets or No. 8 (or larger) sheet metal screws spaced max 2 in. (51 mm) from each end of duct and spaced a max of 5 in. (127 mm) OC.

*Bearing the UL Classification Mark

Last Updated on 2005-06-29

[Questions?](#)

[Print this page](#)

[Terms of Use](#)

[Page Top](#)

© 2013 UL LLC

When the UL Leaf Mark is on the product, or when the word "Environment" is included in the UL Mark, please search the [UL Environment database](#) for additional information regarding this product's certification.

The appearance of a company's name or product in this database does not in itself assure that products so identified have been manufactured under UL's Follow-Up Service. Only those products bearing the UL Mark should be considered to be Certified and covered under UL's Follow-Up Service. Always look for the Mark on the product.

UL permits the reproduction of the material contained in the Online Certification Directory subject to the following conditions: 1. The Guide Information, Assemblies, Constructions, Designs, Systems, and/or Certifications (files) must be presented in their entirety and in a non-misleading manner, without any manipulation of the data (or drawings). 2. The statement "Reprinted from the Online Certifications Directory with permission from UL" must appear adjacent to the extracted material. In addition, the reprinted material must include a copyright notice in the following format: "© 2013 UL LLC".