

MEGABLUE®



3 YEAR WARRANTY

PERFORMANCE

21 dba

MAX FLOW	MAX HEAD	MAX LIFT
13.2 G/ HOUR	66.5 FEET	23 FEET

The MEGABLUE® has a slimline, lightweight design and is whisper quiet, it also has the performance to overcome installation challenges and uses the BlueDiamond® revolutionary patented principle, making it inherently reliable. With the MEGABLUE® there's no cost penalty up front but big savings on installation and in service beyond.



SENSING OPTION

MEGABLUE® pump available with:

RESERVOIR

X87-835

PERFORMANCE

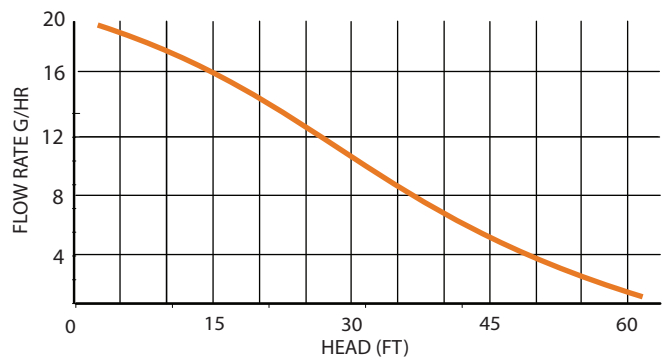

3 YEAR WARRANTY

Accredited with our own industry pioneering 3 year warranty. We have faith in our reliability and so should you.



BLUEDIAMOND® Pumps are the only manufacturer of patented Rotary Diaphragm (RD) and GyRok™ technology.

DIMENSIONS (")

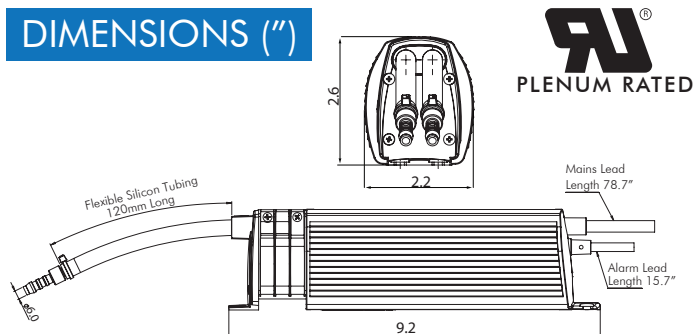

DISCHARGE PIPE RUN



V (VERTICAL)	H (HORIZONTAL)
65 FT	0 FT
50 FT	50 FT
32 FT	100 FT
16 FT	150 FT
0 FT	200 FT

The MEGABLUE® can be mounted in any orientation up to 23FT away from the air conditioning unit.